



US00D781963S

(12) **United States Design Patent** (10) **Patent No.:** **US D781,963 S**
Minter (45) **Date of Patent:** **** Mar. 21, 2017**

- (54) **CHILD’S EGG SHAPED RIDE-IN CAR**
- (71) Applicant: **Barbara Minter**, Los Angeles, CA (US)
- (72) Inventor: **Barbara Minter**, Los Angeles, CA (US)
- (**) Term: **15 Years**
- (21) Appl. No.: **29/554,640**
- (22) Filed: **Feb. 12, 2016**
- (51) **LOC (10) Cl.** **21-01**
- (52) **U.S. Cl.**
USPC **D21/427**
- (58) **Field of Classification Search**
USPC D21/419, 424–428, 533, 534, 560,
D21/831–833; D12/1, 16, 83, 129
CPC .. B62M 6/00; B62M 1/00; B62M 1/36; B62B
9/00; B62B 9/12
See application file for complete search history.

D252,692 S *	8/1979	Petrisco	D21/560
D254,743 S *	4/1980	Petrisco	D21/427
D256,482 S *	8/1980	Brown	D21/427
D276,172 S *	10/1984	Murakami	D21/560
D276,249 S *	11/1984	Murakami	D21/560
D276,357 S *	11/1984	Murakami	D21/560
D276,358 S *	11/1984	Murakami	D21/560
D347,037 S *	5/1994	Galloway	D21/427
D351,873 S *	10/1994	Jones, Jr.	D21/533
D366,634 S *	1/1996	Anderson	D12/102
D471,843 S *	3/2003	Hall	D12/16
D678,424 S *	3/2013	Blanco	D21/427
2007/0037480 A1	2/2007	Jarck		

* cited by examiner

Primary Examiner — Cynthia M Chin

(74) *Attorney, Agent, or Firm* — RG Patent Consulting, LLC; Rachel Gilboy

(57) **CLAIM**

The ornamental design for a child’s egg shaped ride-in car, as shown and described.

DESCRIPTION

FIG. 1 is a perspective view of the child’s egg shaped ride-in car with the car top half in an open position showing my new design;

FIG. 2 is a front elevation view thereof, with the car top half in a closed position;

FIG. 3 is a rear elevation view thereof;

FIG. 4 is a right elevation view thereof;

FIG. 5 is a left elevation view thereof;

FIG. 6 is a top plan view thereof; and,

FIG. 7 is a bottom plan view thereof.

1 Claim, 7 Drawing Sheets

(56) **References Cited**

U.S. PATENT DOCUMENTS

1,554,607 A	9/1925	Strauss	
D79,395 S *	9/1929	Sutherland D12/83
2,794,295 A	6/1957	Robertson	
D187,383 S *	3/1960	Dalton D21/427
3,252,711 A *	5/1966	Young A63B 19/02 280/78
D218,229 S *	8/1970	Ponthieu D12/85
D231,523 S *	4/1974	Baker D12/16
D231,911 S *	6/1974	Baker D12/1
D237,790 S *	11/1975	Cone D12/102

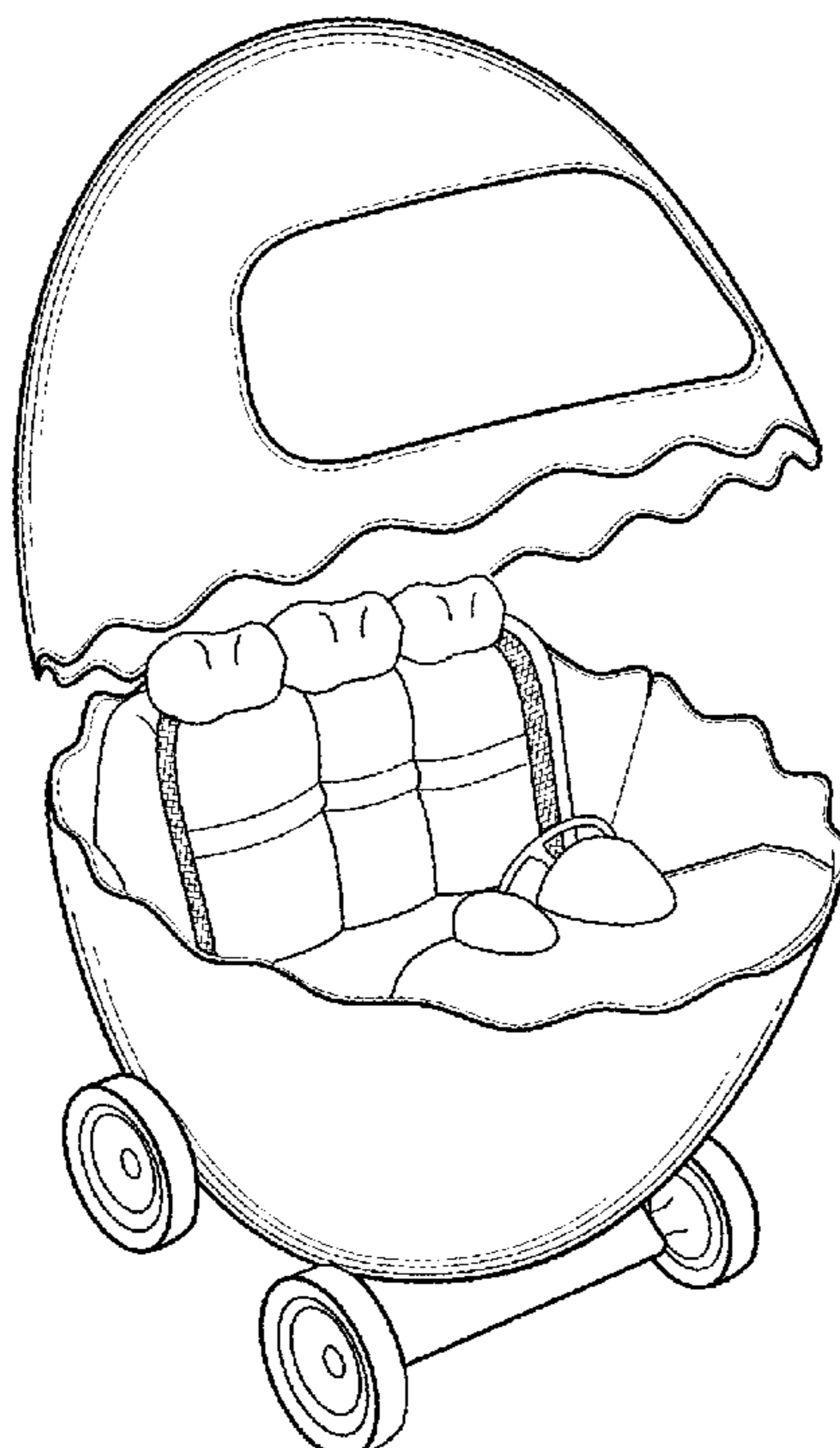

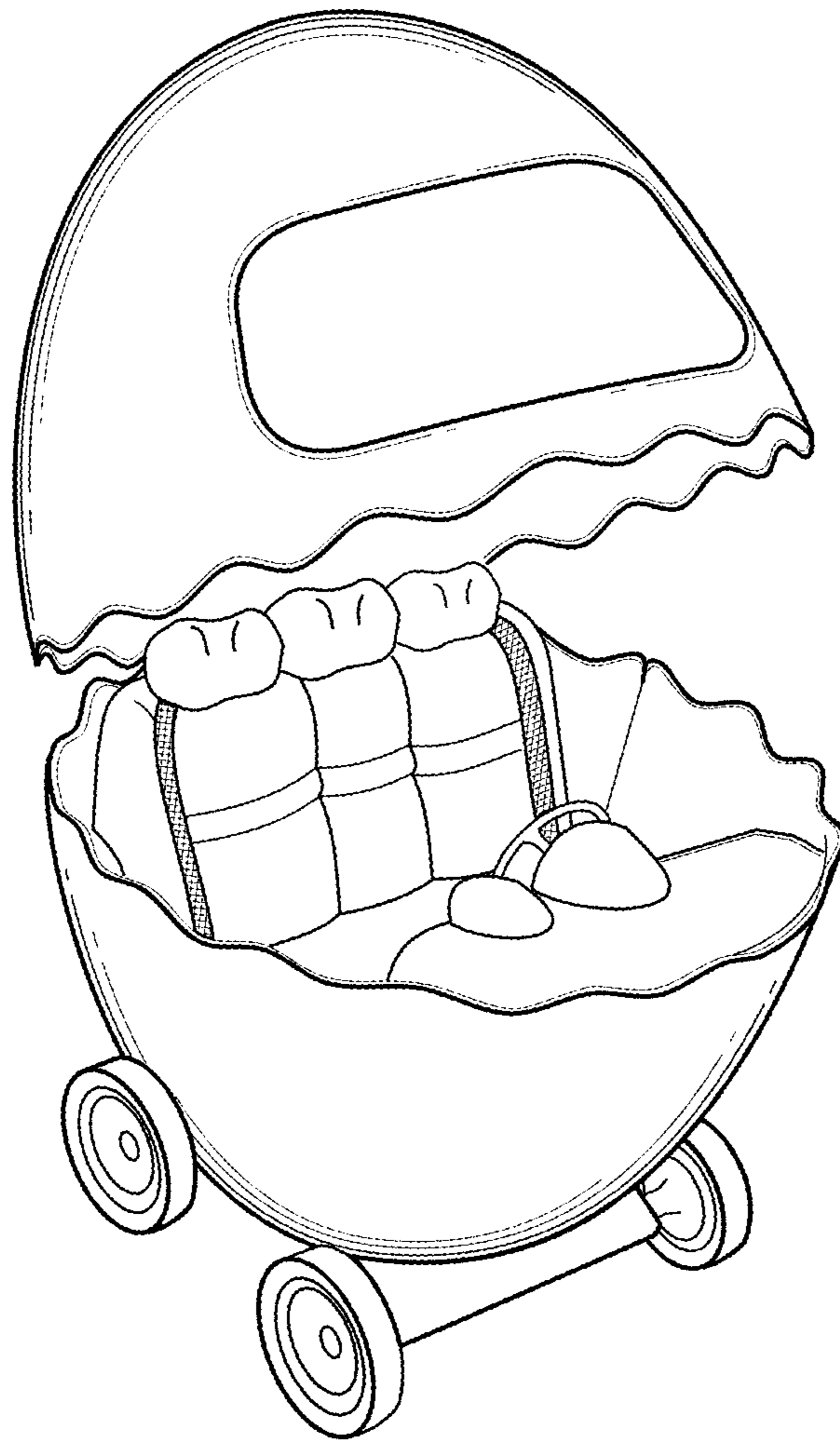

FIG. 1

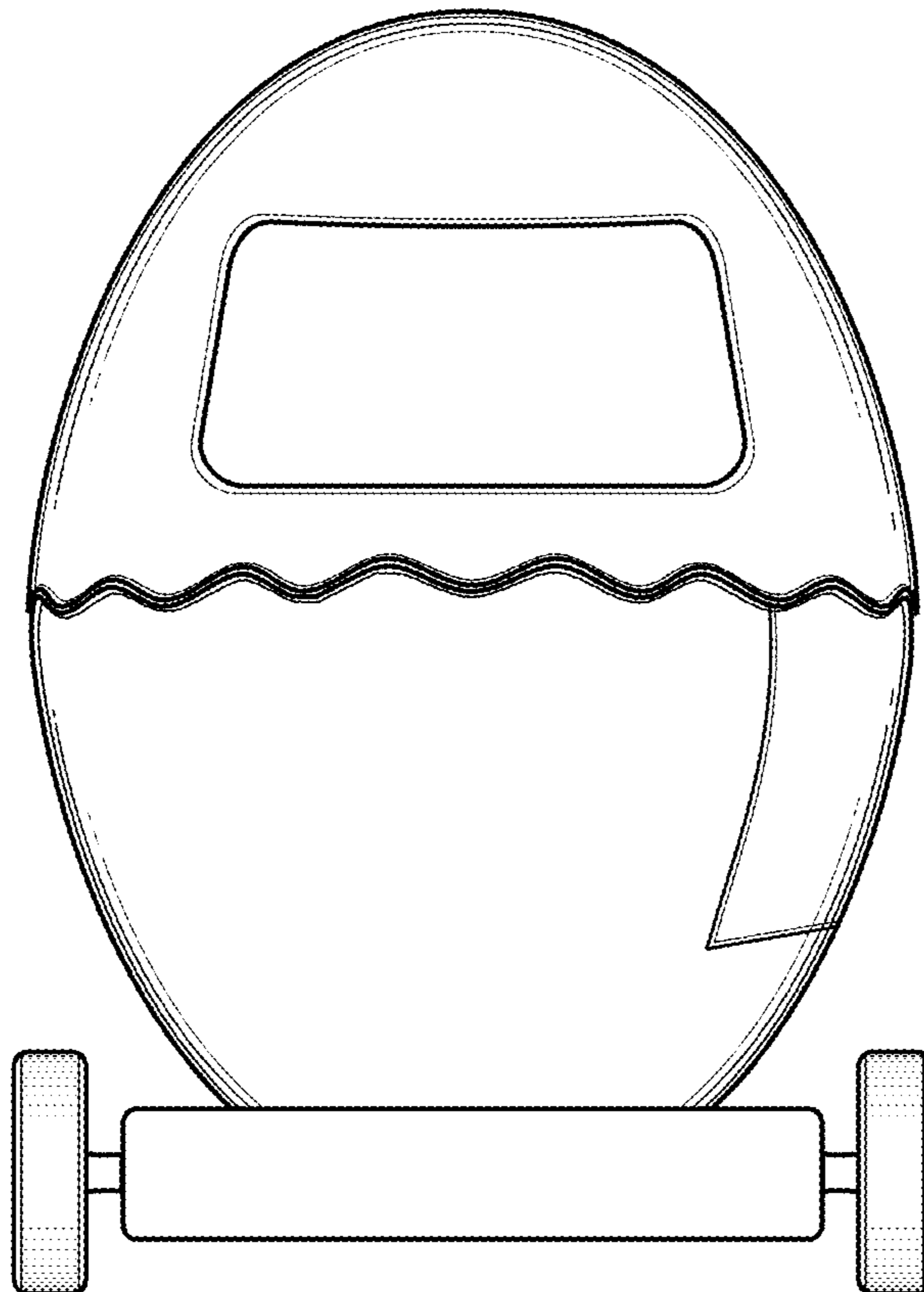

FIG. 2

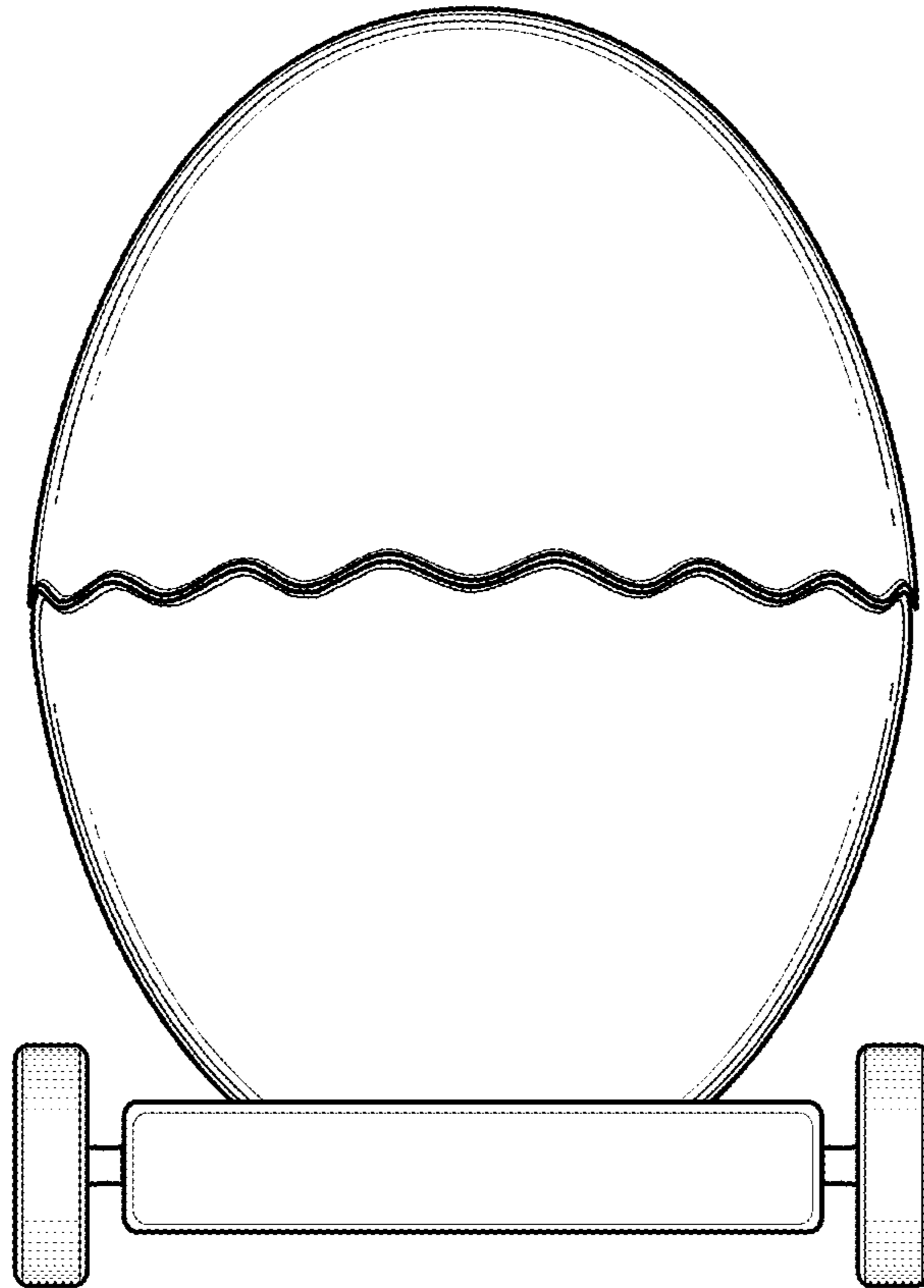

FIG. 3

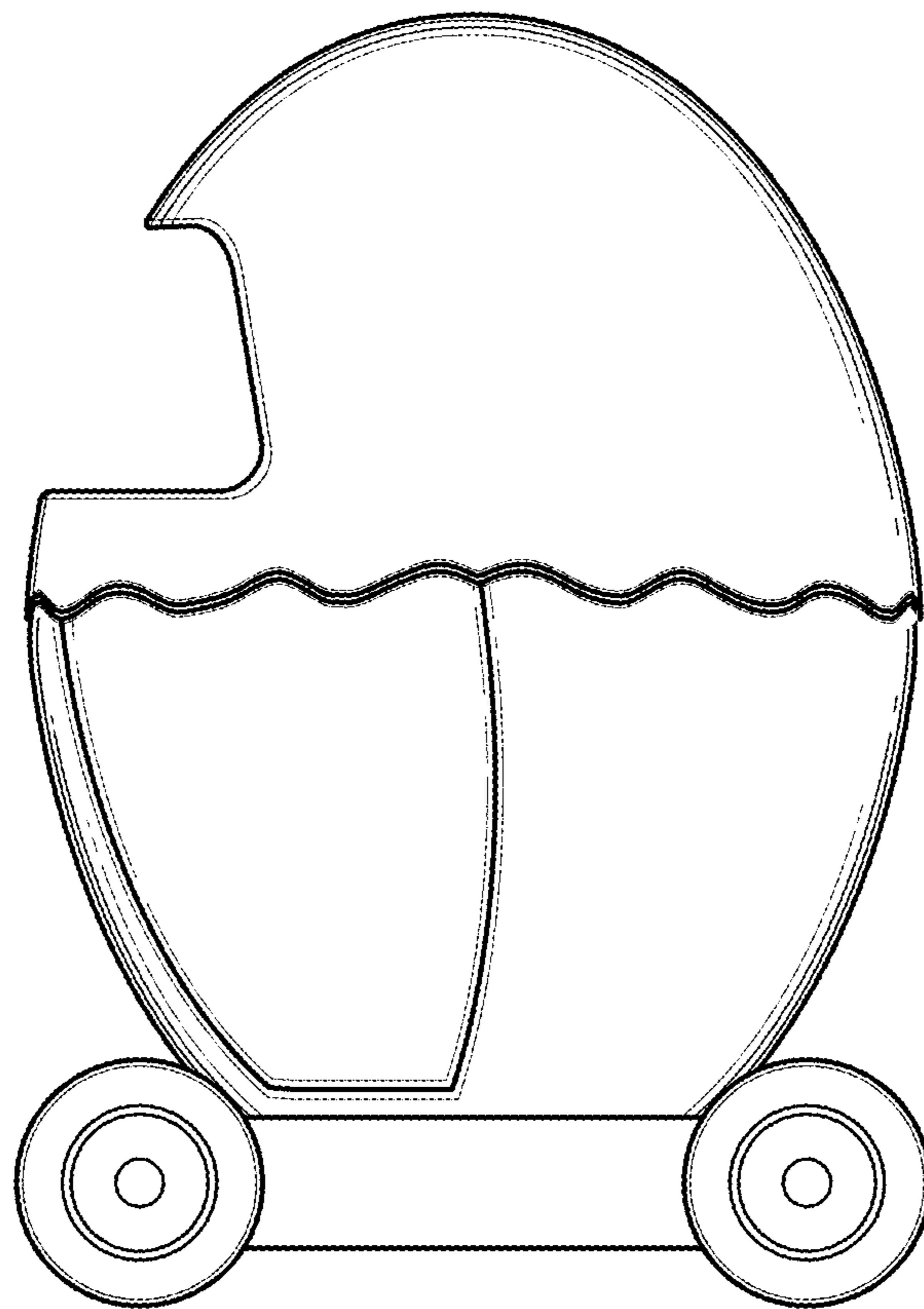

FIG. 4

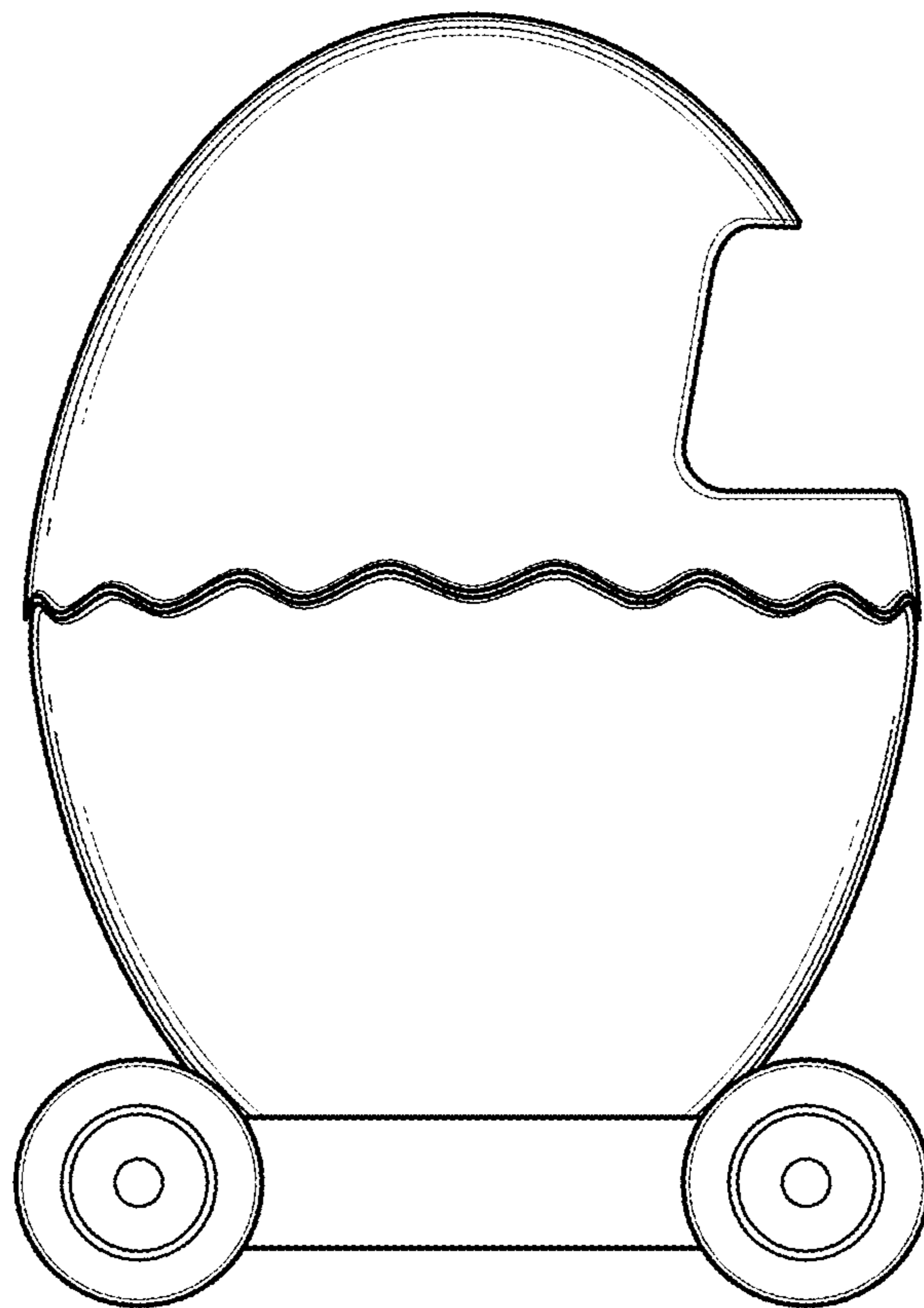

FIG. 5

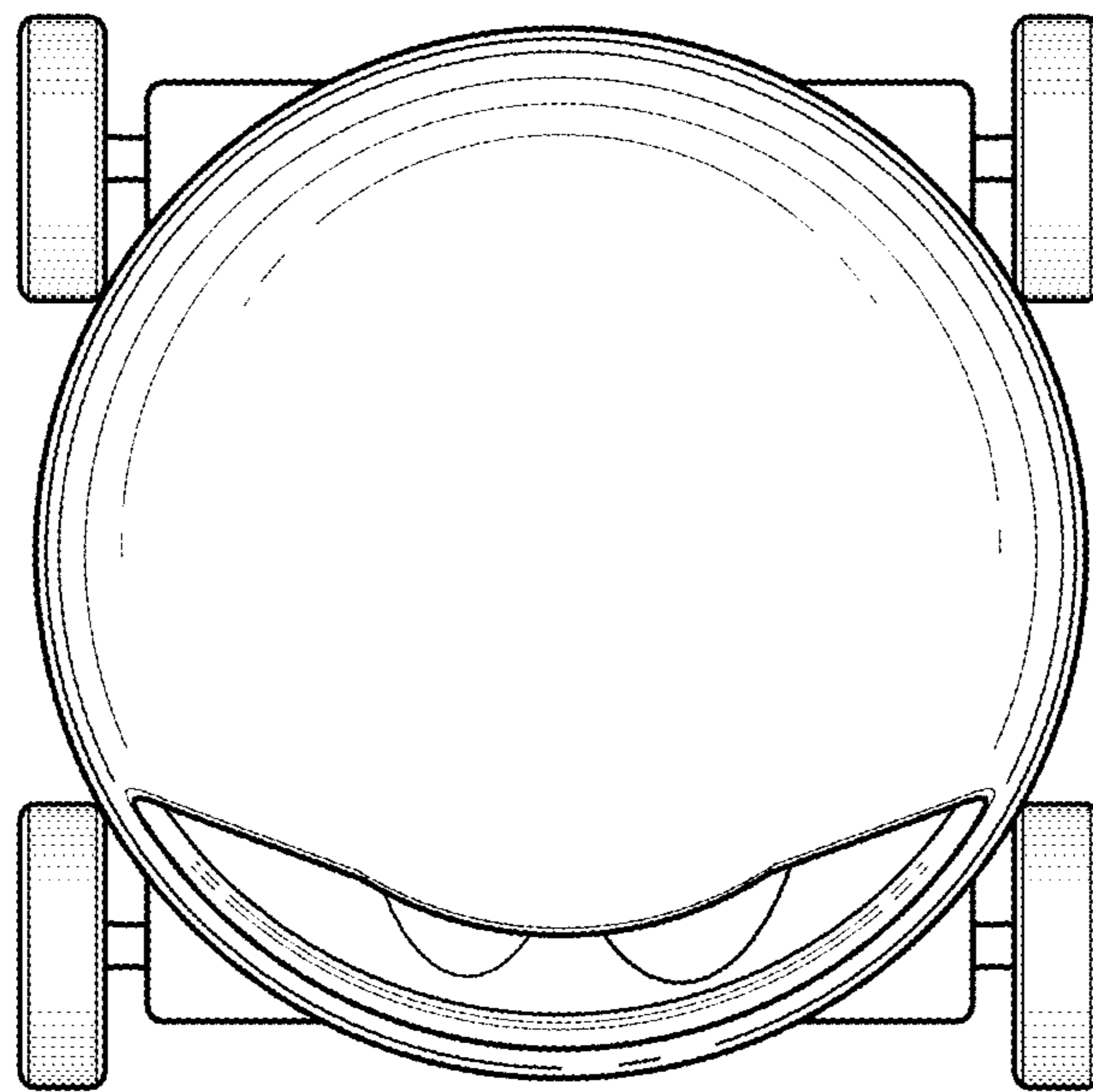

FIG. 6

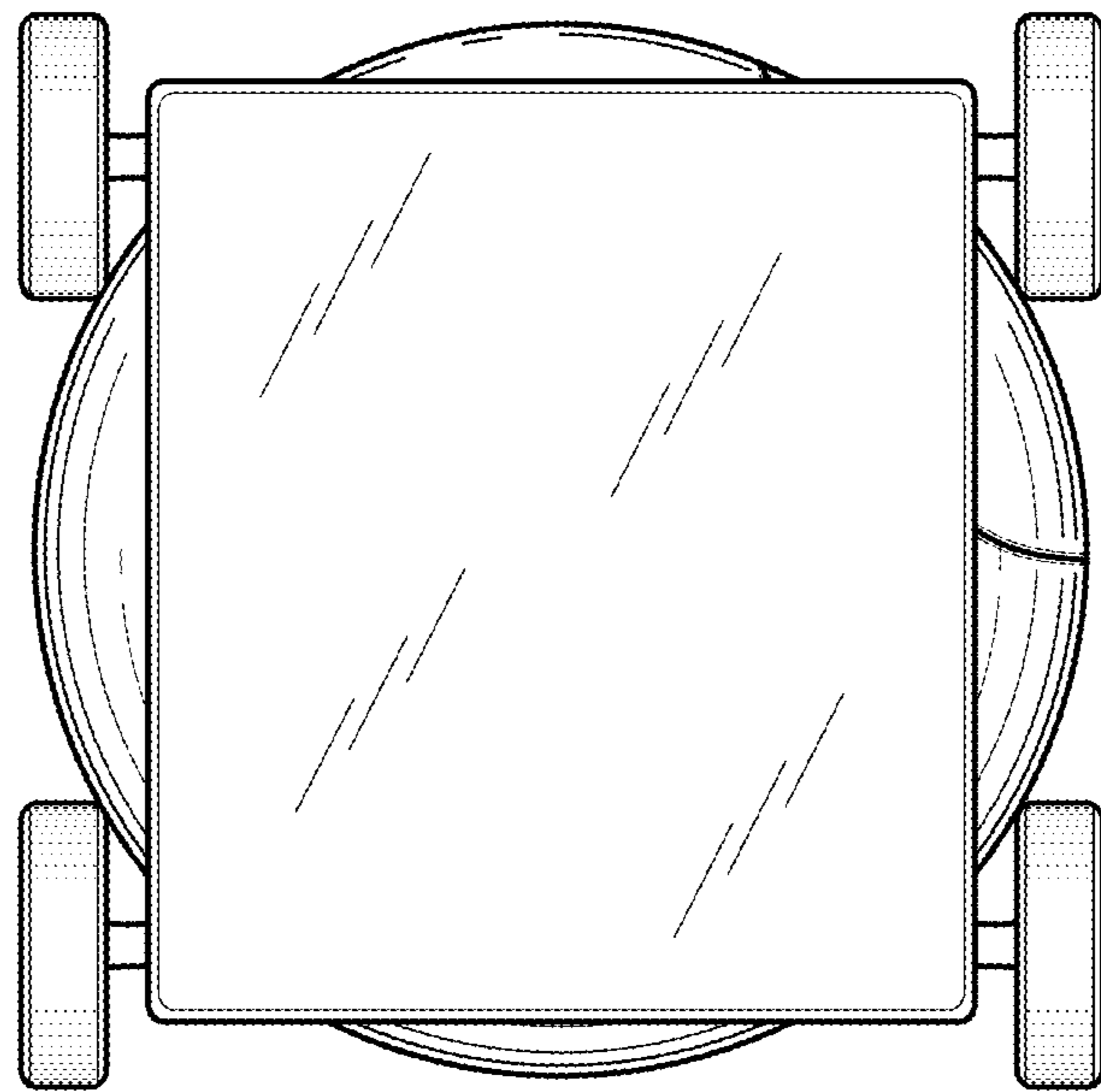

FIG. 7