



US00D781759S

(12) **United States Design Patent**
Galley et al.

(10) **Patent No.:** **US D781,759 S**

(45) **Date of Patent:** **** Mar. 21, 2017**

(54) **SPARE TIRE CARRIER**

(71) Applicant: **Intrinsic Minds, LLC**, Sedalia, CO
(US)

(72) Inventors: **Thomas Center Galley**, Sedalia, CO
(US); **Dexter N. Galley**, Morrison, CO
(US); **Derek T. Galley**, Louviers, CO
(US)

(73) Assignee: **Intrinsic Minds, LLC**, Sedalia, CO
(US)

(**) Term: **14 Years**

(21) Appl. No.: **29/510,209**

(22) Filed: **Nov. 25, 2014**

(51) **LOC (10) Cl.** **12-16**

(52) **U.S. Cl.**
USPC **D12/202**

(58) **Field of Classification Search**
USPC D12/202; 224/42.24, 521, 532, 519,
224/42.21; 362/500, 496, 540-541, 505
CPC B62D 43/02; B62D 43/06; B62D 43/00;
B60R 9/06; B60D 1/58; B60D 1/075
See application file for complete search history.

(56) **References Cited**

U.S. PATENT DOCUMENTS

D243,839 S *	3/1977	Driscoll	D12/202
D289,030 S *	3/1987	Bowman	D12/202
D345,337 S *	3/1994	Feller	D12/202
D355,632 S *	2/1995	Padgett	D12/202
D424,005 S *	5/2000	Henry	D12/202

D505,649 S *	5/2005	Kenney	D12/202
D562,206 S *	2/2008	Newbill	D12/202
D609,619 S *	2/2010	Newbill	D12/202
D730,794 S *	6/2015	Ridges	D12/202

* cited by examiner

Primary Examiner — Stacia Cadmus

(74) *Attorney, Agent, or Firm* — Holzer Patel Drennan

(57) **CLAIM**

We claim the ornamental design for a spare tire carrier, as shown and described.

DESCRIPTION

FIG. 1 is a front perspective view of a spare tire carrier according to our new design.

FIG. 2 is a rear perspective view thereof.

FIG. 3 is a right-side elevation view thereof. The left-side elevation view thereof is a mirror image of the right-side elevation view thereof.

FIG. 4 is a top plan view thereof.

FIG. 5 is a front elevation view thereof.

FIG. 6 is a rear elevation view thereof.

FIG. 7 is a bottom plan view thereof; and,

FIG. 8 is a reduced rear perspective view thereof, shown in a position of use attached to a utility task vehicle, a spare wheel, and a spare tire.

The stepped features of FIGS. 1-4 and 7 are shown in broken lines for illustrative purposes only and form no part of the claimed design.

The utility task vehicle, the spare wheel, and the spare tire of FIG. 8 are each shown in broken lines for illustrative purposes only and form no part of the claimed design.

1 Claim, 8 Drawing Sheets

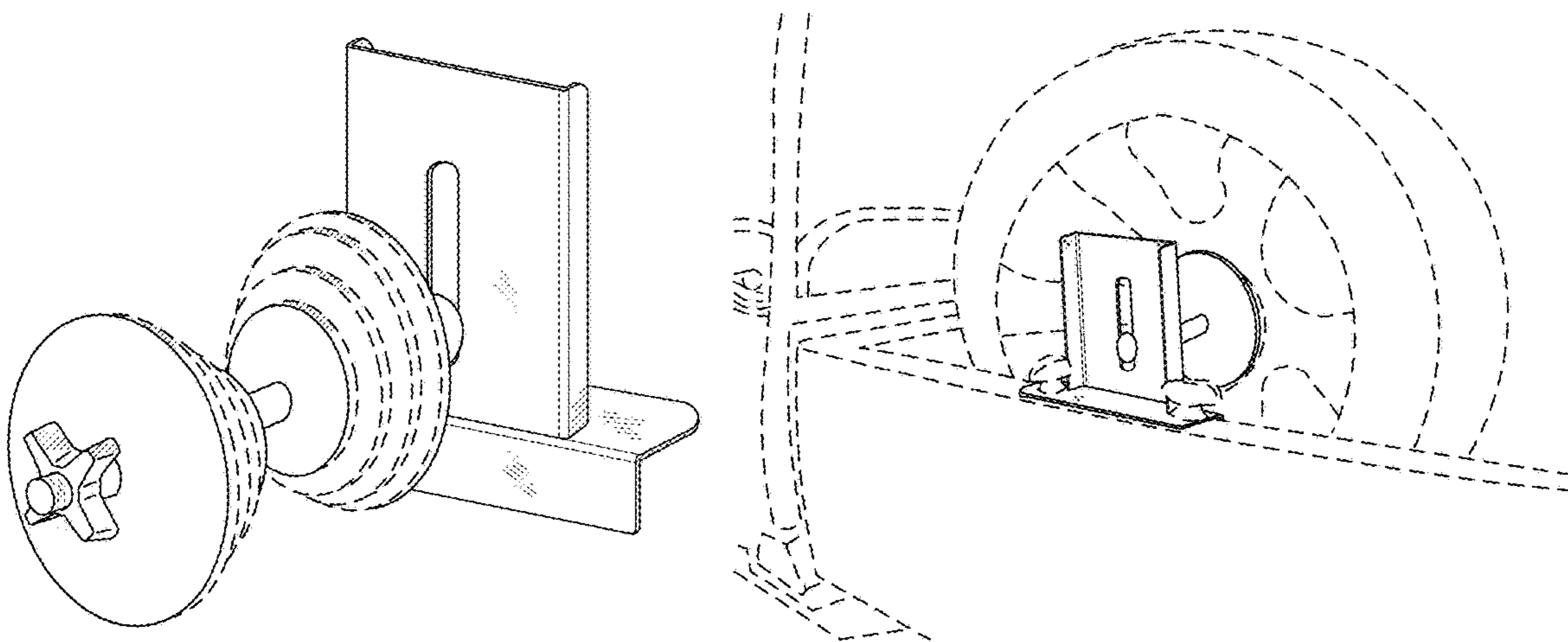

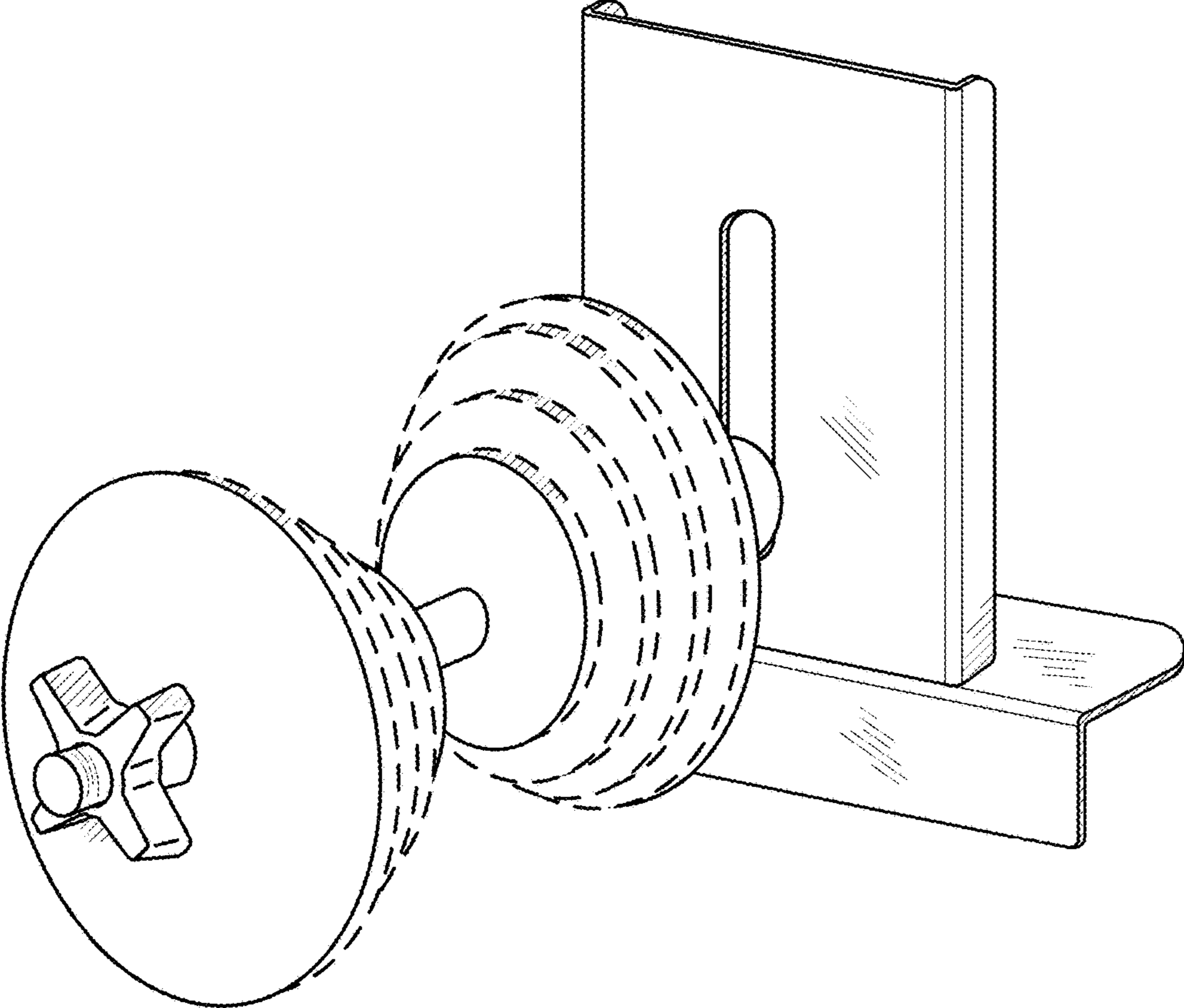

FIG. 1

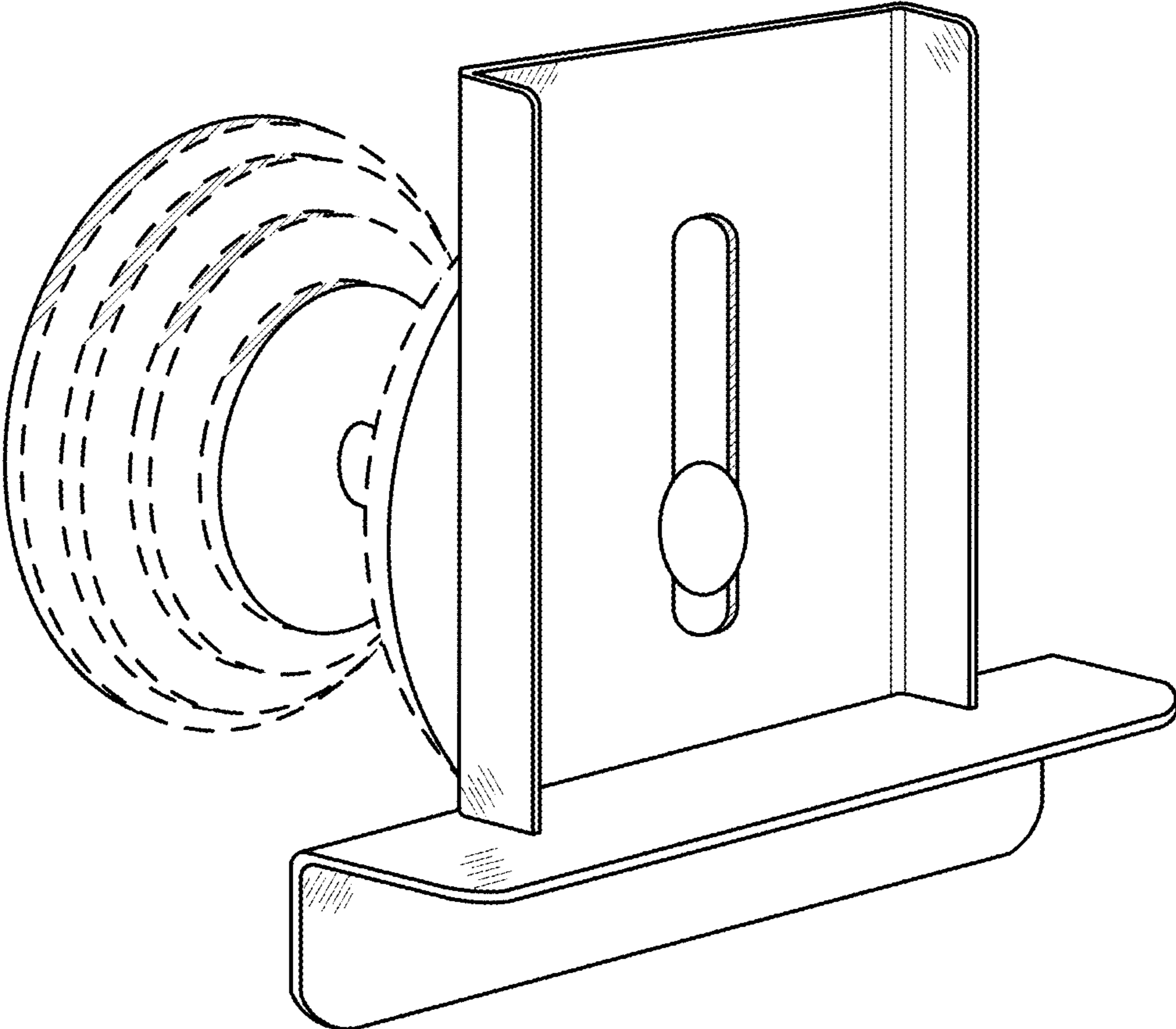

FIG. 2

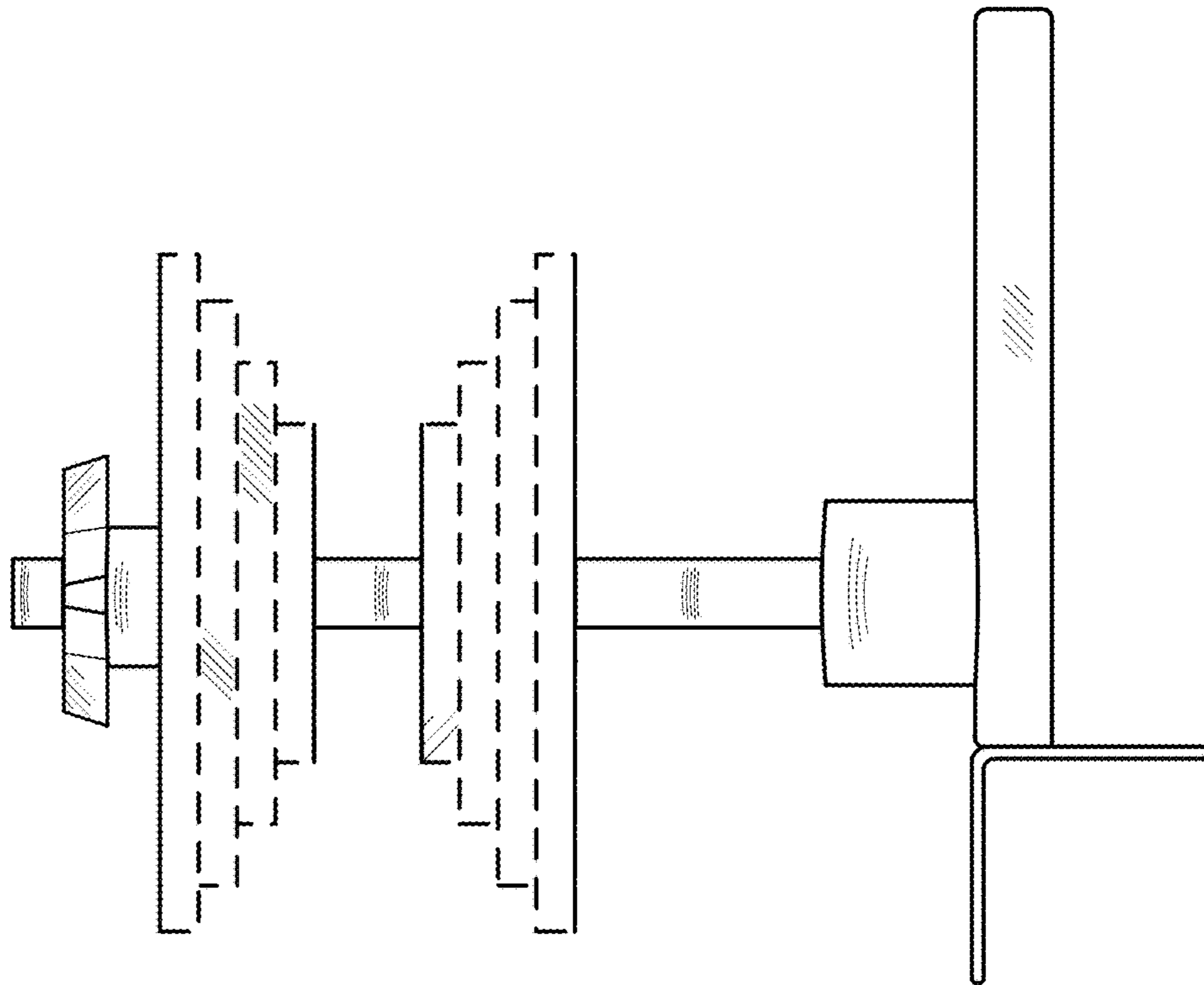

FIG. 3

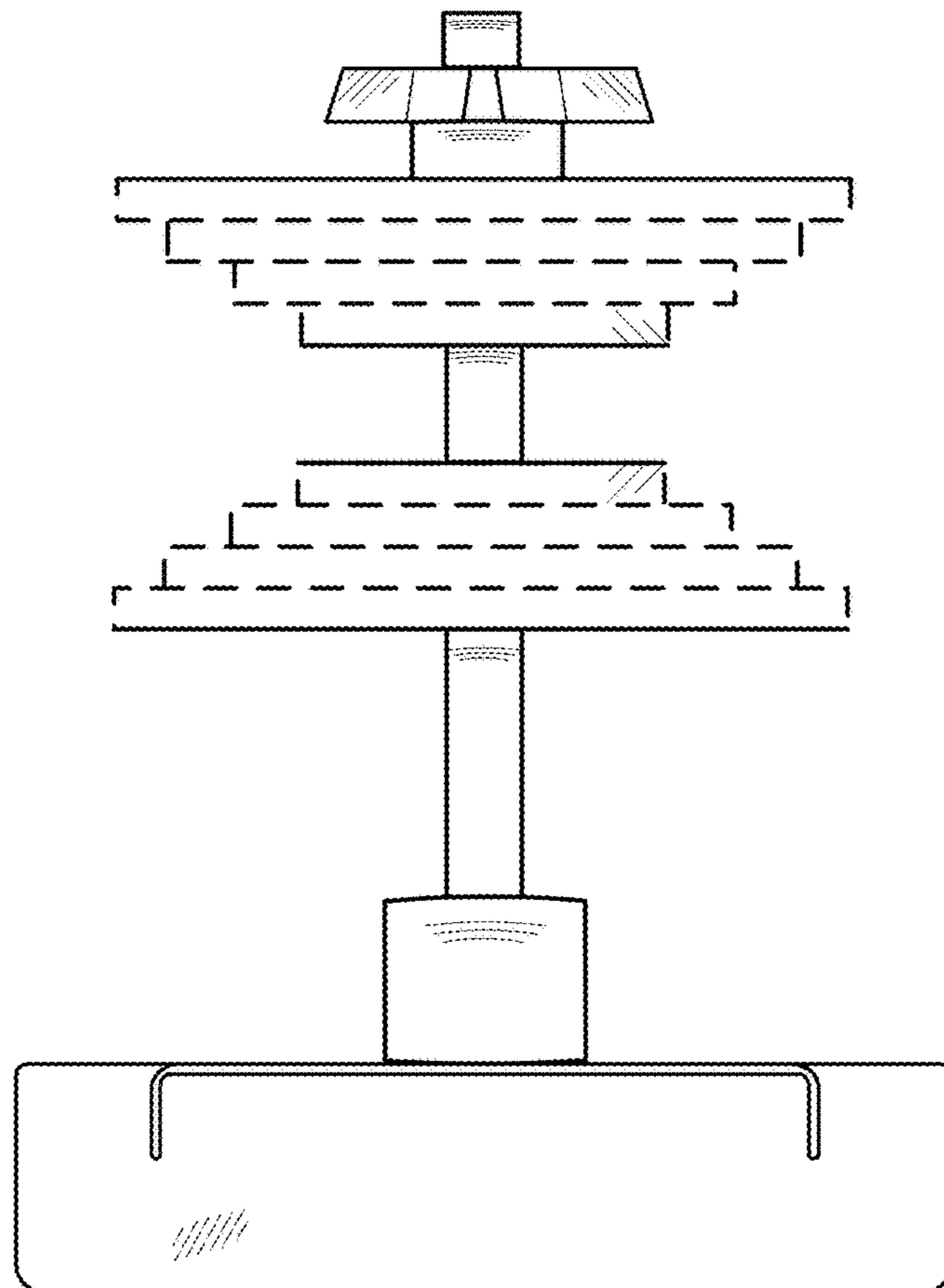

FIG. 4

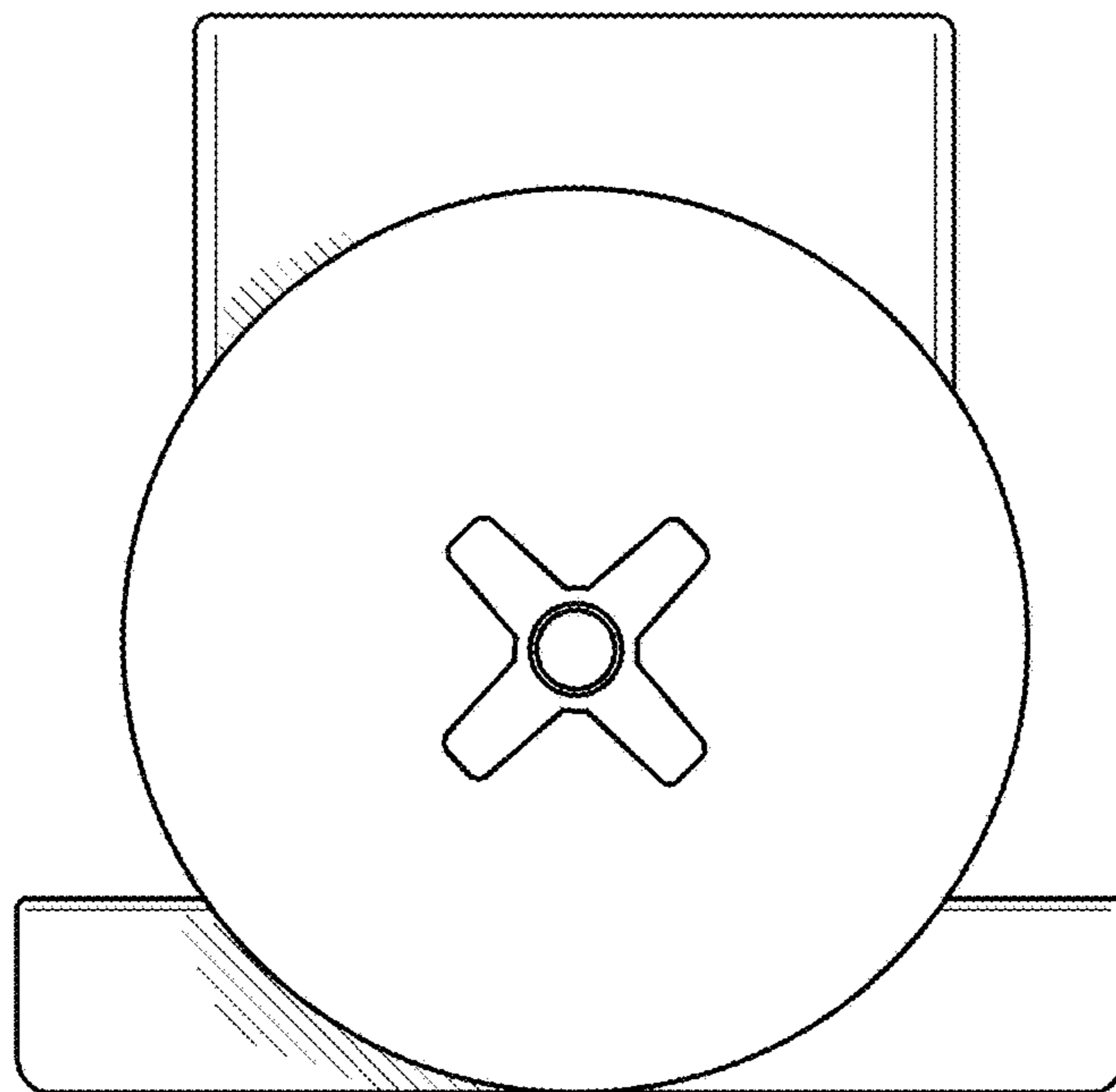

FIG. 5

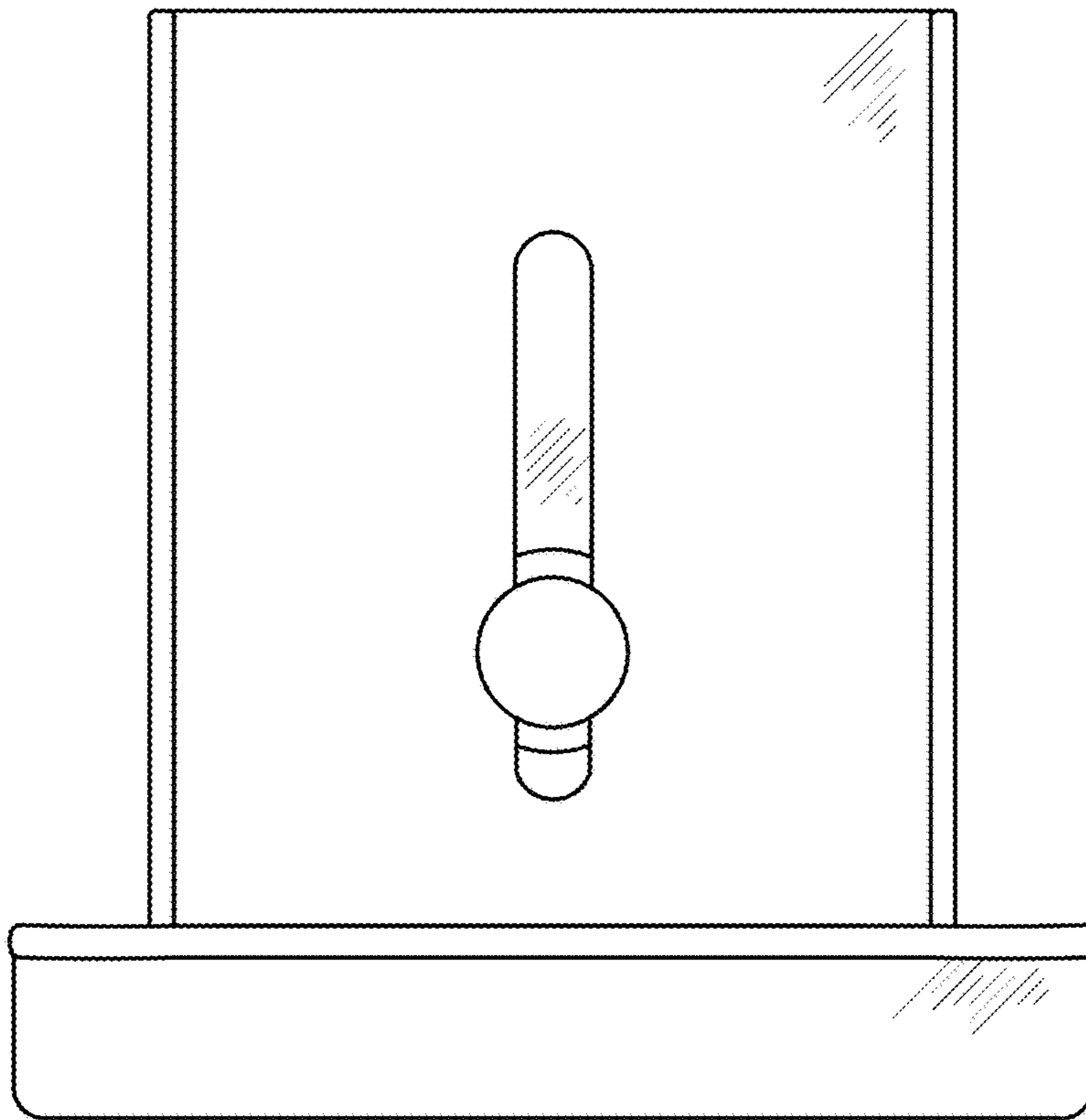

FIG. 6

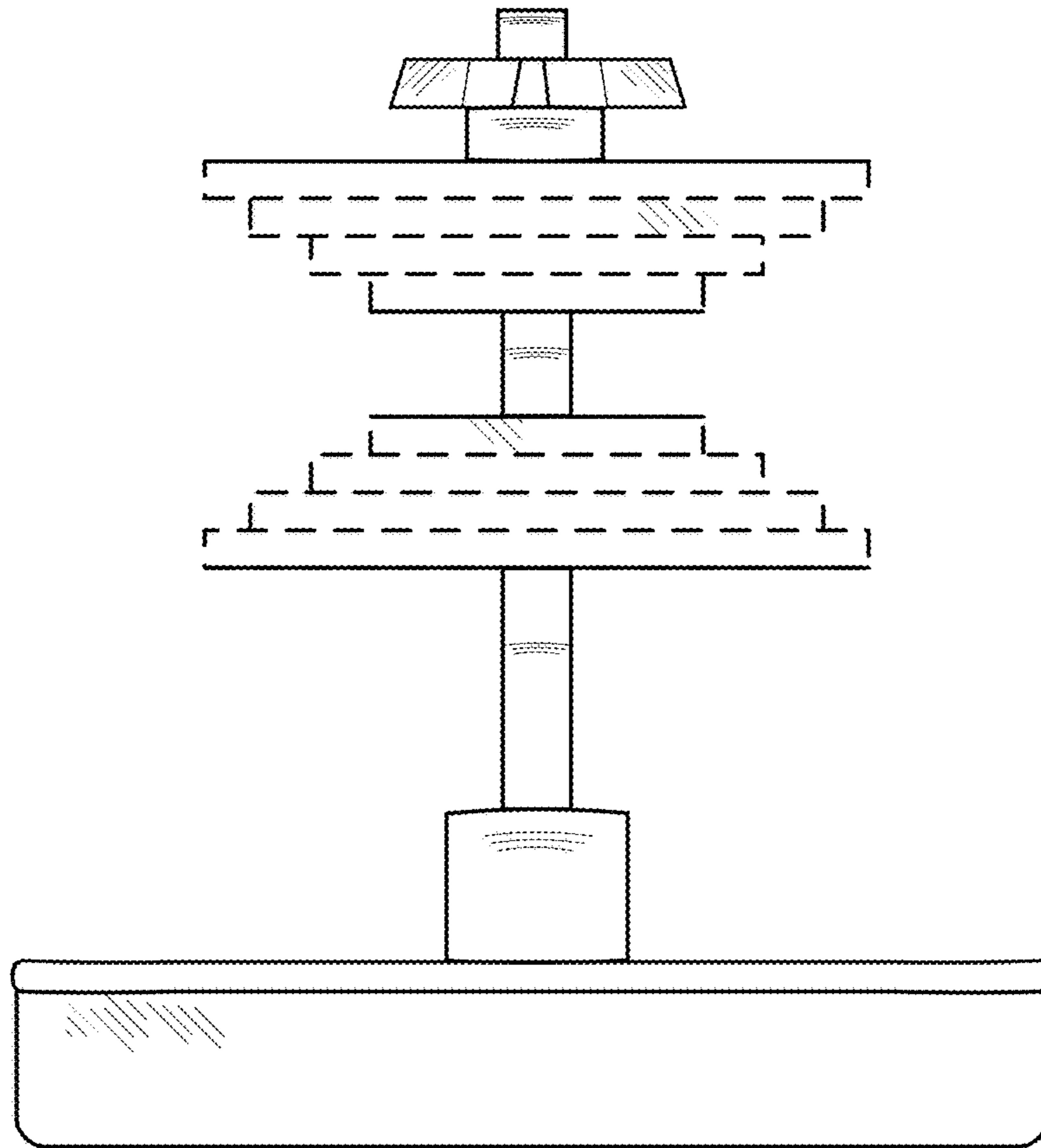

FIG. 7

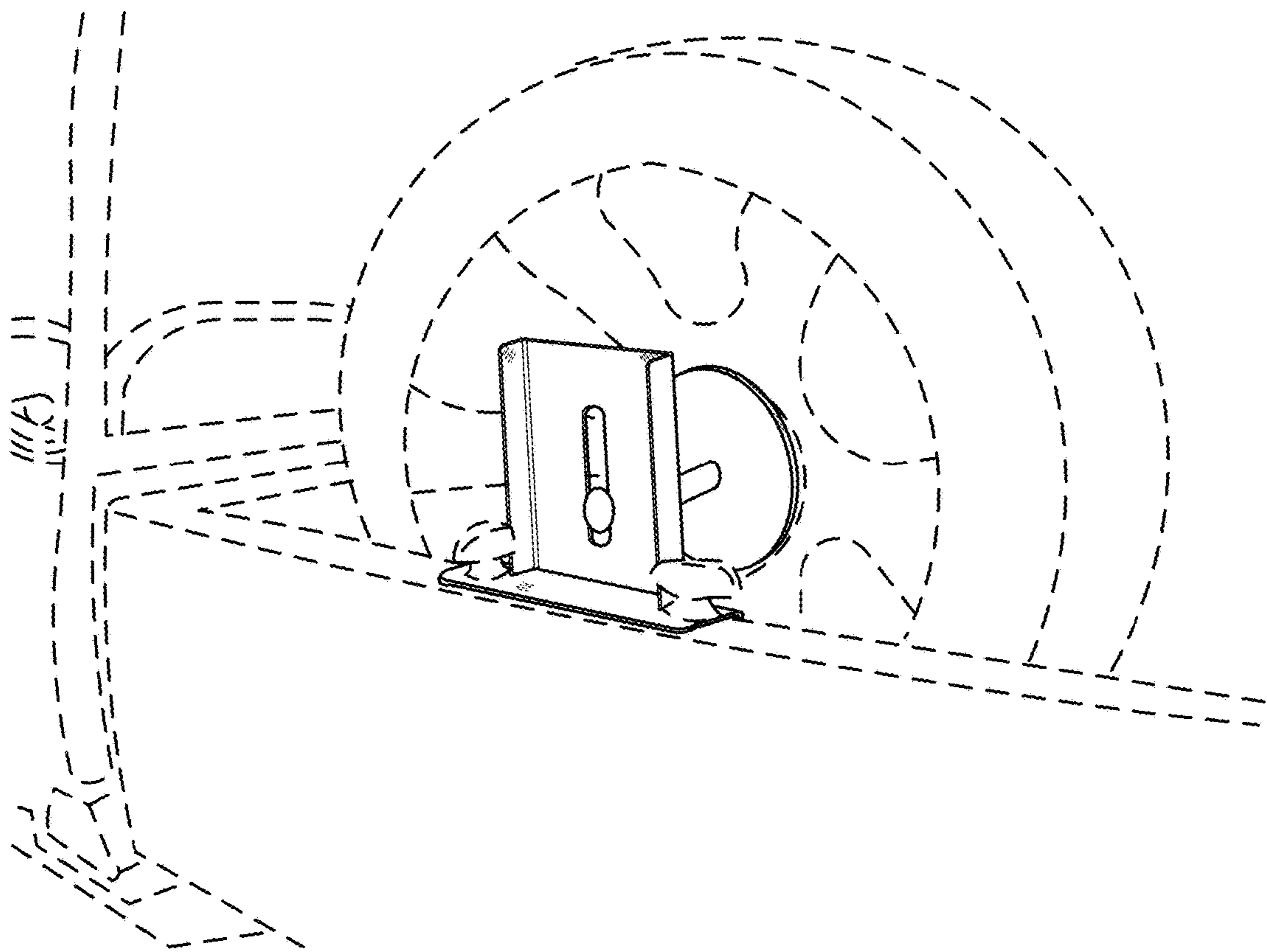

FIG. 8