



US00D781461S

(12) **United States Design Patent** (10) **Patent No.:** **US D781,461 S**
Thrush et al. (45) **Date of Patent:** **** Mar. 14, 2017**

(54) **BARRIER RAIL**

(56) **References Cited**

(71) Applicant: **Moddex Group Pty Ltd**, Boronia, Victoria (AU)

U.S. PATENT DOCUMENTS

(72) Inventors: **Stephen Thrush**, Maryborough (AU); **Dean Vos**, Mooroolbark (AU)

3,421,279 A * 1/1969 Franc B21D 13/045
428/599

(73) Assignee: **Moddex Group Pty Ltd.**, Victoria (AU)

3,466,831 A * 9/1969 Lenoir E04C 2/292
52/394

(**) Term: **14 Years**

D216,836 S * 3/1970 Faulkner D25/123

(21) Appl. No.: **29/509,248**

D395,089 S * 6/1998 Current D25/123

(22) Filed: **Nov. 14, 2014**

D403,085 S * 12/1998 Current D25/123

D698,944 S * 2/2014 Griffiths D25/119

D700,365 S * 2/2014 Griffiths D25/119

D718,883 S * 12/2014 Thrush D25/124

D718,884 S * 12/2014 Thrush D25/125

D734,501 S * 7/2015 Bodwell D25/119

D734,502 S * 7/2015 Bodwell D25/119

D736,962 S * 8/2015 Bodwell D25/119

(Continued)

Related U.S. Application Data

Primary Examiner — Cynthia Ramirez

(63) Continuation-in-part of application No. 29/447,928, filed on Mar. 7, 2013, now Pat. No. Des. 718,884.

Assistant Examiner — Llorellys Martinez-Rivera

(74) *Attorney, Agent, or Firm* — I. Morley Drucker; Fulwider Patton LLP

Foreign Application Priority Data

Oct. 2, 2014 (AU) 201415059

(57) **CLAIM**

The ornamental design for a barrier rail, as shown and described.

(51) **LOC (10) Cl.** **25-01**

DESCRIPTION

(52) **U.S. Cl.**
USPC **D25/121**

(58) **Field of Classification Search**
USPC D25/38.1, 39, 40, 41.1, 43, 44, 55, 102, D25/117, 119–124, 126, 133, 136, 138, D25/141, 148, 164; D20/42, 43, 44; D8/395, 396; D34/35; 52/86, 88, 272, 52/273, 285.3, 287.1
CPC E06B 3/5454; E06B 3/66366; E06B 3/667; E06B 2003/66395; E06B 2003/6258; E04B 2/03

FIG. 1 is a top and front perspective view of the barrier rail, showing our new design;

FIG. 2 is a right side elevation view thereof; the left side elevation view being a mirror image thereof;

FIG. 3 is an end view thereof;

FIG. 4 is a rear perspective view thereof; and,

FIG. 5 is a top plan view thereof.

The barrier rail is shown with a symbolic break in its length. The appearance of any portion of the barrier rail between the break lines forms no part of the claimed design.

See application file for complete search history.

1 Claim, 3 Drawing Sheets

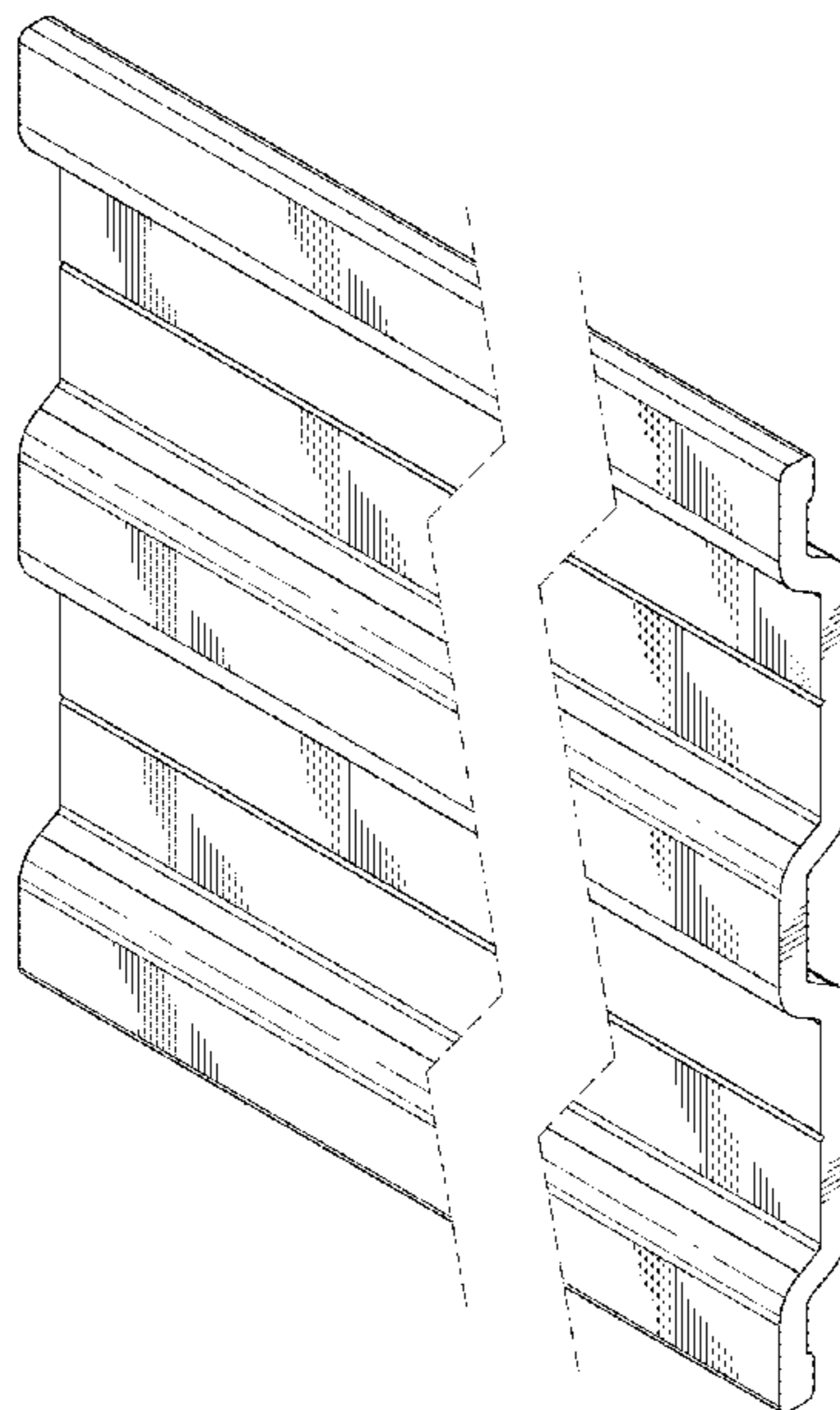

(56)

References Cited

U.S. PATENT DOCUMENTS

D746,669 S * 1/2016 McBride D25/121

* cited by examiner

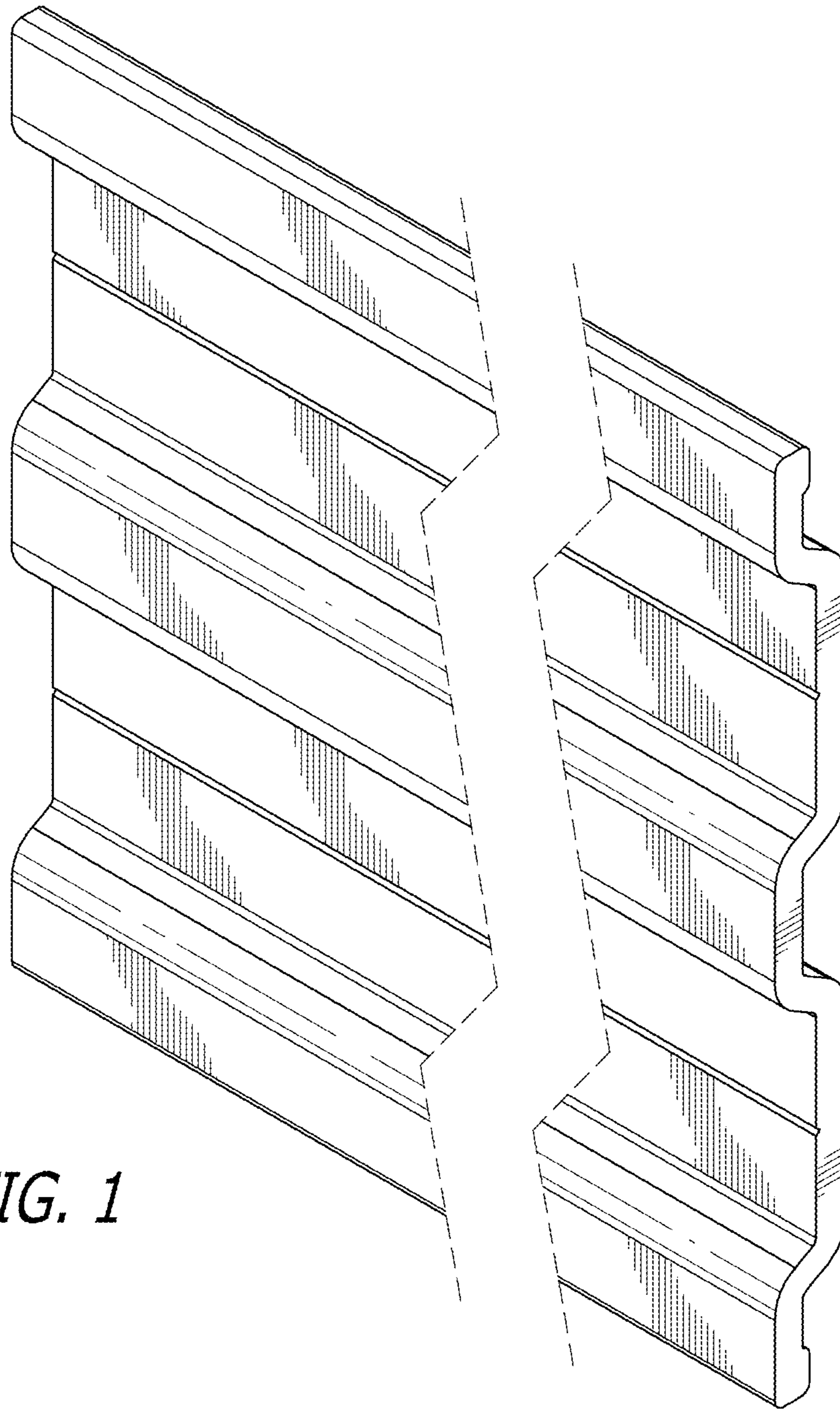

FIG. 1

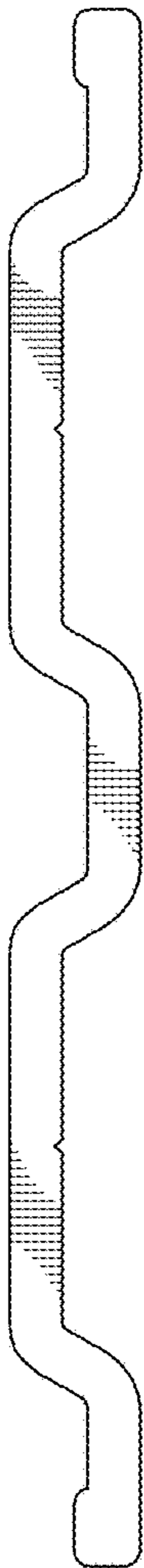

FIG. 3

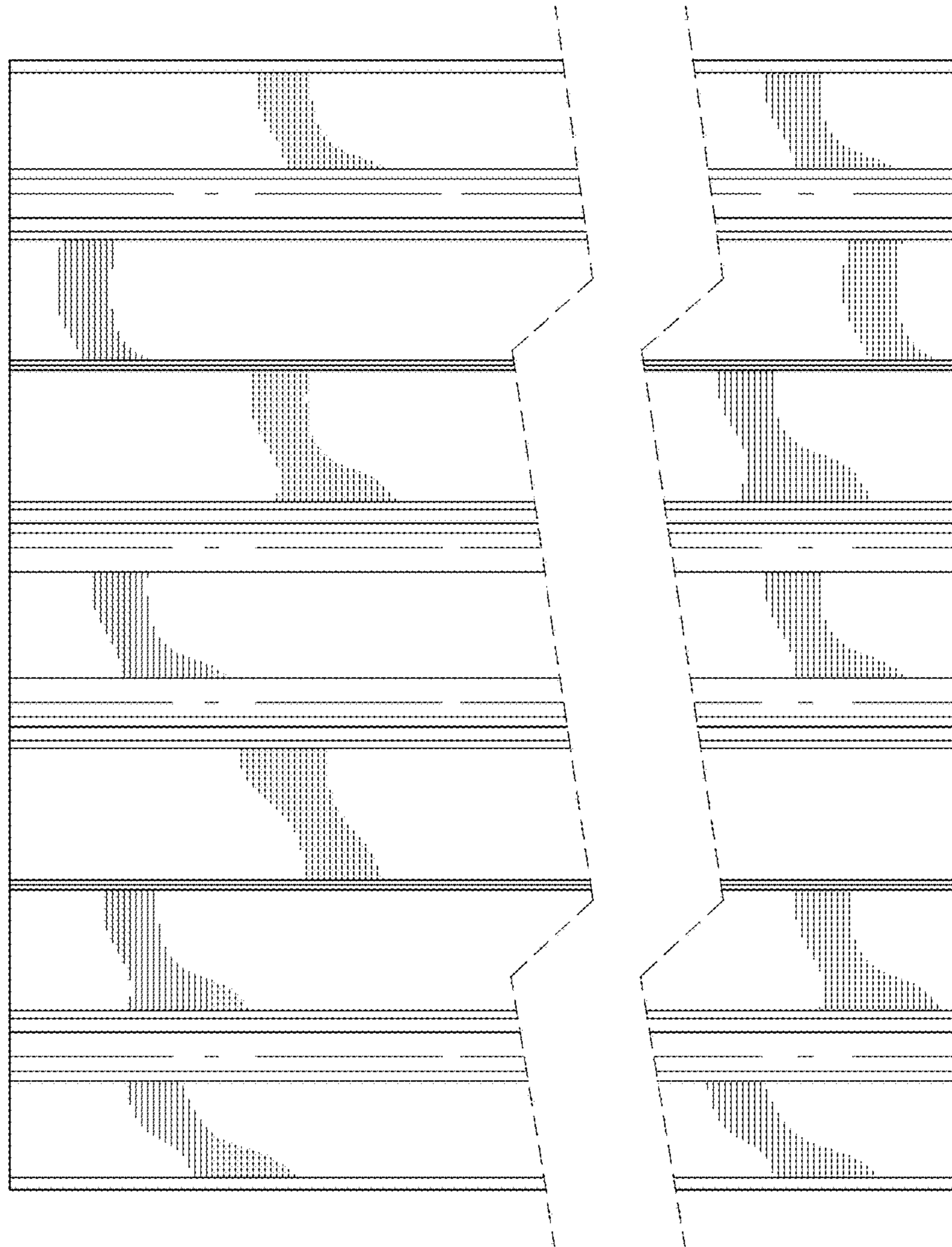

FIG. 2

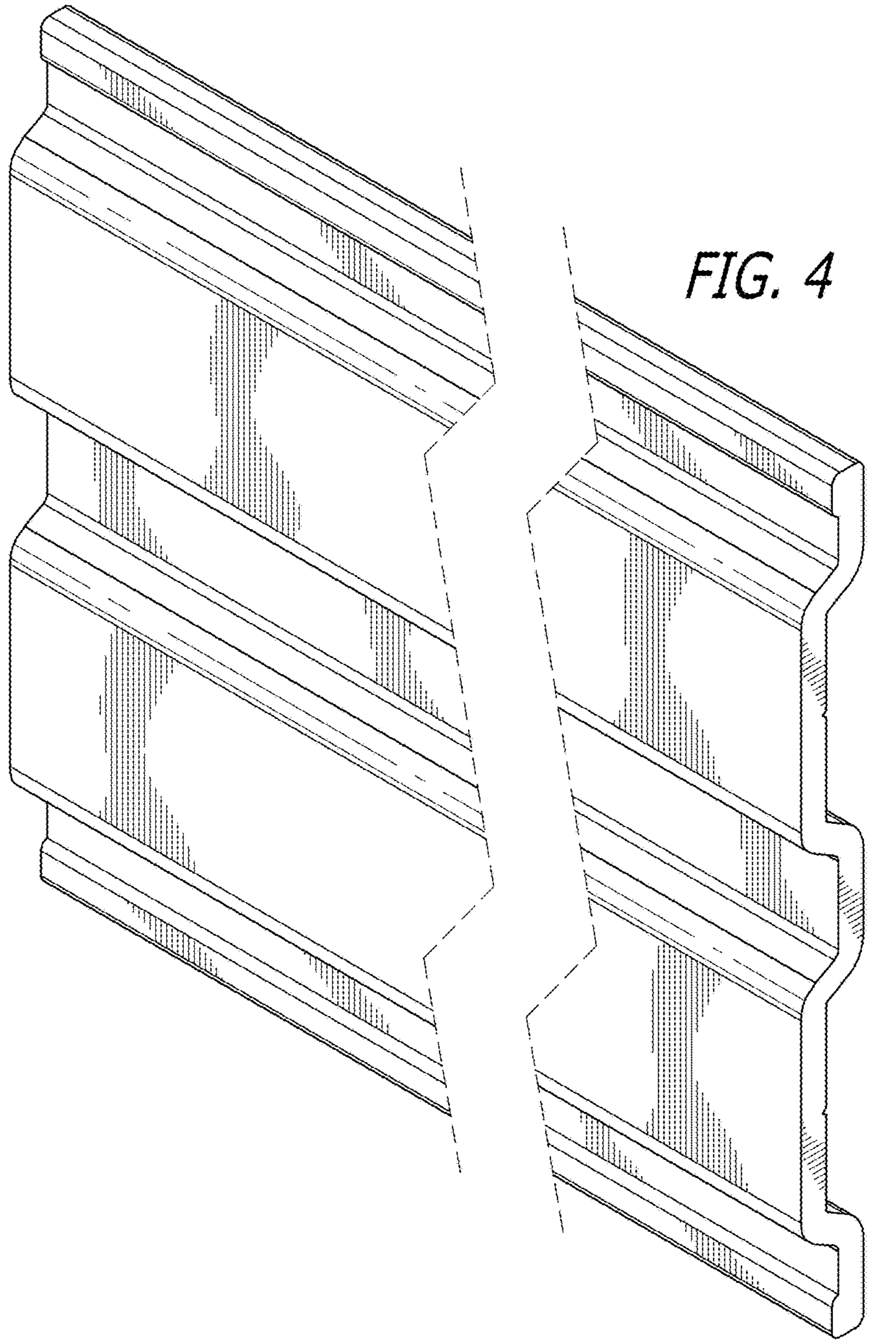

FIG. 4

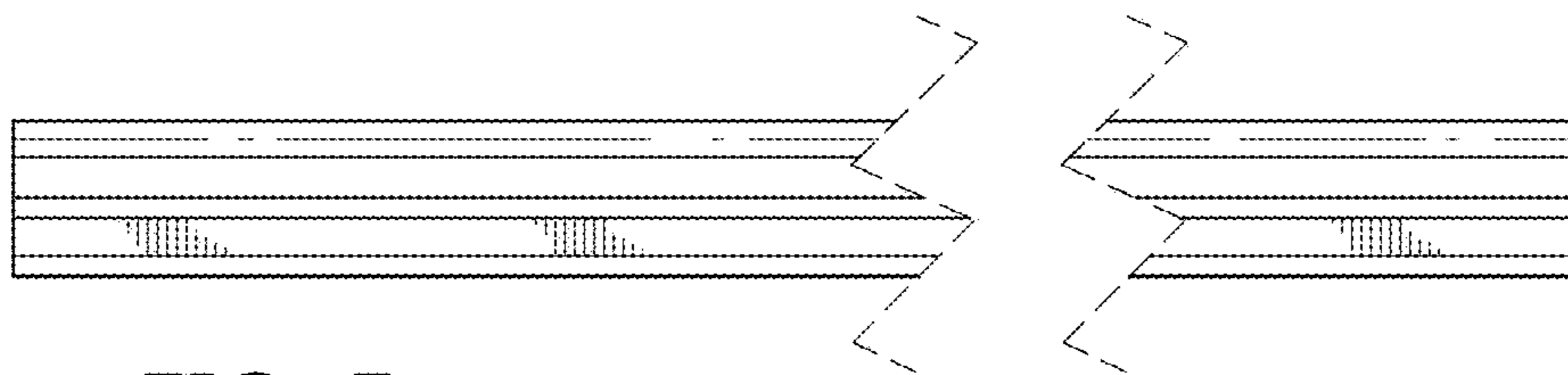

FIG. 5