



US00D781201S

(12) **United States Design Patent**
Ninov et al.

(10) **Patent No.:** **US D781,201 S**

(45) **Date of Patent:** **** Mar. 14, 2017**

(54) **AUTOMOBILE WHEEL**

(71) Applicants: **Deyan Ninov**, Royal Oak, MI (US);
Vincent J Galante, Lake Orion, MI (US); **Mark T Allen**, Oxford, MI (US)

(72) Inventors: **Deyan Ninov**, Royal Oak, MI (US);
Vincent J Galante, Lake Orion, MI (US); **Mark T Allen**, Oxford, MI (US)

(73) Assignee: **FCA US LLC**, Auburn Hills, MI (US)

(**) Term: **15 Years**

(21) Appl. No.: **29/561,185**

(22) Filed: **Apr. 14, 2016**

(51) **LOC (10) Cl.** **12-16**

(52) **U.S. Cl.**
USPC **D12/209**

(58) **Field of Classification Search**
USPC D12/204–213
CPC B60B 7/00; B60B 7/02; B60B 7/04; B60B 7/01; B60B 7/06; B60B 3/02; B60B 3/04; B60B 3/06; B60B 3/10; B60B 1/00; B60B 1/08; B60B 1/10; B60B 1/12
See application file for complete search history.

(56) **References Cited**

U.S. PATENT DOCUMENTS

D403,289 S *	12/1998	Watanabe	D12/209
D491,873 S *	6/2004	Markefka	D12/211
D512,007 S *	11/2005	Sze	D12/209
D534,850 S *	1/2007	Tsutamori	D12/209
D560,585 S *	1/2008	Blasi	D12/209

D586,280 S *	2/2009	Blasi	D12/209
D593,018 S *	5/2009	Juergens	D12/209
D593,920 S *	6/2009	Juergens	D12/209
D617,710 S *	6/2010	Ectors	D12/209
D617,712 S *	6/2010	Juergens	D12/209
D643,356 S *	8/2011	Gotschke	D12/209
D644,587 S *	9/2011	Gotschke	D12/209
D681,533 S *	5/2013	Campbell	D12/209
D683,684 S *	6/2013	Campbell	D12/209
D687,756 S *	8/2013	Campbell	D12/209
D715,718 S *	10/2014	Gotschke	D12/209
D737,748 S *	9/2015	Henstridge	D12/209
D754,582 S *	4/2016	Kobayashi	D12/209
D757,624 S *	5/2016	Hammoud	D12/209
D761,181 S *	7/2016	Bucher	D12/209
D763,760 S *	8/2016	Gale	D12/209
D763,764 S *	8/2016	Dunford	D12/209
D765,002 S *	8/2016	Hoste	D12/209

* cited by examiner

Primary Examiner — Stacia Cadmus

(74) *Attorney, Agent, or Firm* — Ralph E Smith

(57) **CLAIM**

The ornamental design for an automobile wheel, as shown and described.

DESCRIPTION

FIG. 1 is a front view of an automobile wheel showing our new design;

FIG. 2 is a right perspective view thereof; and,

FIG. 3 is a left perspective view.

It will be understood that the broken lines shown in the drawings illustrate portions of the automobile wheel that form no part of claimed design.

1 Claim, 3 Drawing Sheets

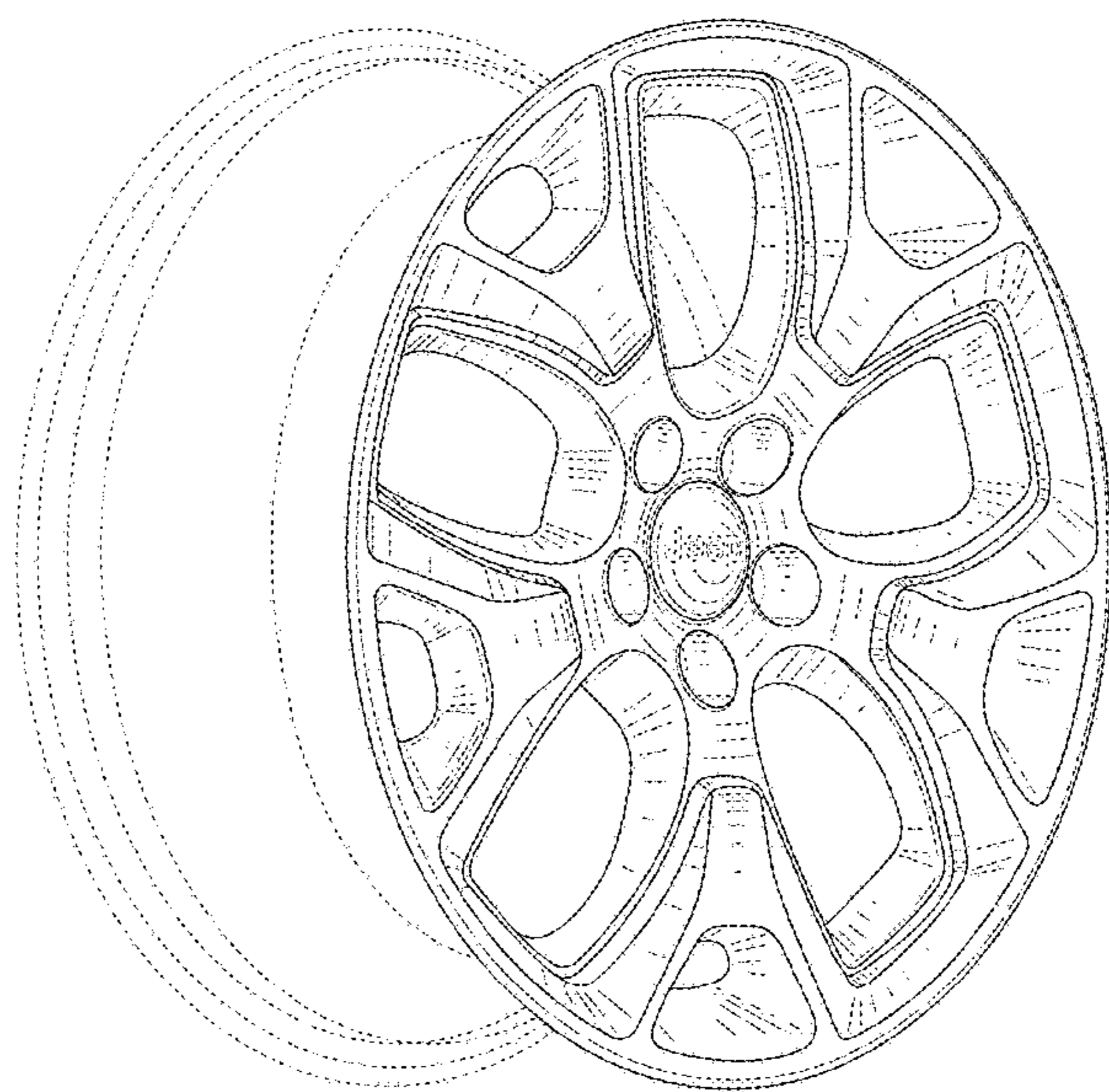
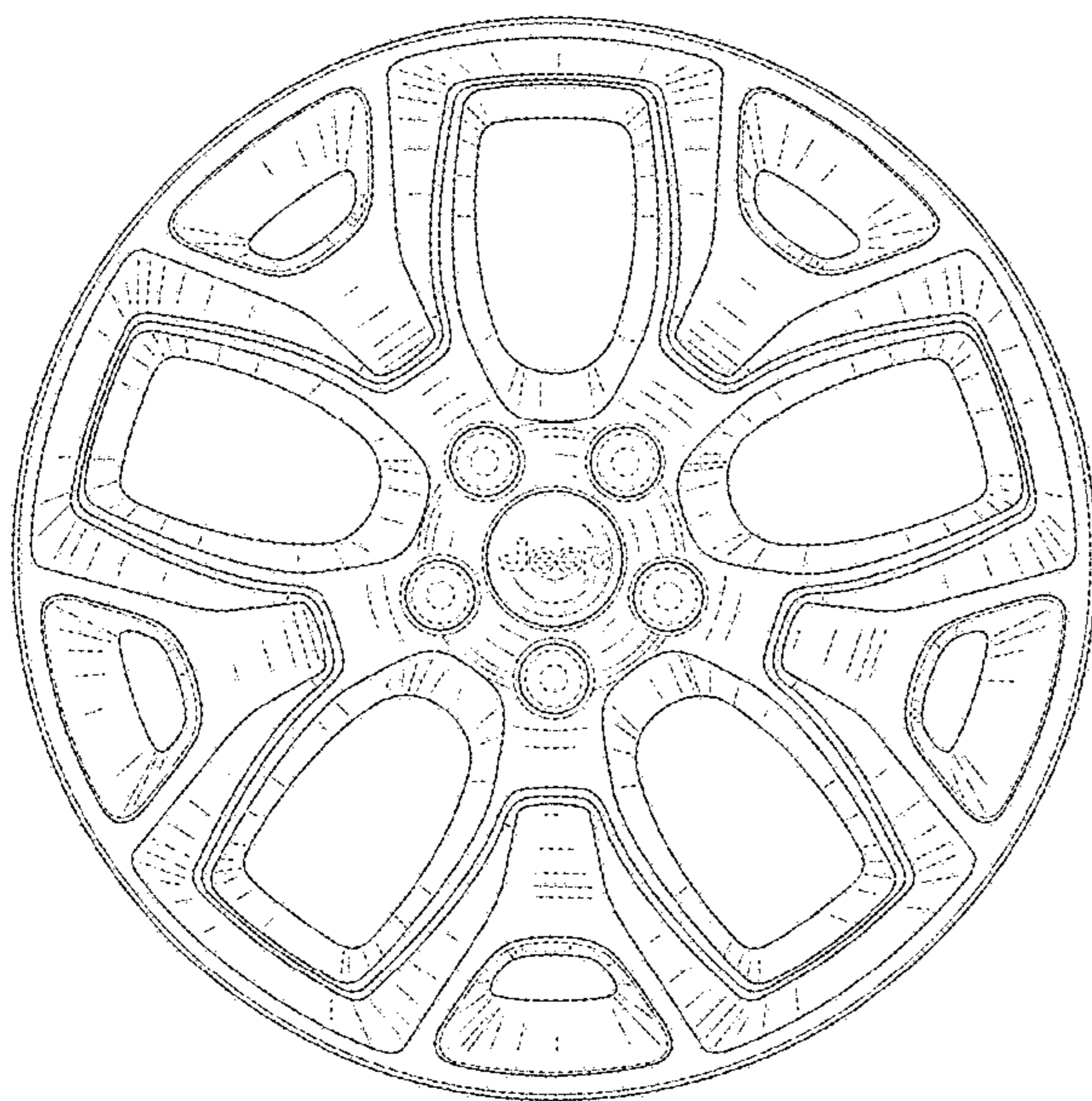

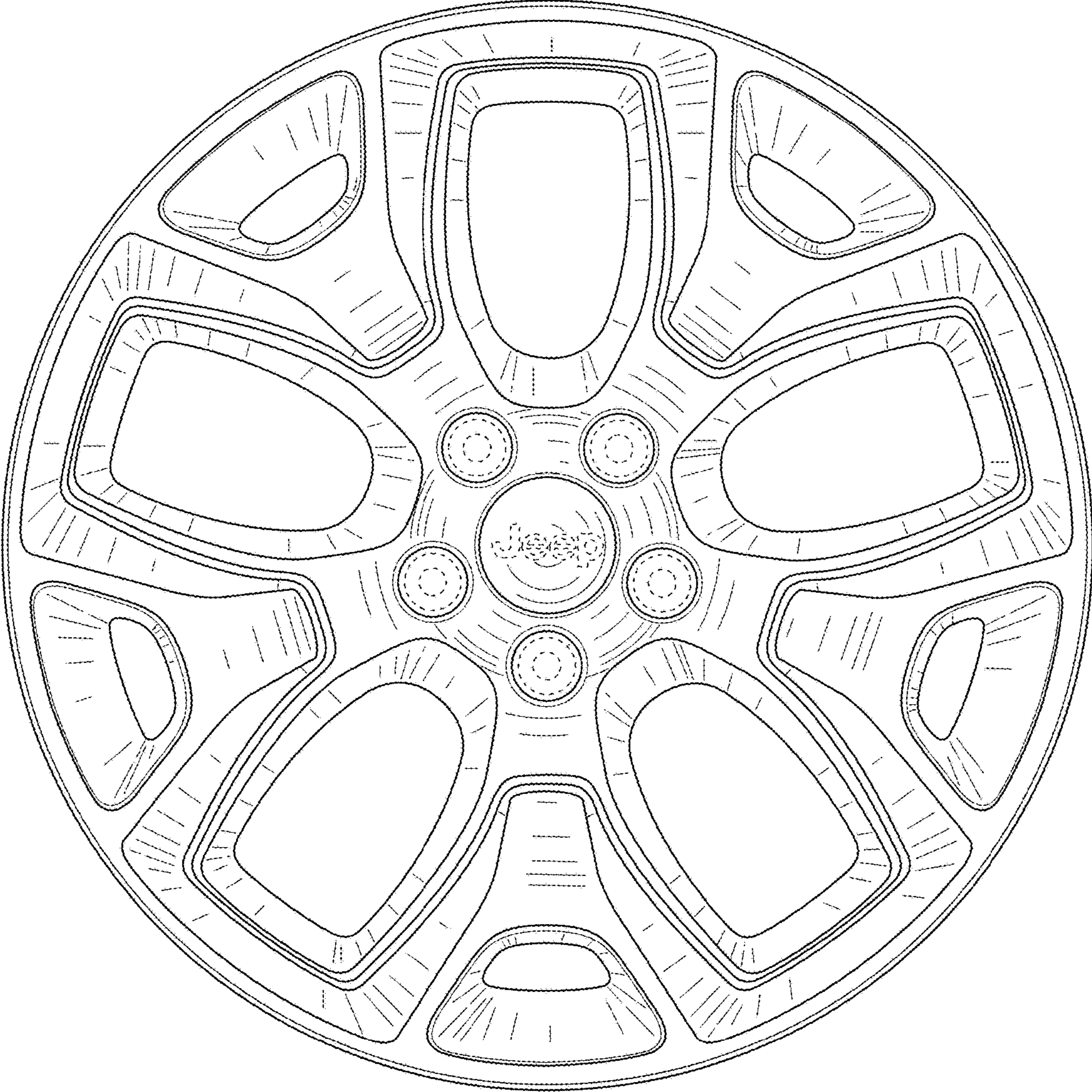

FIG. 1

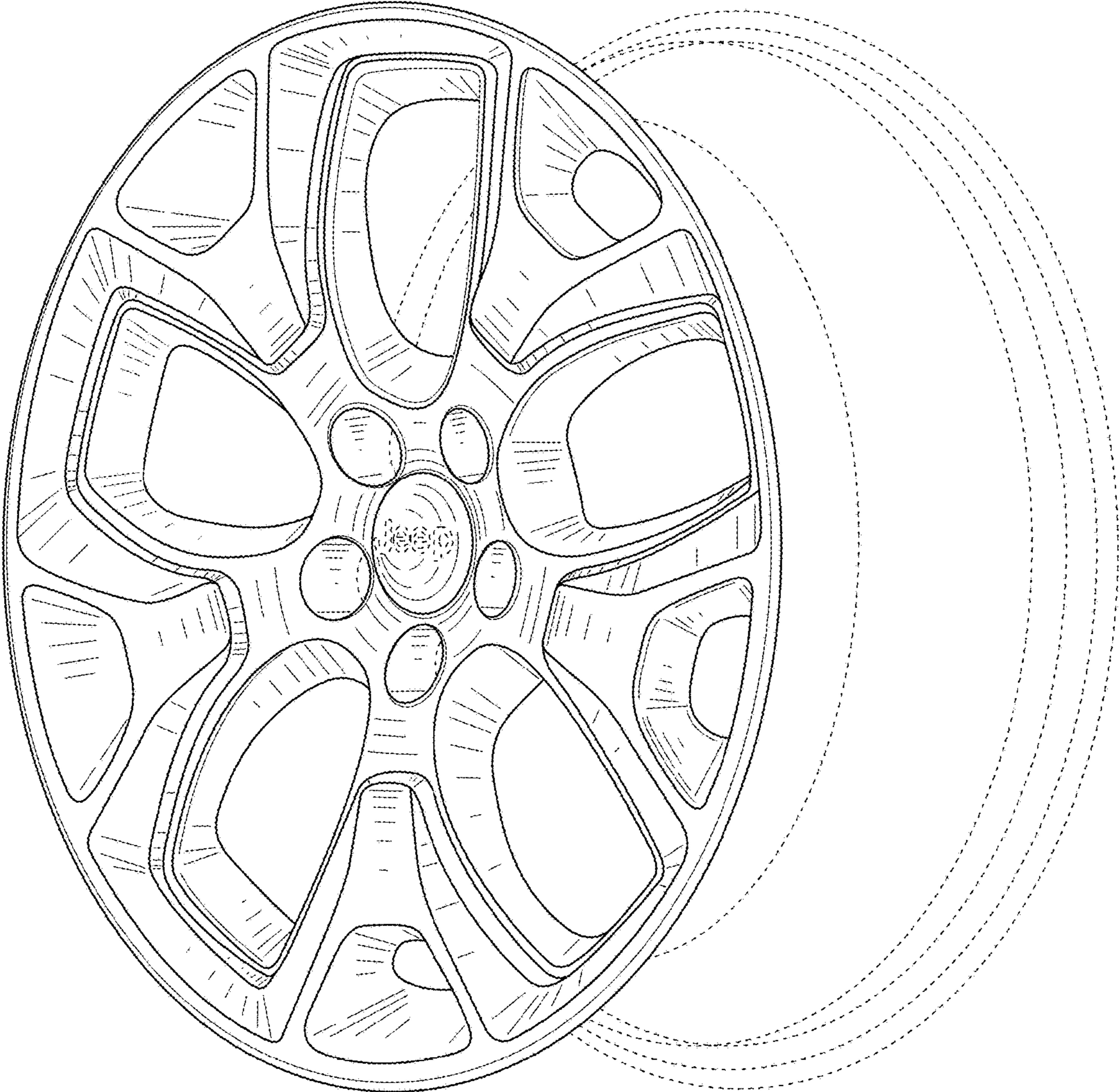

FIG. 2

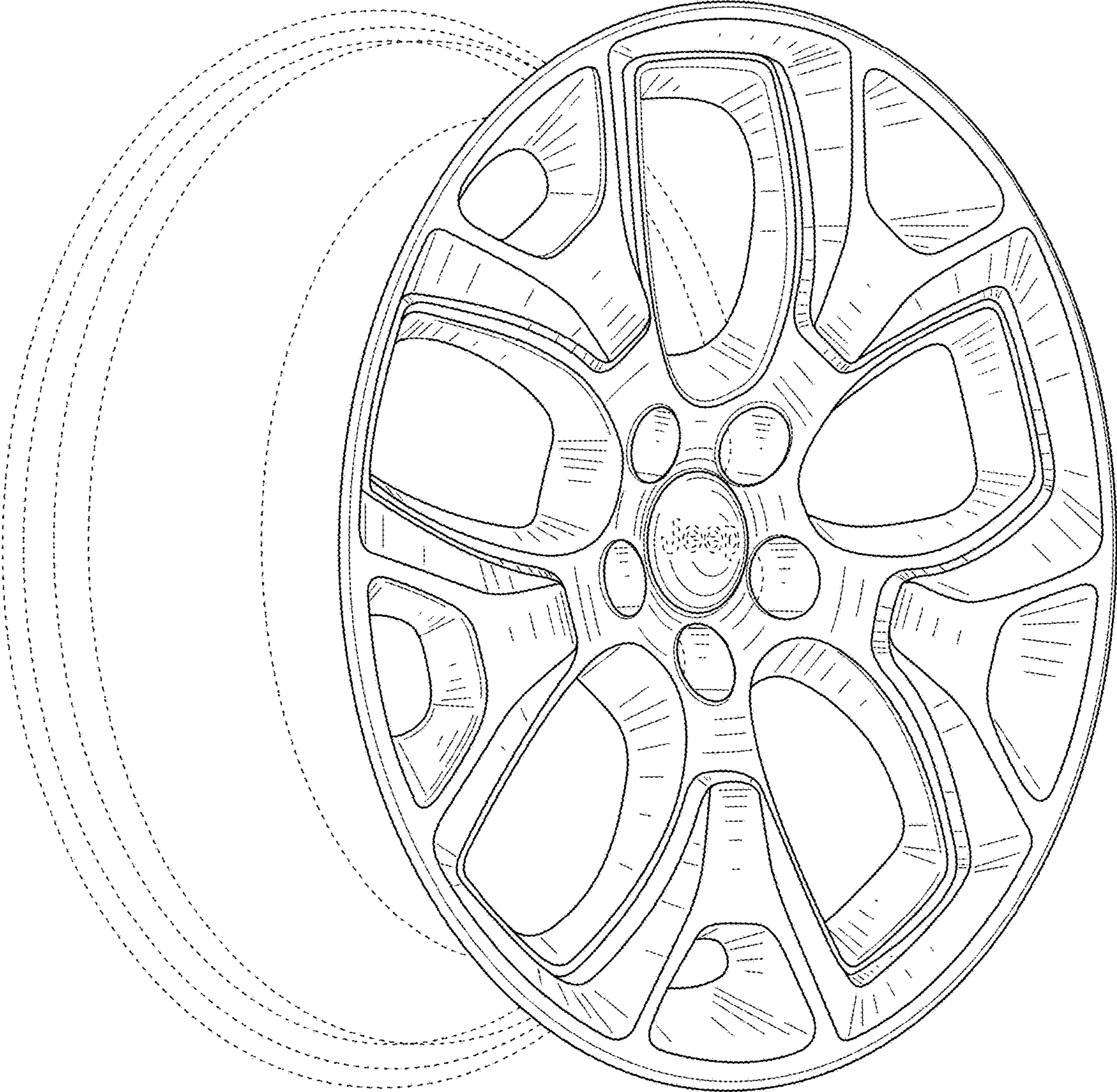

FIG. 3