



US00D780927S

(12) **United States Design Patent**
Masuda et al.

(10) **Patent No.:** **US D780,927 S**
(45) **Date of Patent:** **** Mar. 7, 2017**

(54) **FLUORESCENT X-RAY COATING THICKNESS GAUGE**

D515,707 S * 2/2006 Shinohara D24/216
D702,350 S * 4/2014 Nasella D24/158
D724,214 S * 3/2015 Ihara D24/158

(71) Applicant: **Hitachi High-Tech Science Corporation**, Minato-ku, Tokyo (JP)

* cited by examiner

(72) Inventors: **Ai Masuda**, Tokyo (JP); **Hiroyuki Noda**, Tokyo (JP); **Toshiyuki Takahara**, Tokyo (JP); **Isao Yagi**, Tokyo (JP)

Primary Examiner — Anhdao Doan

(74) *Attorney, Agent, or Firm* — Crowell & Moring LLP

(73) Assignee: **Hitachi High-Tech Science Corporation**, Tokyo (JP)

(57) **CLAIM**

The ornamental design for a fluorescent X-ray coating thickness gauge, as shown and described.

(**) Term: **15 Years**

DESCRIPTION

(21) Appl. No.: **29/529,938**

This application contains subject matter related to the following co-pending U.S. design patent application:

(22) Filed: **Jun. 11, 2015**

Application Ser. No. 29/529,941, filed herewith and entitled “Fluorescent X-ray Coating Thickness Gauge”.

(30) **Foreign Application Priority Data**

Dec. 12, 2014 (JP) 2014-027854

(51) **LOC (10) Cl.** **24-01**

(52) **U.S. Cl.**
USPC **D24/158**

(58) **Field of Classification Search**
USPC D24/158, 186, 187, 216, 107, 231–233;
D10/81

CPC A61B 6/485; G01N 23/043; G01N 23/223;
G01N 2223/076; G01N 2223/0766; G01N
2223/301; G01B 15/02

See application file for complete search history.

FIG. 1 is a perspective view of a fluorescent X-ray coating thickness gauge according to the design;

FIG. 2 is a front elevational view thereof;

FIG. 3 is a right side elevational view thereof;

FIG. 4 is a left side elevational view thereof;

FIG. 5 is a top plan view thereof;

FIG. 6 is a bottom plan view thereof;

FIG. 7 is a rear elevational view thereof; and,

FIG. 8 is a partially enlarged view of FIG. 2 showing the “power up” mode. The eleven circular elements within the interior rectangular feature are only visible in the “power-up” mode.

The dash-dot-dash broken lines shown in FIG. 2 and FIG. 8 are to identify the portion of the design shown in the enlarged view of FIG. 8. All other broken lines illustrate environmental subject matter and are for illustrative purposes only. The broken lines form no part of the claimed design.

(56) **References Cited**

U.S. PATENT DOCUMENTS

D247,226 S * 2/1978 Bruni D24/232
D320,450 S * 10/1991 Hicaro, Jr. D24/107

1 Claim, 8 Drawing Sheets

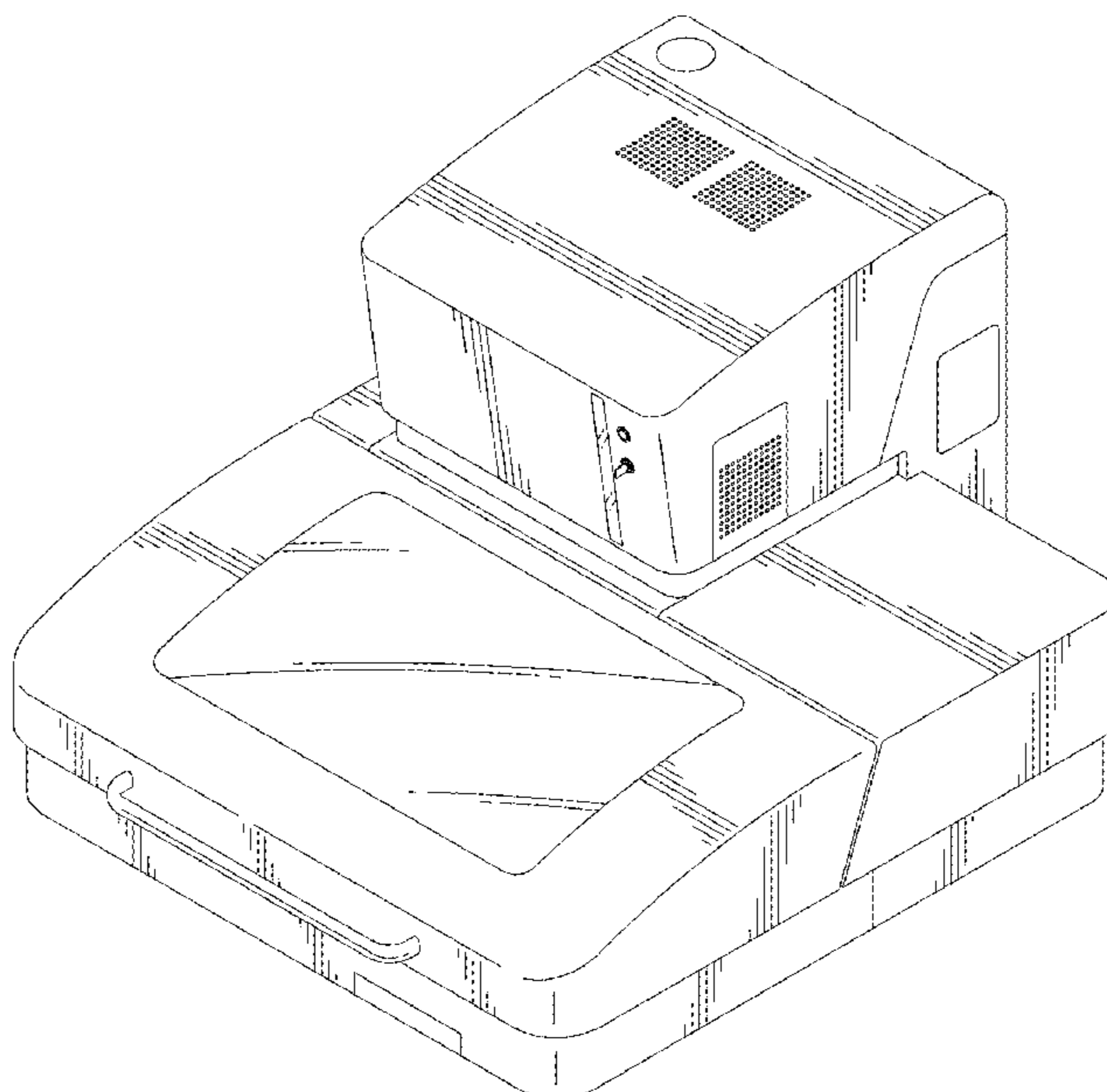

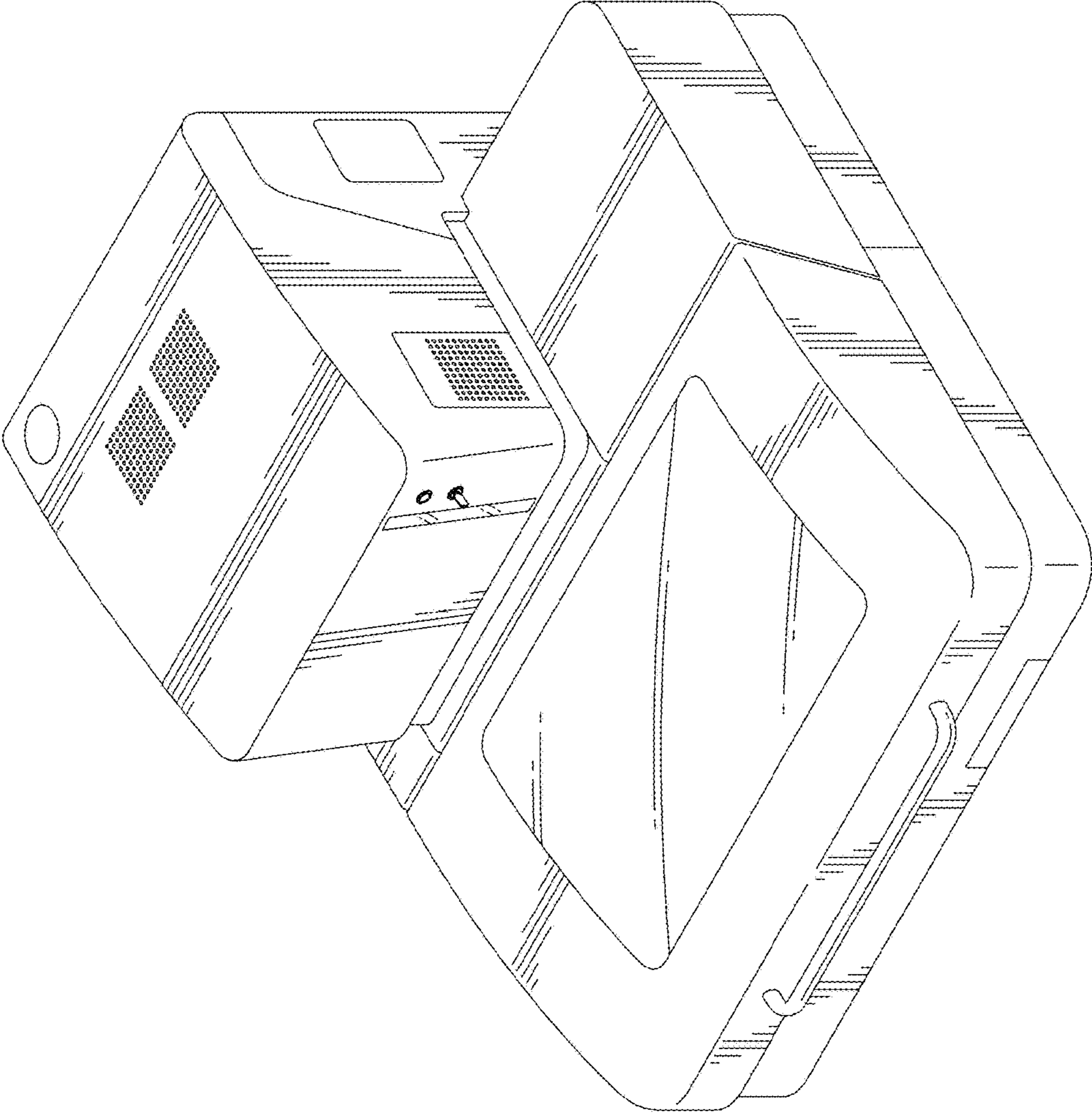

FIG. 1

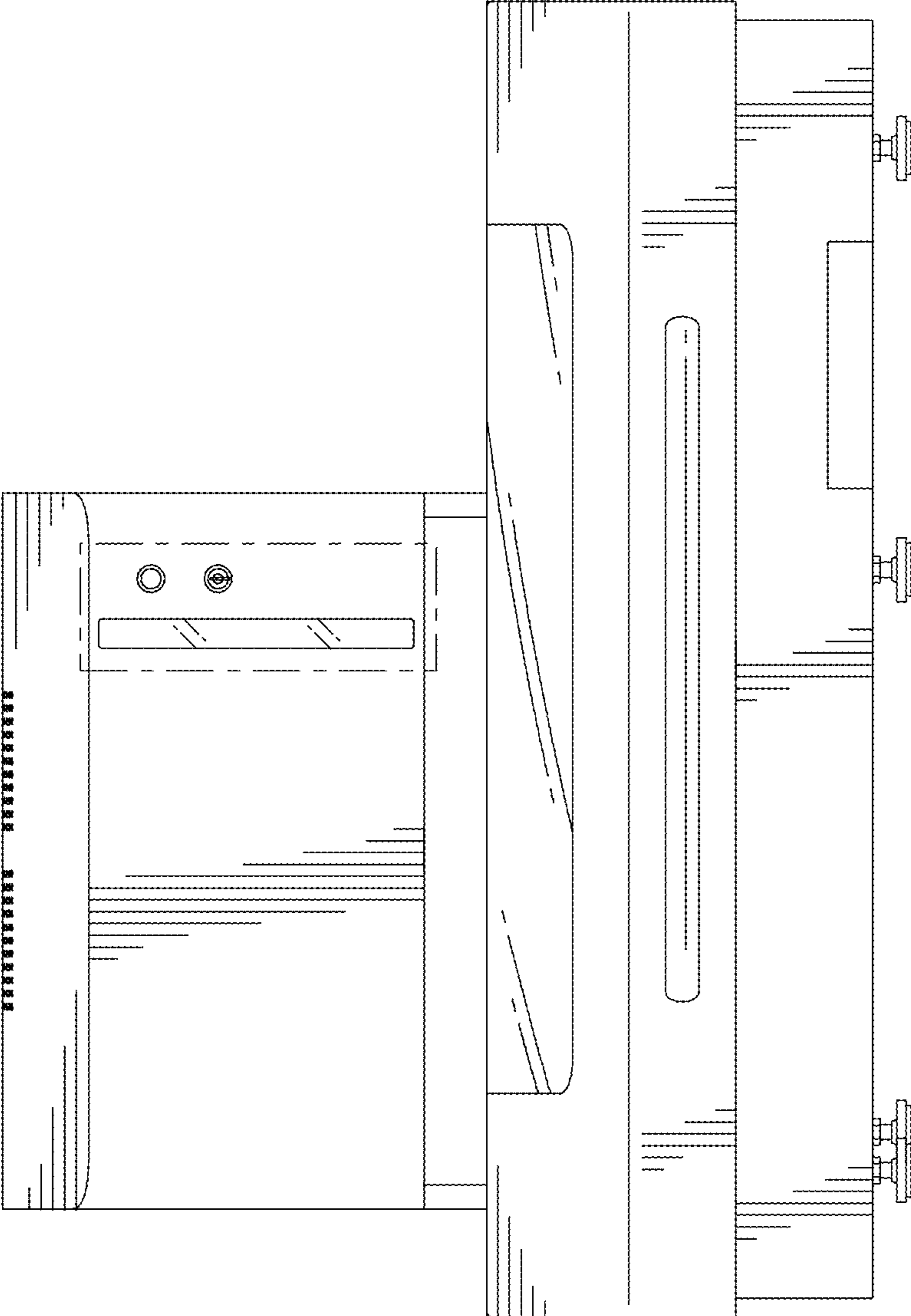

FIG. 2

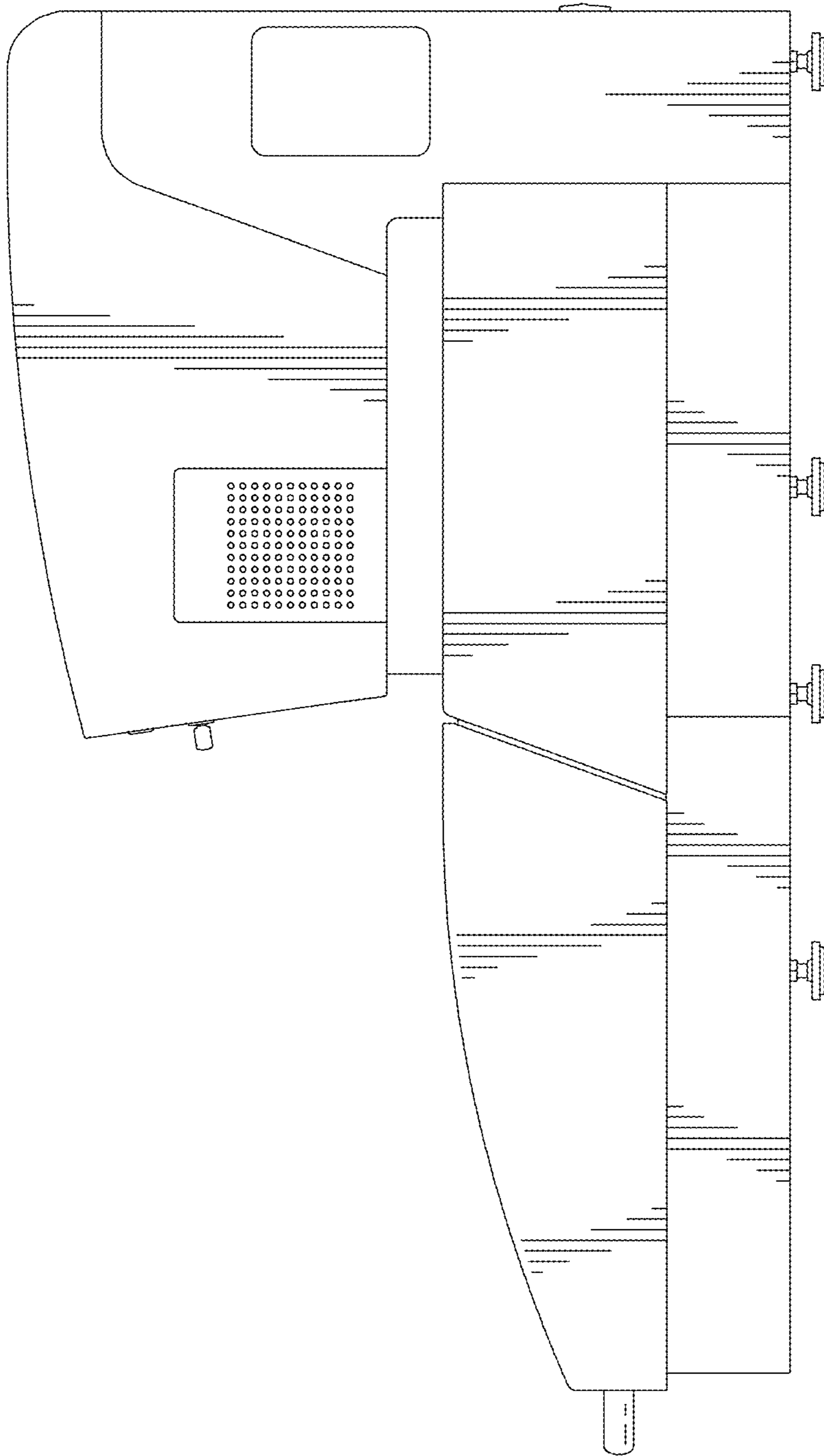

FIG. 3

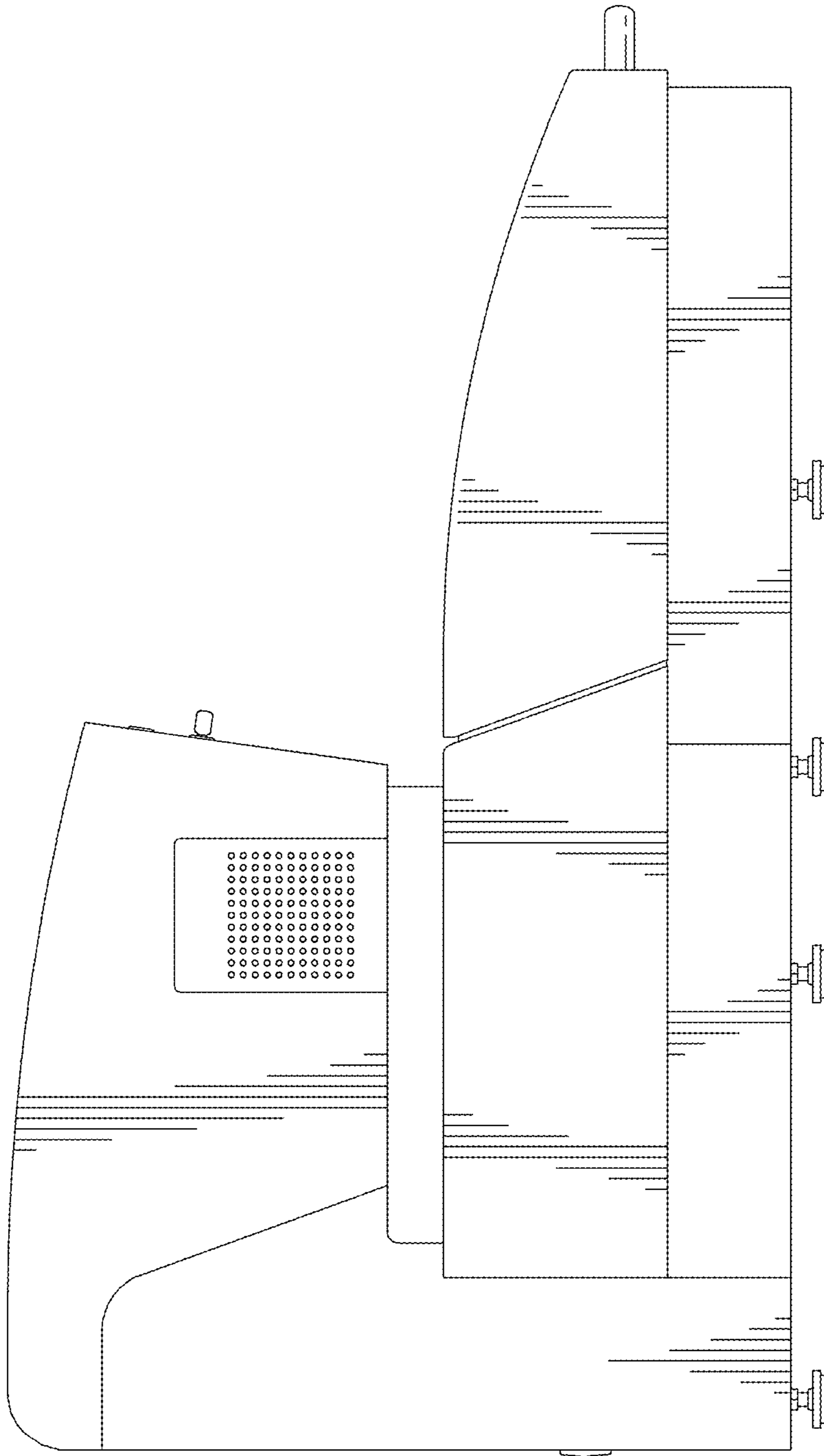

FIG. 4

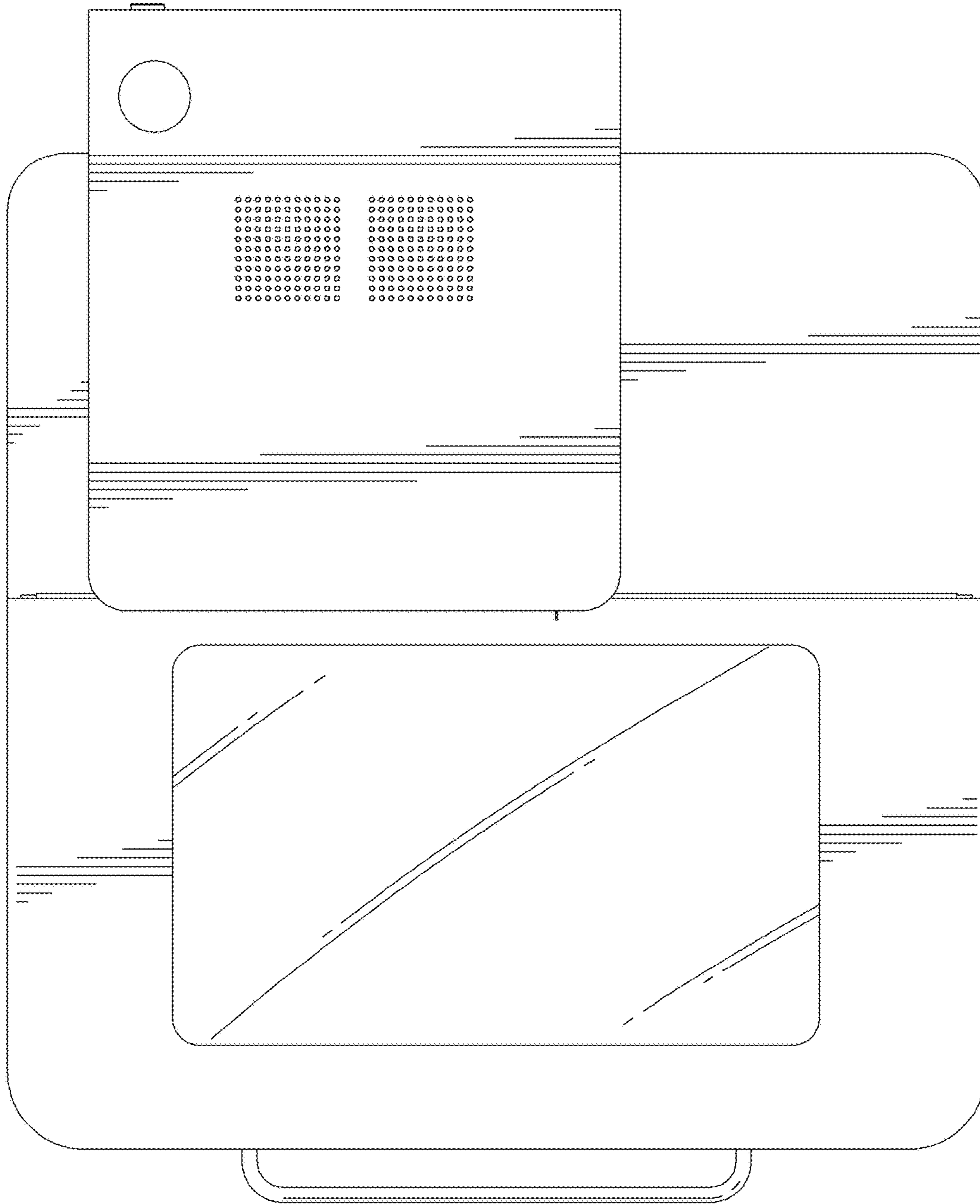

FIG. 5

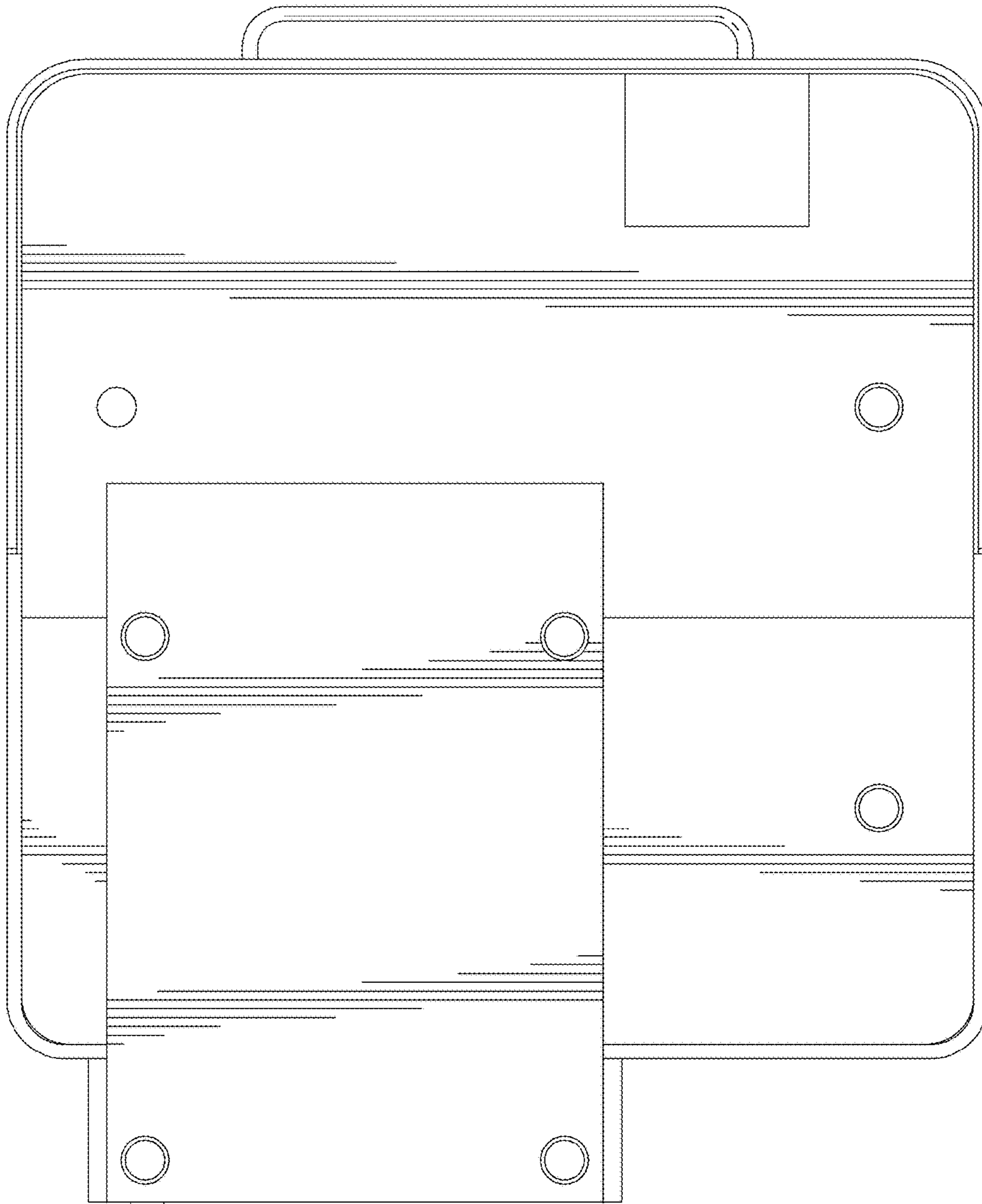

FIG. 6

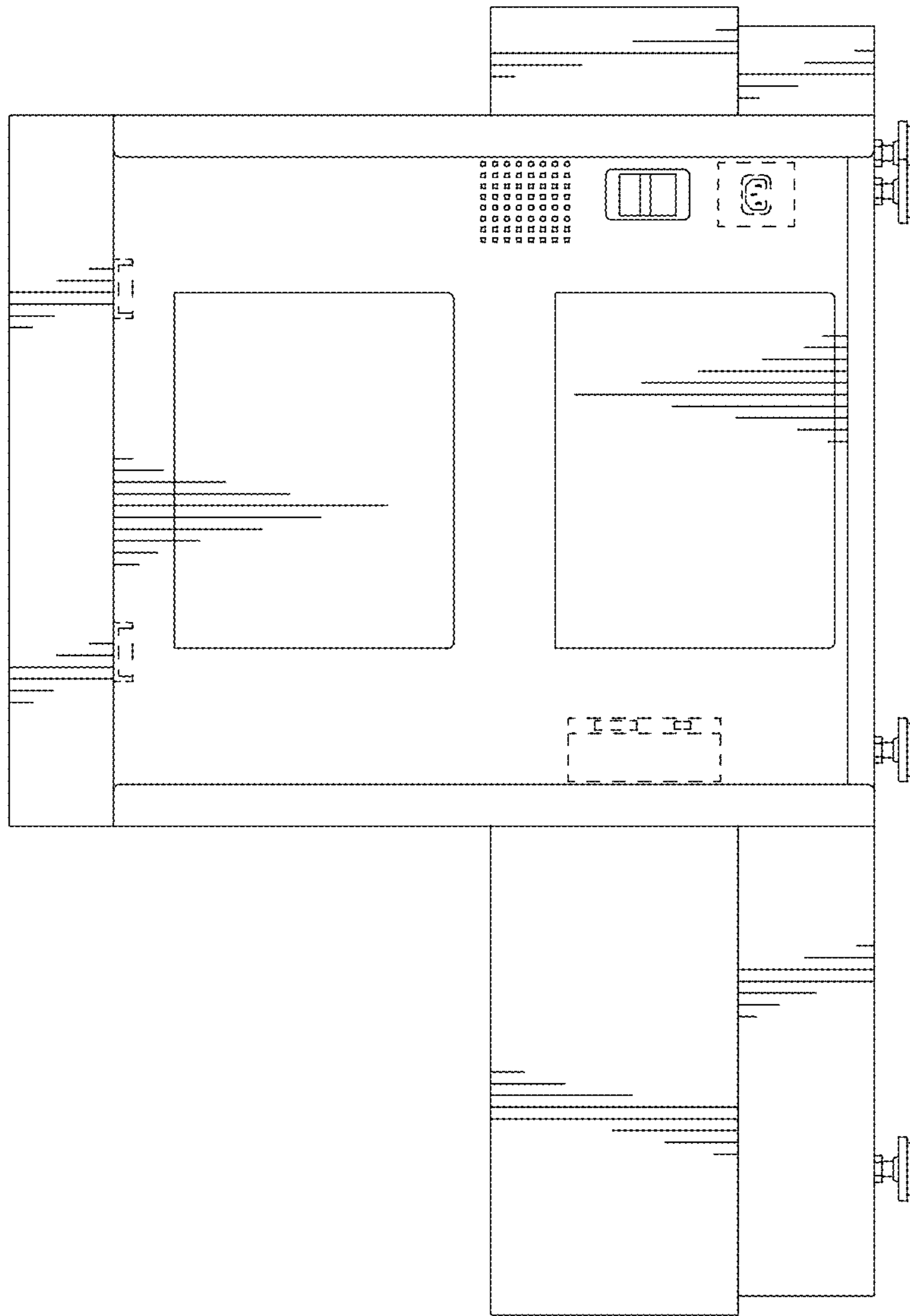

FIG. 7

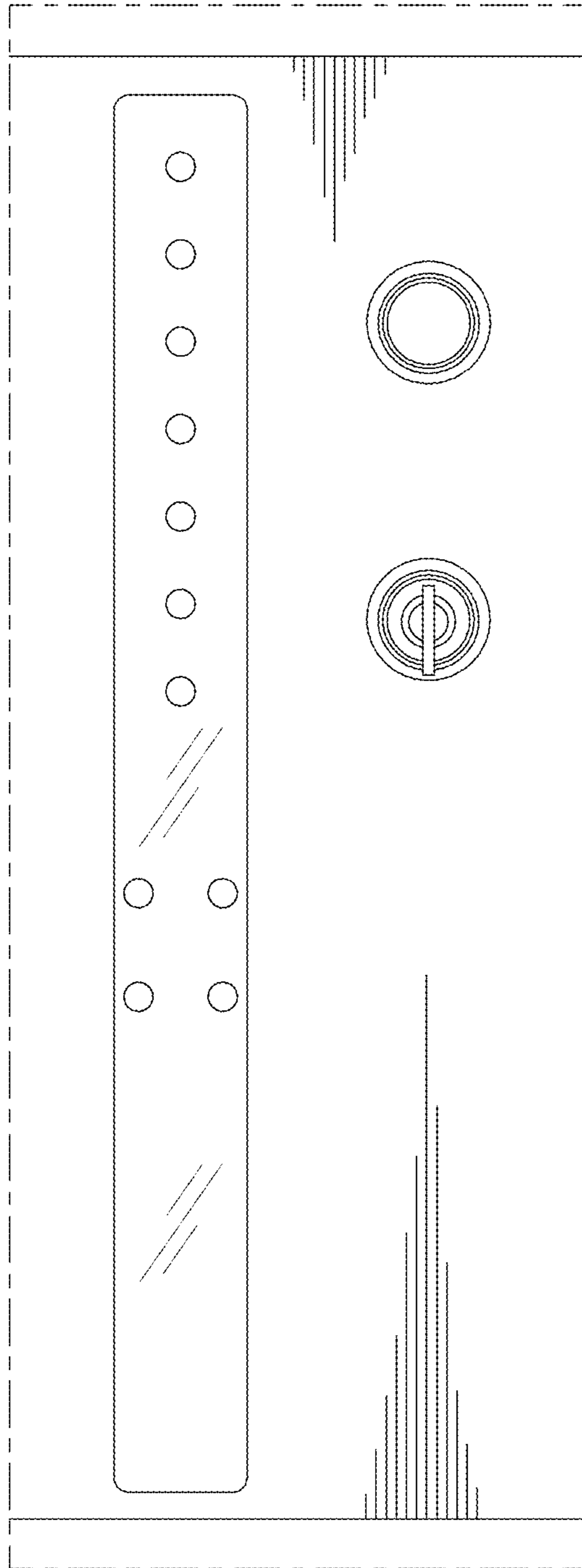

FIG. 8