



US00D780693S

(12) **United States Design Patent** (10) **Patent No.:** **US D780,693 S**  
**Altenburger et al.** (45) **Date of Patent:** **\*\* Mar. 7, 2017**

(54) **POWER TOOL**

D640,975 S \* 7/2011 Okuda ..... D13/103  
D643,809 S \* 8/2011 Okuda ..... D13/103  
8,191,648 B2 6/2012 Watanabe et al.

(71) Applicant: **AC (Macao Commercial Offshore) Limited**, Macau (MO)

(Continued)

(72) Inventors: **Ryan Altenburger**, Greenville, SC (US); **Brent Gregorich**, Anderson, SC (US); **Michael Buckner**, Central, SC (US)

FOREIGN PATENT DOCUMENTS

CA 2823207 7/2012  
CA 2872180 11/2013  
CA 2872182 11/2013

(73) Assignee: **AC (MACAO COMMERCIAL OFFSHORE) LIMITED**, Macau (MO)

*Primary Examiner* — Darlington Ly

(74) *Attorney, Agent, or Firm* — Michael Best & Friedrich LLP

(\*\*) Term: **15 Years**

(21) Appl. No.: **29/533,886**

(57) **CLAIM**

(22) Filed: **Jul. 22, 2015**

The ornamental design for a power tool, as shown and described.

(51) **LOC (10) Cl.** ..... **13-02**

(52) **U.S. Cl.**

USPC ..... **D13/120; D8/68**

(58) **Field of Classification Search**

USPC ..... D8/68, 70; D13/102-107, 110, 118-122, D13/184; 429/96-100, 163, 175-176, 429/187

CPC ..... H02J 7/0045; H01R 31/06; H01M 2/1022  
See application file for complete search history.

**DESCRIPTION**

FIG. 1 is a bottom, rear, and right side perspective view of a power tool showing our new design; FIG. 2 is a bottom, rear, and left side perspective view thereof; FIG. 3 is a bottom, front, and right side perspective view thereof; FIG. 4 is a bottom, front, and left side perspective view thereof; FIG. 5 is a bottom plan view thereof; and, FIG. 6 is a rear elevation view thereof.

The portions of the power tool shown in broken lines are included for the purpose of illustrating environment and form no part of the claimed design. The portions of the power tool shown in broken lines having unequal length segments illustrate the boundary of the claimed design and form no part of the claimed design.

(56) **References Cited**

U.S. PATENT DOCUMENTS

5,057,112 A 10/1991 Sherman et al.  
D501,823 S \* 2/2005 Johnson ..... D13/107  
7,320,368 B2 1/2008 Watanabe  
D588,986 S \* 3/2009 Zhang ..... D13/103  
7,513,402 B2 4/2009 Miyashita et al.  
D601,088 S \* 9/2009 Scheucher ..... D13/103  
D610,085 S \* 2/2010 Sweeney ..... D13/107  
7,659,694 B2 \* 2/2010 Griffin ..... H01M 2/1022  
320/112  
7,845,426 B2 12/2010 Jung et al.  
D639,730 S \* 6/2011 Kawase ..... D13/103  
D640,196 S \* 6/2011 Shuang ..... D13/103

**1 Claim, 6 Drawing Sheets**

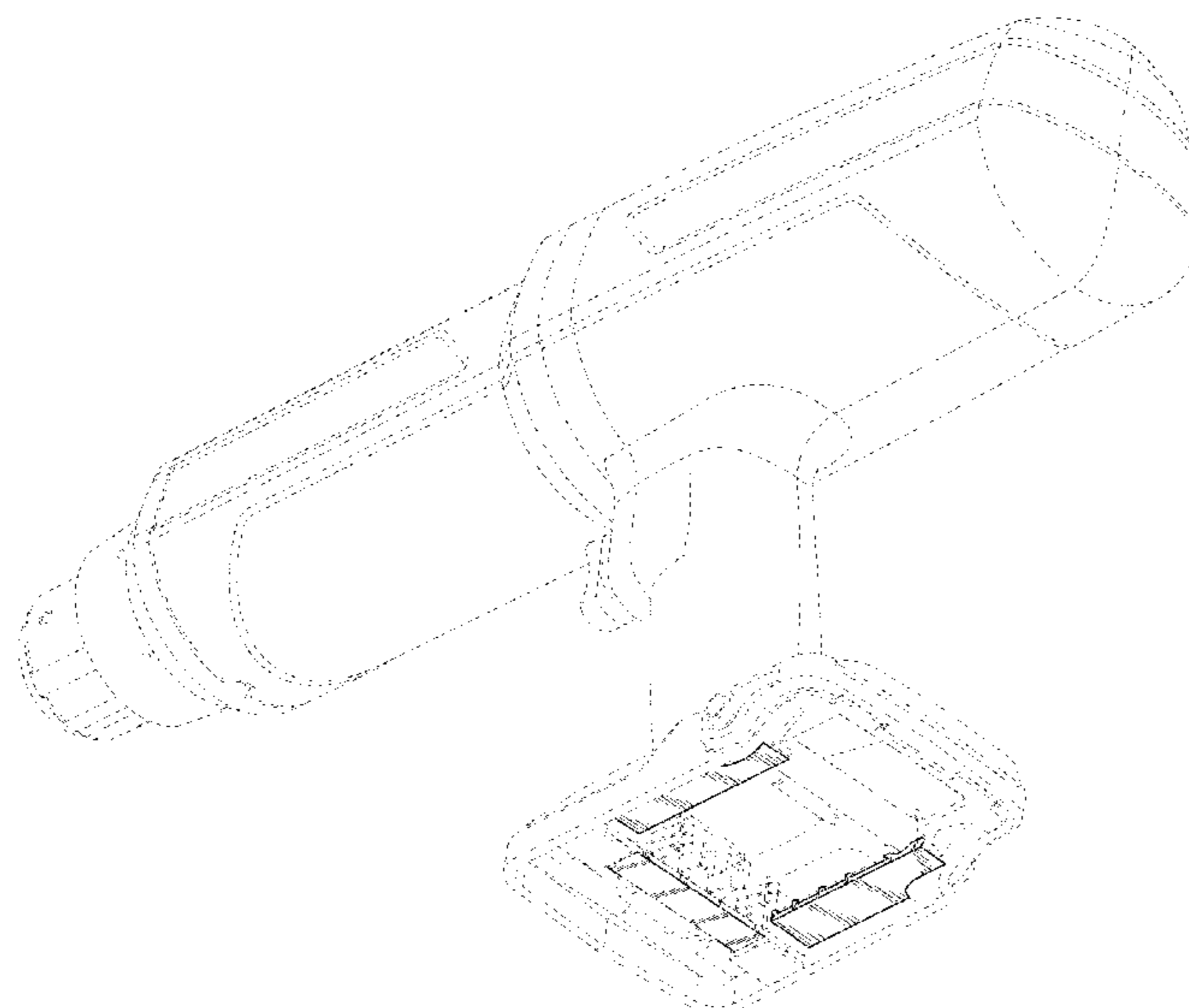

(56)

**References Cited**

U.S. PATENT DOCUMENTS

D668,219	S *	10/2012	Zhao .....	D13/107
D671,892	S *	12/2012	Keith, Jr. ....	D13/133
8,393,409	B2	3/2013	Pedicini	
D683,606	S *	6/2013	Keith, Jr. ....	D8/70
D692,741	S *	11/2013	McRoberts .....	D8/70
D698,312	S *	1/2014	Miller .....	D13/119
D714,722	S *	10/2014	Miller .....	D13/107
8,936,106	B2	1/2015	Pedicini	
D748,577	S *	2/2016	Marino .....	D13/118
D754,510	S *	4/2016	Marino .....	D13/103
2005/0153596	A1 *	7/2005	VanWambeke .....	B25F 5/02 439/500
2006/0185865	A1	8/2006	Jung et al.	
2010/0282483	A1	11/2010	Jung et al.	
2013/0186666	A1	7/2013	Yoshino et al.	
2014/0100687	A1	4/2014	Ekstrom et al.	

\* cited by examiner

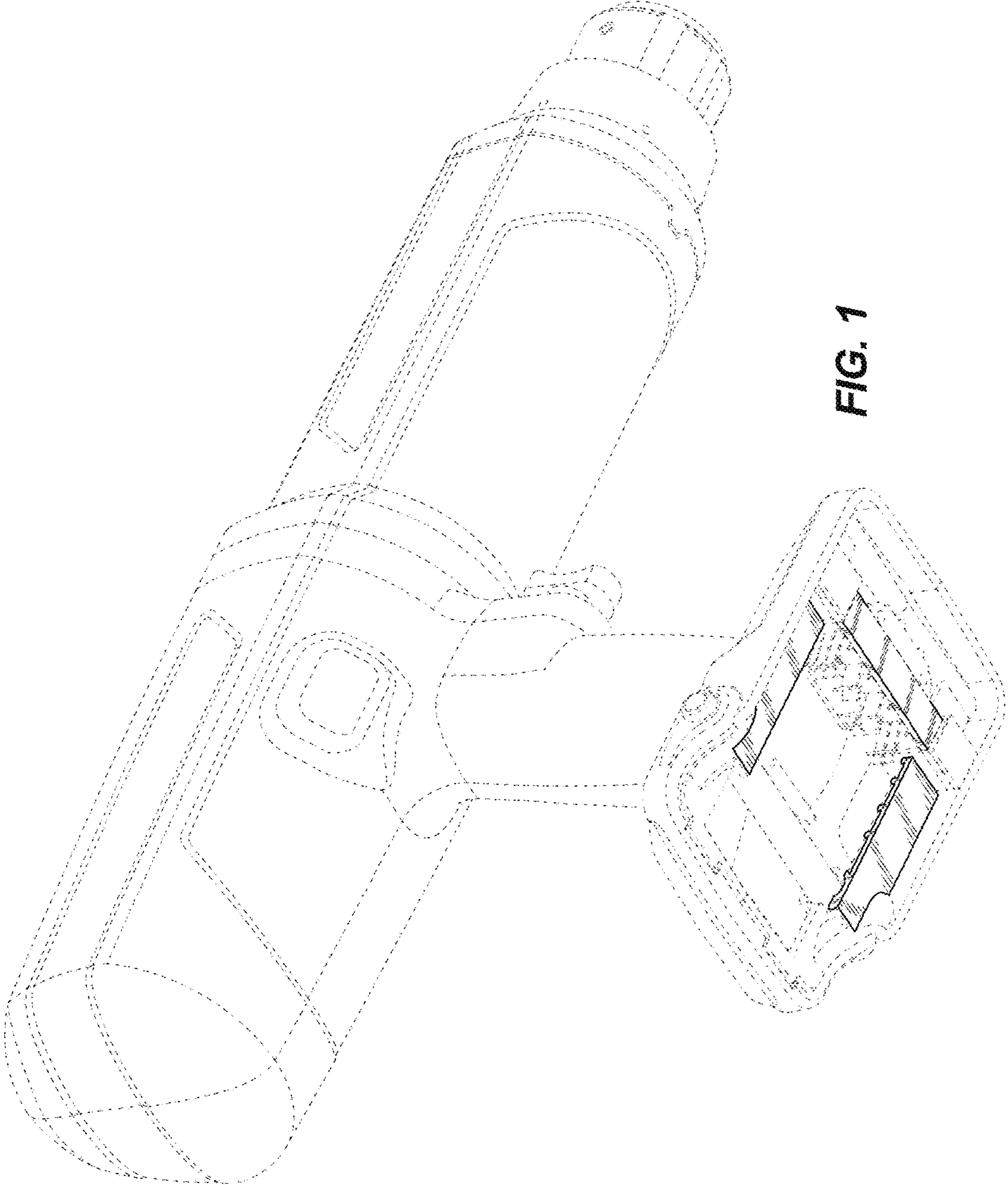

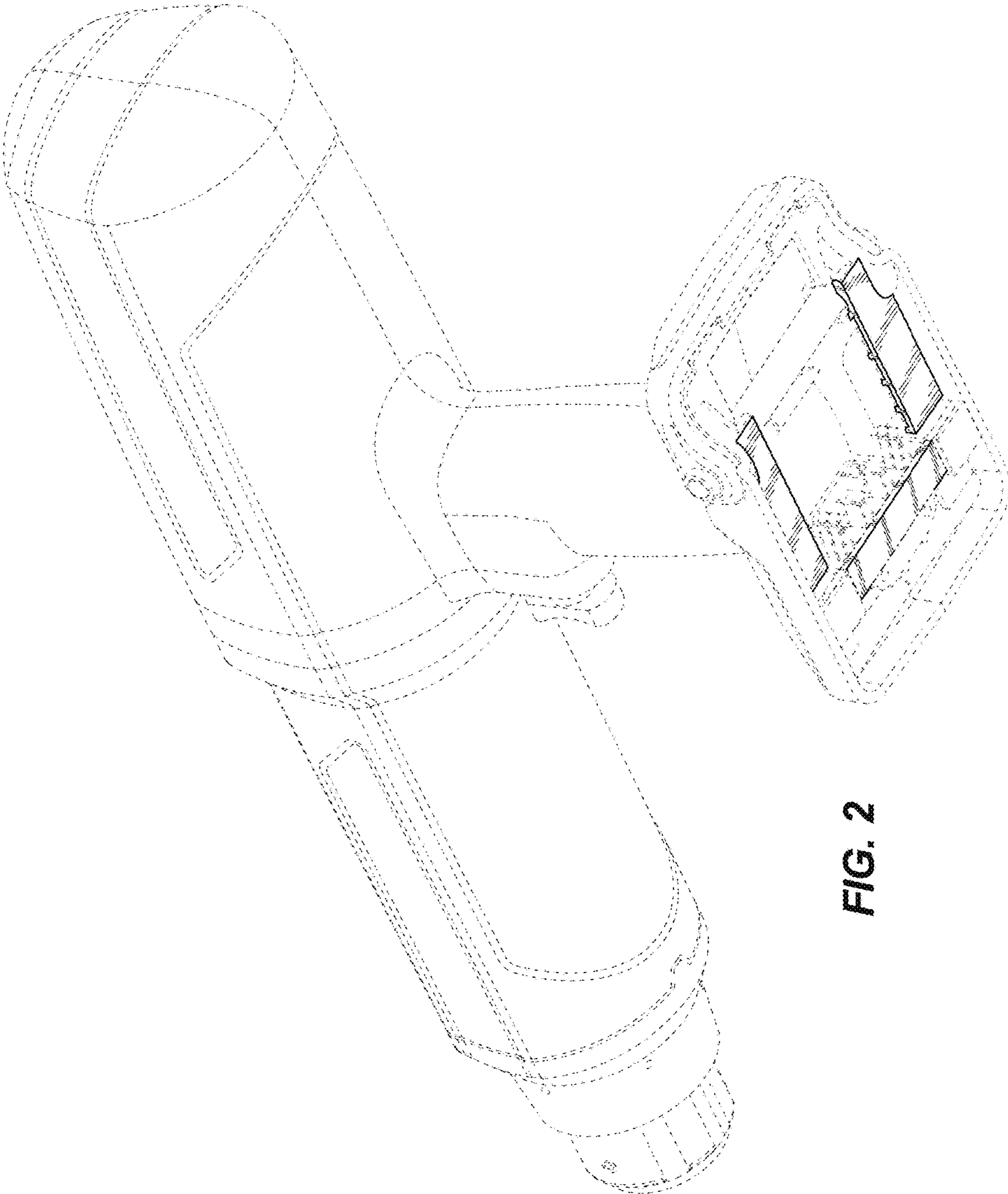

FIG. 2



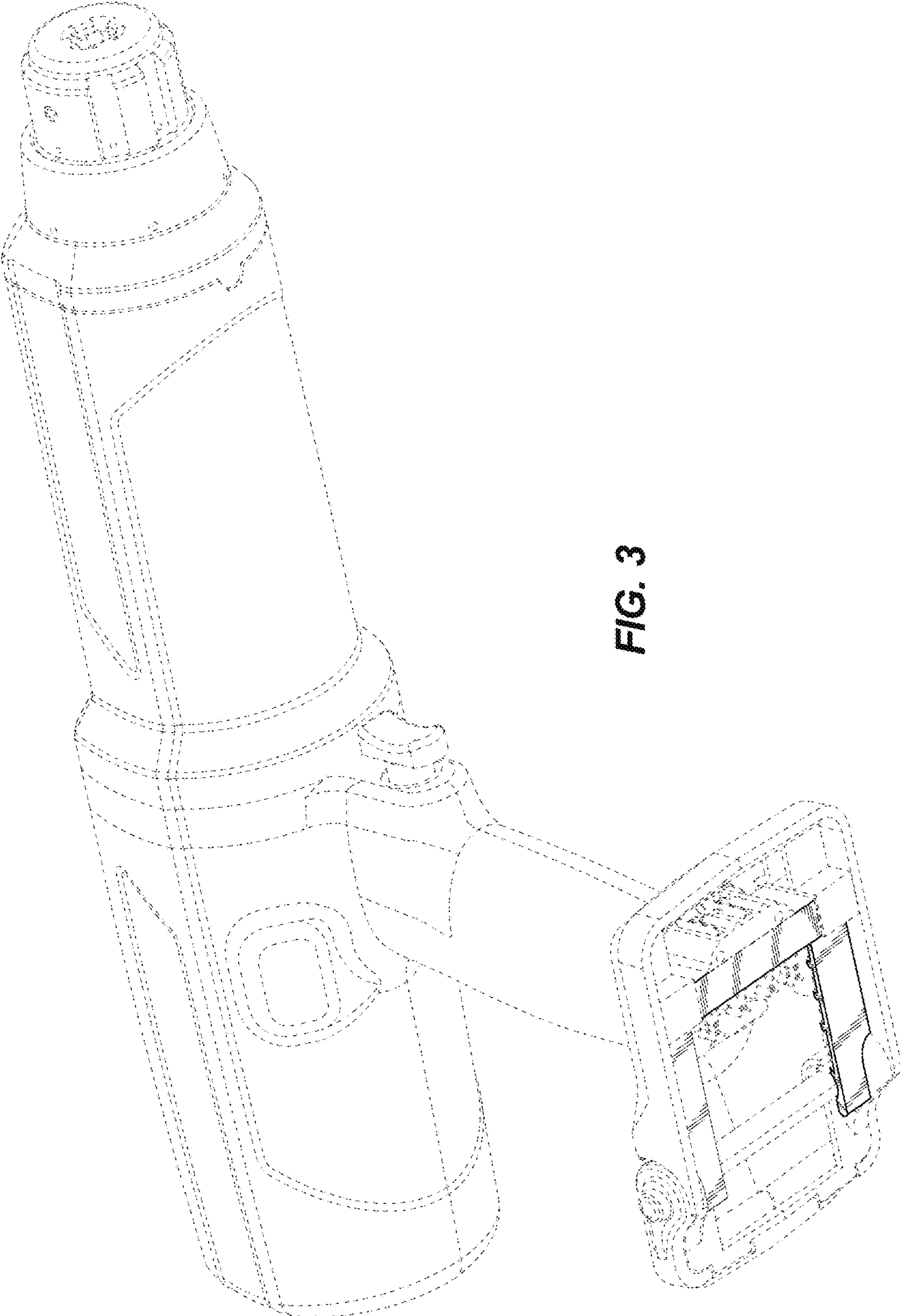

FIG. 3

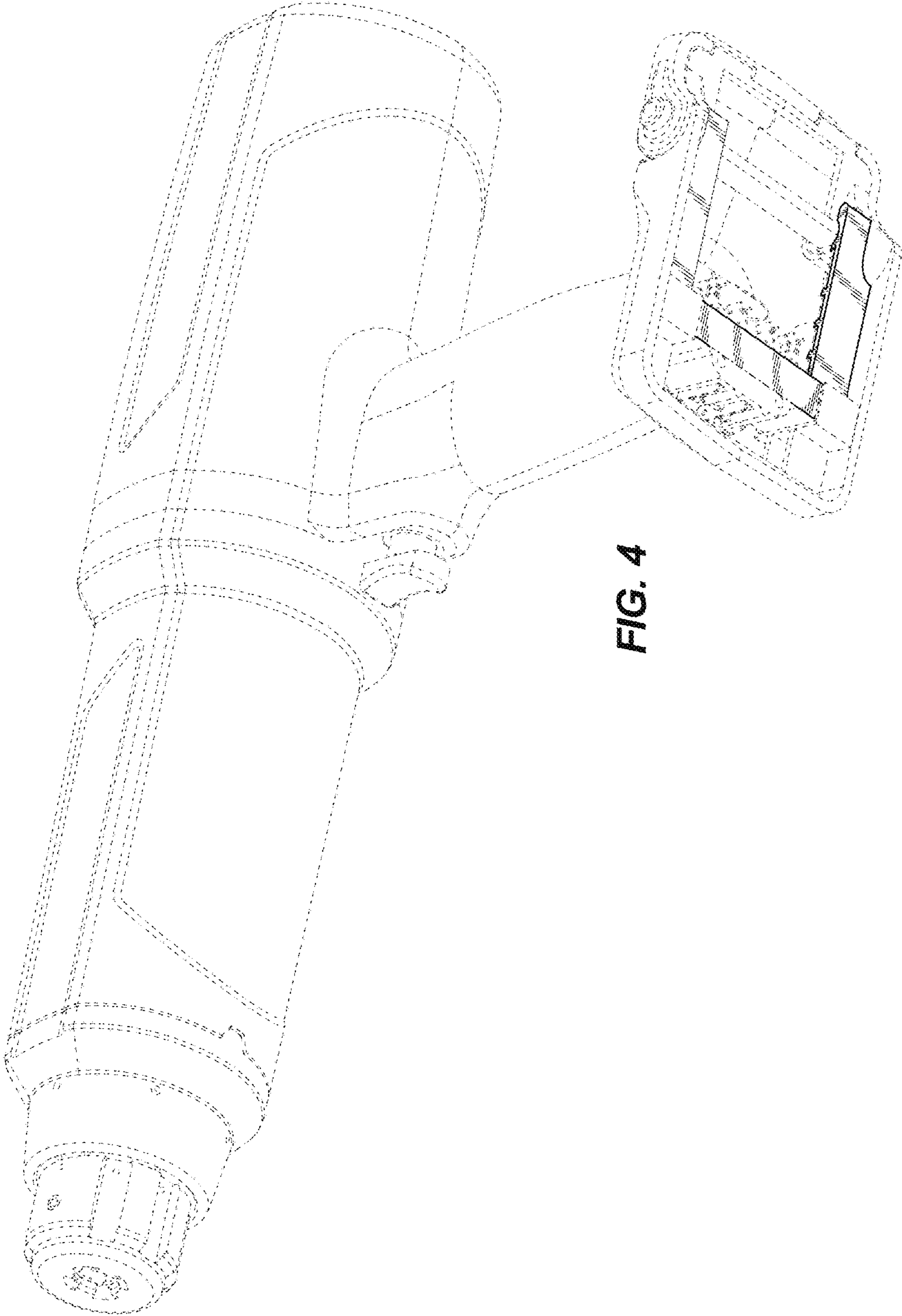

FIG. 4

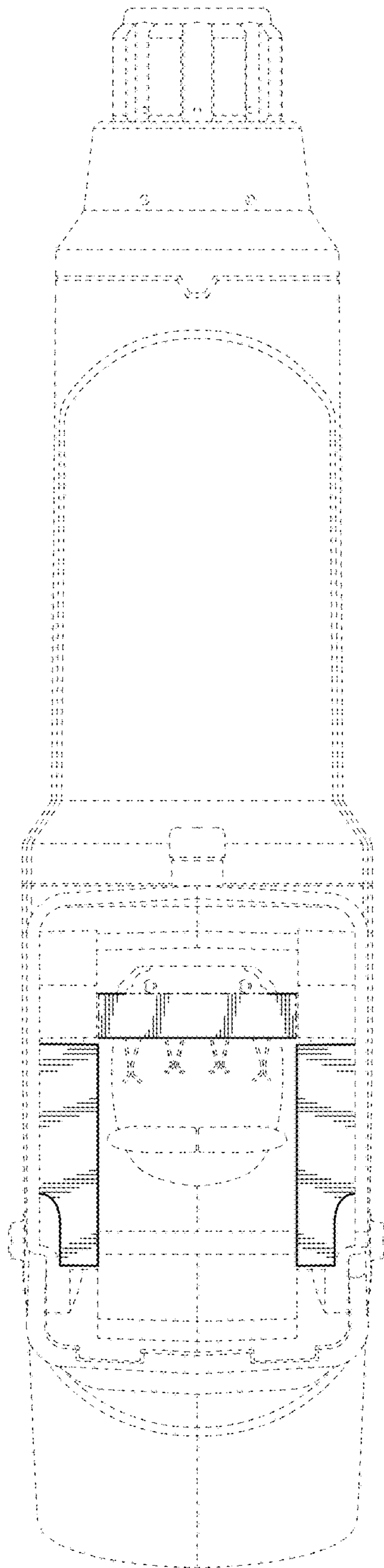
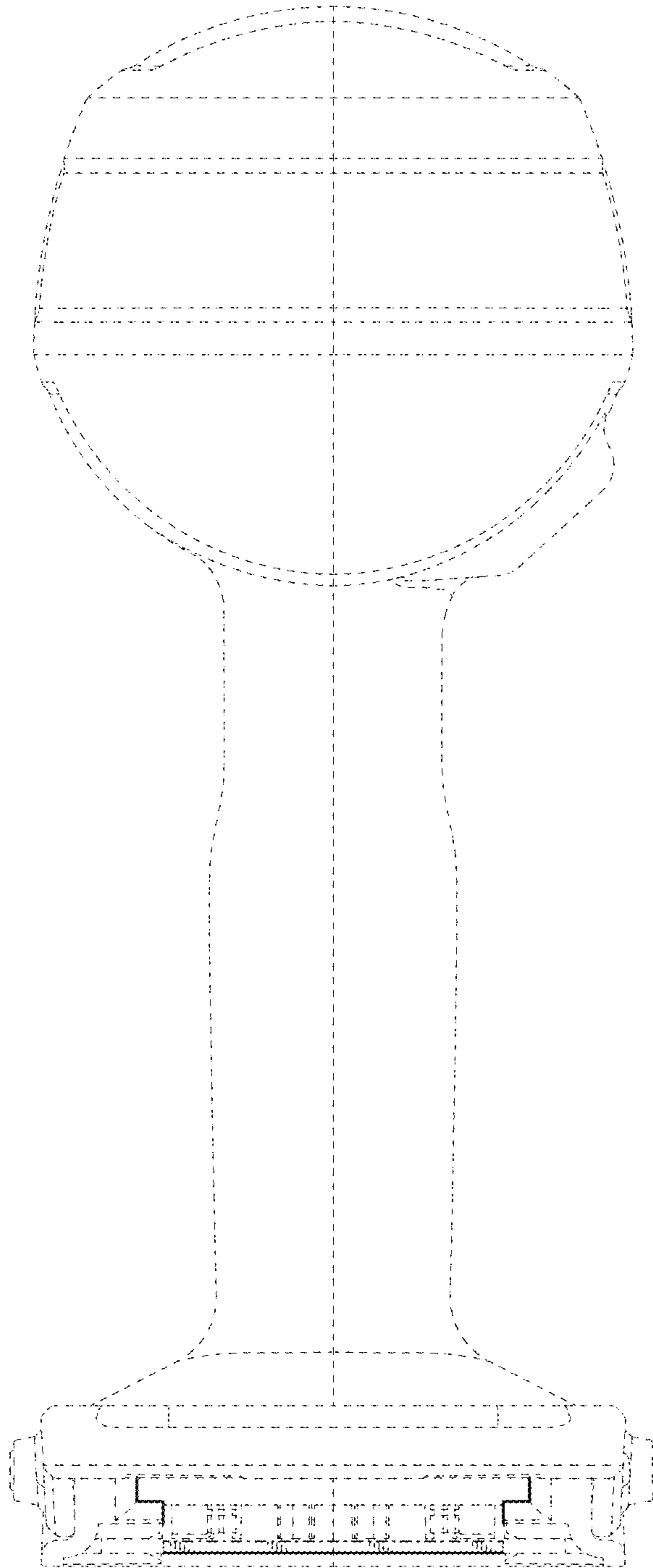

FIG. 5



**FIG. 6**