



US00D780639S

(12) **United States Design Patent**
Calley et al.

(10) **Patent No.:** **US D780,639 S**
(45) **Date of Patent:** **** Mar. 7, 2017**

(54) **MOTORCYCLE GUARD**
(71) Applicants: **Jason Calley**, Kingwood, TX (US);
Mikael Smith, Kingwood, TX (US)
(72) Inventors: **Jason Calley**, Kingwood, TX (US);
Mikael Smith, Kingwood, TX (US)
(**) Term: **15 Years**

(21) Appl. No.: **29/529,400**

(22) Filed: **Jun. 5, 2015**

(51) **LOC (10) Cl.** **12-11**

(52) **U.S. Cl.**
USPC **D12/114**

(58) **Field of Classification Search**
USPC D12/114, 117, 118, 123, 126, 127, 194,
D12/110; D15/5; D21/819, 821
CPC B62J 27/00; B62J 23/00; B62J 17/00;
B62K 25/02; B62K 21/02
See application file for complete search history.

(56) **References Cited**

U.S. PATENT DOCUMENTS

D27,105 S *	5/1897	Meilink	D12/117
629,667 A	7/1899	Denbigh		
3,762,982 A	10/1973	Whittington		
4,105,220 A	8/1978	Pacific		
4,138,132 A	2/1979	Doyle		
D313,774 S	1/1991	Hauer		
5,183,281 A	2/1993	Stephens		
D340,432 S *	10/1993	Osborne	74/551.8
D341,343 S	11/1993	Netz		
D350,921 S *	9/1994	Carroll	D12/114
5,397,146 A	3/1995	Fischer		
5,687,773 A	11/1997	Ryan et al.		
D409,119 S *	5/1999	Fervoy	D12/126
6,186,902 B1 *	2/2001	Briggs	A63G 21/18 472/117

6,419,039 B1	7/2002	Wagner		
6,554,715 B1 *	4/2003	Gernstein	A63G 21/18 472/117
D483,710 S *	12/2003	James	D12/194
D491,112 S	6/2004	Francis et al.		
6,837,509 B2	1/2005	Welch et al.		
D510,059 S *	9/2005	Hickman	D12/117
D518,760 S *	4/2006	Johnson	D12/126
D523,787 S *	6/2006	Johnson	D12/126
D527,692 S *	9/2006	Yoshimatsu	D12/118
7,144,030 B2	12/2006	Buell et al.		
D575,682 S *	8/2008	Norment	D12/126
D591,207 S *	4/2009	Madden	D12/117
7,637,520 B2	12/2009	Madden		

(Continued)

Primary Examiner — George D Kirschbaum

Assistant Examiner — Clese Moore, Jr.

(74) *Attorney, Agent, or Firm* — Buche & Associates,
P.C.; John K. Buche; Scott D. Compton

(57) **CLAIM**

The ornamental design for a motorcycle guard, as shown and described.

DESCRIPTION

FIG. 1 is a perspective view of a motorcycle guard showing my new design;
FIG. 2 is a top view thereof;
FIG. 3 is a bottom view thereof;
FIG. 4 is a left side view thereof;
FIG. 5 is a right side view thereof;
FIG. 6 is a front view thereof;
FIG. 7 is a back view thereof;
FIG. 8 is an environmental perspective view thereof; and,
FIG. 9 is an environmental perspective view thereof.
The broken lines shown illustrate portions of the motorcycle guard and environment that form no part of the claimed design.

1 Claim, 5 Drawing Sheets

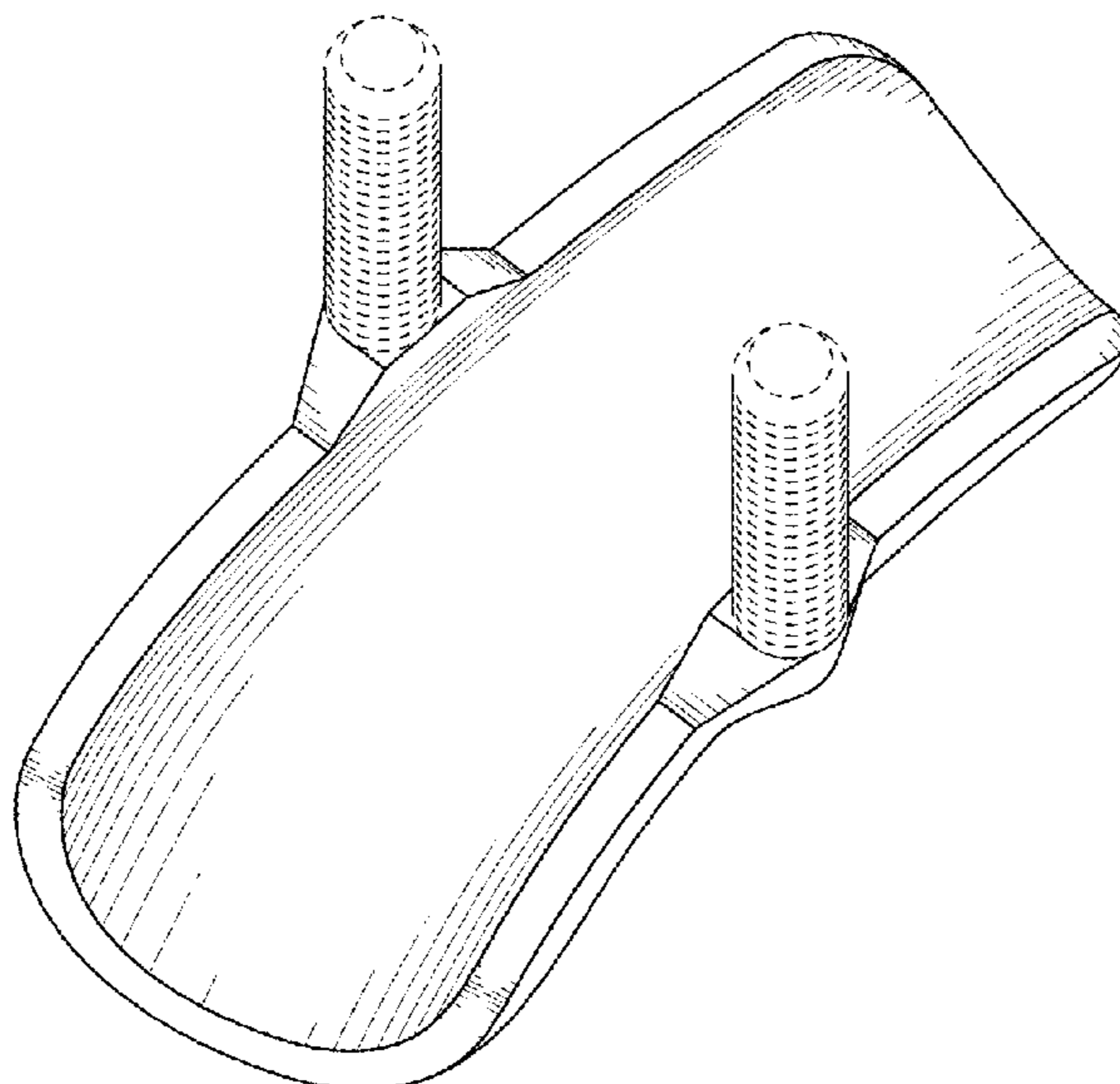

(56)

References Cited

U.S. PATENT DOCUMENTS

D613,655	S *	4/2010	Burkhart	D12/194
D626,049	S *	10/2010	Emler	D12/194
2004/0046359	A1	3/2004	Welch et al.	
2012/0091686	A1	4/2012	Hutchinson	
2012/0133115	A1	5/2012	Roziere et al.	
2014/0174581	A1 *	6/2014	Shimomura	B60K 13/04 138/103
2015/0145232	A1 *	5/2015	Carreira	B62K 21/02 280/304.3
2016/0166942	A1 *	6/2016	Fisher	A63G 21/18 472/88

* cited by examiner

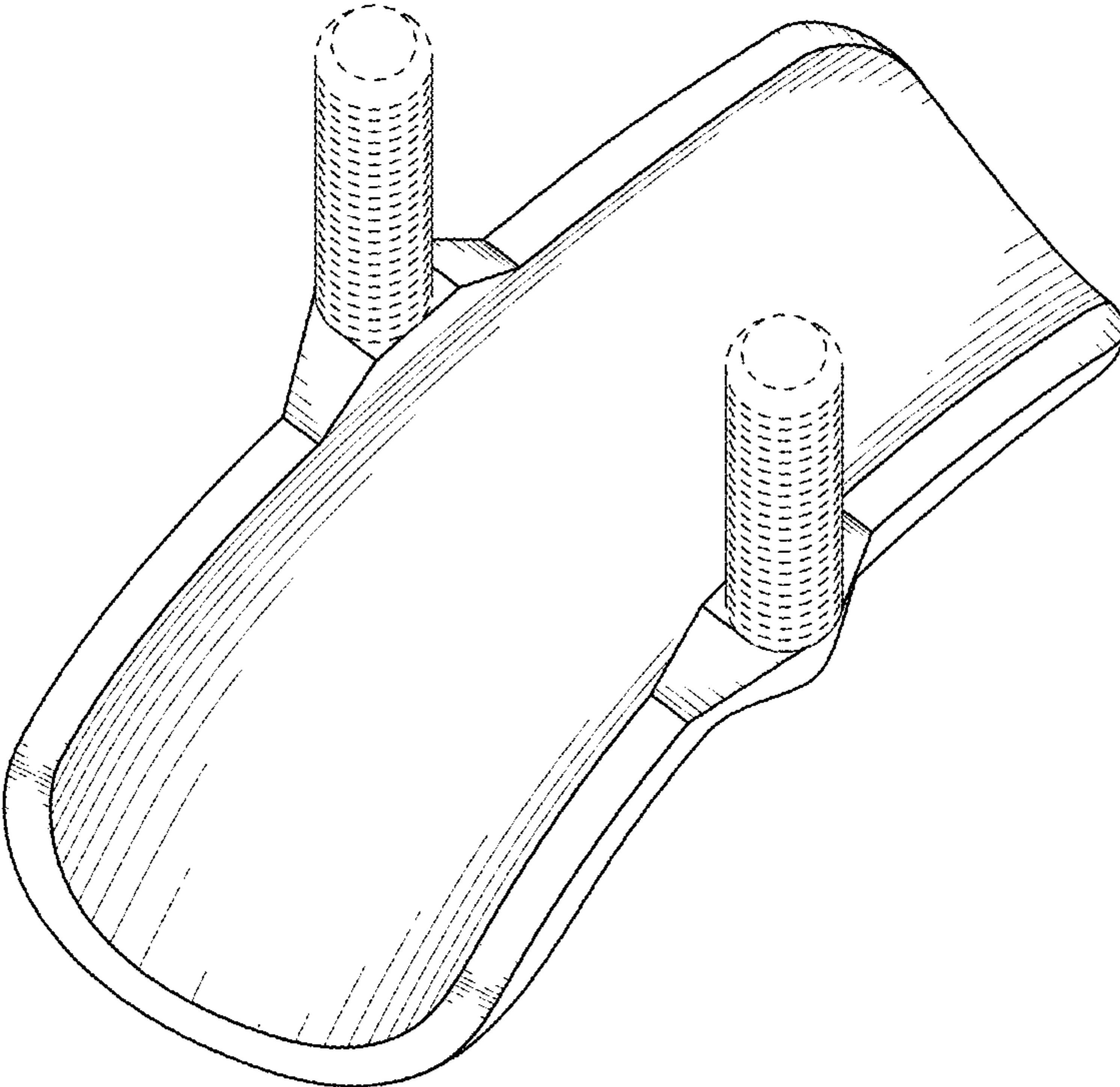

FIG. 1

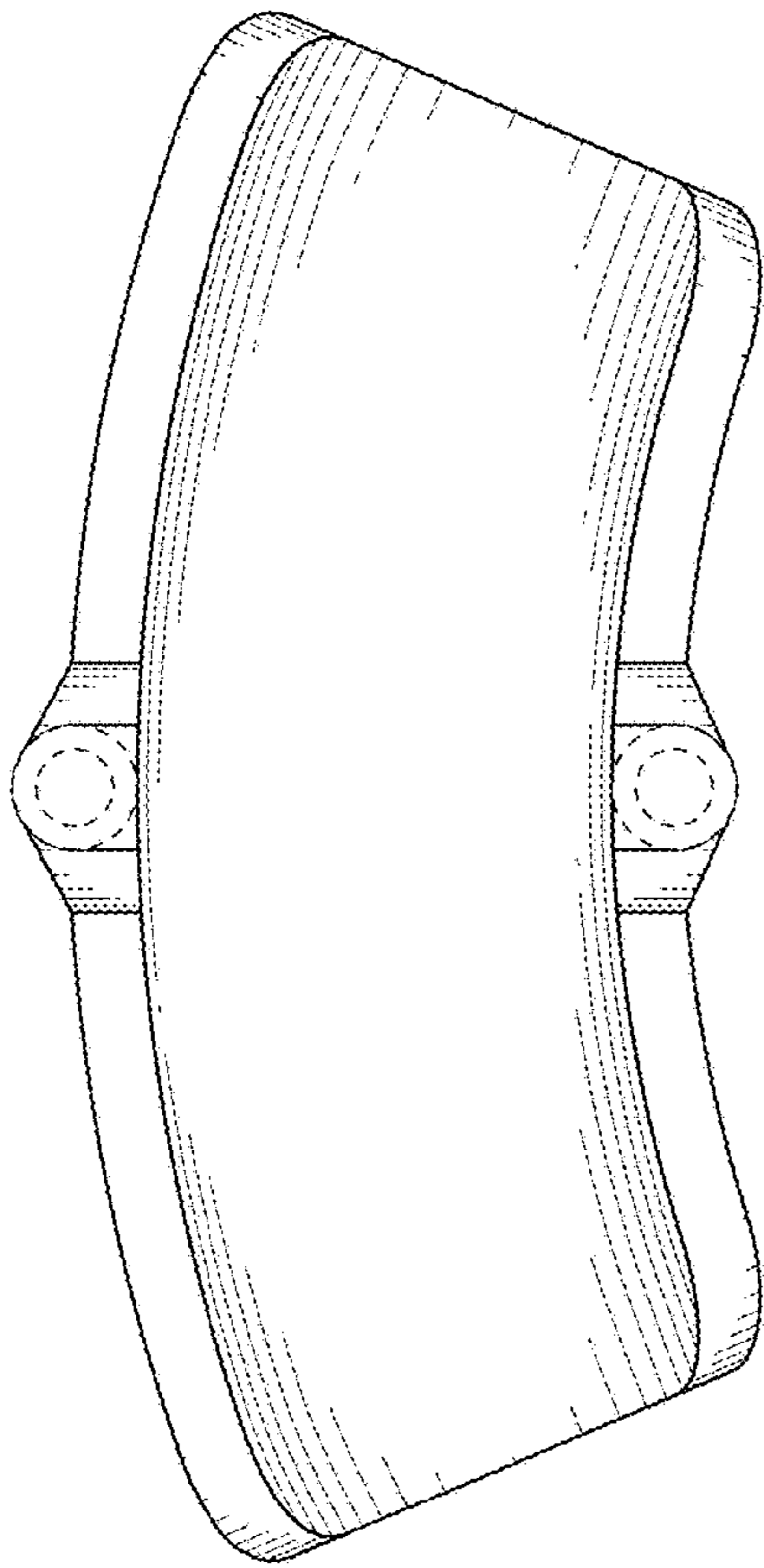

FIG. 2

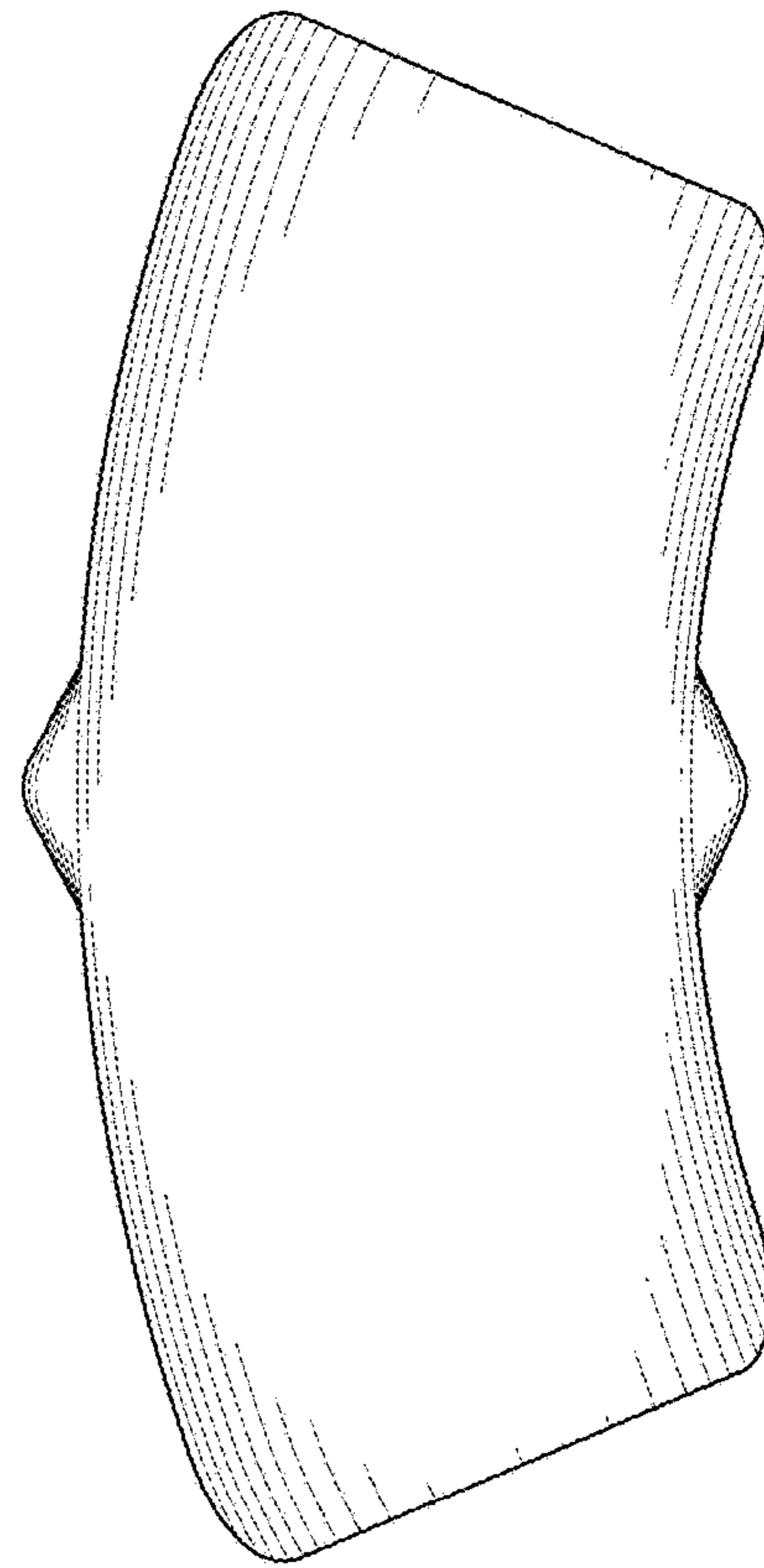

FIG. 3

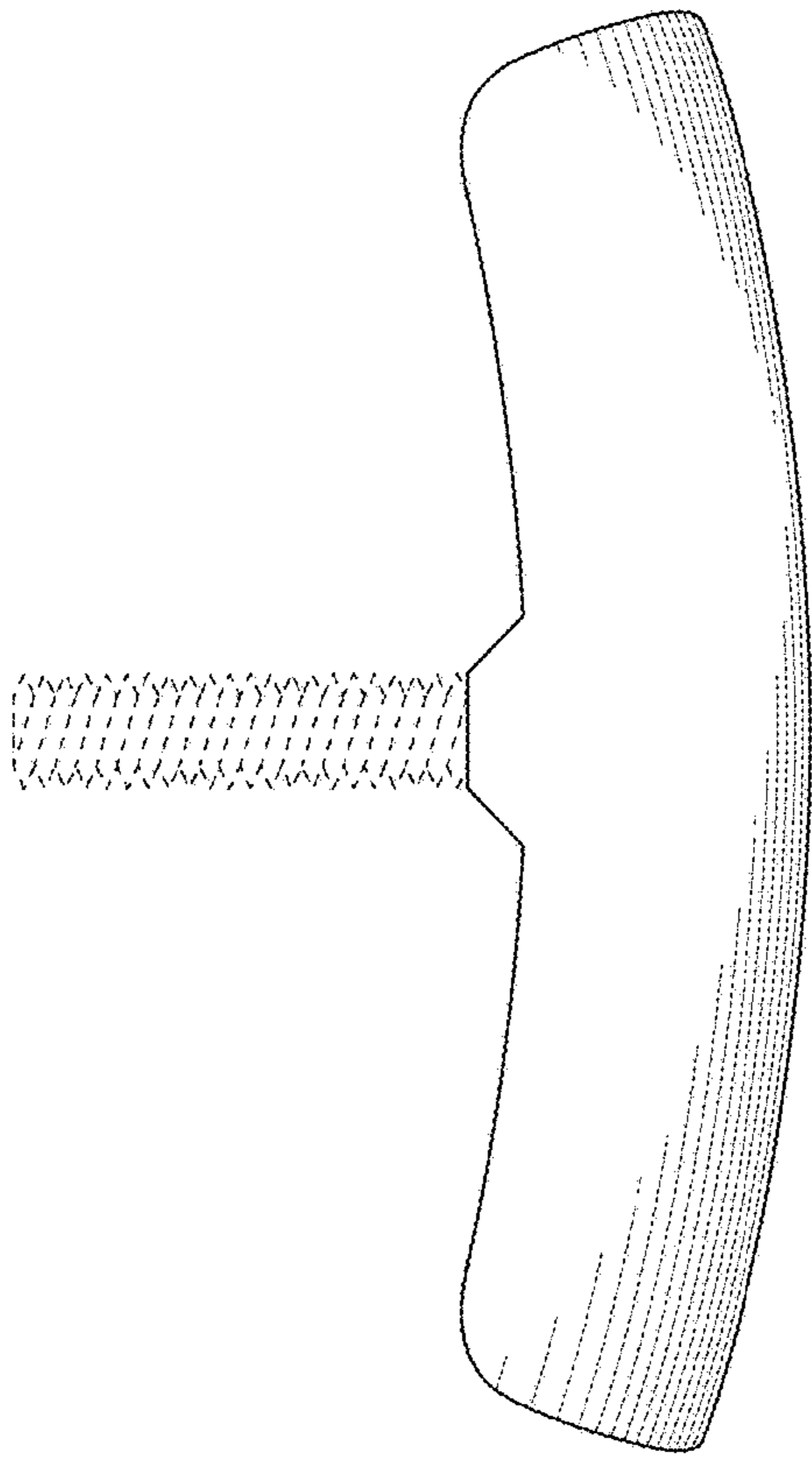

FIG. 4

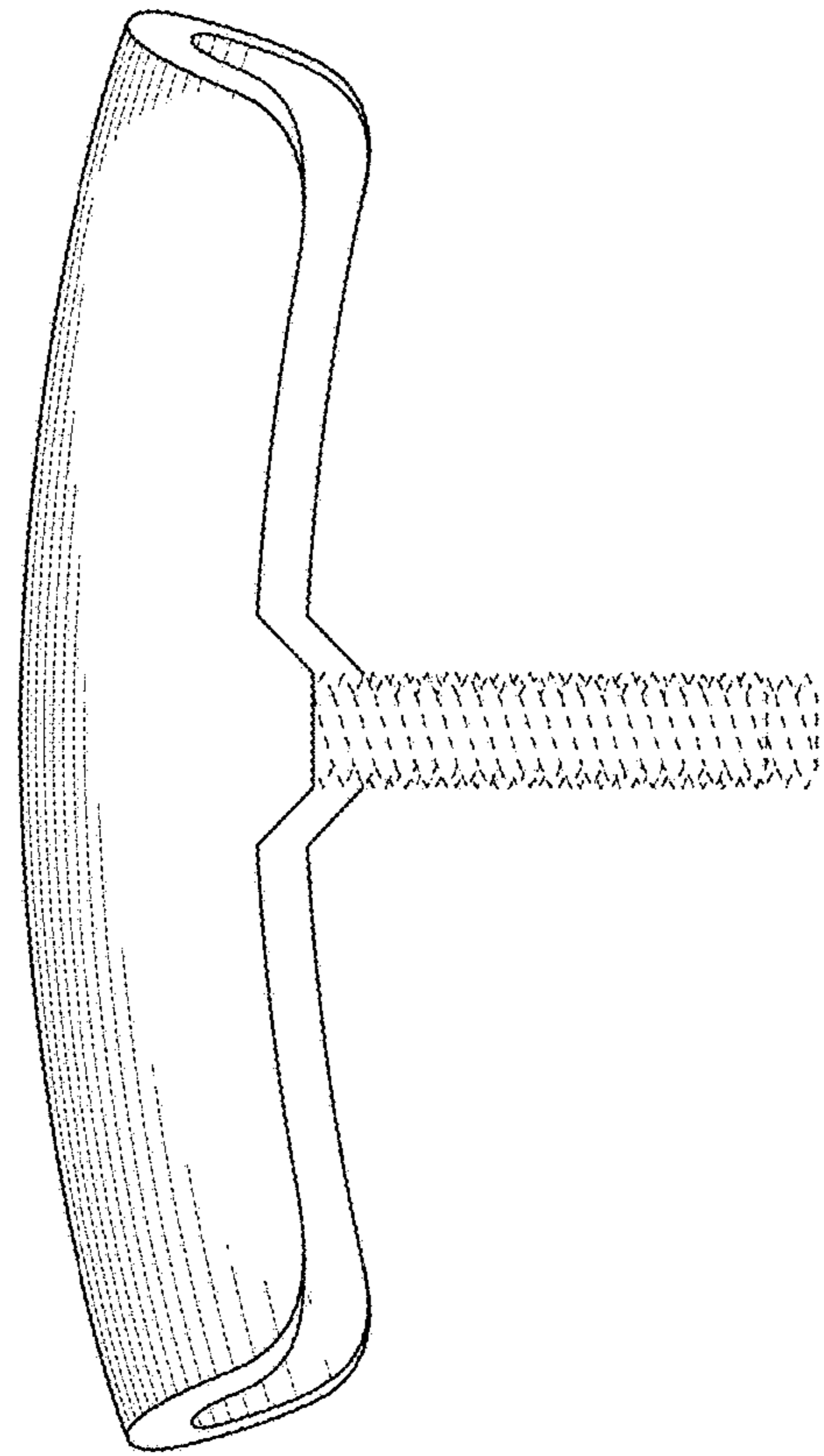

FIG. 5

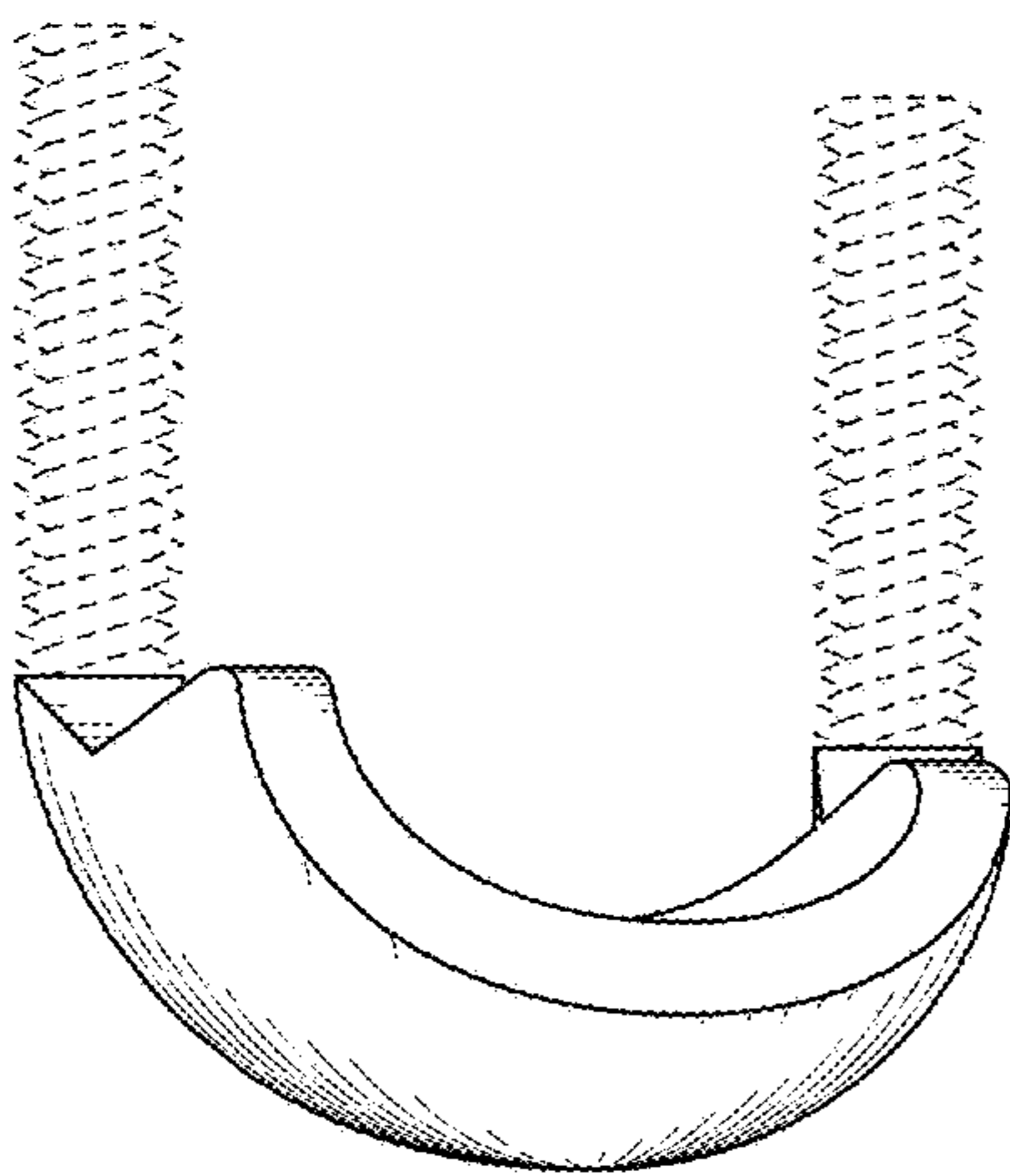

FIG. 6

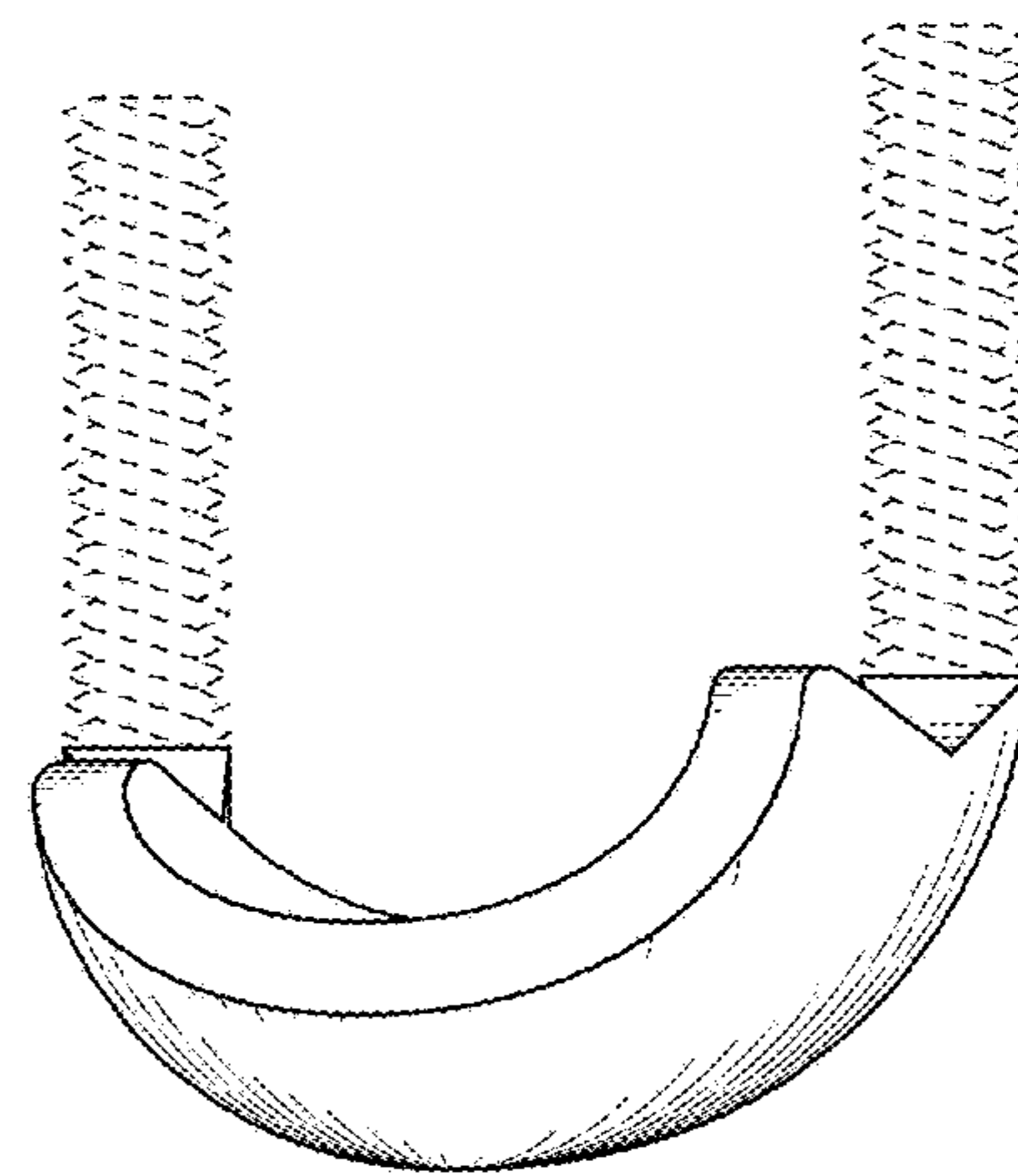

FIG. 7

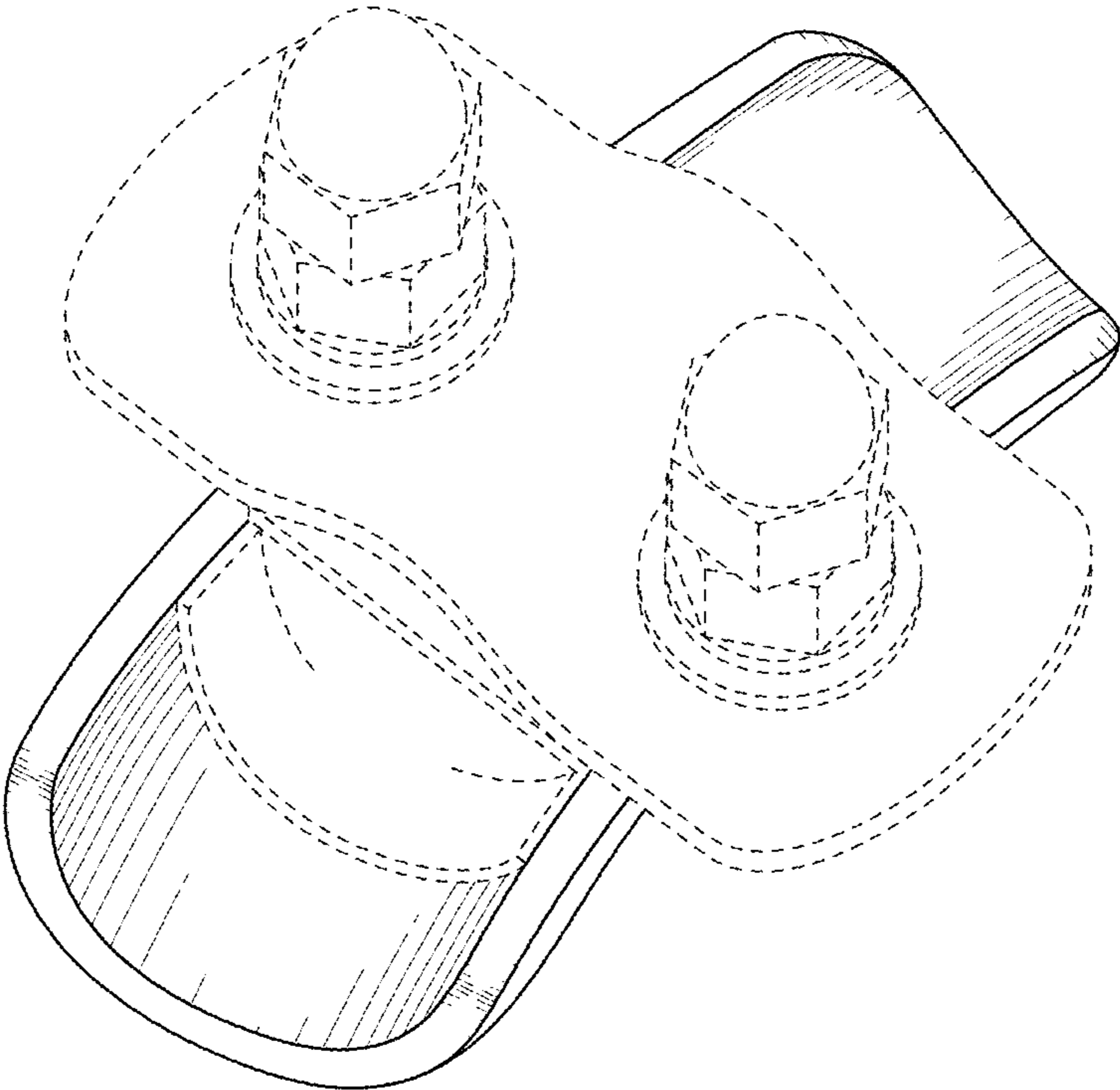

FIG. 8

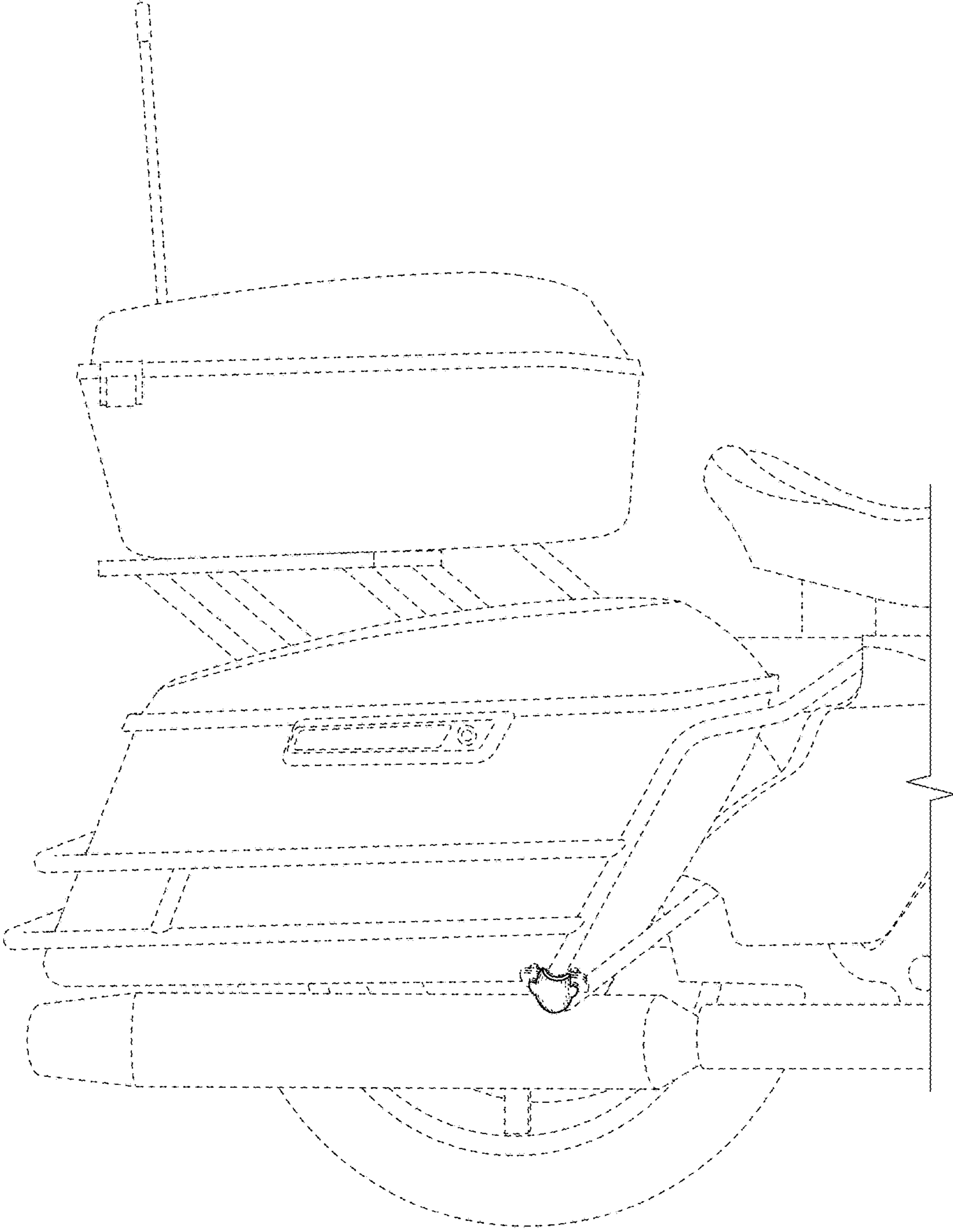

FIG. 9