



US00D780628S

(12) **United States Design Patent** (10) **Patent No.:** **US D780,628 S**
Peach et al. (45) **Date of Patent:** **** Mar. 7, 2017**

(54) **AUTO RACK RAILROAD CAR RESTRAINT
END CAP**

(56) **References Cited**

U.S. PATENT DOCUMENTS

(71) Applicant: **Standard Car Truck Company**, Park Ridge, IL (US)

1,424,957 A 8/1922 Tilburg
1,776,935 A 9/1930 Snyder
(Continued)

(72) Inventors: **Walter J. Peach**, Montgomery, IL (US); **John D. Anderson**, Oswego, IL (US); **Michael K. Burke**, Wheaton, IL (US)

FOREIGN PATENT DOCUMENTS

EP 2221215 8/2010

(73) Assignee: **Standard Car Truck Company**, Rosemont, IL (US)

OTHER PUBLICATIONS

ZefTek, A Wabtec Company, Lo-Pro™ Application/Use Advertisement, published prior to Sep. 10, 2013 (11 pages).
(Continued)

(**) Term: **15 Years**

Primary Examiner — T. Chase Nelson

Assistant Examiner — Ania Aman

(21) Appl. No.: **29/540,586**

(74) *Attorney, Agent, or Firm* — Neal, Gerber & Eisenberg LLP

(22) Filed: **Sep. 25, 2015**

Related U.S. Application Data

(57) **CLAIM**

The ornamental design for an auto rack railroad car restraint end cap, as shown and described herein.

(60) Continuation-in-part of application No. 14/596,843, filed on Jan. 14, 2015, now Pat. No. 9,321,389, which
(Continued)

DESCRIPTION

(51) **LOC (10) Cl.** **12-03**
(52) **U.S. Cl.**
USPC **D12/42**
(58) **Field of Classification Search**
USPC D12/36-52, 217; 410/20, 9, 10, 23, 30;
D8/382, 349, 383; D11/200, 218
CPC ... B61G 9/00; B61G 9/02; B61G 9/04; B61G 9/06; B61G 9/08; B61G 9/12; B61G 9/14; B61G 9/16; B60P 3/079; B60P 3/07; B60P 3/077; B60P 7/08; B60P 3/075; B60P

FIG. 1 is a perspective view of an auto rack railroad car restraint end cap of our new design.
FIG. 2 is a rear view of the auto rack railroad car restraint end cap of our new design illustrated in FIG. 1.
FIG. 3 is a front view of the auto rack railroad car restraint end cap of our design illustrated in FIG. 1.
FIG. 4 is a right side view of the auto rack railroad car restraint end cap of our new design illustrated in FIG. 1, the left side view being a mirror image thereof; and,
FIG. 5 is a top view of the auto rack railroad car restraint end cap of our new design illustrated in FIG. 1, the bottom view being a mirror image thereof.

(Continued)

1 Claim, 4 Drawing Sheets

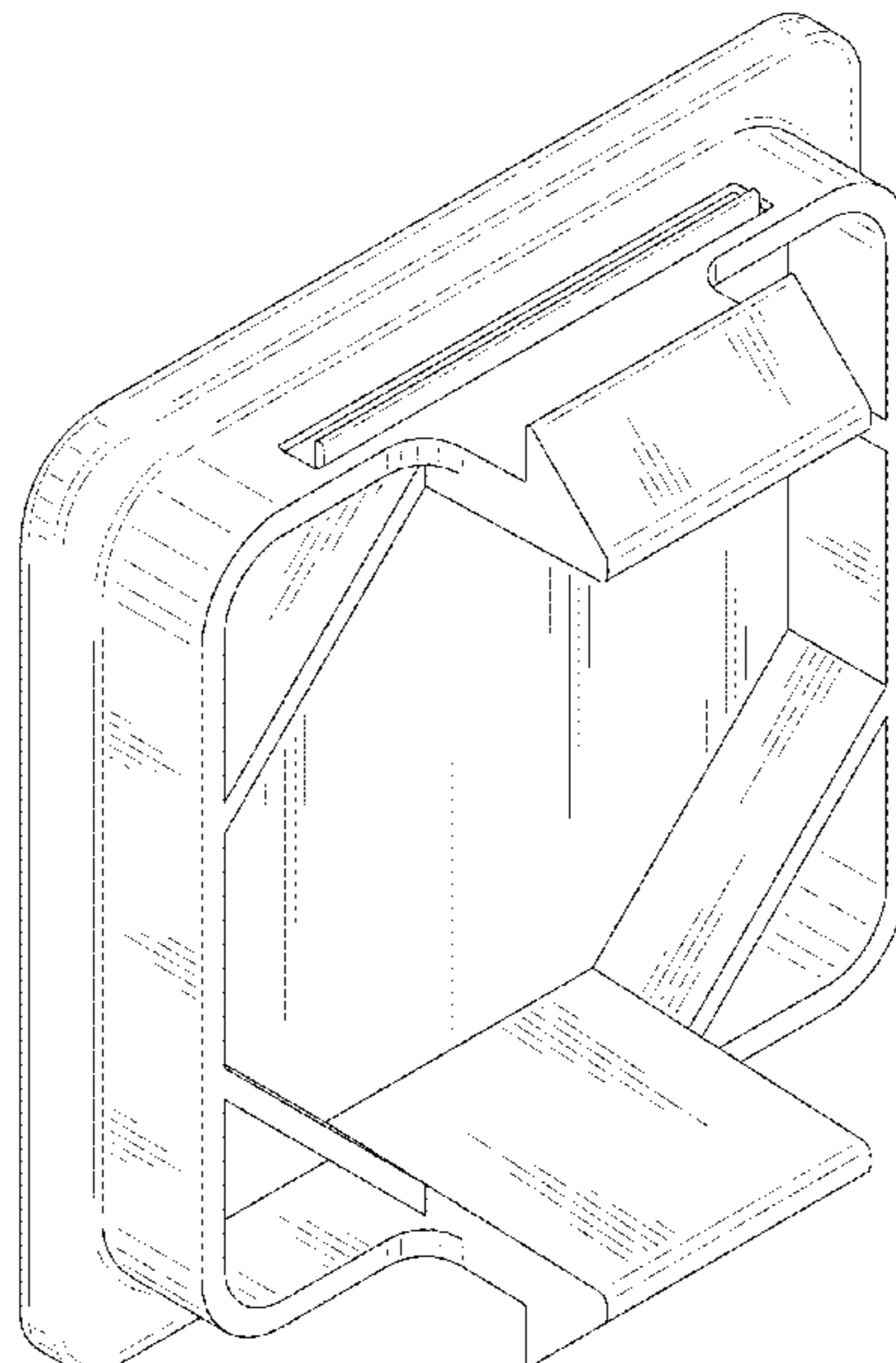

Related U.S. Application Data

is a division of application No. 14/319,147, filed on Jun. 30, 2014, now Pat. No. 8,961,084.

- (58) **Field of Classification Search**
 CPC 3/073; B60P 7/0807; B60P 7/0892; A44B 11/20; A44B 11/06; A44B 11/18; B61D 45/001; B60T 3/00
 See application file for complete search history.

(56) **References Cited**

U.S. PATENT DOCUMENTS

2,066,714	A	1/1937	Butterworth	
2,540,400	A	2/1951	McHenry	
2,705,081	A	3/1955	Jacobs	
2,730,400	A	1/1956	Francis	
2,771,162	A	11/1956	Marsh	
2,797,774	A	7/1957	Eckhart	
2,853,257	A	9/1958	Cook	
2,858,905	A	11/1958	Fahland	
2,895,569	A	7/1959	Nystrom	
3,119,350	A	1/1964	Bellingher	
3,581,846	A	6/1971	Janus	
3,605,954	A	9/1971	Wakabayashi et al.	
3,739,906	A	6/1973	Cwycyshyn et al.	
3,895,587	A	7/1975	Bell	
3,986,659	A *	10/1976	Vajtay	B65D 15/08 220/4.01
4,024,820	A	5/1977	Hlinsky et al.	
4,031,983	A	6/1977	Lentini	
4,032,167	A	6/1977	Chereda	
4,060,036	A	11/1977	Palms	
4,129,975	A *	12/1978	Gabriel	A63H 33/101 403/171
4,316,686	A	2/1982	Cottrell et al.	
4,343,401	A	8/1982	Paulyson	
4,399,893	A	8/1983	Switzer	
D281,063	S	10/1985	De Raad	
4,611,961	A	9/1986	Van Iperen et al.	
4,615,416	A	10/1986	Wilson	
4,659,266	A	4/1987	Thelen et al.	
4,668,140	A	5/1987	Blunden	
4,676,344	A	6/1987	Locicero	
4,695,087	A	9/1987	Hollrock	
4,786,223	A	11/1988	Crissy et al.	
4,804,070	A	2/1989	Bohler	
4,836,726	A	6/1989	Robertson et al.	
4,838,743	A	6/1989	Blunden et al.	
4,875,813	A	10/1989	Moyer et al.	
4,960,353	A	10/1990	Thorndyke	
4,971,492	A	11/1990	Moyer et al.	
4,979,856	A	12/1990	Blunden et al.	
5,011,347	A	4/1991	Bullock	
5,037,255	A	8/1991	Bullock et al.	
5,106,245	A	4/1992	Fritz et al.	
5,160,223	A	11/1992	Seitz	
5,302,063	A	4/1994	Winsor	
5,312,213	A	5/1994	Winsor	
5,316,421	A	5/1994	Bullock et al.	
D402,616	S	12/1998	Henry	
5,954,465	A	9/1999	Ellerbush	
D415,463	S	10/1999	Henry	
D420,640	S	2/2000	Henry	

D422,960	S	4/2000	Henry	
6,161,996	A	12/2000	Bartlett	
6,164,893	A	12/2000	Glomot et al.	
D460,681	S *	7/2002	Edwards	D8/354
D474,729	S	5/2003	Sargent	
D489,310	S	5/2004	Olson et al.	
6,835,034	B2	12/2004	Winsor	
6,851,523	B1	2/2005	Gaster	
6,926,480	B2	8/2005	Anderson et al.	
D511,734	S	11/2005	Moore et al.	
D516,268	S	2/2006	Gaster	
D543,926	S	6/2007	Kutzler	
D547,712	S	7/2007	Hartmann	
D587,183	S	2/2009	Blumenthal et al.	
7,513,725	B1 *	4/2009	Bullock	B60P 3/075 410/10
D613,231	S	4/2010	Anderson et al.	
D625,989	S *	10/2010	Mancosh	D8/382
7,824,138	B2	11/2010	Bullock	
D633,850	S	3/2011	Morin	
7,976,255	B2	7/2011	Anderson et al.	
8,096,738	B2	1/2012	Anderson et al.	
D655,667	S	3/2012	Angus et al.	
D677,203	S *	3/2013	Russell	D12/100
8,430,612	B1	4/2013	Randall	
D690,644	S	10/2013	Bowman et al.	
8,961,084	B1 *	2/2015	Anderson	B60P 3/077 410/10
2006/0275096	A1	12/2006	Boydston et al.	
2008/0003076	A1 *	1/2008	Brewster	B60P 7/0807 410/117
2008/0232918	A1	9/2008	Blanchet	
2009/0003956	A1	1/2009	Tatina	
2009/0035088	A1	2/2009	Powers et al.	
2009/0208304	A1	8/2009	Bullock et al.	
2010/0296890	A1	11/2010	Bullock	
2011/0038681	A1	2/2011	Cencer	
2013/0156524	A1	6/2013	Bullock	

OTHER PUBLICATIONS

ZefTek, A Wabtec Company, Sta-Put w/Strap Application/Use Advertisement, published prior to Sep. 10, 2013 (12 pages).
 ZefTek, A Wabtec Company, Sta-Put Application/Use Advertisement, published prior to Sep. 10, 2013, (11 pages).
 Damage Prevention Newsletter, Holland's New Tri-Level Chock published prior to Sep. 10, 2013 (2 pages).
 Thrall Steel Anchor and Active Chocks with Riser, commercially available before Sep. 10, 2013 (9 pictures).
 Thrall Polymer Anchor and Active Chocks with Riser, commercially available before Sep. 10, 2013 (10 pictures).
 PCT Notification of Transmittal of the International Search Report and Written Opinion of the International Searching Authority for International Application No. PCT/US2014/021017 dated Jun. 20, 2014.
 Pictures of Commercially Available Plastic Cap for Chock (Part No. ZT-717), Sold and Publicly Distributed Prior to Sep. 25, 2014.
 Pictures of Commercially Available Rubber Cap for Chock (Part No. ZT-717), Sold and Publicly Distributed Prior to Sep. 25, 2014.
 International Search Report and the Written Opinion dated Feb. 25, 2015, for International Application No. PCT/US2014/065602, filed Nov. 14, 2014.

* cited by examiner

FIG. 1

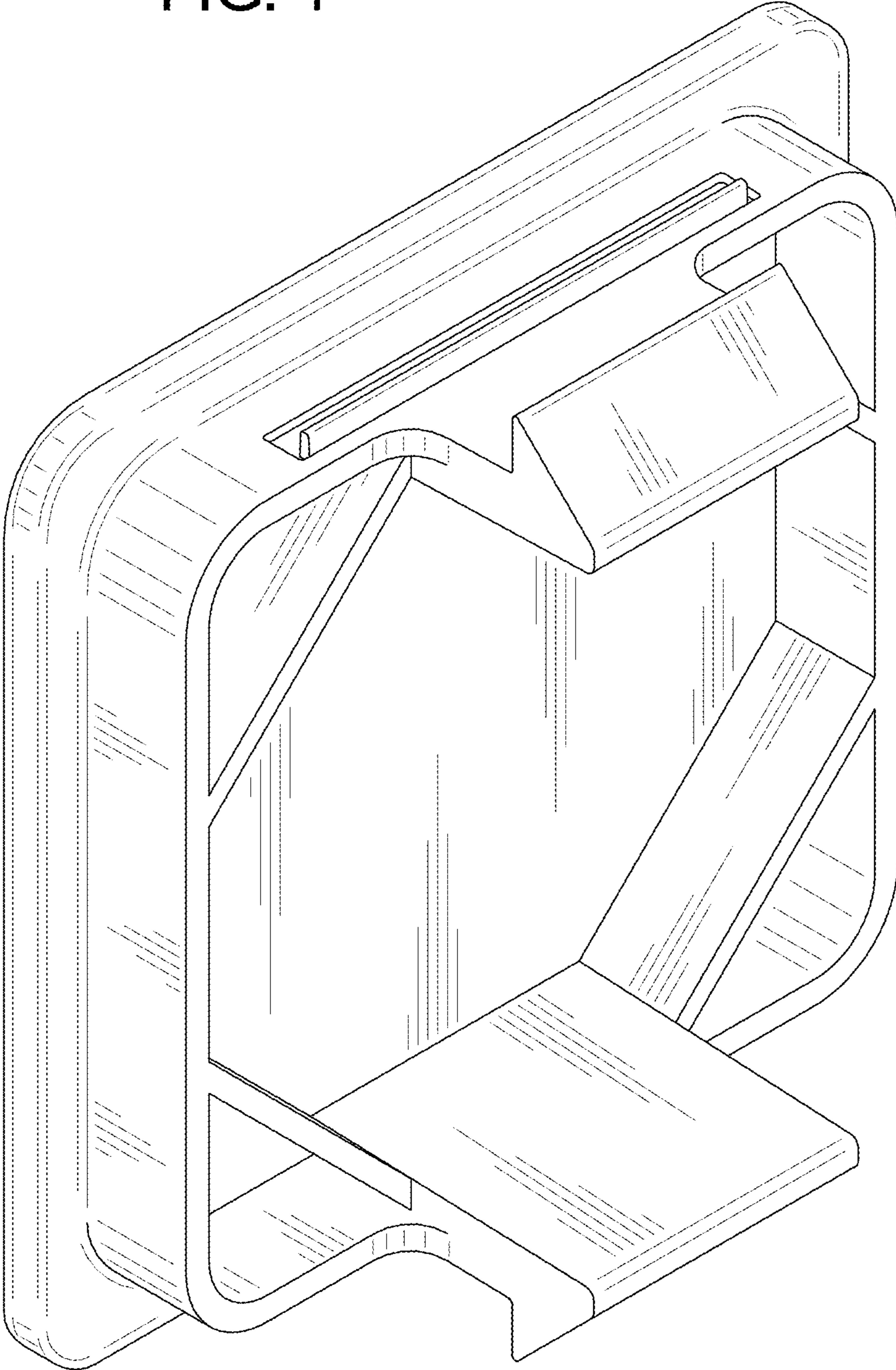

FIG. 2

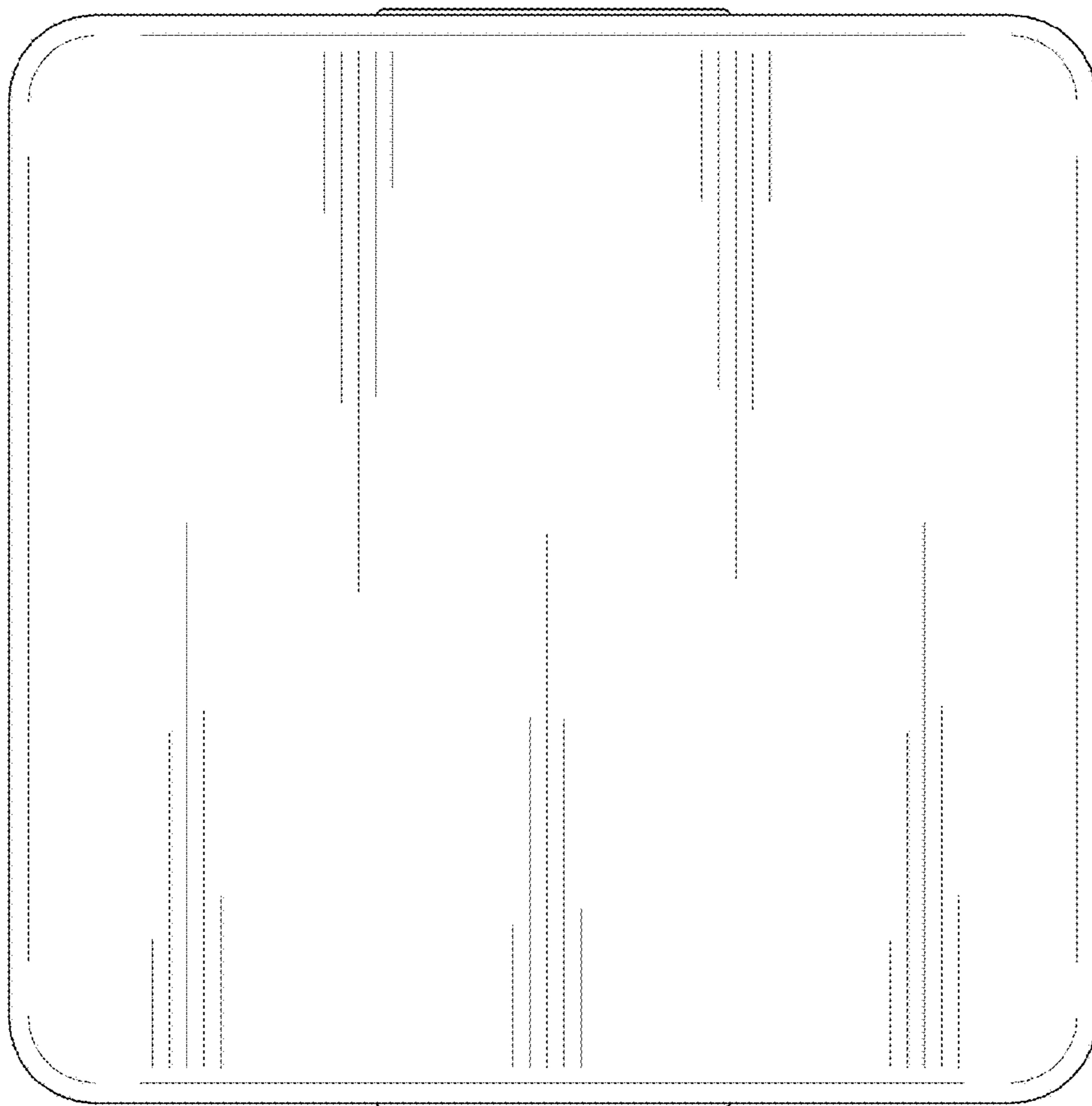

FIG. 3

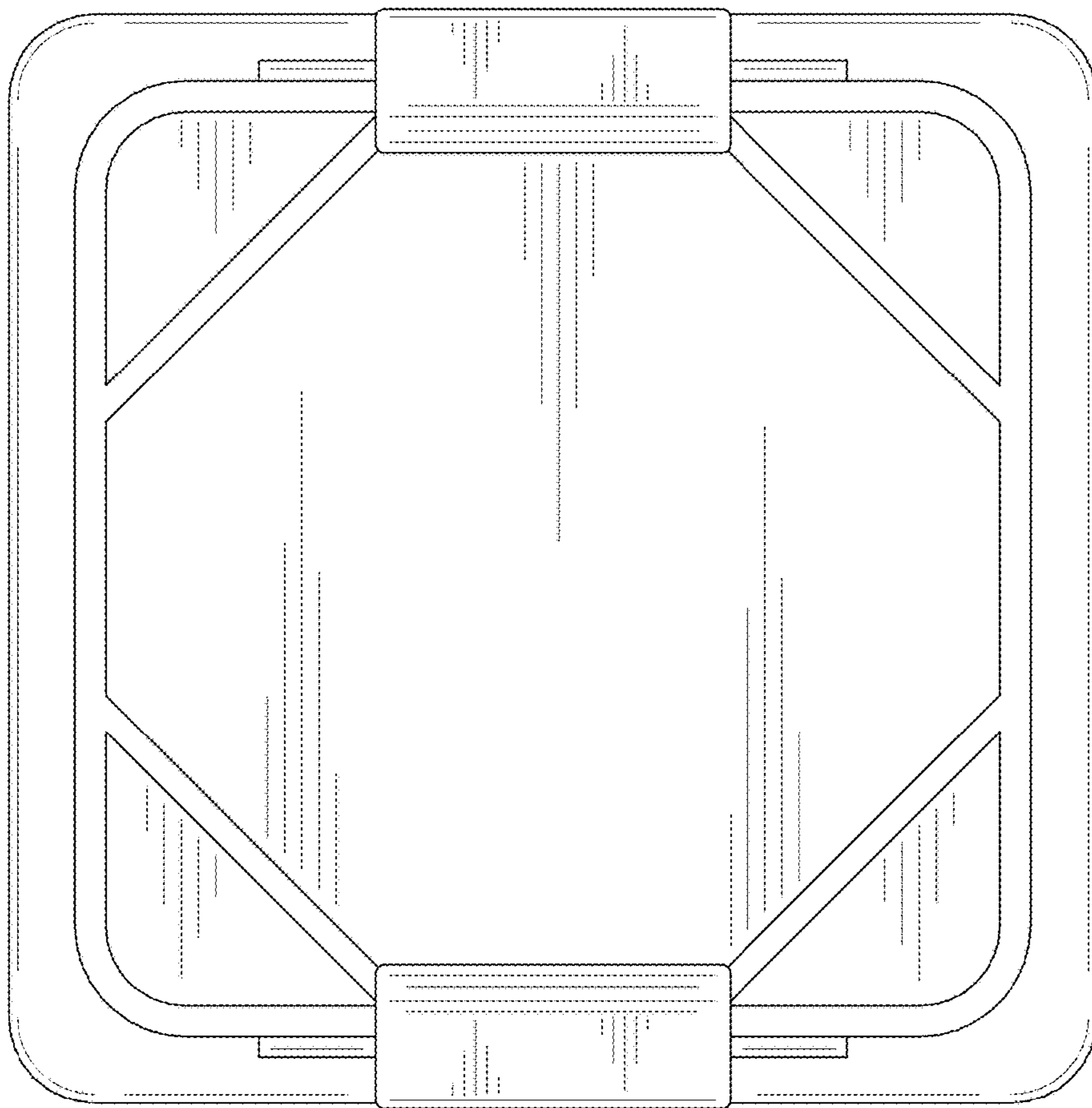

FIG. 4

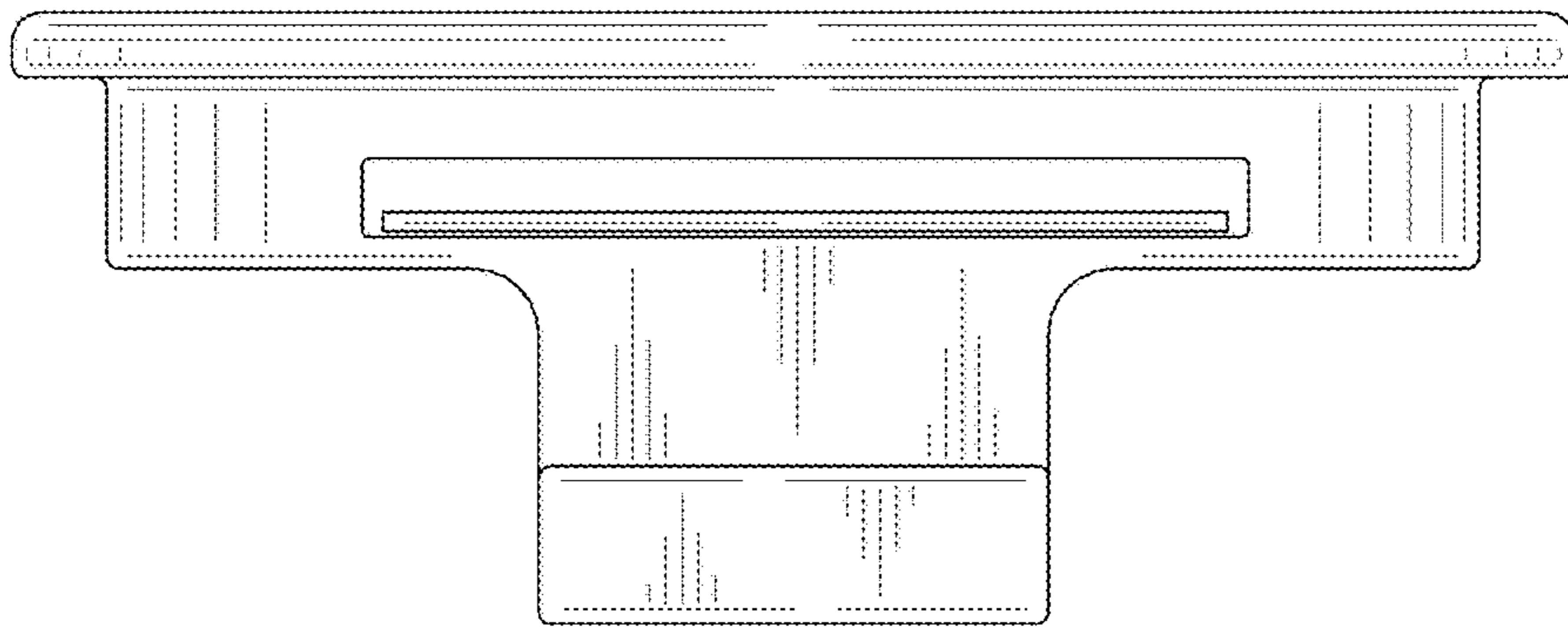

FIG. 5

