



US00D780233S

(12) **United States Design Patent** (10) **Patent No.:** **US D780,233 S**
Saari et al. (45) **Date of Patent:** **** Feb. 28, 2017**

(54) **CAB FOR VEHICLE**
(71) Applicant: **SANDVIK MINING AND CONSTRUCTION OY**, Tampere (FI)
(72) Inventors: **Jaakko Saari**, Tampere (FI); **Oki Ahokas**, Tampere (FI); **Jarmo Rantanen**, Julkujarvi (FI)
(73) Assignee: **SANDVIK MINING AND CONSTRUCTION OY**, Tampere (FI)
(**) Term: **15 Years**
(21) Appl. No.: **29/547,420**
(22) Filed: **Dec. 3, 2015**
(51) **LOC (10) Cl.** **15-03**
(52) **U.S. Cl.**
USPC **D15/30**
(58) **Field of Classification Search**
USPC D15/28, 30, 31, 22-26; D34/37; 180/89.11, 180/89.12, 89.13, 89.19, 900
CPC B66C 13/54; E02F 9/16; E02F 9/163; E02F 9/06; B62D 33/0617; B62D 49/00-49/085; B62D 33/06-33/073; B60J 7/00; B60J 1/004; B60J 1/02; B60J 1/04; B60J 5/0487
See application file for complete search history.

(56) **References Cited**
U.S. PATENT DOCUMENTS
4,082,343 A * 4/1978 Hurt, II B62D 33/0604 180/89.12
D267,648 S * 1/1983 Baconet D15/30
D438,878 S * 3/2001 Brandenburg, III D15/30

D446,225 S * 8/2001 Brandenburg, III D15/30
D453,023 S * 1/2002 Kaneko D15/21
D455,763 S * 4/2002 Brandenburg, III D15/28
D637,630 S * 5/2011 Yamamoto D15/30
D642,205 S * 7/2011 Yamamoto D15/30
D660,880 S * 5/2012 Laugurette D15/30
D660,881 S * 5/2012 Bohme D15/30
D671,566 S * 11/2012 Fang D15/30
D678,360 S * 3/2013 Kozai D15/30
D684,607 S * 6/2013 Hagura D15/30
D687,868 S * 8/2013 Watson D15/30
D720,370 S * 12/2014 Carter D15/30
D725,156 S * 3/2015 Saari D15/21
D726,780 S * 4/2015 Saari D15/21
D733,192 S * 6/2015 Saari D15/21
D749,148 S * 2/2016 Darekar D15/30
D751,123 S * 3/2016 Kazakoff D15/30
D762,248 S * 7/2016 Steinhardt D15/30
2009/0026803 A1 * 1/2009 Yano B60J 1/04 296/190.1

* cited by examiner
Primary Examiner — Mark Goodwin
(74) *Attorney, Agent, or Firm* — Corinne R. Gorski

(57) **CLAIM**
The ornamental design for a cab for vehicle, as shown and described.

DESCRIPTION
FIG. 1 is a front perspective view of a cab for vehicle;
FIG. 2 is a rear perspective view thereof;
FIG. 3 is a side view thereof;
FIG. 4 is an opposite side view thereof;
FIG. 5 is a front view thereof;
FIG. 6 is a rear view thereof; and,
FIG. 7 is a top view thereof.

1 Claim, 7 Drawing Sheets

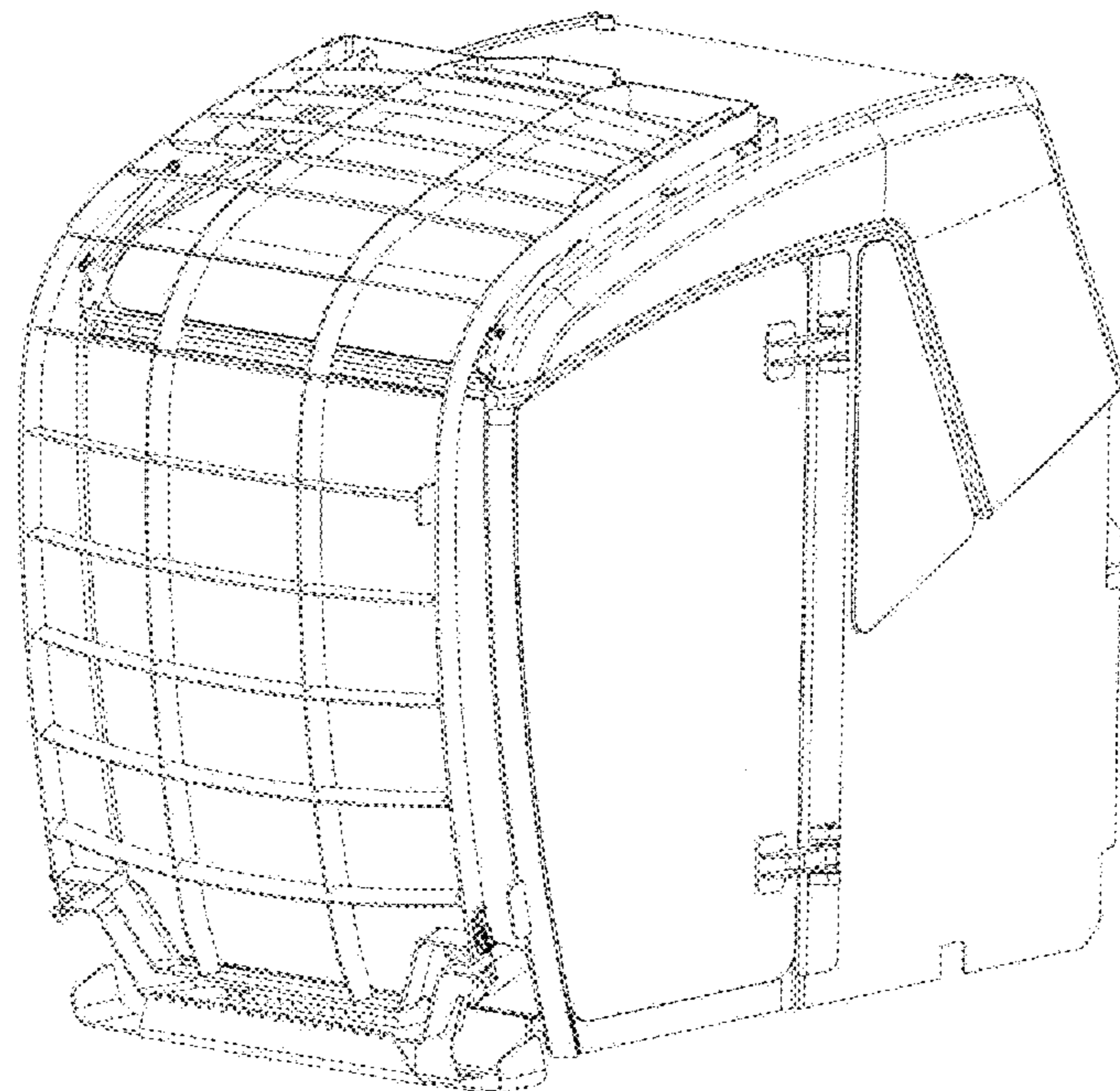

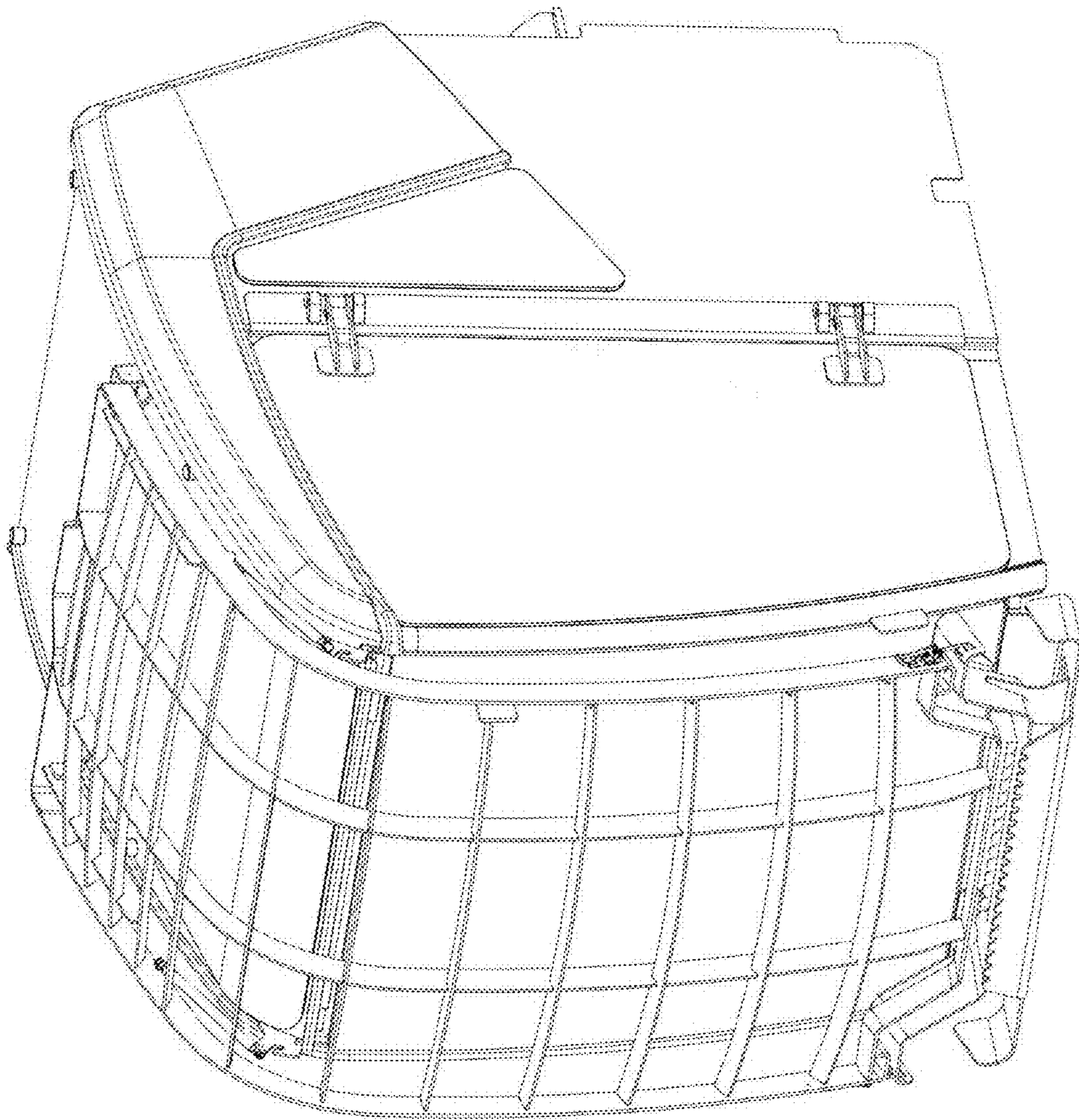

Fig. 1

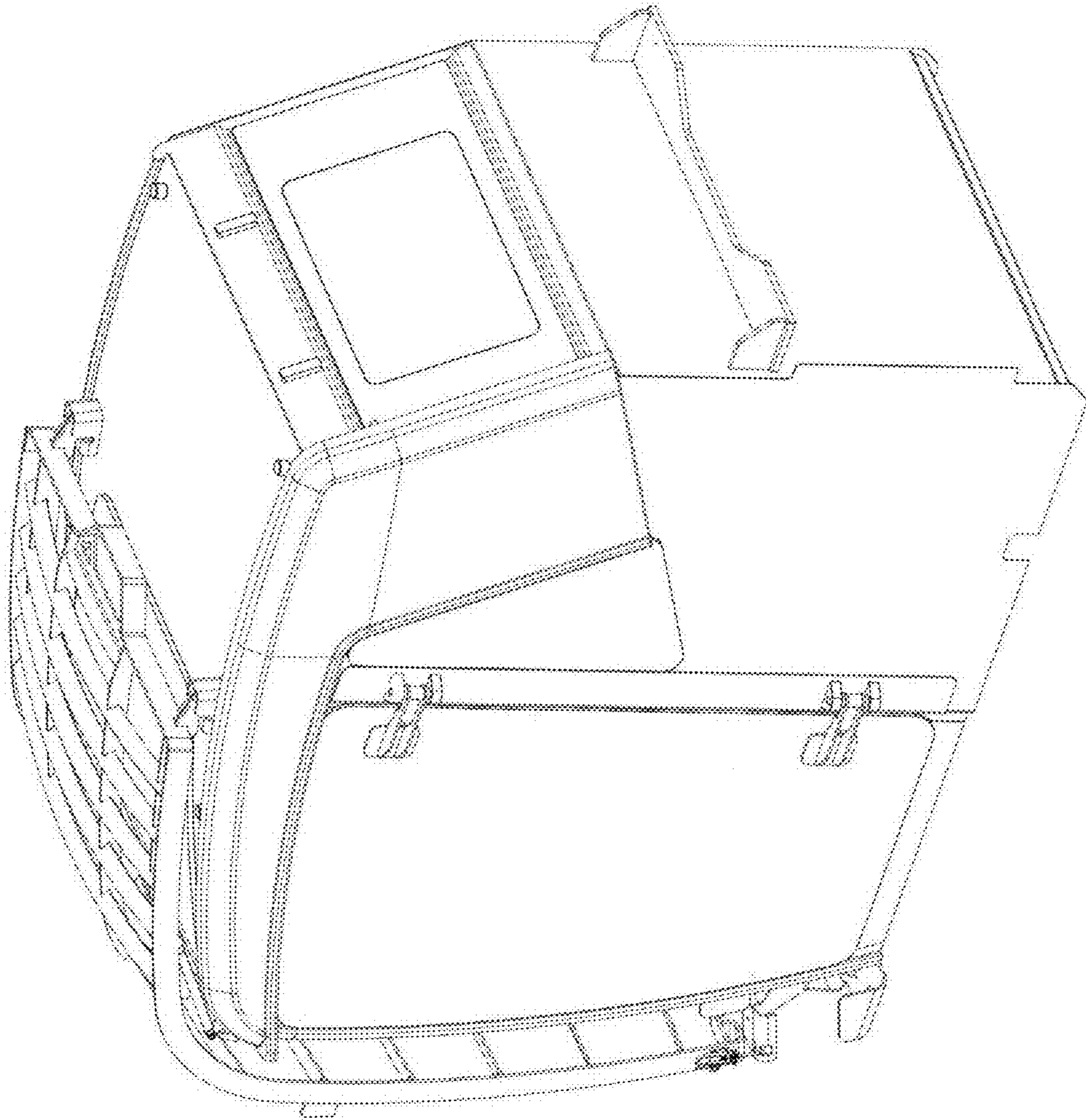

Fig. 2

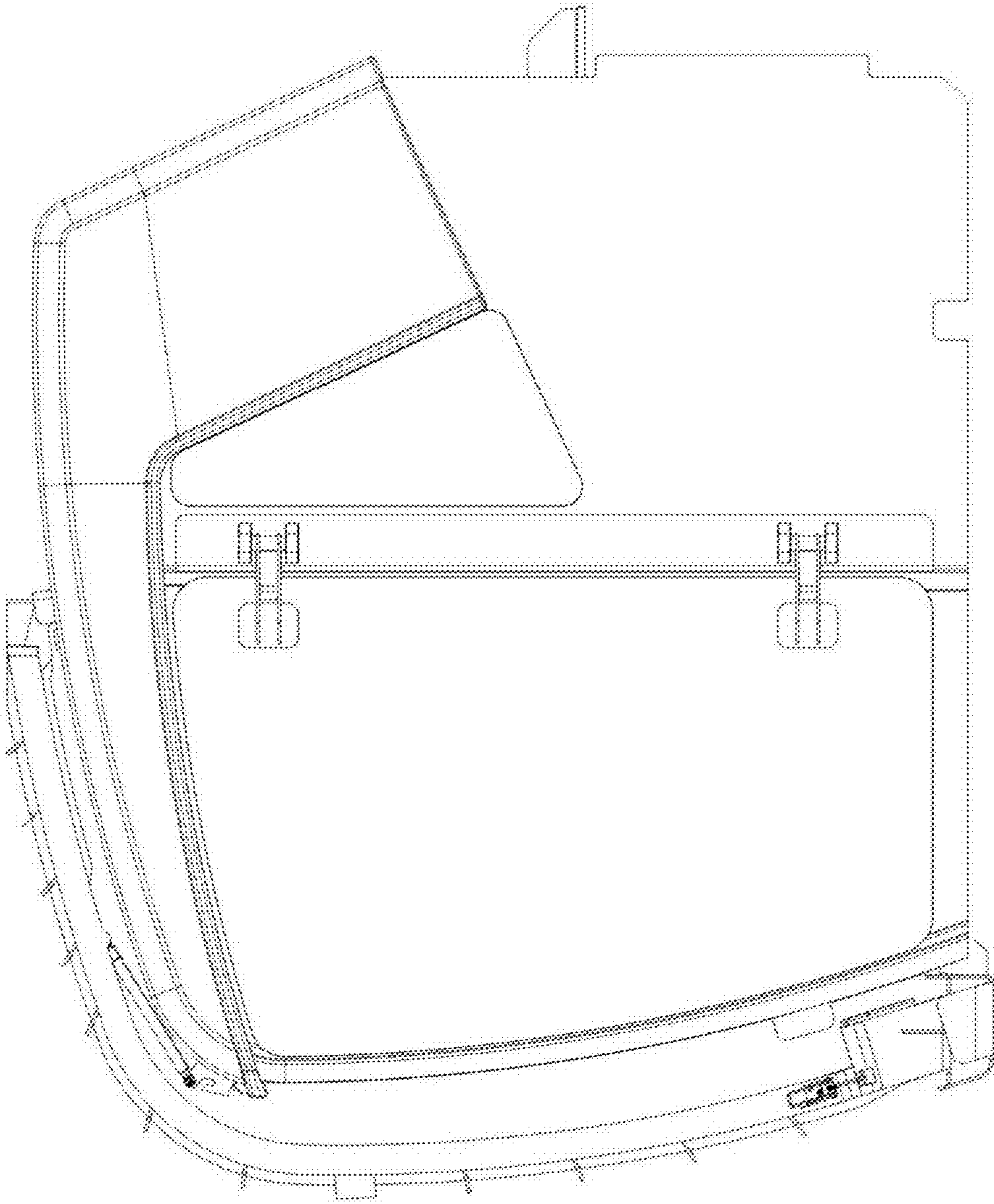

Fig. 3

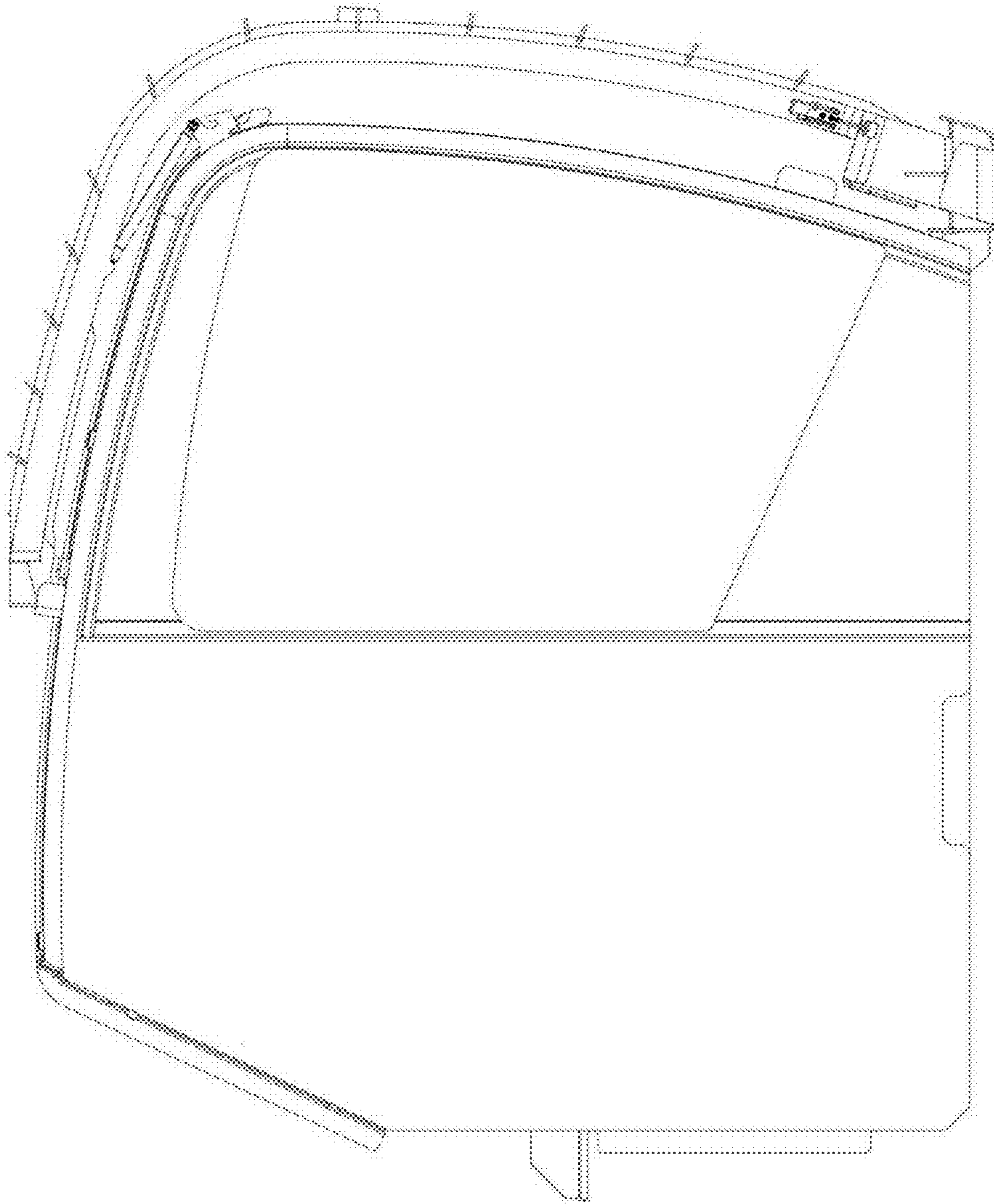

Fig.4

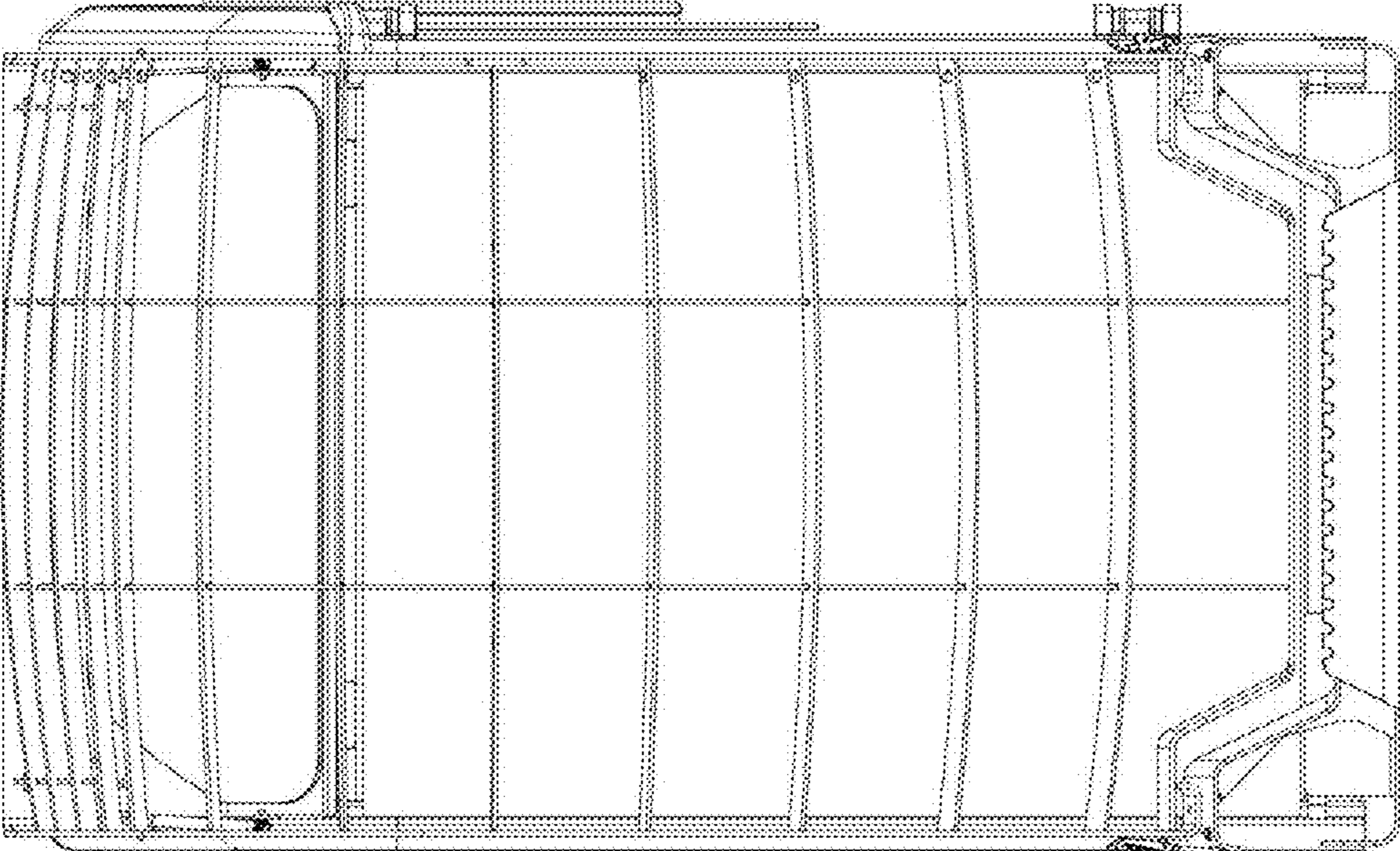

Fig. 5

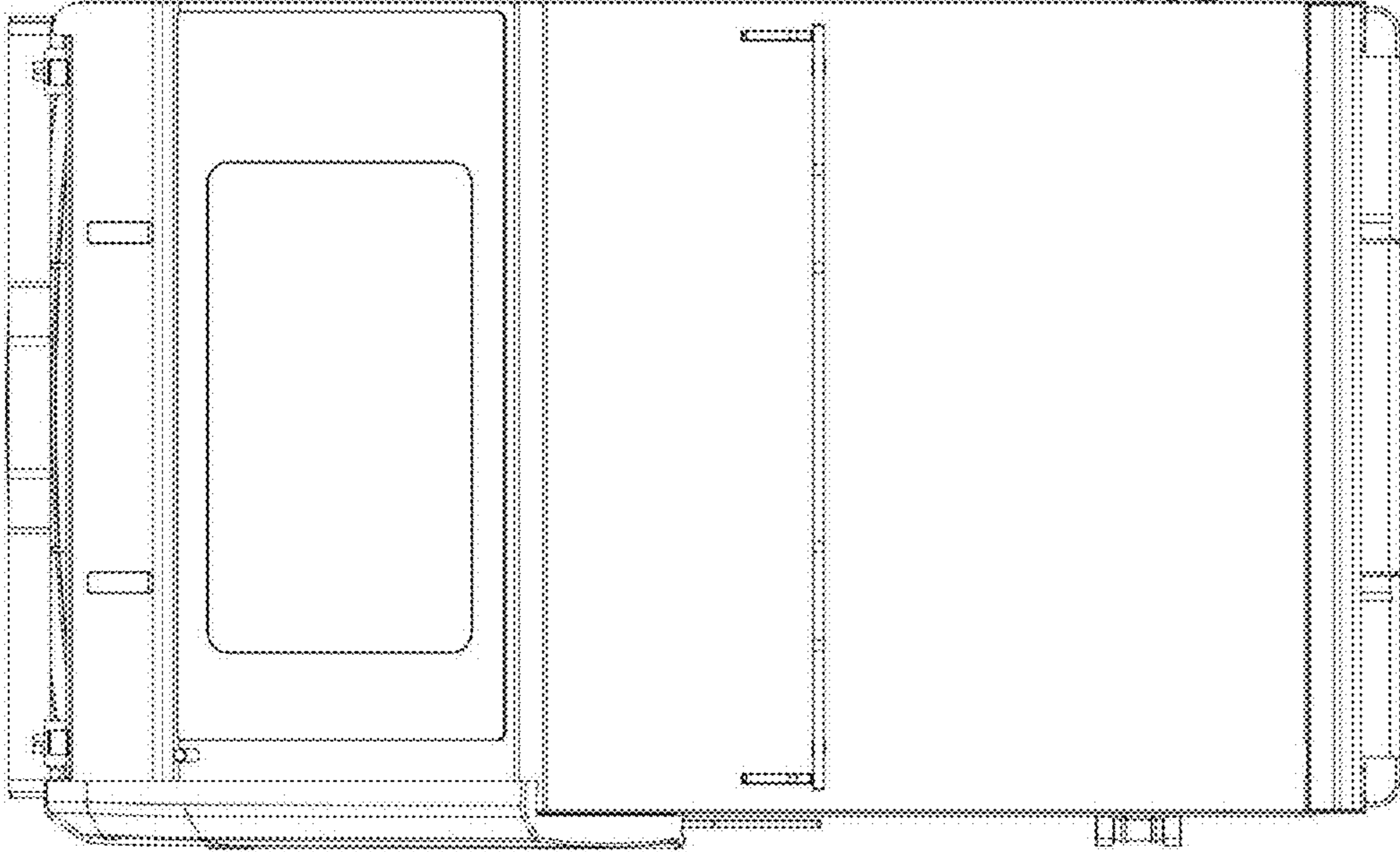

Fig. 6

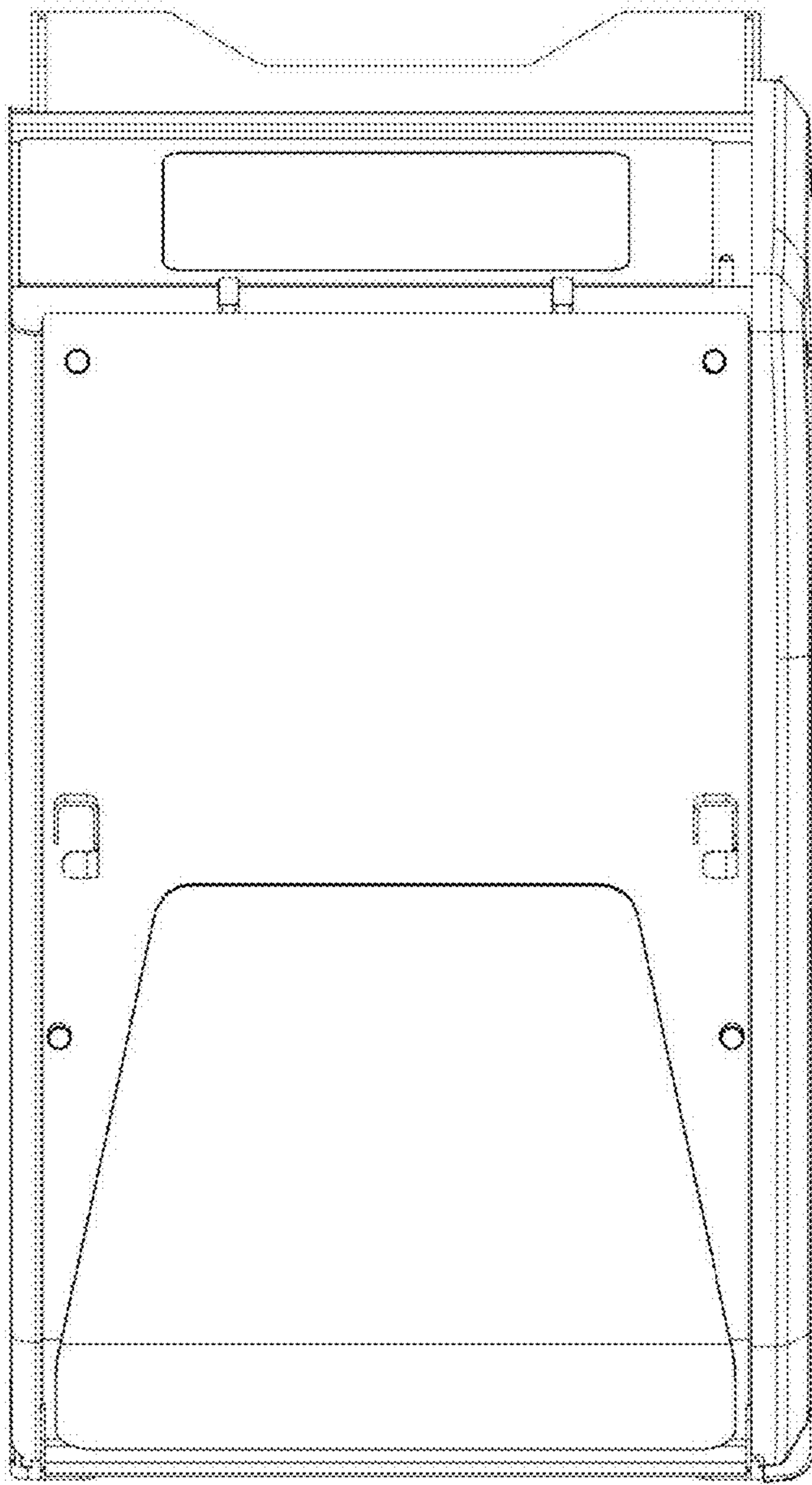

Fig. 7