



US00D780231S

(12) **United States Design Patent**  
**Saari et al.**

(10) **Patent No.:** **US D780,231 S**

(45) **Date of Patent:** **\*\* Feb. 28, 2017**

(54) **CAB FOR VEHICLE**

(71) Applicant: **SANDVIK MINING AND CONSTRUCTION OY**, Tampere (FI)

(72) Inventors: **Jaakko Saari**, Tampere (FI); **Oki Ahokas**, Tampere (FI); **Jarmo Rantanen**, Julkujarvi (FI)

(73) Assignee: **SANDVIK MINING AND CONSTRUCTION OY**, Tampere, FL (US)

(\*\*) Term: **15 Years**

(21) Appl. No.: **29/547,413**

(22) Filed: **Dec. 3, 2015**

(51) **LOC (10) Cl.** ..... **15-03**

(52) **U.S. Cl.**  
USPC ..... **D15/30**

(58) **Field of Classification Search**  
USPC D15/28, 30, 31, 22-26; D34/37; 180/89.11, 180/89.12, 89.13, 89.19, 900  
CPC ..... B66C 13/54; E02F 9/16; E02F 9/163; E02F 9/06; B62D 33/0617; B62D 49/00-49/085; B62D 33/06-33/073; B60J 7/00; B60J 1/004; B60J 1/02; B60J 1/04; B60J 5/0487

See application file for complete search history.

(56) **References Cited**

**U.S. PATENT DOCUMENTS**

- 4,082,343 A \* 4/1978 Hurt, II ..... B62D 33/0604 180/89.12
- D267,648 S \* 1/1983 Baconet ..... D15/30
- D438,878 S \* 3/2001 Brandenburg, III ..... D15/30

- D446,225 S \* 8/2001 Brandenburg, III ..... D15/30
- D453,023 S \* 1/2002 Kaneko ..... D15/21
- D455,763 S \* 4/2002 Brandenburg, III ..... D15/28
- D637,630 S \* 5/2011 Yamamoto ..... D15/30
- D642,205 S \* 7/2011 Yamamoto ..... D15/30
- D660,880 S \* 5/2012 Laugrette ..... D15/30
- D660,881 S \* 5/2012 Bohme ..... D15/30
- D671,566 S \* 11/2012 Fang ..... D15/30
- D678,360 S \* 3/2013 Kozai ..... D15/30
- D684,607 S \* 6/2013 Hagura ..... D15/30
- D687,868 S \* 8/2013 Watson ..... D15/30
- D720,370 S \* 12/2014 Carter ..... D15/30
- D725,156 S \* 3/2015 Saari ..... D15/21
- D726,780 S \* 4/2015 Saari ..... D15/21
- D733,192 S \* 6/2015 Saari ..... D15/21
- D749,148 S \* 2/2016 Darekar ..... D15/30
- D751,123 S \* 3/2016 Kazakoff ..... D15/30
- D762,248 S \* 7/2016 Steinhardt ..... D15/30
- 2009/0026803 A1 \* 1/2009 Yano ..... B60J 1/04 296/190.1

\* cited by examiner

*Primary Examiner* — Mark Goodwin

(74) *Attorney, Agent, or Firm* — Corinne R. Gorski

(57) **CLAIM**

The ornamental design for a cab for vehicle, as shown and described.

**DESCRIPTION**

FIG. 1 is a front perspective view of a cab for vehicle; FIG. 2 is a rear perspective view thereof; FIG. 3 is a side view thereof; FIG. 4 is an opposite side view thereof; FIG. 5 is a front view thereof; FIG. 6 is a rear view thereof; and, FIG. 7 is a top view thereof.

**1 Claim, 7 Drawing Sheets**

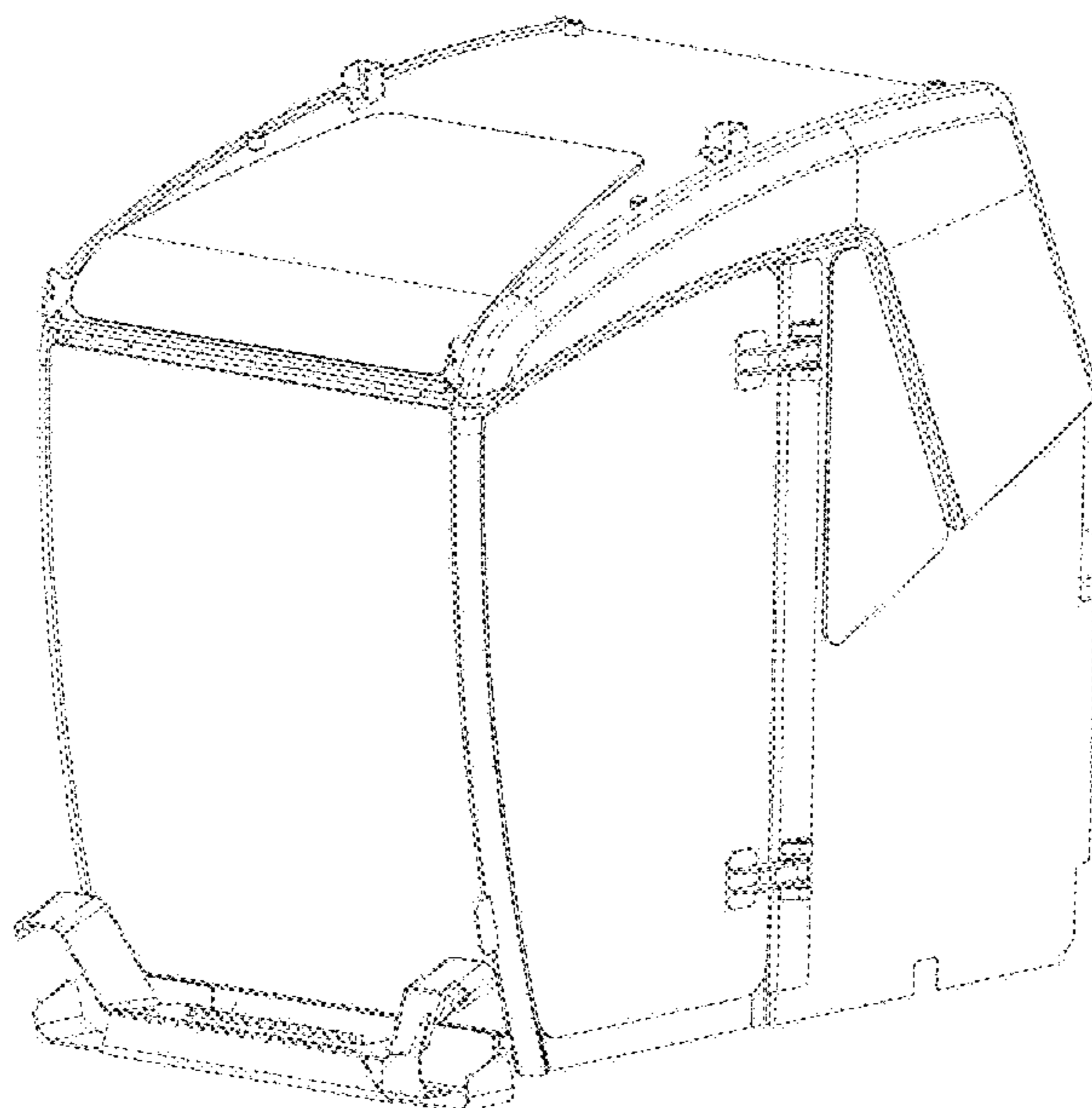

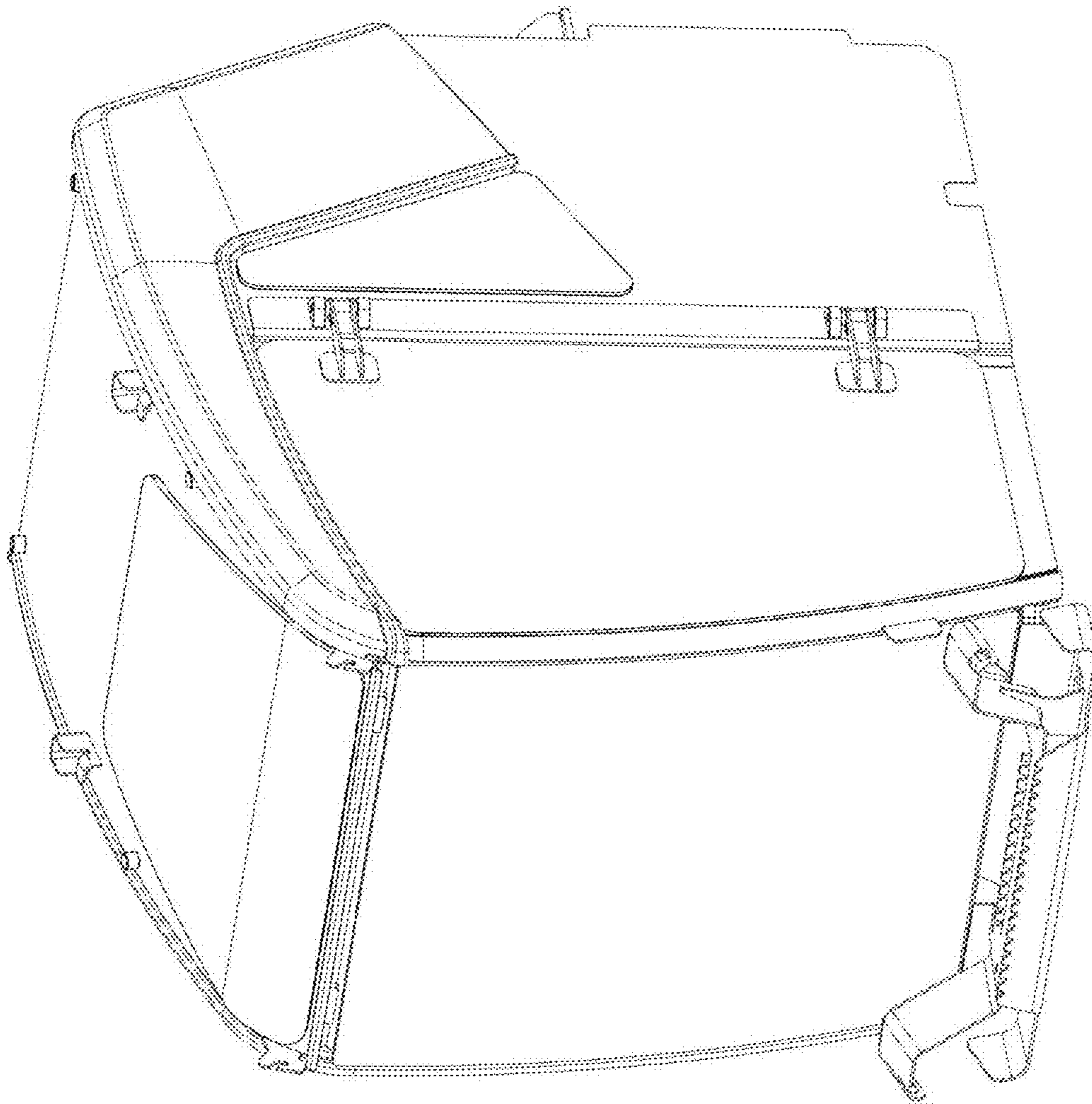

Fig. 1

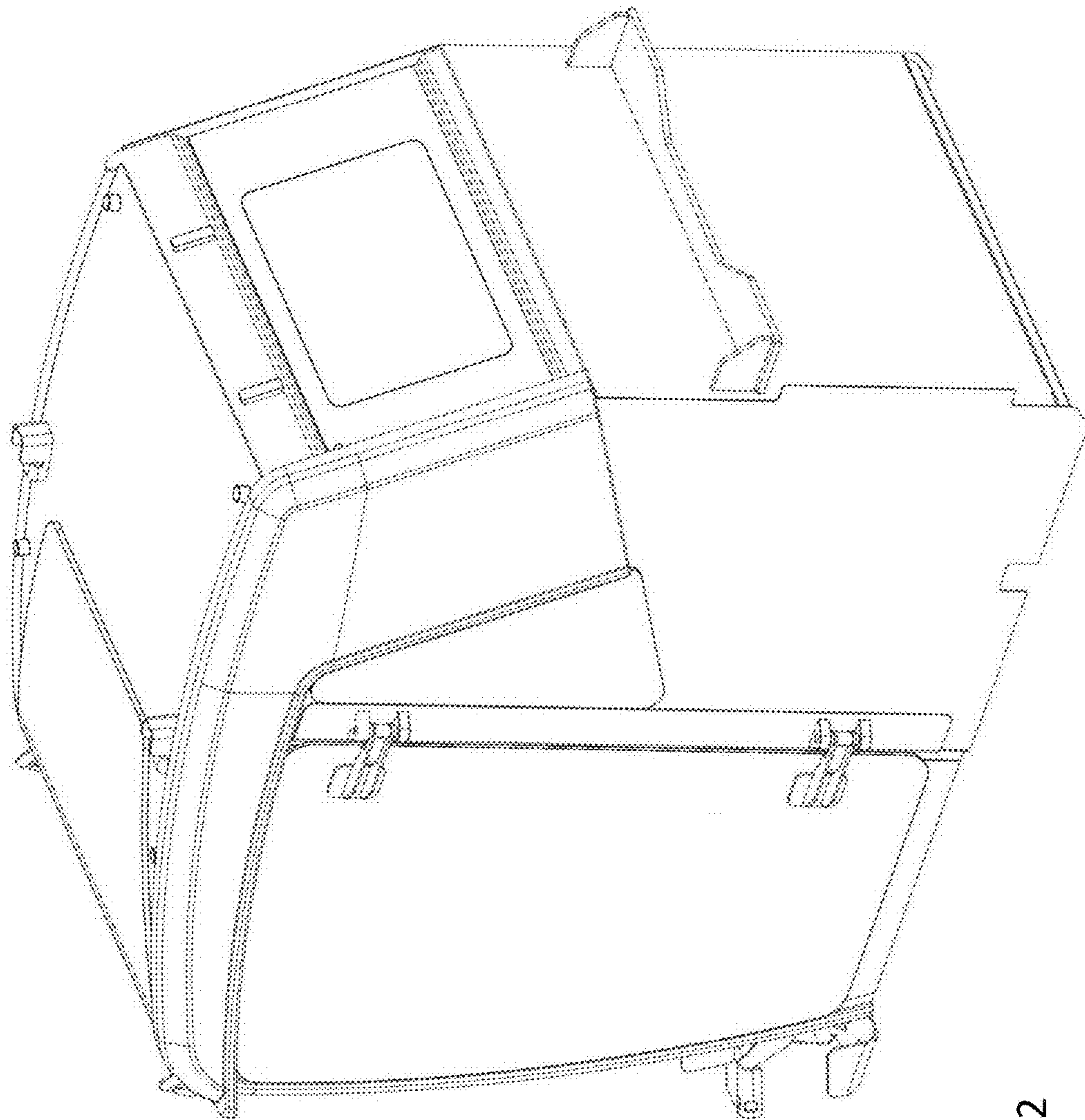

Fig. 2



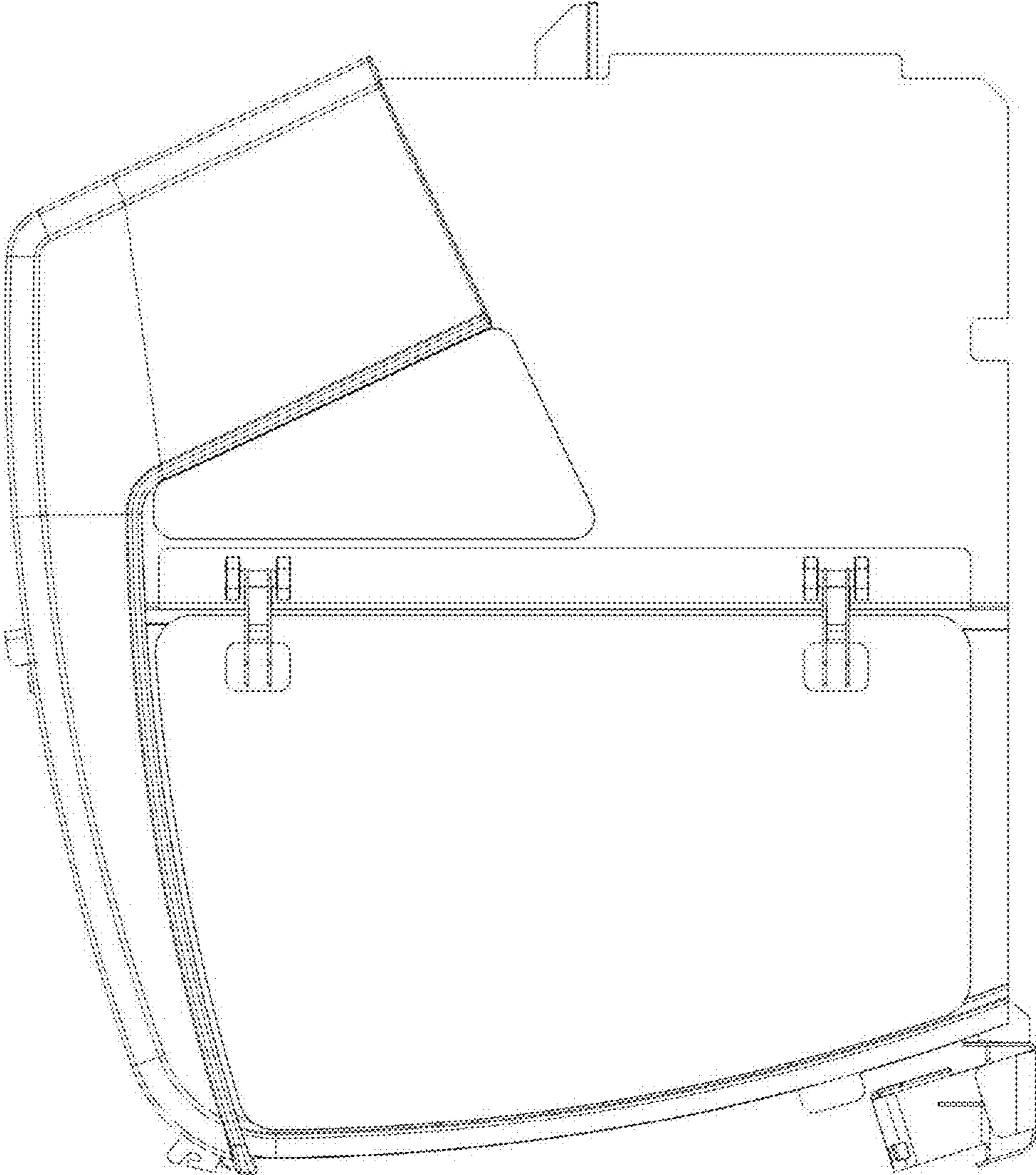

Fig. 3

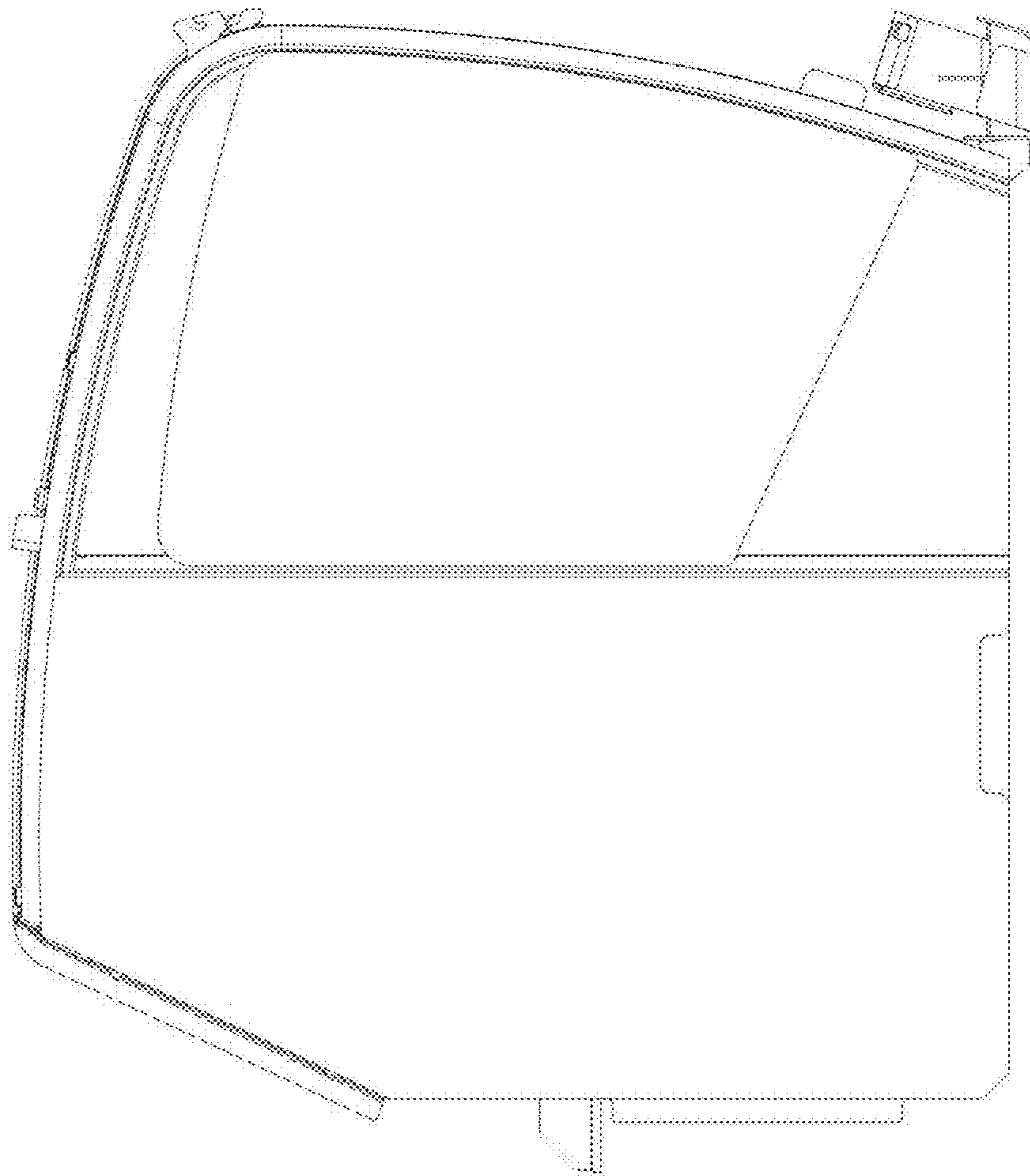

Fig. 4

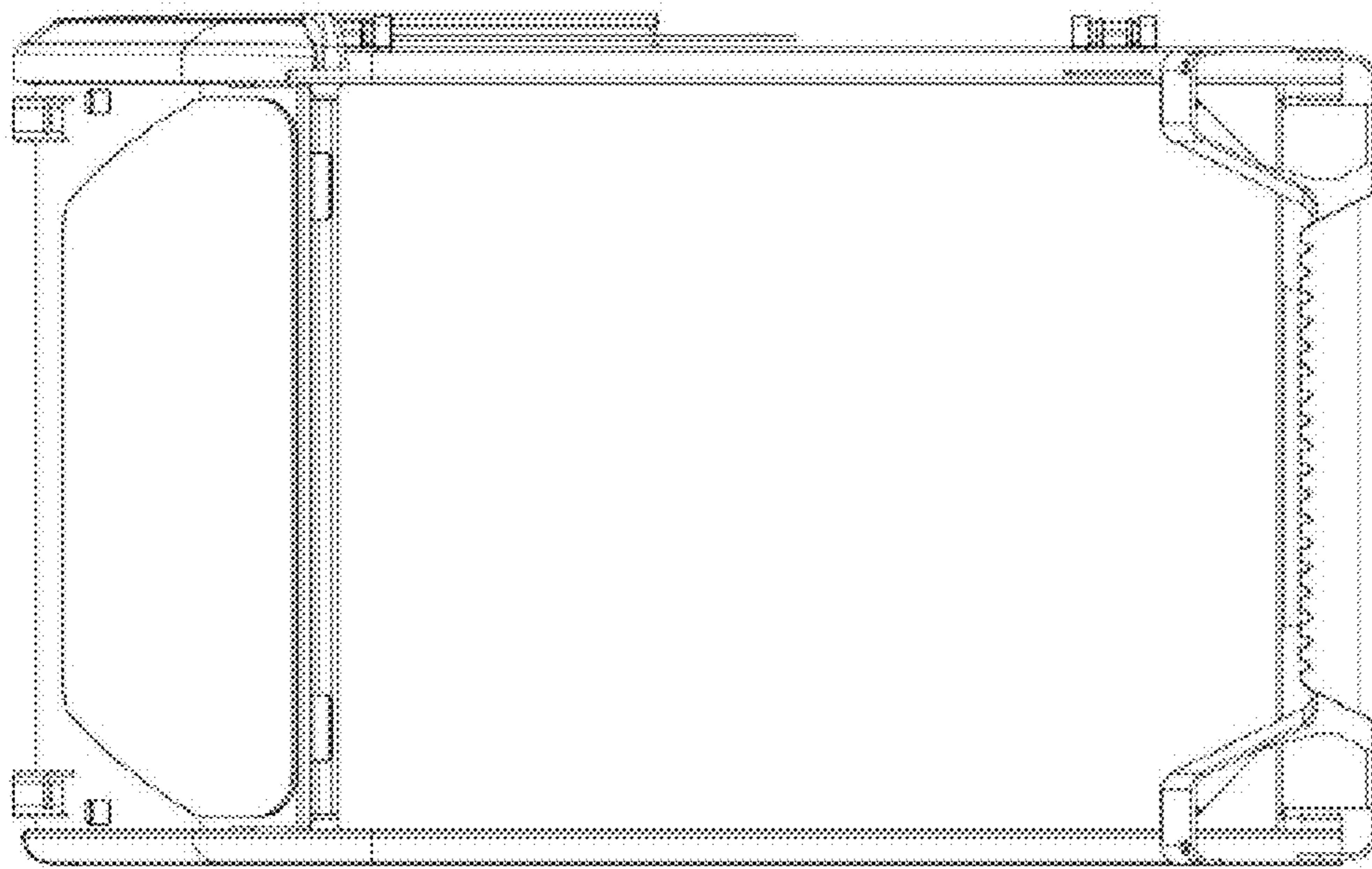

Fig. 5

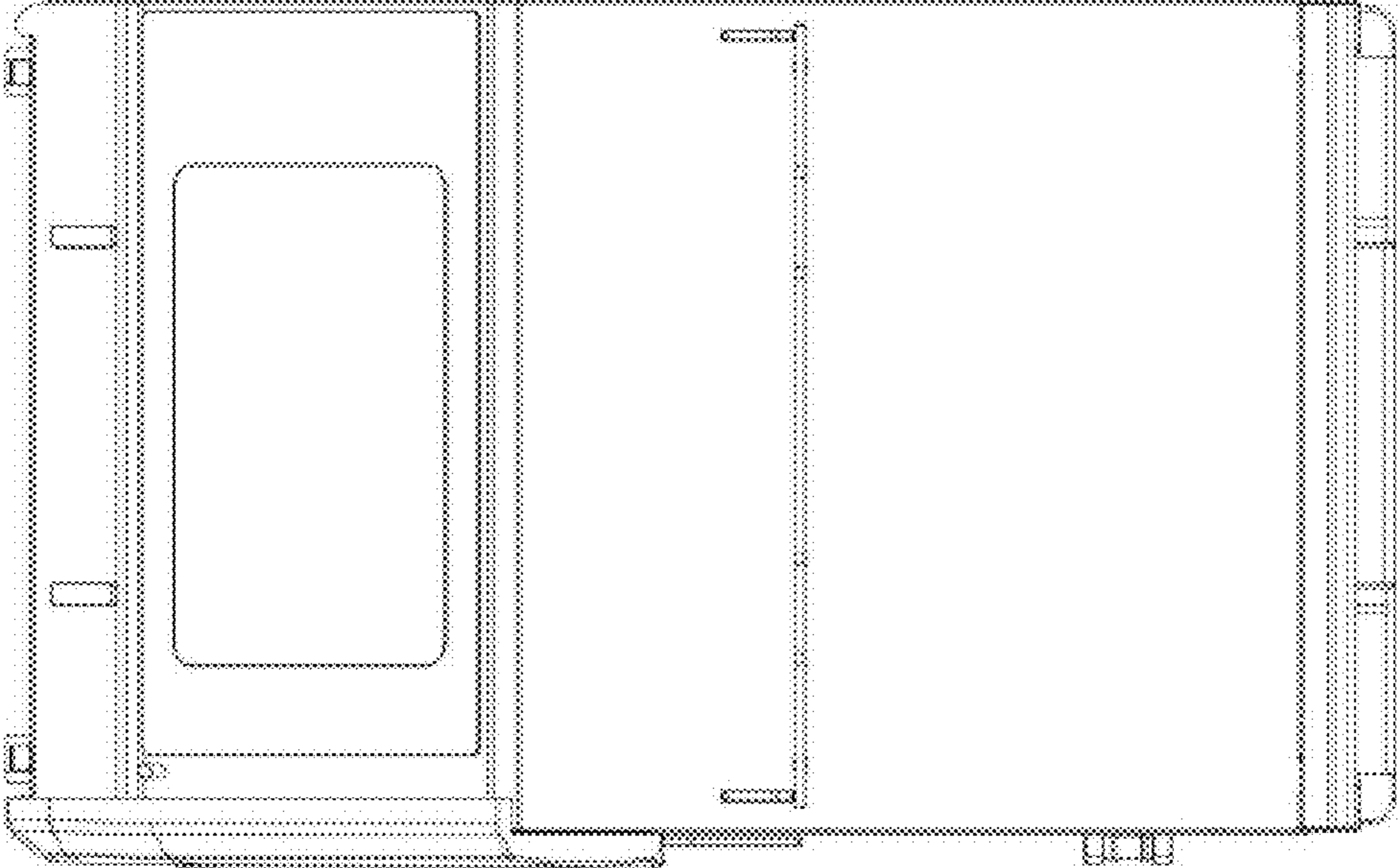

Fig. 6

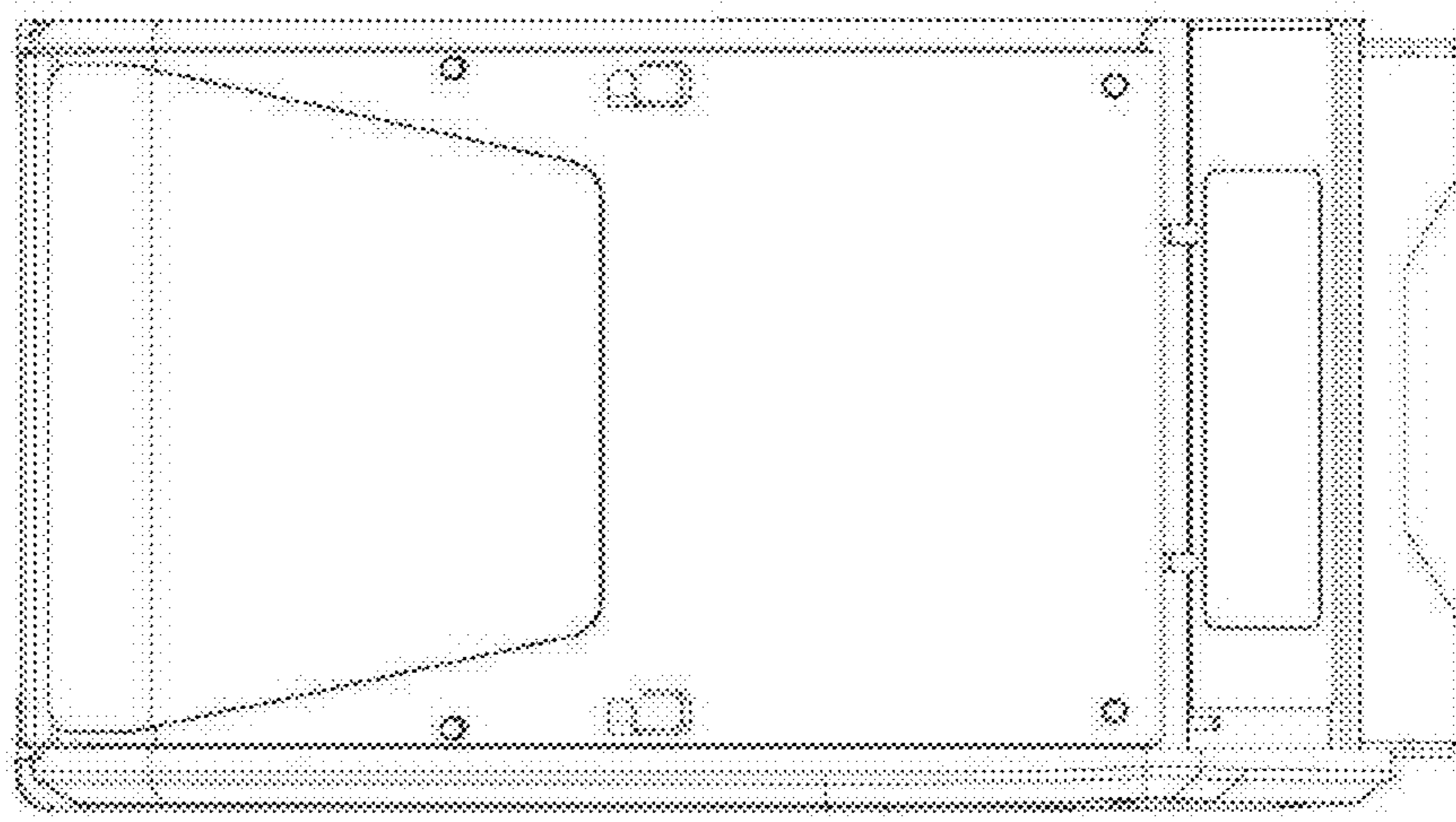

Fig. 7