



US00D780079S

(12) **United States Design Patent**
Webb et al.

(10) **Patent No.:** **US D780,079 S**
(45) **Date of Patent:** **** Feb. 28, 2017**

(54) **INSTRUMENT CLUSTER**

(71) Applicants: **DENSO International America, Inc.**,
Southfield, MI (US); **DENSO**
CORPORATION, Kariya, Aichi-pref.
(JP)

(72) Inventors: **Gareth Webb**, Farmington, MD (US);
Marc Arceo, Livonia, MI (US); **Cary**
Horvath, Dearborn, MI (US)

(73) Assignees: **DENSO International America, Inc.**,
Southfield, MI (US); **DENSO**
CORPORATION, Kariya (JP)

(**) Term: **15 Years**

(21) Appl. No.: **29/537,213**

(22) Filed: **Aug. 24, 2015**

(51) **LOC (10) Cl.** **12-16**

(52) **U.S. Cl.**
USPC **D12/192**

(58) **Field of Classification Search**
USPC D12/192, 195, 415, 114; D10/102;
D15/17, 28

CPC G01D 11/28; G01D 11/30; G01D 11/24;
B60K 37/02; B60K 2350/2008

See application file for complete search history.

(56) **References Cited**

U.S. PATENT DOCUMENTS

D467,845 S * 12/2002 Pfeiffer D12/192
D516,482 S * 3/2006 Pfeiffer D12/192

D557,646 S * 12/2007 Portelance D12/192
D581,302 S * 11/2008 Wyszogrod D10/102
D598,832 S * 8/2009 Sauter D12/192
D611,861 S * 3/2010 Wiedeman D10/102
D631,808 S * 2/2011 Yamazaki D12/192
D635,073 S * 3/2011 Nield D12/192
D705,146 S * 5/2014 Takagi D12/192
D705,147 S * 5/2014 Kinoshita D12/192
D727,814 S * 4/2015 Paulke D12/192
9,358,888 B2 * 6/2016 Schwantner
2004/0056502 A1 * 3/2004 Jennings B60K 37/02
296/70

* cited by examiner

Primary Examiner — Phillip S Hyder

(57) **CLAIM**

The ornamental design for an instrument cluster, as shown and described.

DESCRIPTION

FIG. 1 is an perspective view illustrating the instrument cluster;

FIG. 2 is front view of the instrument cluster;

FIG. 3 is a rear view of the instrument cluster;

FIG. 4 is a right view of the instrument cluster;

FIG. 5 is a left view of the instrument cluster;

FIG. 6 is a top view of the instrument cluster; and,

FIG. 7 is a bottom view of the instrument cluster.

The rear edge of the instrument cluster is depicted by a broken line since it forms no part of the claimed design. The portions of the gauges depicted by broken lines form no part of the claimed design.

1 Claim, 5 Drawing Sheets

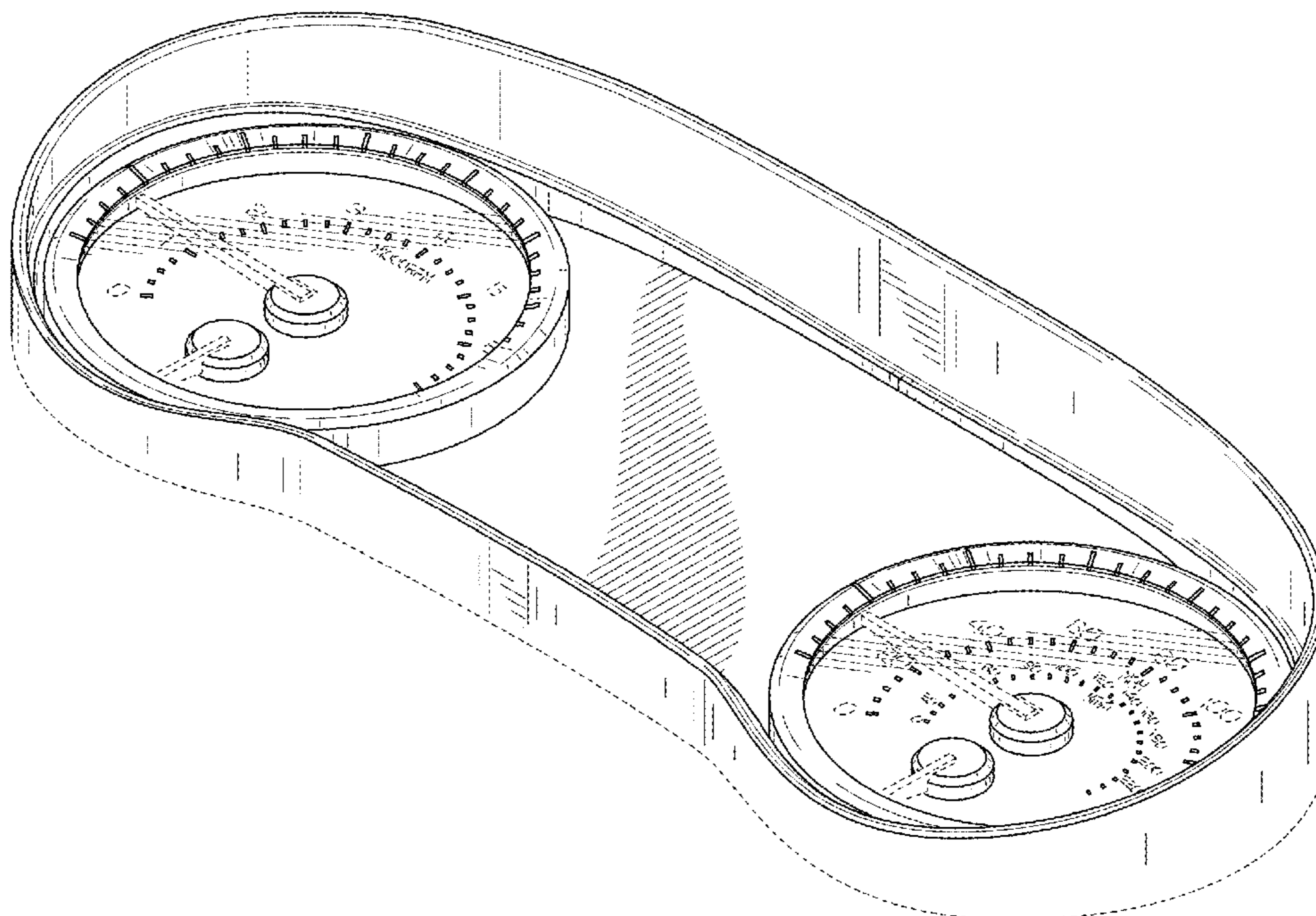

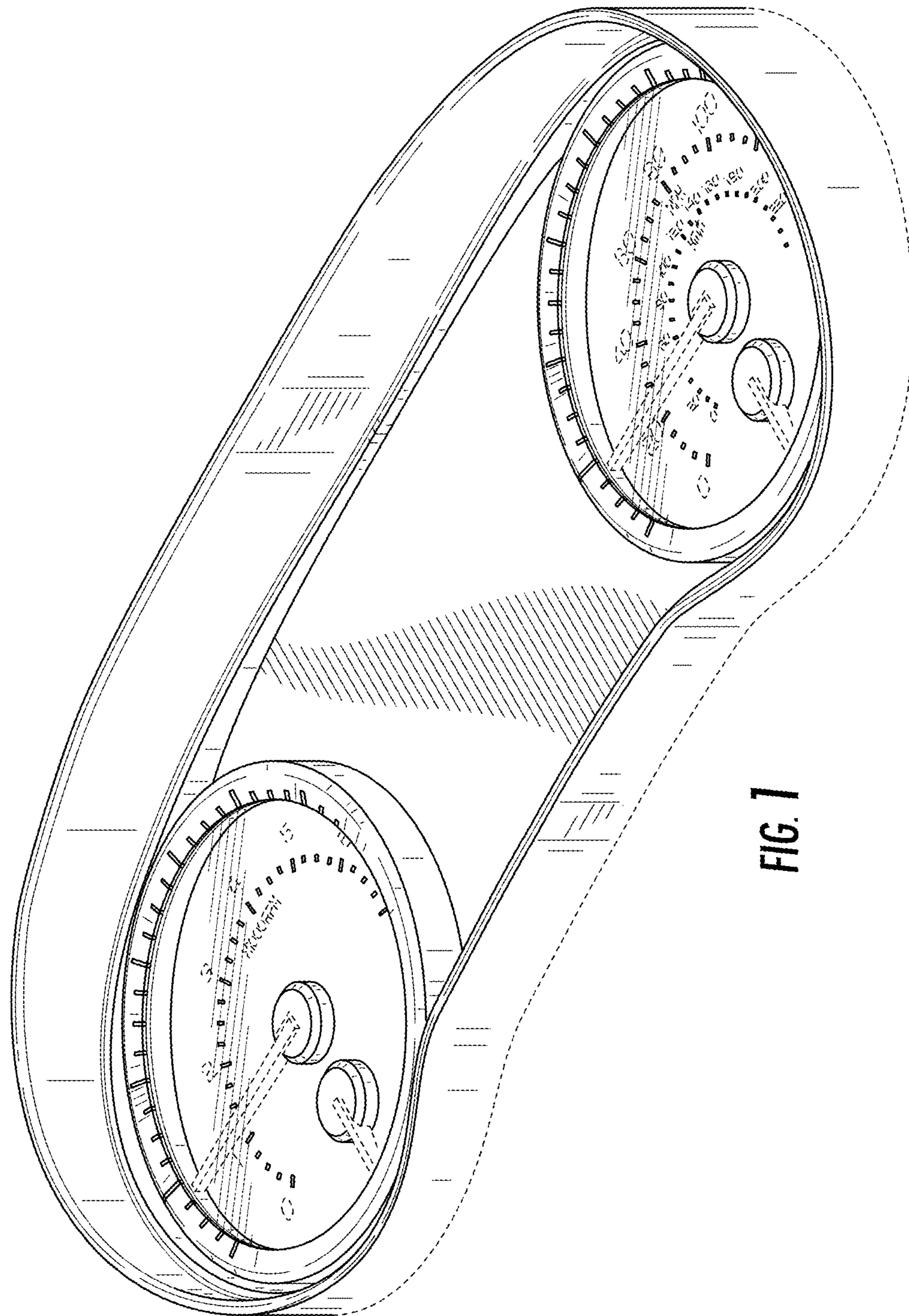

FIG. 1

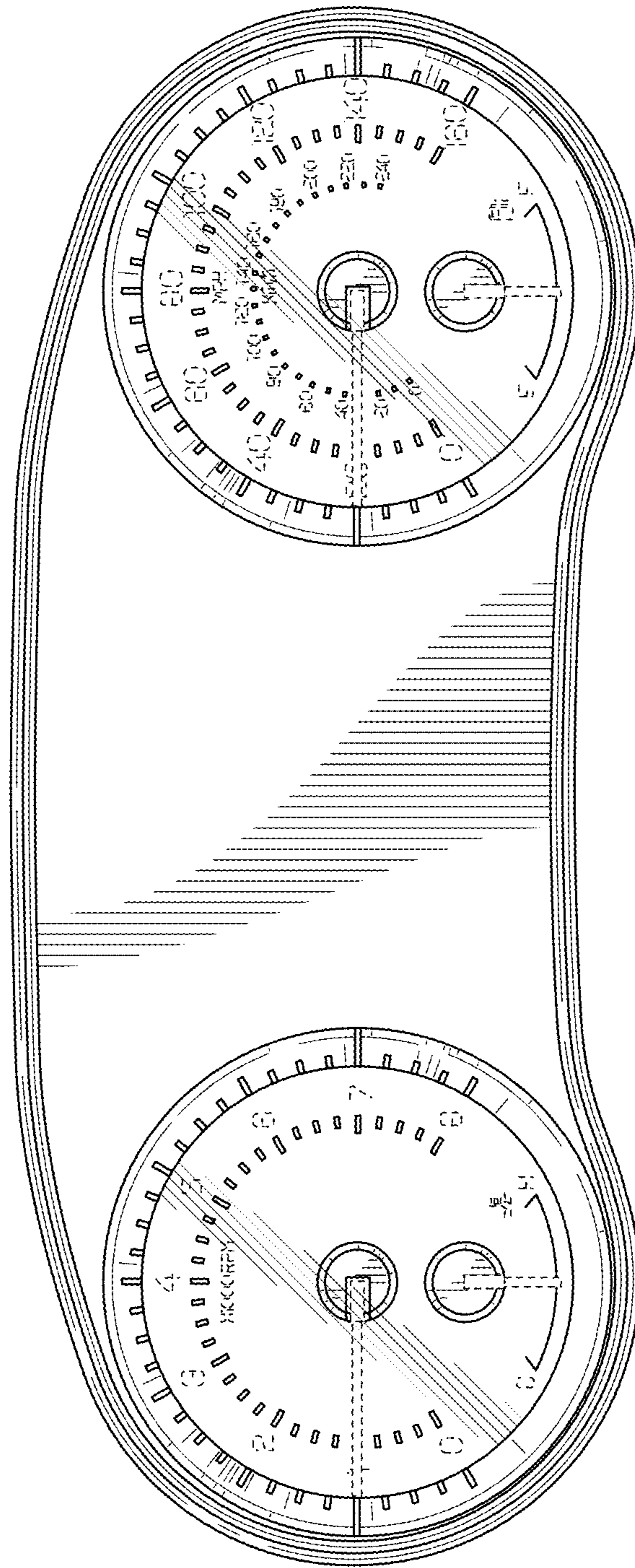

FIG. 2

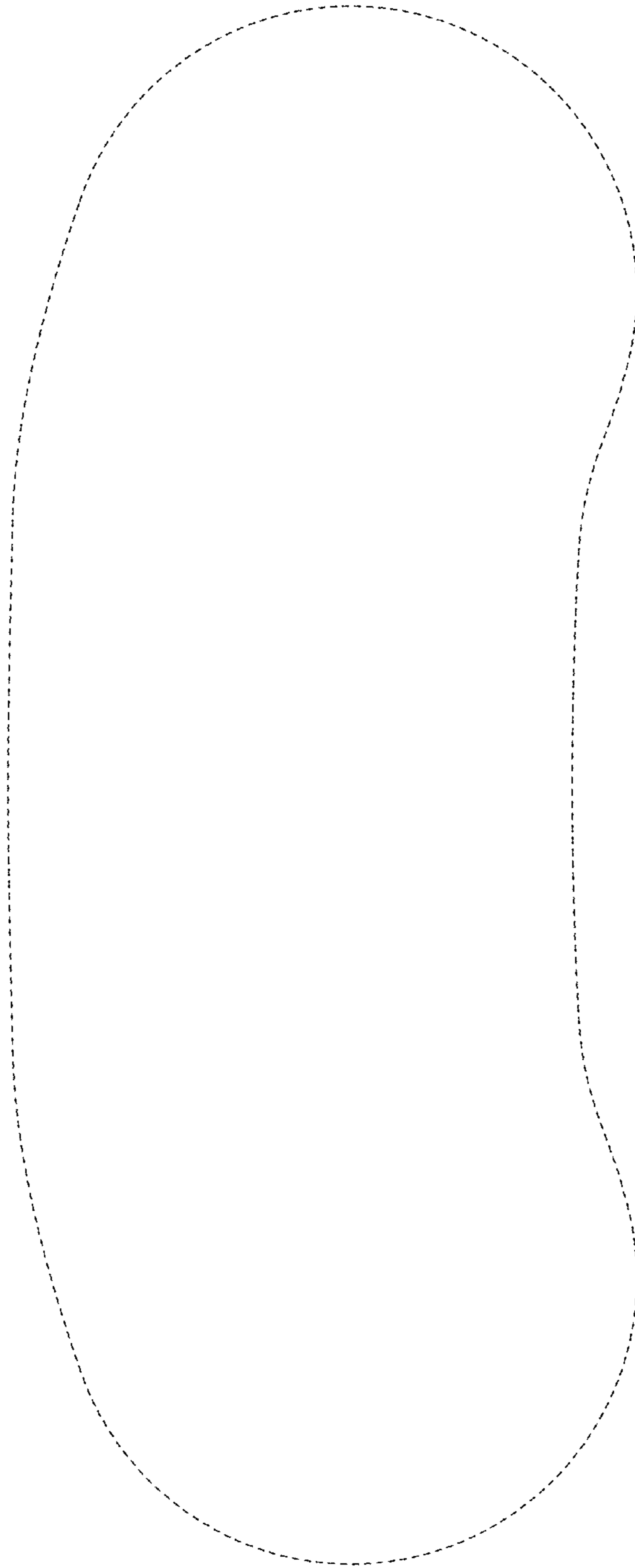

FIG. 3

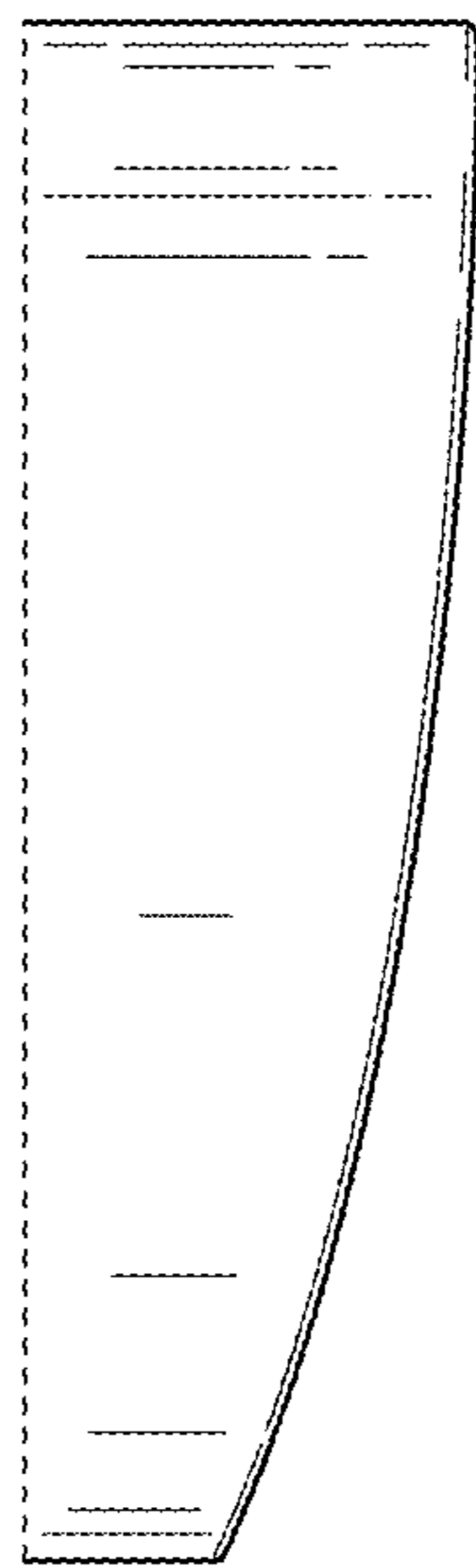

FIG. 4

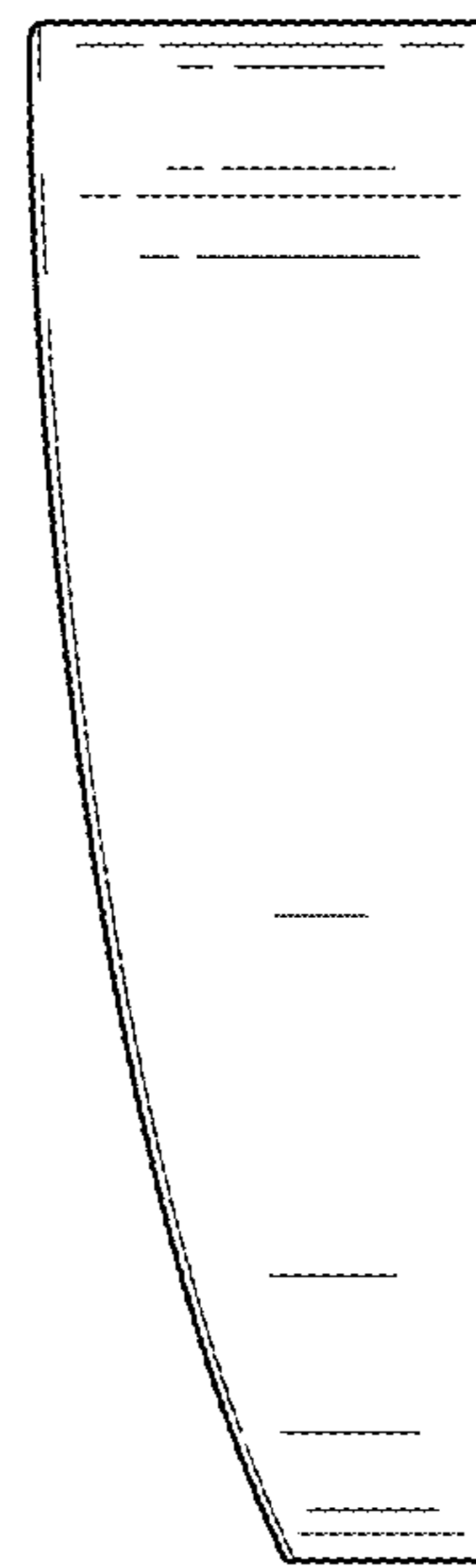

FIG. 5

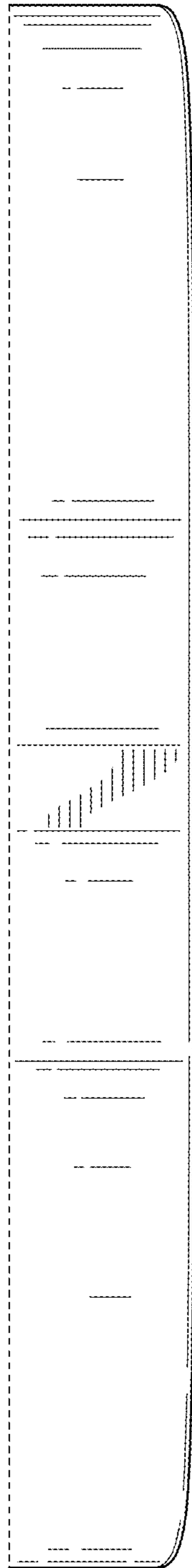

FIG. 6

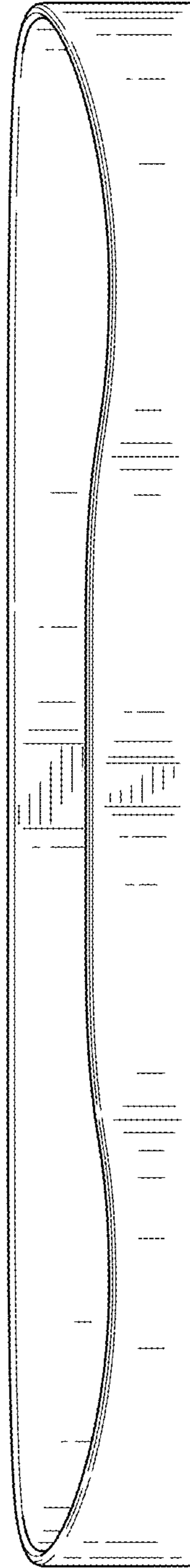

FIG. 7