



US00D779998S

(12) **United States Design Patent** (10) **Patent No.:** **US D779,998 S**
Rosenbaum et al. (45) **Date of Patent:** **** Feb. 28, 2017**

(54) **LEATHER LACE BRACELET**

DESCRIPTION

(71) Applicants: **Alexis Rosenbaum**, Maineville, OH (US); **Hannah King**, Folsom, CA (US)

FIG. 1 is a perspective view of a first embodiment of a leather lace bracelet of the present invention in a wrapped configuration.

(72) Inventors: **Alexis Rosenbaum**, Maineville, OH (US); **Hannah King**, Folsom, CA (US)

FIG. 2 is an enlarged perspective view of FIG. 1 of the leather lace bracelet.

(73) Assignee: **Modern Home Management LLC**, Maineville, OH (US)

FIG. 3 is a perspective view of the first embodiment of the leather lace bracelet of the present invention in an unwrapped configuration.

(**) Term: **14 Years**

FIG. 4 is a top view of FIG. 3 of the leather lace bracelet. FIG. 5 is a right side view of FIG. 3 of the leather lace bracelet; the left side view is a mirror image thereof.

(21) Appl. No.: **29/494,645**

FIG. 6 is a bottom view of FIG. 3 of the leather lace bracelet. FIG. 7 is a front view of FIG. 3 of the leather lace bracelet.

(22) Filed: **Jun. 23, 2014**

FIG. 8 is a rear view of FIG. 3 of the leather lace bracelet.

(51) **LOC (10) Cl.** **11-01**

FIG. 9 is an enlarged portion of the circle area 9 of the leather lace bracelet of FIG. 5.

(52) **U.S. Cl.** **D11/5**

FIG. 10 is a perspective view of a second embodiment of a leather lace bracelet of the present invention in an unwrapped configuration.

USPC **D11/5**

FIG. 11 is a top view of FIG. 10 of the leather lace bracelet. FIG. 12 is a right side view of FIG. 10 of the leather lace bracelet; the left side view is a mirror image thereof.

(58) **Field of Classification Search** **D11/1-25**

FIG. 13 is a bottom view of FIG. 10 of the leather lace bracelet.

USPC **D11/1-25**

(Continued)

(56) **References Cited**

FIG. 14 is a front view of FIG. 10 of the leather lace bracelet. FIG. 15 is a rear view of FIG. 10 of the leather lace bracelet; and,

U.S. PATENT DOCUMENTS

D163,991 S * 7/1951 Chernow D11/8
D509,765 S * 9/2005 Lishen D11/3

FIG. 16 is an enlarged portion of the circle area 16 of the leather lace bracelet of FIG. 12.

(Continued)

OTHER PUBLICATIONS

[Online] https://84d55e5b6cda69d72a93-0d45cfb3063cfb137c1771d50facb0dd.ssl.cf1.rackcdn.com/436/9/5_13_1422655285_3060_xl.jpg. Retrieved Feb. 5, 2016.*

The straight line shading illustrates the smooth side of the leather.

(Continued)

The stipple shading illustrates the raw side of the leather. The broken lines represent portions of the leather lace bracelet which form no part of the claimed design.

Primary Examiner — Melanie Pellegrini
(74) *Attorney, Agent, or Firm* — Wood, Herron & Evans, LLP

The dot-dash style broken lines showing a hand in FIG. 1 represent environment and form no part of the claim. The dot-dash style broken lines in FIGS. 5, 9, 12 and 16 represent an unclaimed boundary.

(57) **CLAIM**

The ornamental design for a leather lace bracelet, as shown and described.

The break lines shown in FIGS. 3-6 have been included in order to show the design at a large scale and the design is understood to continue uniformly between the break lines and be of the length shown in FIGS. 1 and 2. FIGS. 10-13

(Continued)

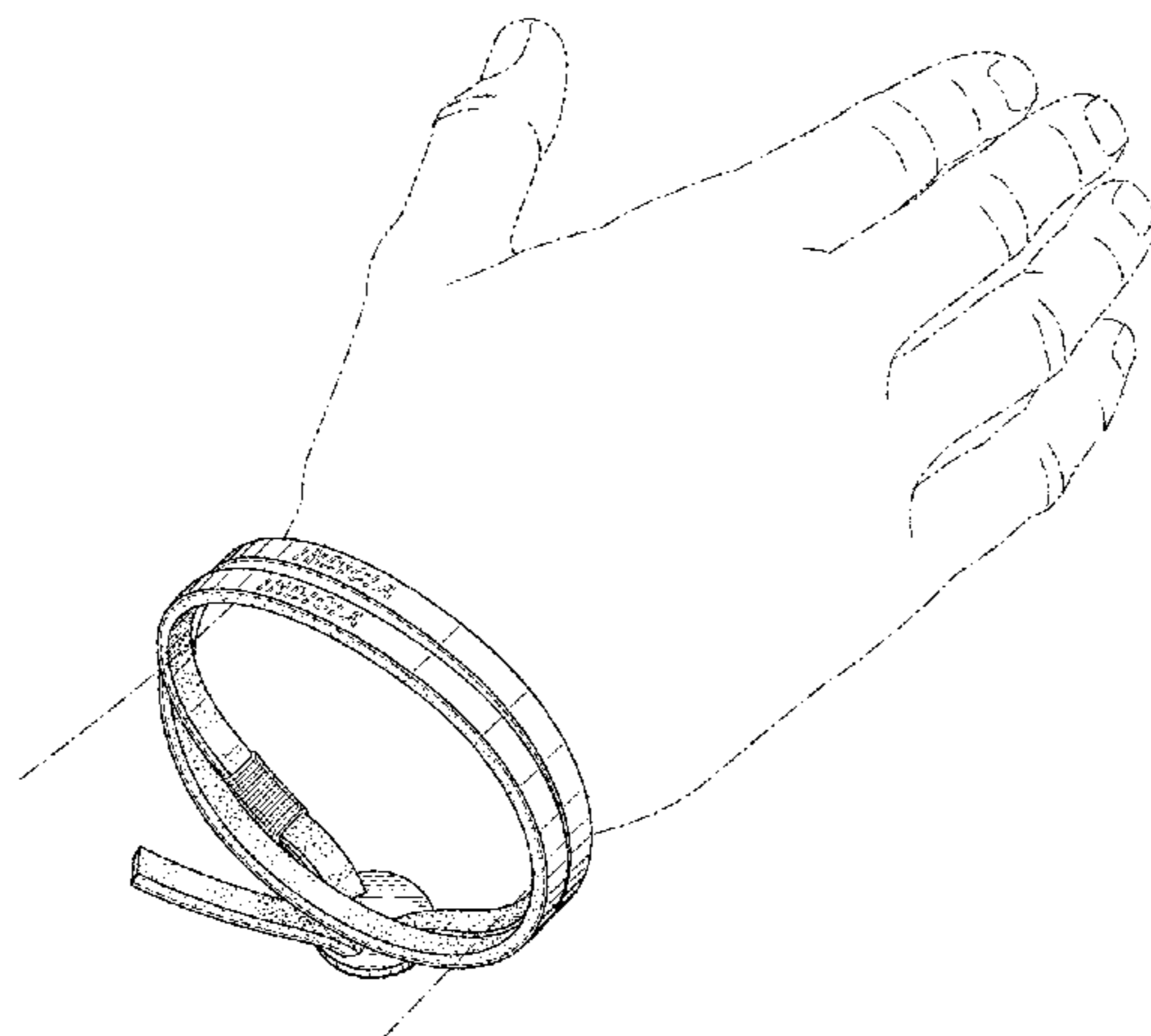

also include break lines and the appearance of any portion of the article between the break lines forms no part of the claimed design.

1 Claim, 6 Drawing Sheets

D675,124 S *	1/2013	Rowland	D11/5
D690,219 S *	9/2013	Mouquet	D11/5
D712,294 S *	9/2014	Wright	D11/1
D713,283 S *	9/2014	Nghiem	D11/3
2006/0265878 A1 *	11/2006	Zorman	A44C 5/0053 29/896.411

(58) Field of Classification Search

CPC A44C 5/00; A44C 5/0007; A44C 5/0053; A44C 5/0061; A44C 5/0069; A44C 5/0076; A44C 5/142; A44C 5/246; A44C 9/0038; A44C 9/0053; A44C 9/02; Y10T 29/49838; Y10T 29/49591

See application file for complete search history.

(56) References Cited

U.S. PATENT DOCUMENTS

D623,978 S *	9/2010	Cerullo	D11/3
D644,138 S *	8/2011	Webb	D11/3

OTHER PUBLICATIONS

[Online] <https://web.archive.org/web/20130225135508/http://www.aaronbasha.com/collections/leather-strap-bracelets>. Retrieved Feb. 5, 2016. Posted online at least as early as Feb. 25, 2013.*
https://www.etsy.com/listing/185474222/womens-red-leather-wrap-bracelet-hafair?utm_source=google&utm_medium=product_listing_promoted&utm_campaign=jewelry_low&gclid=CKKE14nx9L4CFVQiMgodzDUAWg, Retrieved Jun. 25, 2014.
https://www.etsy.com/listing/157632120/mens-personalized-jewelry-custom-hand?ref=shop_home_active_16, Retrieved Jun. 25, 2014.

* cited by examiner

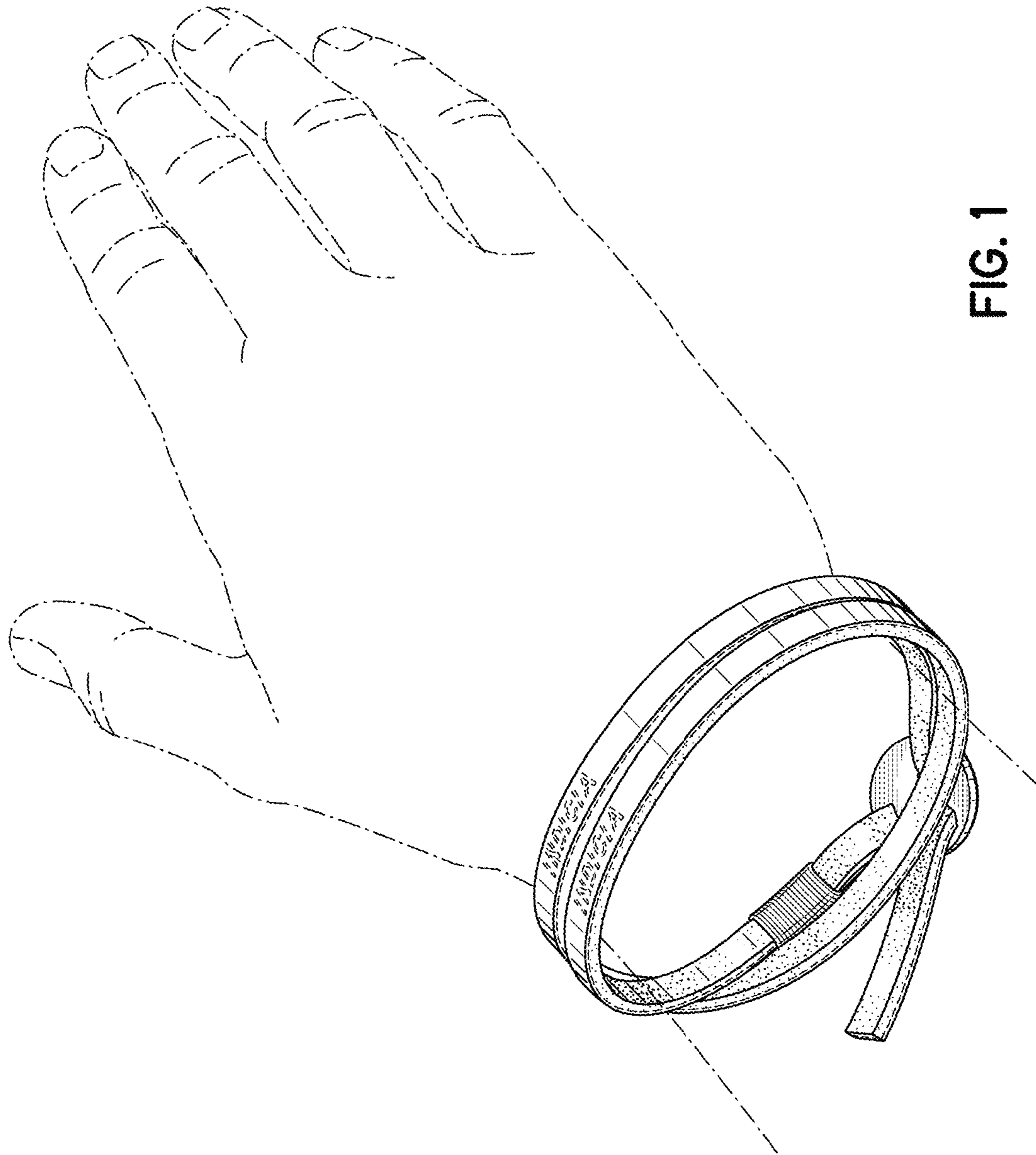

FIG. 1

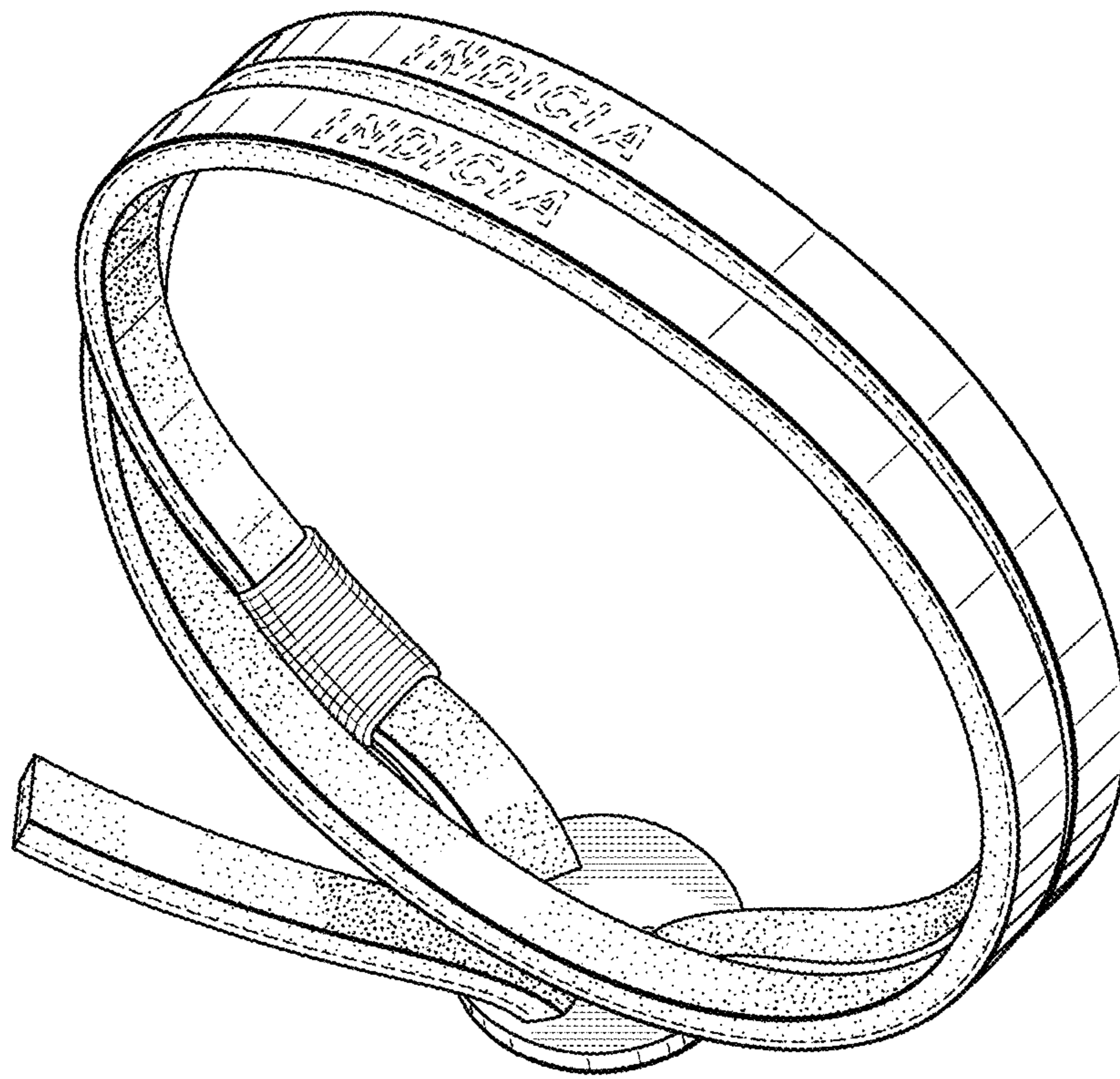

FIG. 2

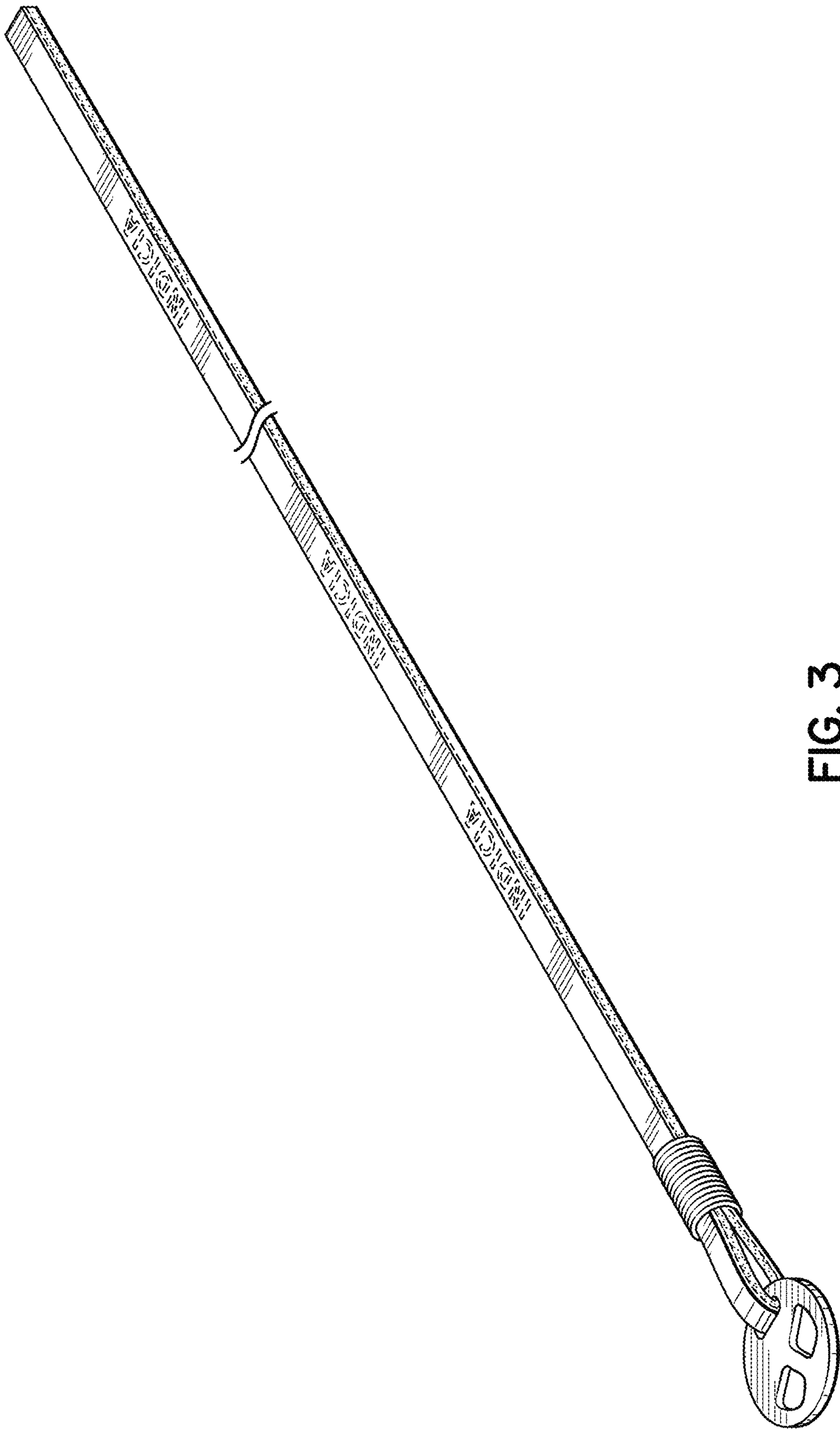

FIG. 3



FIG. 4

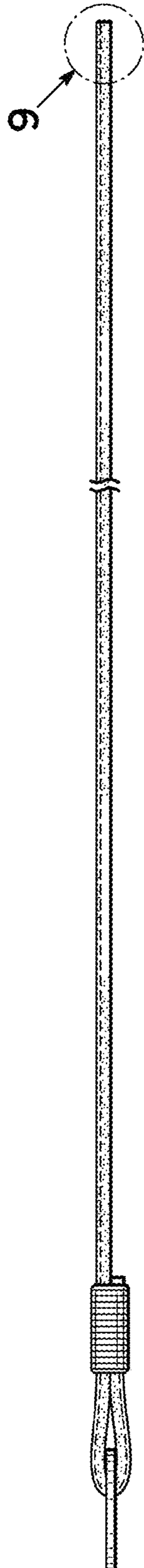

FIG. 5

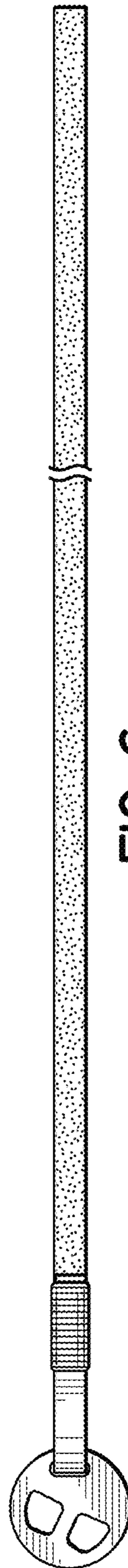

FIG. 6



FIG. 7



FIG. 8

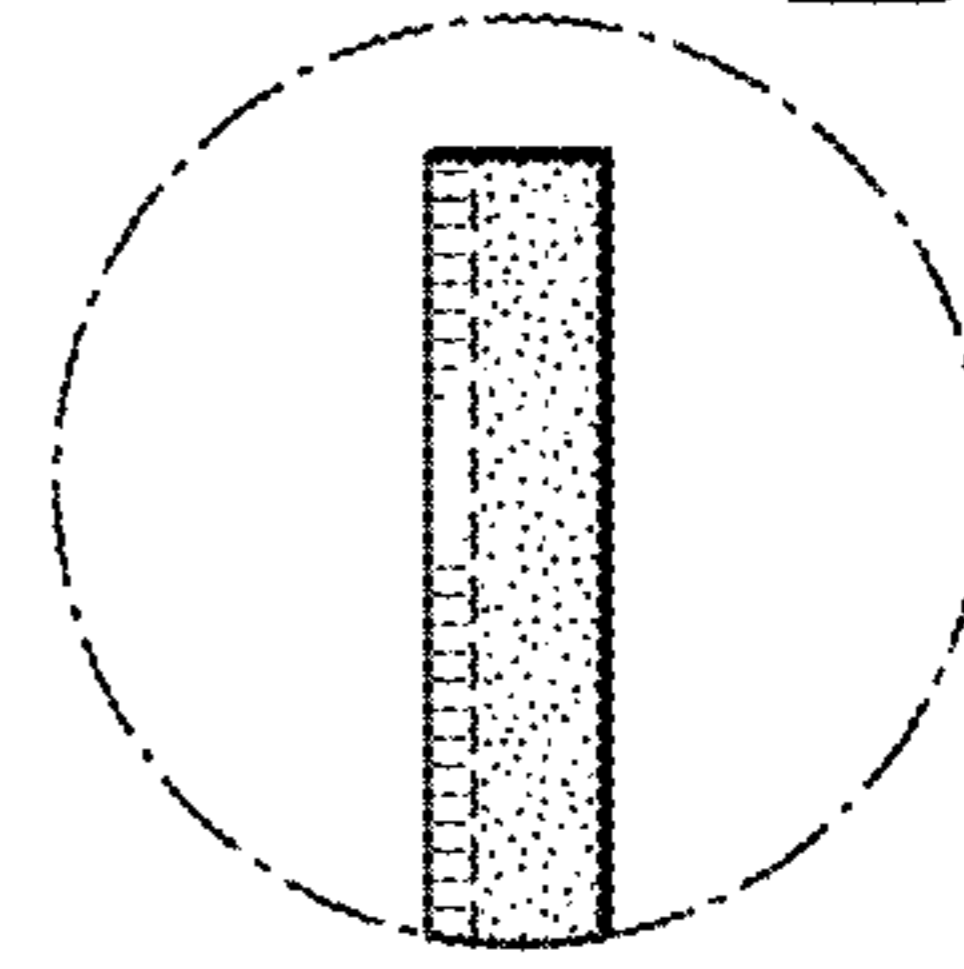

FIG. 9

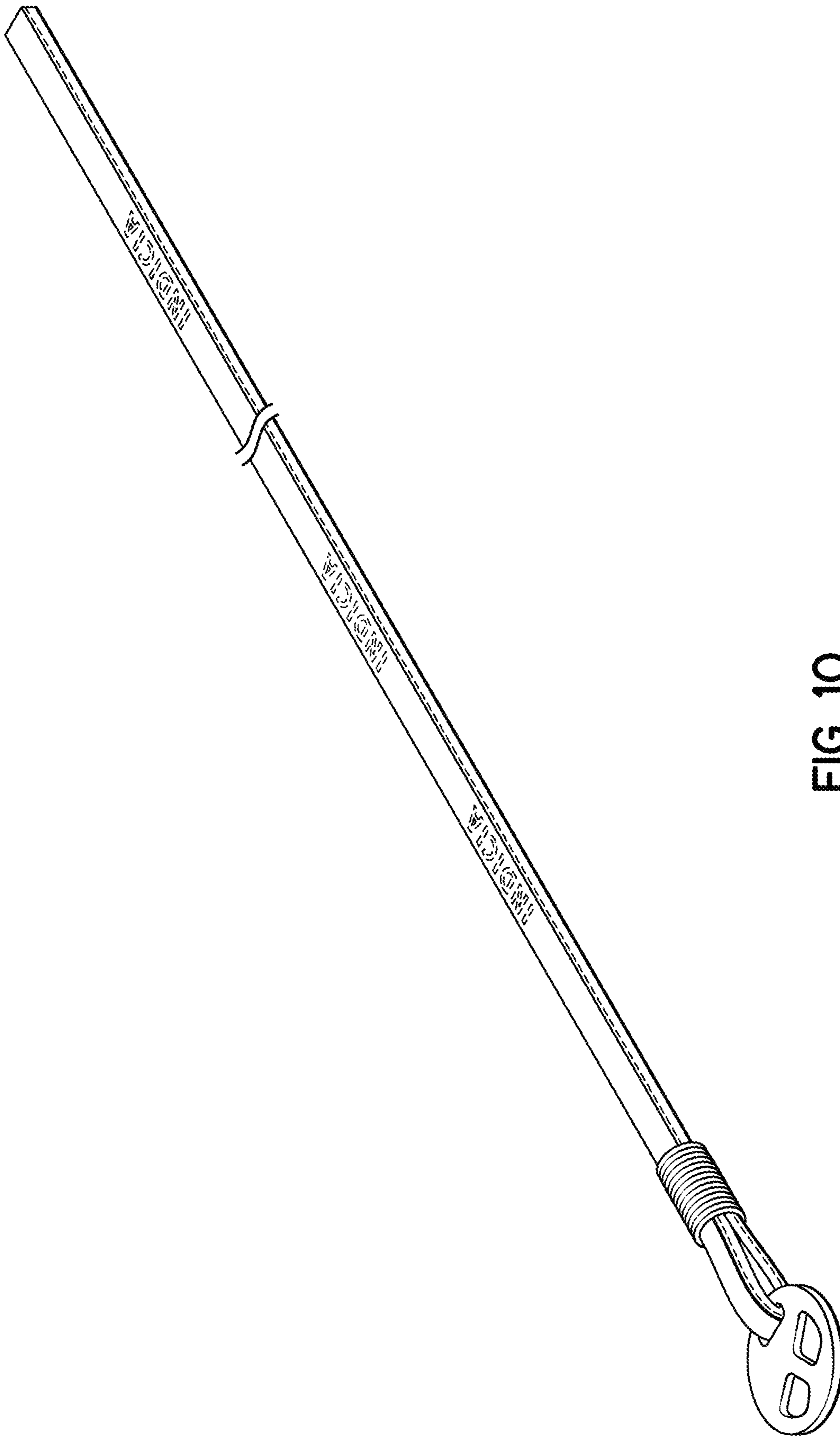

FIG. 10

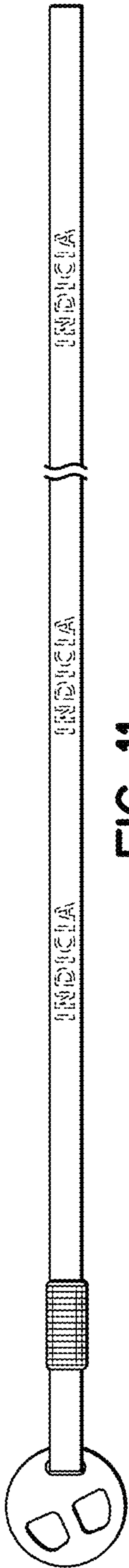

FIG. 11

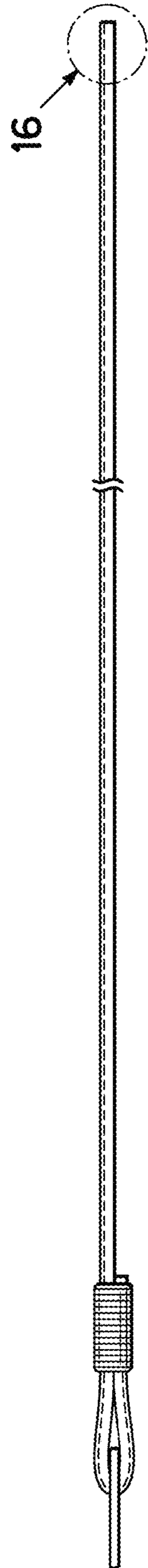

FIG. 12



FIG. 13



FIG. 14



FIG. 15

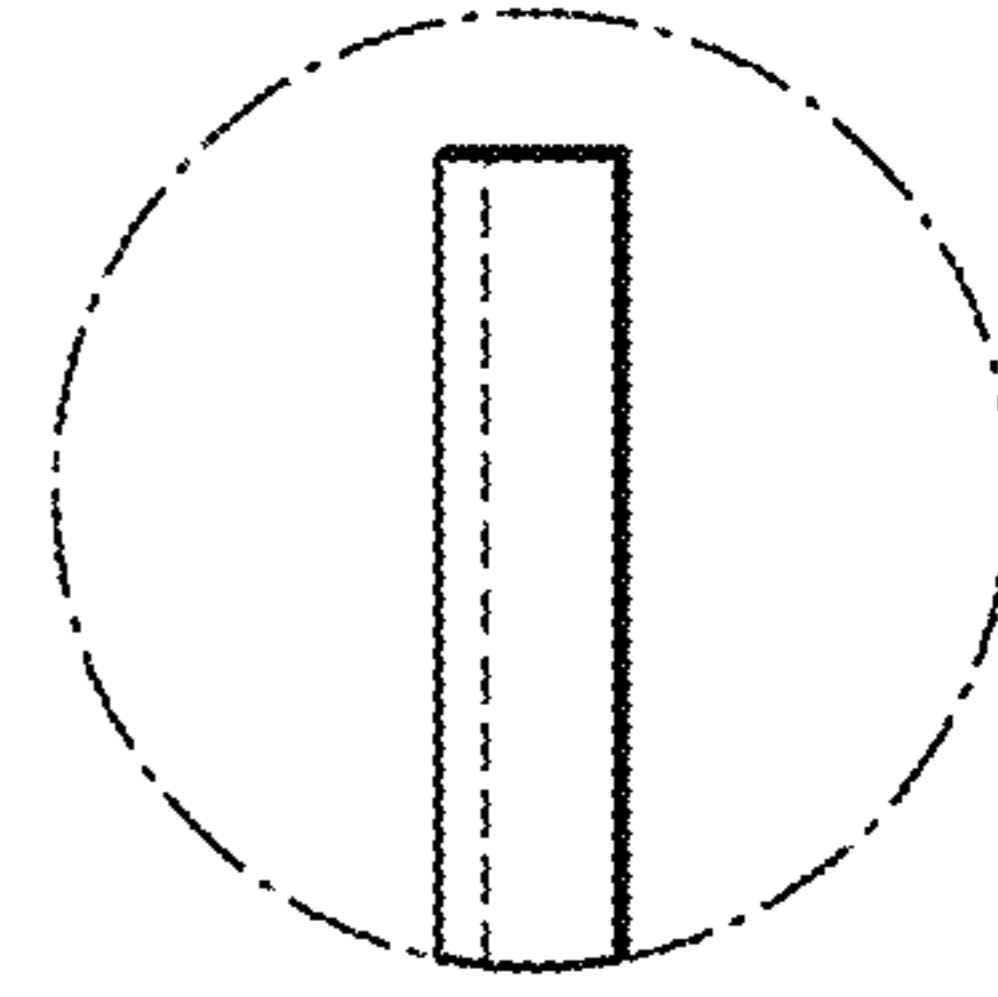

FIG. 16