



US00D779682S

(12) **United States Design Patent** (10) **Patent No.:** **US D779,682 S**
Walsh (45) **Date of Patent:** **** Feb. 21, 2017**

(54) **LIGHT PANEL**
(71) Applicant: **Masonite Corporation**, Tampa, FL (US)
(72) Inventor: **Jason Walsh**, Batavia, IL (US)
(73) Assignee: **Masonite Corporation**, Tampa, FL (US)
(**) Term: **14 Years**
(21) Appl. No.: **29/487,779**
(22) Filed: **Apr. 11, 2014**

D388,885 S	1/1998	Lint et al.	
D396,299 S	7/1998	Lee	
D402,378 S	12/1998	Parkhurst	
D405,547 S	2/1999	Dobija	
D415,291 S	10/1999	Woodruff	
D475,222 S	6/2003	Brandon	
D477,938 S	8/2003	Brandon	
D490,909 S	6/2004	Barnard	
D533,284 S	12/2006	Bledsoe et al.	
D533,949 S	12/2006	Kaspari et al.	
D535,759 S	1/2007	Kaspari et al.	
D537,544 S	2/2007	Bledsoe et al.	
D552,759 S	10/2007	Murdock	
D558,359 S	12/2007	Mathias et al.	
D559,408 S	1/2008	Dorris	
D589,158 S	3/2009	Hu	
D590,069 S	4/2009	Hu	
D608,022 S	1/2010	Metcalf et al.	
D608,026 S	1/2010	Metcalf et al.	
D608,027 S	1/2010	Metcalf	
D608,461 S	1/2010	Hu	
D608,905 S	1/2010	Walsh et al.	
D611,618 S	3/2010	Walsh et al.	
D611,619 S	3/2010	Walsh et al.	
D612,518 S	3/2010	Hu	
D613,879 S	4/2010	Hu	
D617,473 S	6/2010	Suare et al.	
D627,083 S	11/2010	Walsh et al.	
D631,173 S	1/2011	Hu	
D634,027 S	* 3/2011	Hu	D25/103
D641,921 S	7/2011	Sabernig	
D642,285 S	7/2011	Hu	
D664,676 S	7/2012	Walsh	
D666,314 S	* 8/2012	Walsh	D25/103
D670,005 S	* 10/2012	Walsh	D25/103
D692,164 S	* 10/2013	Walsh	D25/103
D692,584 S	* 10/2013	Walsh	D25/103
D694,429 S	* 11/2013	Walsh	D25/103
D695,419 S	* 12/2013	Groening	D25/103
D702,856 S	* 4/2014	Walsh	D25/103
D705,451 S	* 5/2014	Hu	D25/103
D706,954 S	* 6/2014	Walsh	D25/103
D751,219 S	* 3/2016	Walsh	D25/103
D751,220 S	* 3/2016	Walsh	D25/103
D753,845 S	* 4/2016	Walsh	D25/103

Related U.S. Application Data

(62) Division of application No. 29/430,601, filed on Aug. 28, 2012, now Pat. No. Des. 702,856, which is a division of application No. 29/350,285, filed on Nov. 13, 2009, now Pat. No. Des. 666,314.
(51) **LOC (10) Cl.** **25-01**
(52) **U.S. Cl.**
USPC **D25/103**
(58) **Field of Classification Search**
USPC D25/103, 110, 111, 106
CPC ... B44F 11/04; B44C 5/00; B44C 3/12; B44C 3/123; B44C 5/04; B44C 5/0407; E04F 19/00; E06B 7/30
See application file for complete search history.

(56) **References Cited**

U.S. PATENT DOCUMENTS

D68,086 S	*	9/1925	Brown	D25/103
D96,836 S		9/1935	Hormes		
D188,213 S		6/1960	Barto		
D193,157 S		7/1962	O'Donoghue		
D215,589 S		10/1969	Hooton		
D259,958 S		7/1981	Shaffer		
D260,290 S		8/1981	Shaffer et al.		
D260,438 S		8/1981	Martinelli		
D270,477 S		9/1983	Taylor		
D330,435 S		10/1992	Dukart et al.		
D380,839 S		7/1997	Lint et al.		

OTHER PUBLICATIONS

Falling Leaves Stained Glass Panel, Mar. 19, 2009, http://etsyglass.blogspot.com/2009_03_01_archive.html.

* cited by examiner

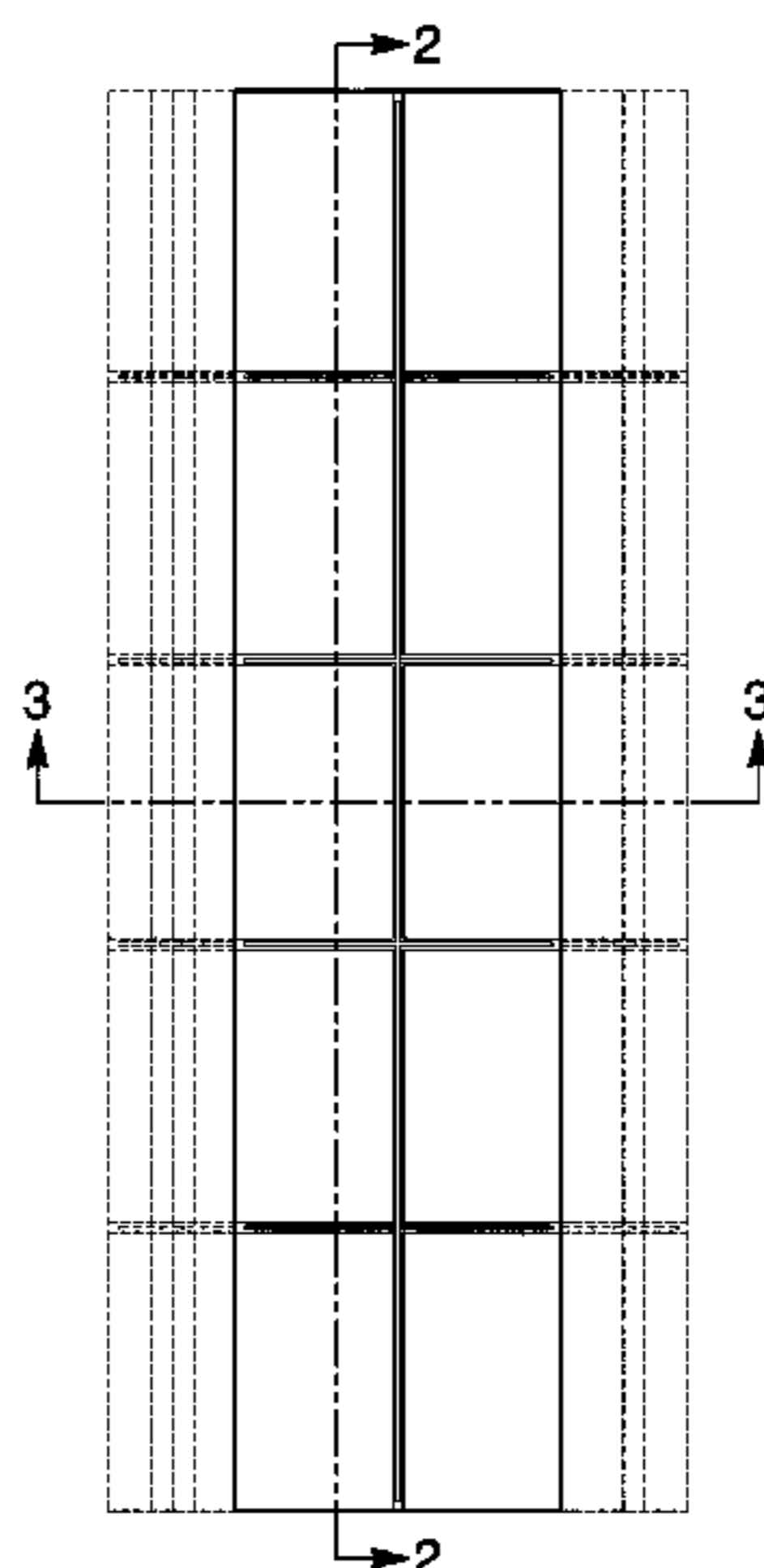

Primary Examiner — Angela J Lee

(74) Attorney, Agent, or Firm — Berenato & White, LLC

(57) **CLAIM**

The ornamental design for a light panel, as shown and described.

DESCRIPTION

FIG. 1 is a front elevational view of a first embodiment of a light panel showing my design;
 FIG. 2 is a cross-sectional view taken along the line 2-2 of FIG. 1;
 FIG. 3 is a cross-sectional view taken along the line 3-3 of FIG. 1;
 FIG. 4 is an enlarged view of a detail of FIG. 3;
 FIG. 5 is a front elevational view of a second embodiment of a light panel showing my design;
 FIG. 6 is a cross-sectional view taken along the line 6-6 of FIG. 5;
 FIG. 7 is a cross-sectional view taken along the line 7-7 of FIG. 5;
 FIG. 8 is an enlarged view of a detail of FIG. 7;
 FIG. 9 is a front elevational view of a third embodiment of a light panel showing my design;
 FIG. 10 is a cross-sectional view taken along the line 10-10 of FIG. 9;
 FIG. 11 is a cross-sectional view taken along the line 11-11 of FIG. 9;
 FIG. 12 is an enlarged view of a detail of FIG. 11;
 FIG. 13 is a front elevational view of a fourth embodiment of a light panel showing my design;
 FIG. 14 is a cross-sectional view taken along the line 14-14 of FIG. 13;
 FIG. 15 is a cross-sectional view taken along the line 15-15 of FIG. 13;
 FIG. 16 is an enlarged view of a detail of FIG. 15;
 FIG. 17 is a front elevational view of a fifth embodiment of a light panel showing my design;
 FIG. 18 is a cross-sectional view taken along the line 18-18 of FIG. 17;
 FIG. 19 is a cross-sectional view taken along the line 19-19 of FIG. 17;
 FIG. 20 is an enlarged view of a detail of FIG. 19;
 FIG. 21 is a front elevational view of a sixth embodiment of a light panel showing my design;
 FIG. 22 is a cross-sectional view taken along the line 22-22 of FIG. 21;
 FIG. 23 is a cross-sectional view taken along the line 23-23 of FIG. 21;
 FIG. 24 is an enlarged view of a detail of FIG. 23;
 FIG. 25 is a front elevational view of a seventh embodiment of a light panel showing my design;
 FIG. 26 is a cross-sectional view taken along the line 26-26 of FIG. 25;
 FIG. 27 is a cross-sectional view taken along the line 27-27 of FIG. 25;
 FIG. 28 is an enlarged view of a detail of FIG. 27;
 FIG. 29 is a front elevational view of an eighth embodiment of a light panel showing my design;
 FIG. 30 is a cross-sectional view taken along the line 30-30 of FIG. 29;

FIG. 31 is a cross-sectional view taken along the line 31-31 of FIG. 29;
 FIG. 32 is an enlarged view of a detail of FIG. 31;
 FIG. 33 is a front elevational view of a ninth embodiment of a light panel showing my design;
 FIG. 34 is a cross-sectional view taken along the line 34-34 of FIG. 33;
 FIG. 35 is a cross-sectional view taken along the line 35-35 of FIG. 33;
 FIG. 36 is an enlarged view of a detail of FIG. 35;
 FIG. 37 is a front elevational view of a tenth embodiment of a light panel showing my design;
 FIG. 38 is a cross-sectional view taken along the line 38-38 of FIG. 37;
 FIG. 39 is a cross-sectional view taken along the line 39-39 of FIG. 37;
 FIG. 40 is an enlarged view of a detail of FIG. 39;
 FIG. 41 is a front elevational view of an eleventh embodiment of a light panel showing my design;
 FIG. 42 is a cross-sectional view taken along the line 42-42 of FIG. 41;
 FIG. 43 is a cross-sectional view taken along the line 43-43 of FIG. 41;
 FIG. 44 is an enlarged view of a detail of FIG. 43;
 FIG. 45 is a front elevational view of a twelfth embodiment of a light panel showing my design;
 FIG. 46 is a cross-sectional view taken along the line 46-46 of FIG. 45;
 FIG. 47 is a cross-sectional view taken along the line 47-47 of FIG. 45;
 FIG. 48 is an enlarged view of a detail of FIG. 47;
 FIG. 49 is a front elevational view of a thirteenth embodiment of a light panel showing my design;
 FIG. 50 is a cross-sectional view taken along the line 50-50 of FIG. 49;
 FIG. 51 is a cross-sectional view taken along the line 51-51 of FIG. 49;
 FIG. 52 is an enlarged view of a detail of FIG. 51;
 FIG. 53 is a front elevational view of a fourteenth embodiment of a light panel showing my design;
 FIG. 54 is a cross-sectional view taken along the line 54-54 of FIG. 53;
 FIG. 55 is a cross-sectional view taken along the line 55-55 of FIG. 53;
 FIG. 56 is an enlarged view of a detail of FIG. 55;
 FIG. 57 is a front elevational view of a fifteenth embodiment of a light panel showing my design;
 FIG. 58 is a cross-sectional view taken along the line 58-58 of FIG. 57;
 FIG. 59 is a cross-sectional view taken along the line 59-59 of FIG. 57;
 FIG. 60 is an enlarged view of a detail of FIG. 59;
 FIG. 61 is a front elevational view of a sixteenth embodiment of a light panel showing my design;
 FIG. 62 is a cross-sectional view taken along the line 62-62 of FIG. 61;
 FIG. 63 is a cross-sectional view taken along the line 63-63 of FIG. 61; and,
 FIG. 64 is an enlarged view of a detail of FIG. 63.

FIG. 1

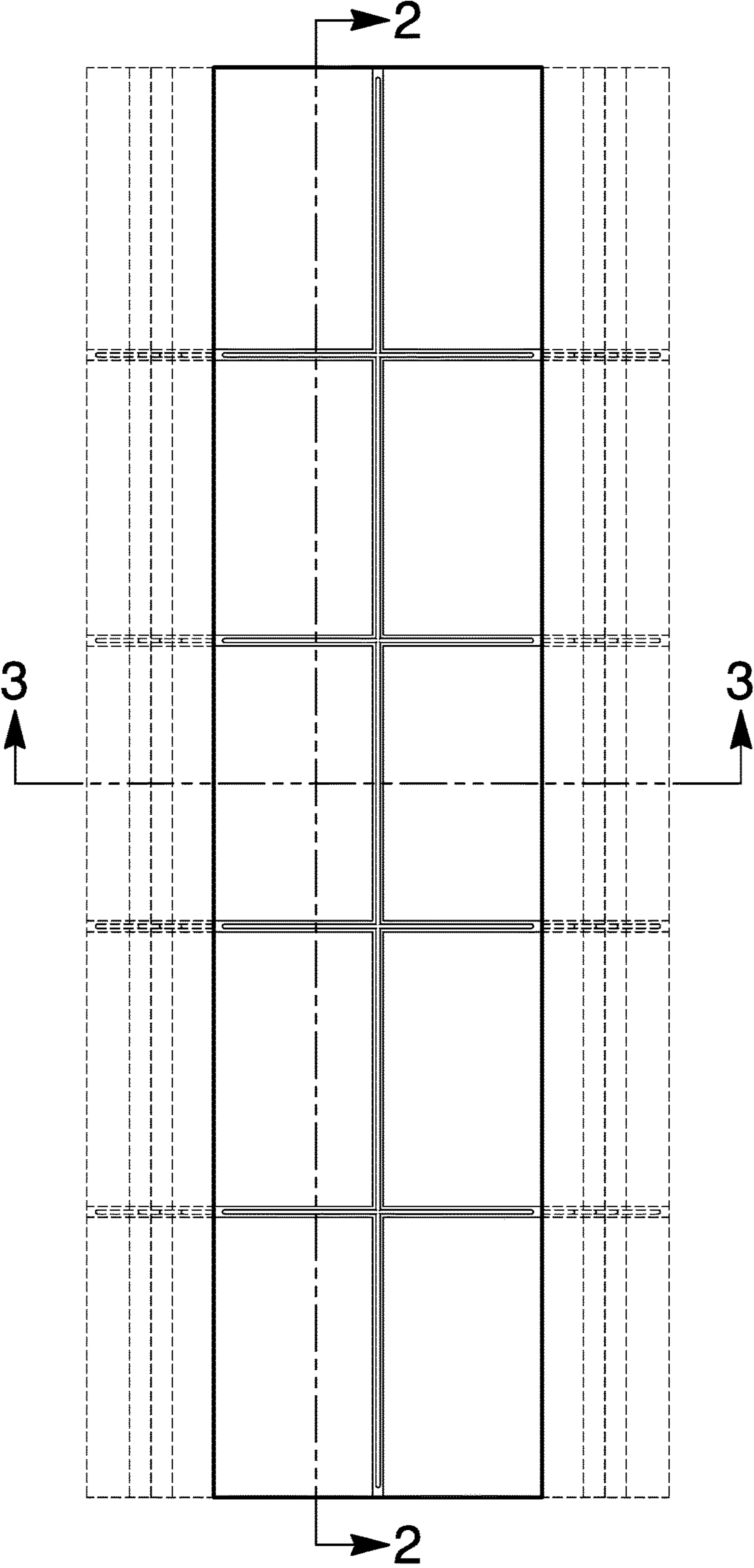

FIG. 2



FIG. 3

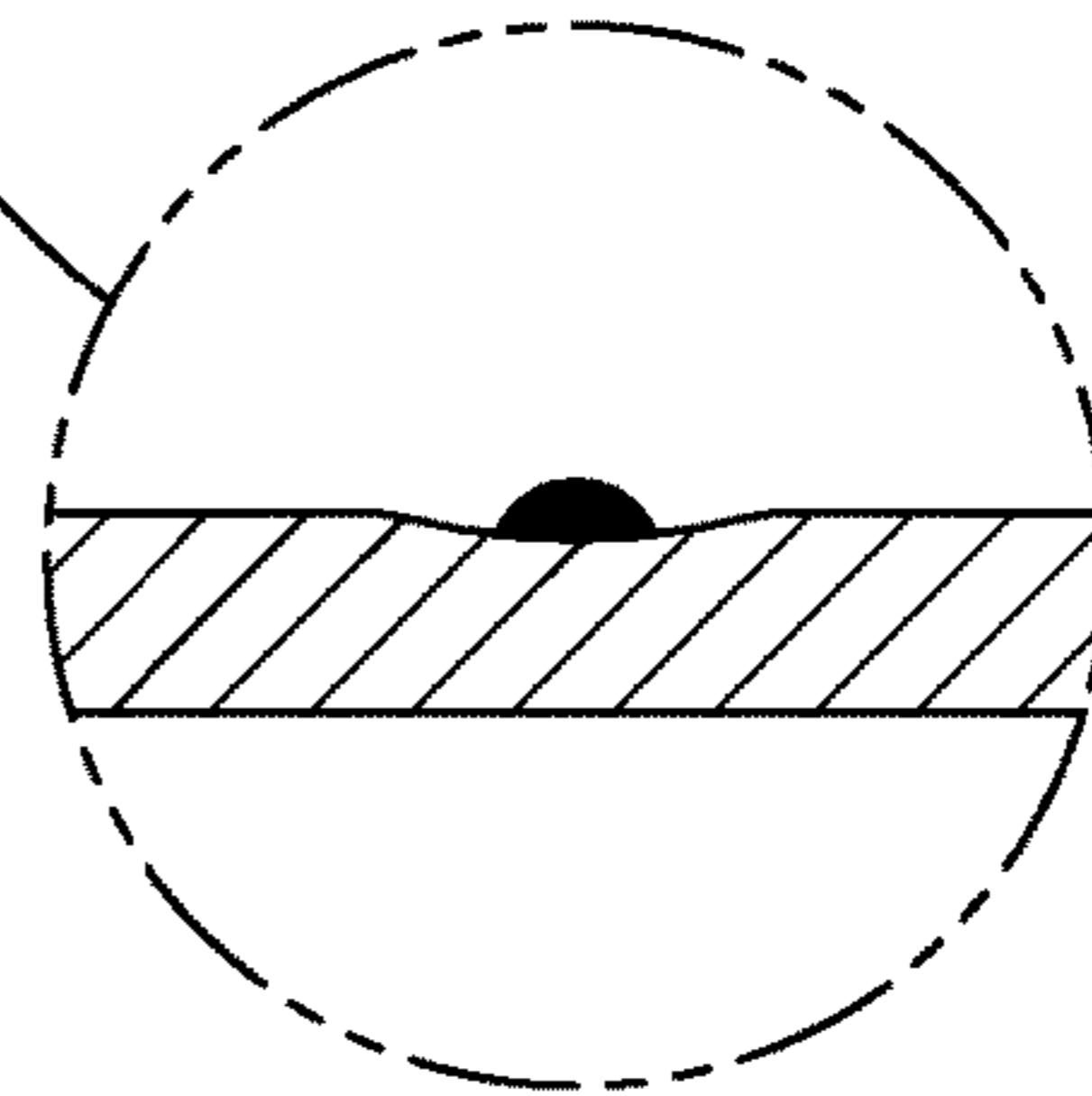

FIG. 4

FIG. 5

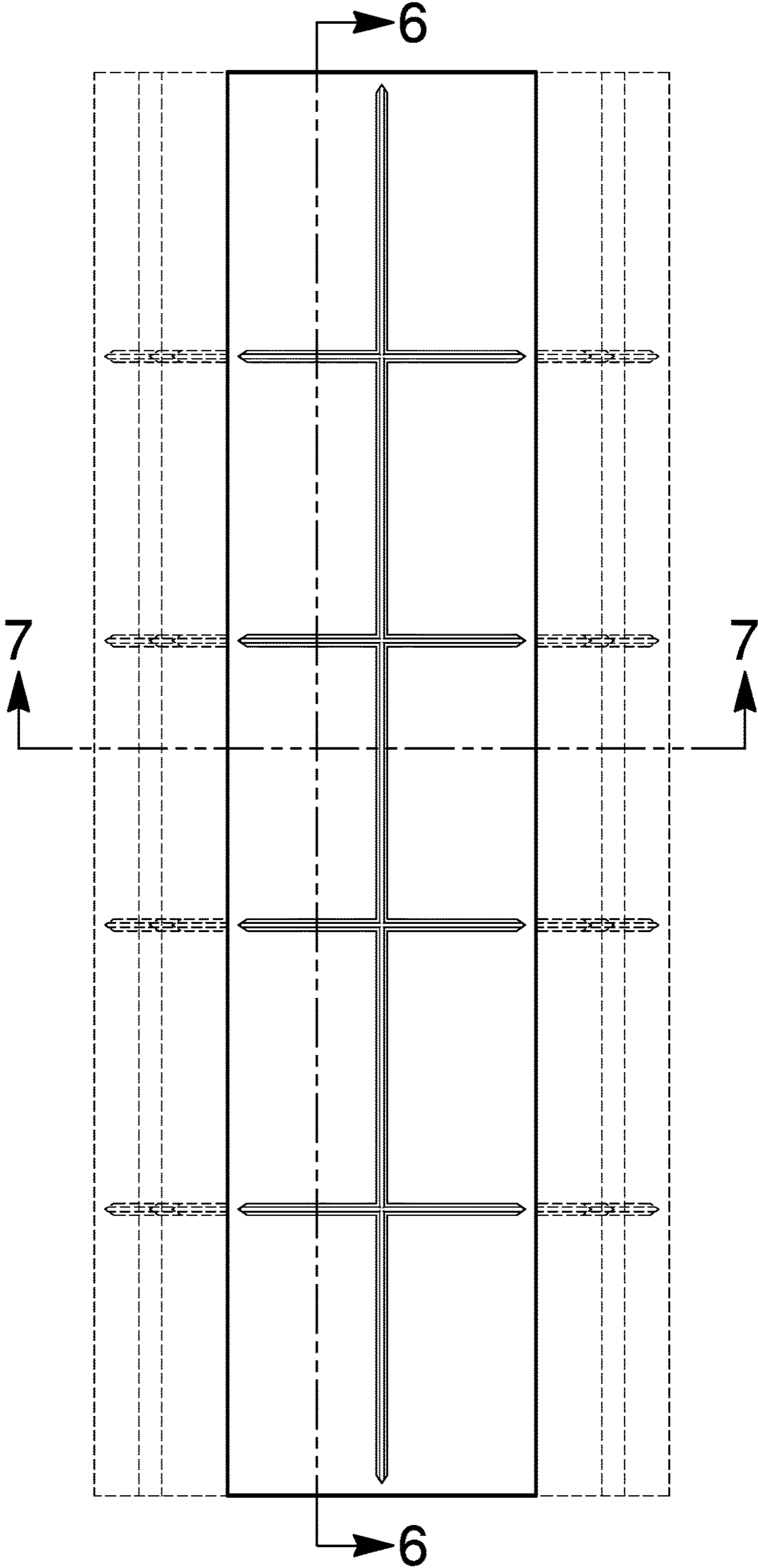

FIG. 6



FIG. 7

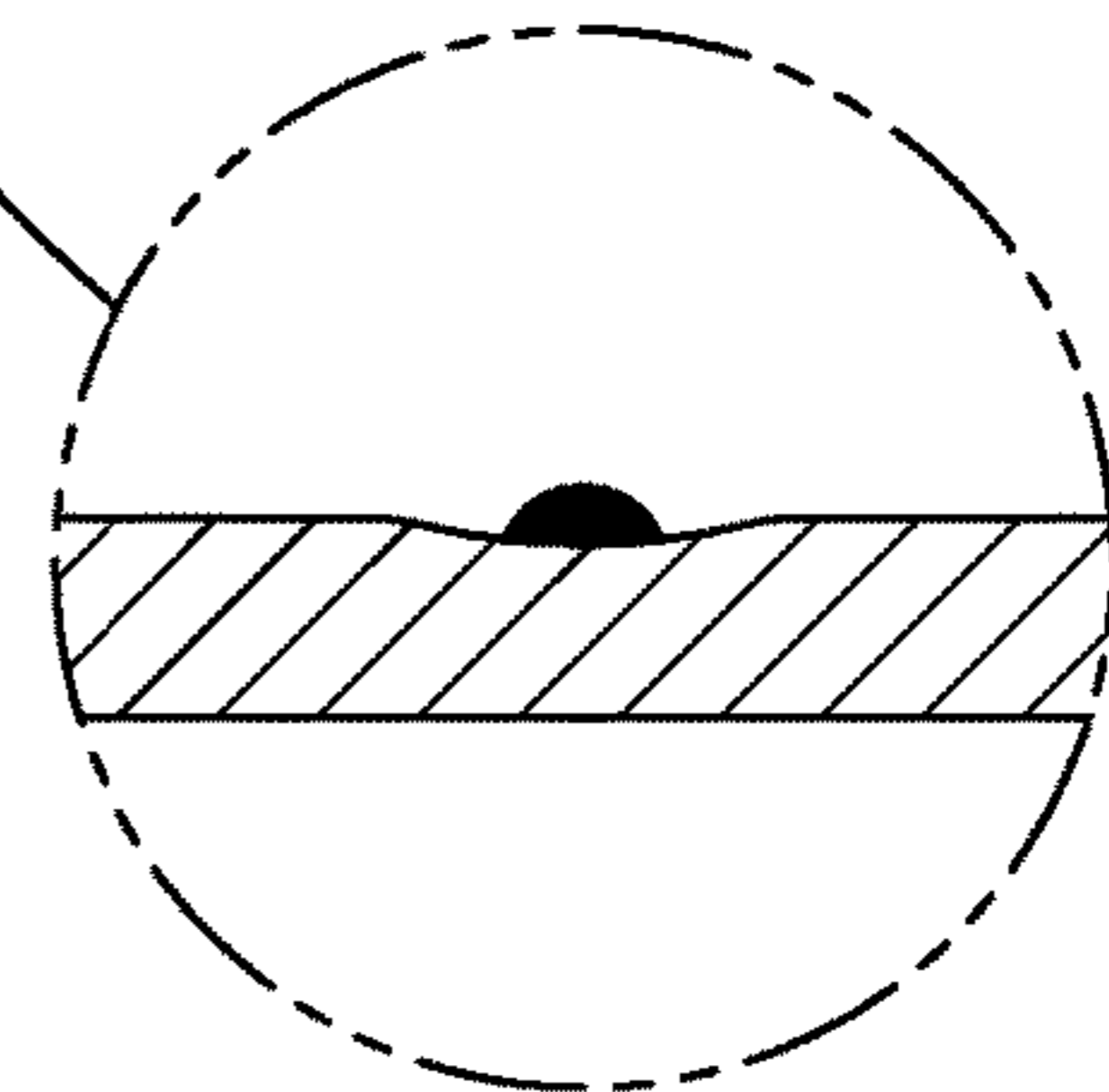

FIG. 8

FIG. 9

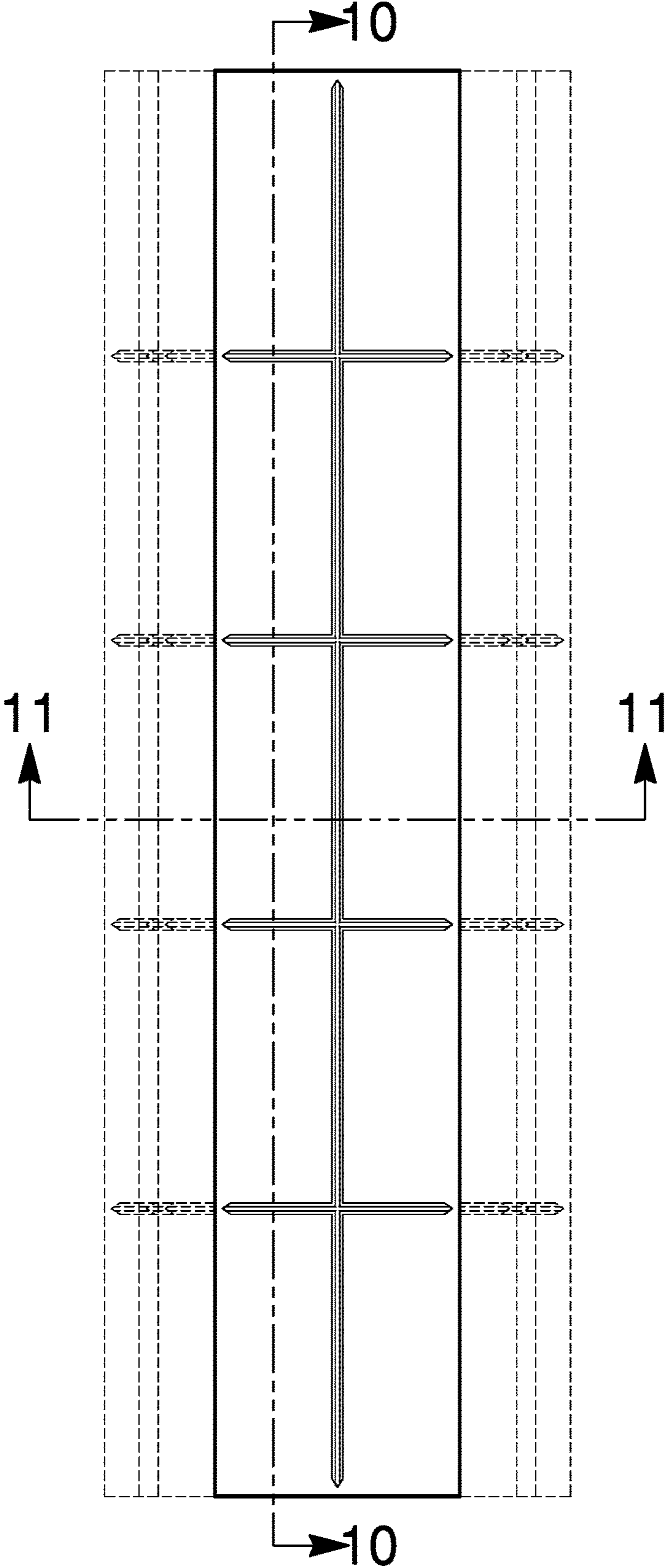

FIG. 10



FIG. 11

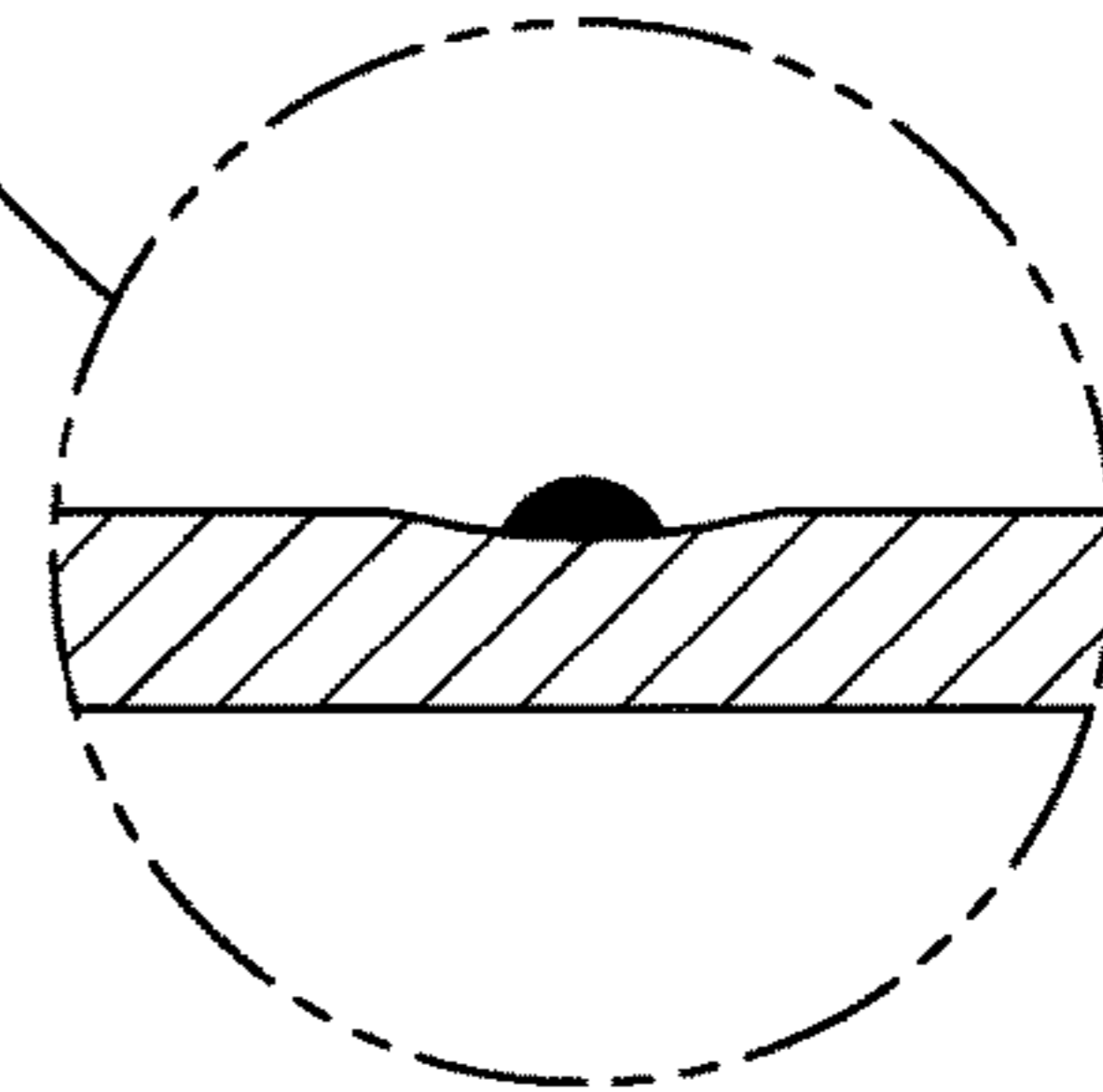
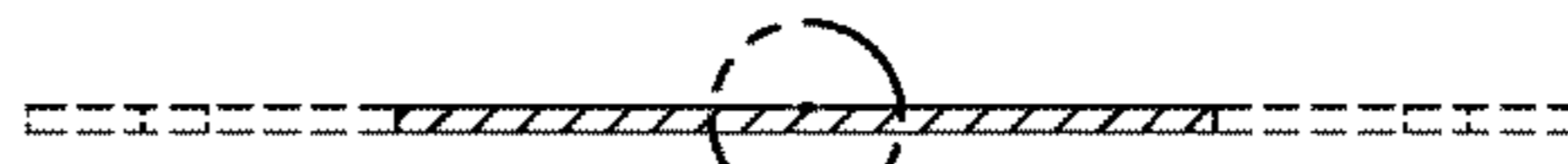

FIG. 12

FIG. 13

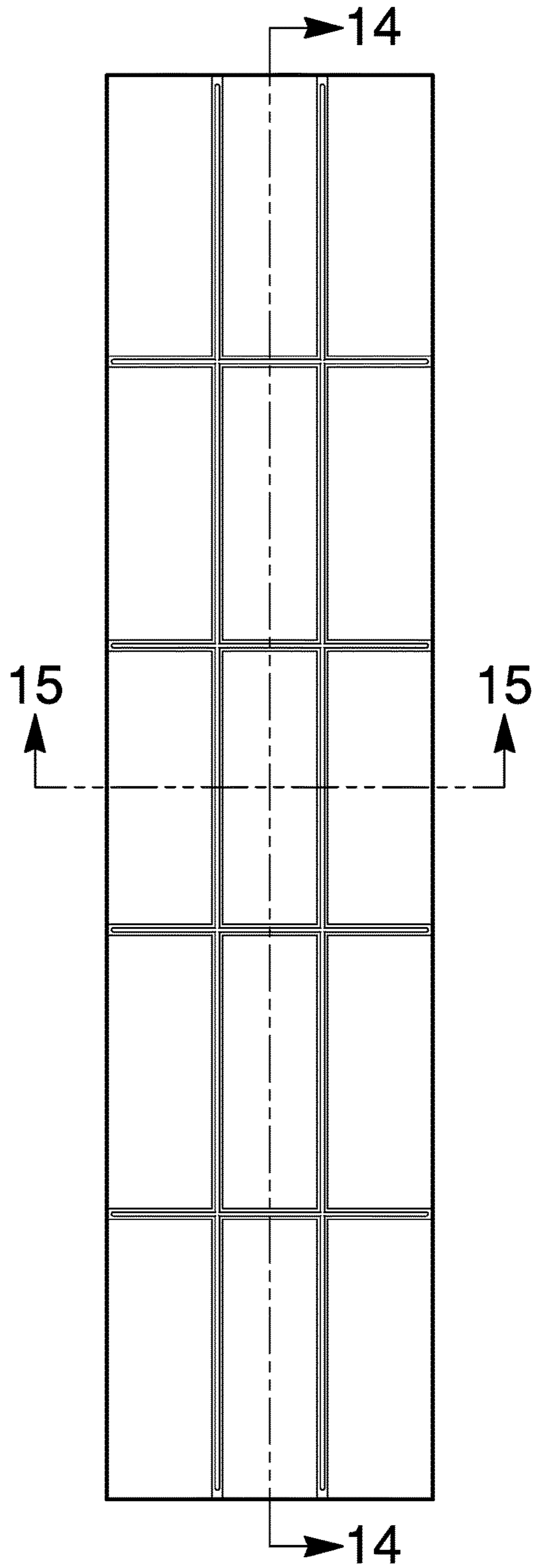

FIG. 14



FIG. 15

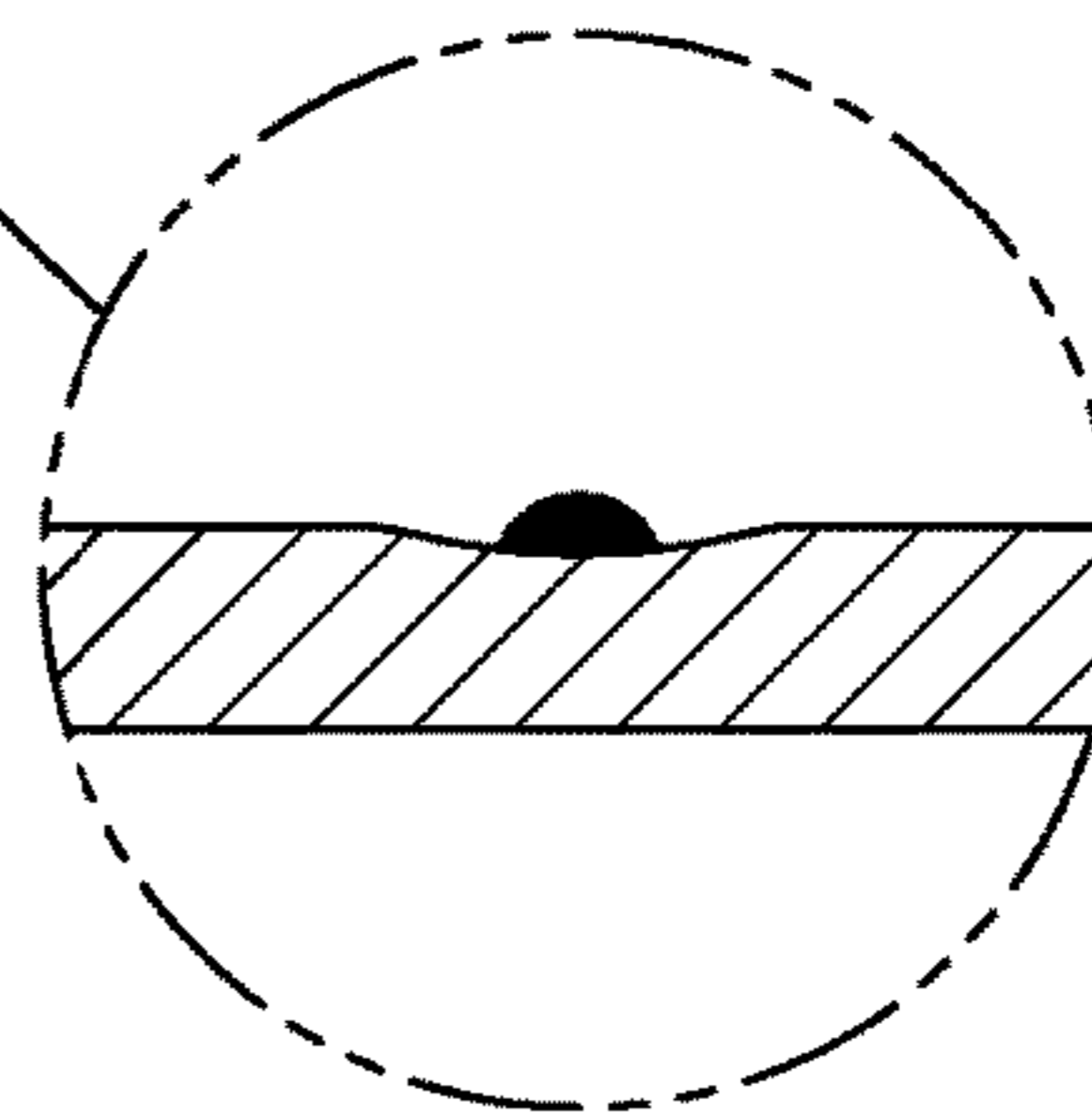
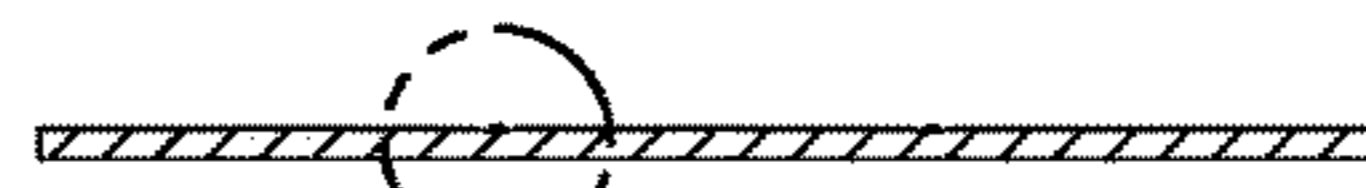

FIG. 16

FIG. 17

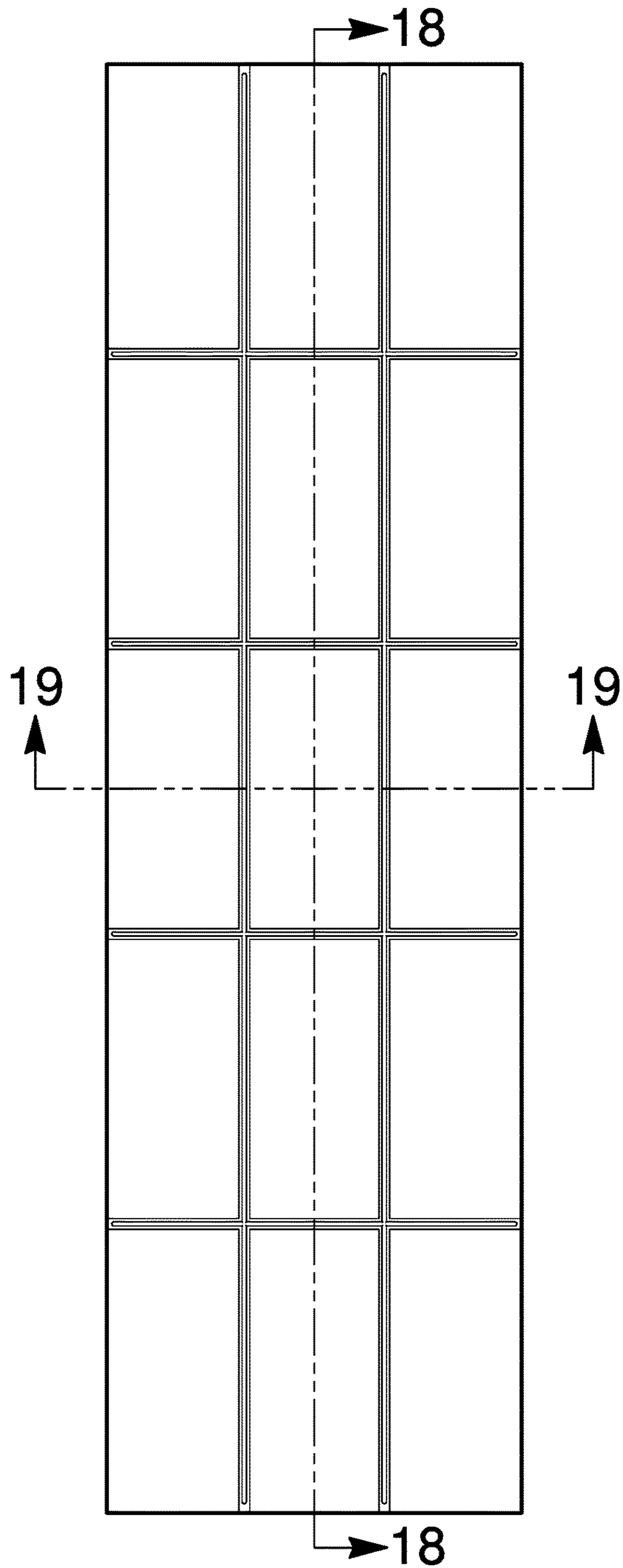

FIG. 18



FIG. 19

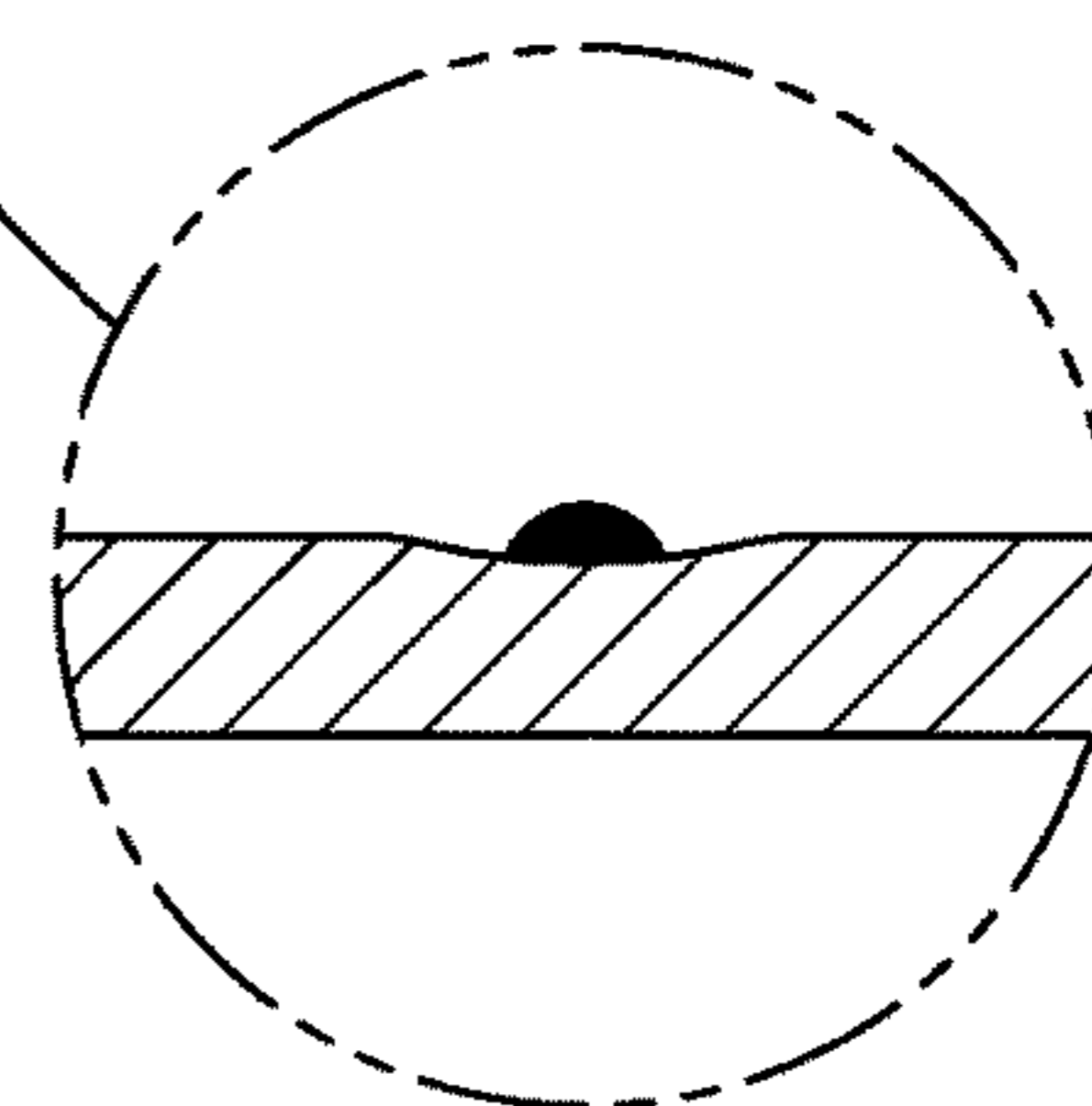
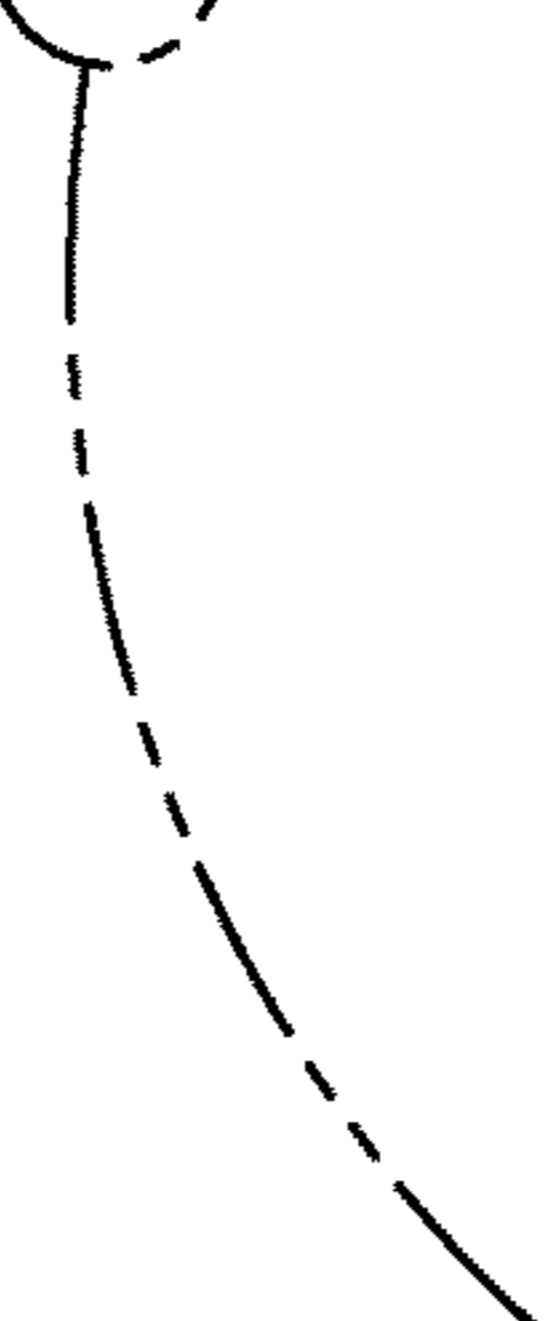

FIG. 20

FIG. 21

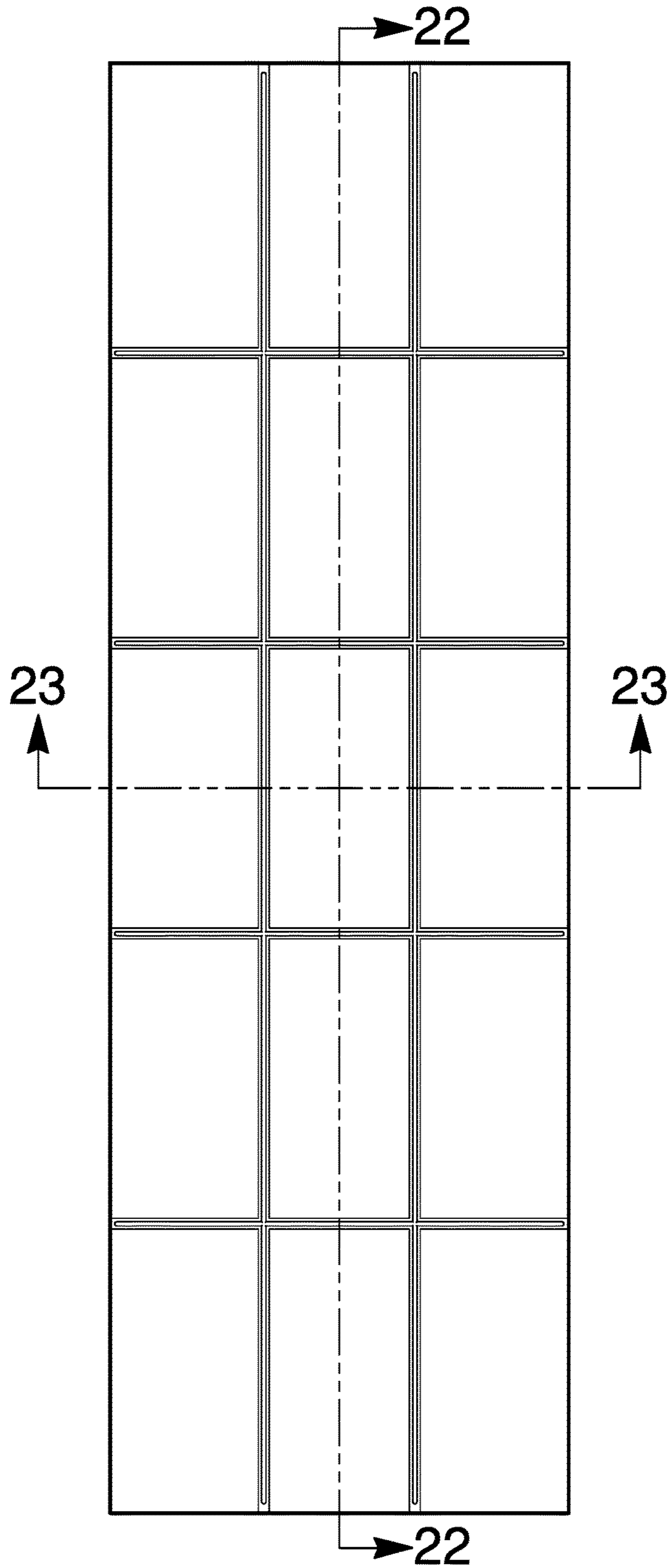

FIG. 22



FIG. 23

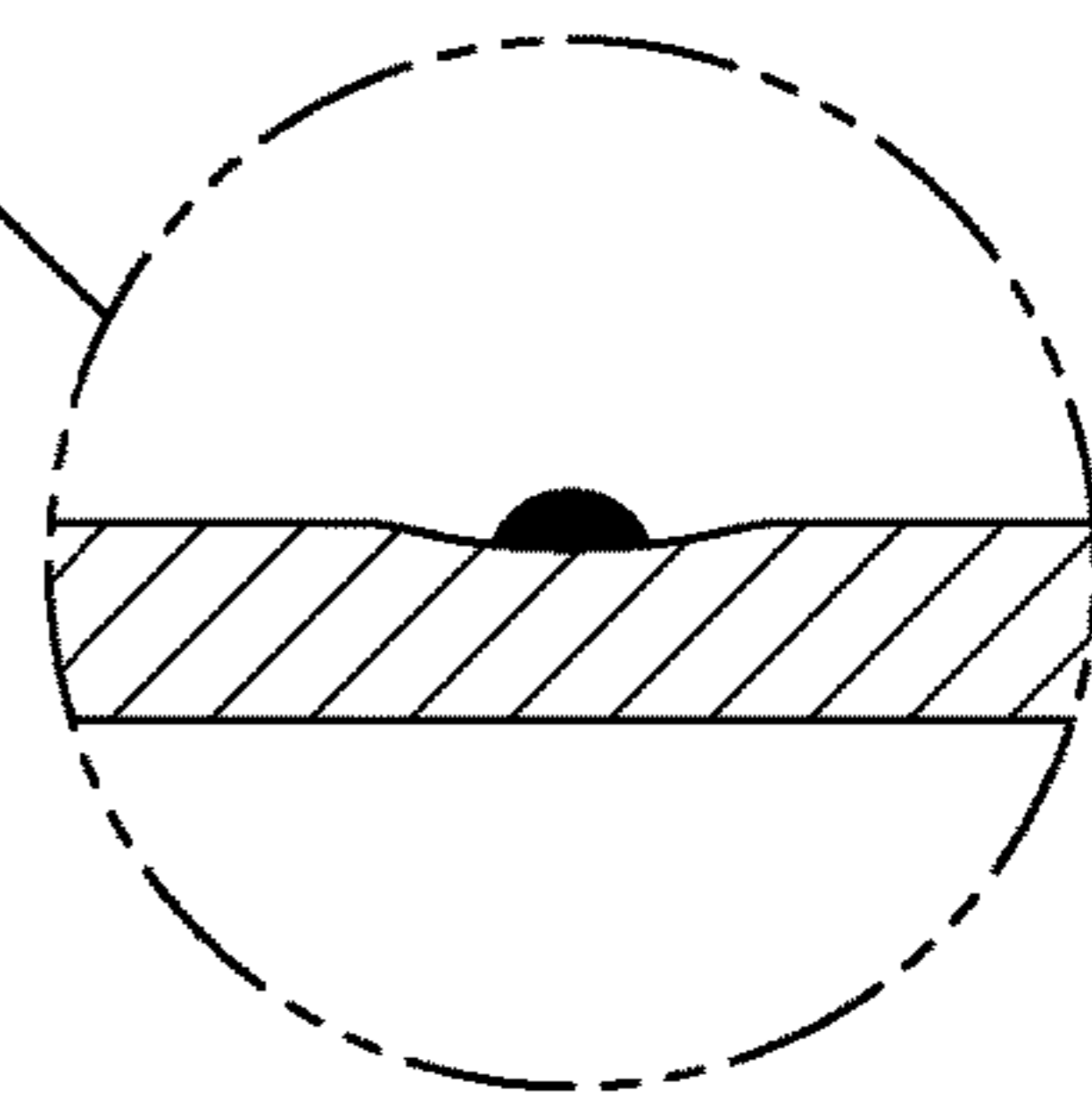
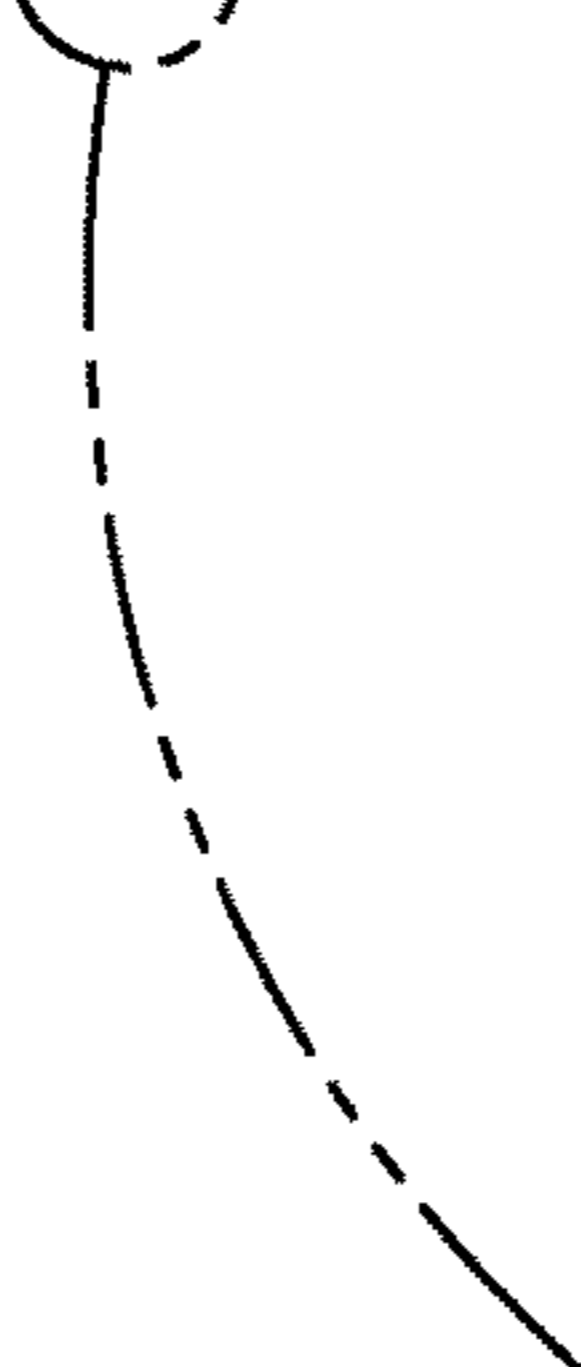
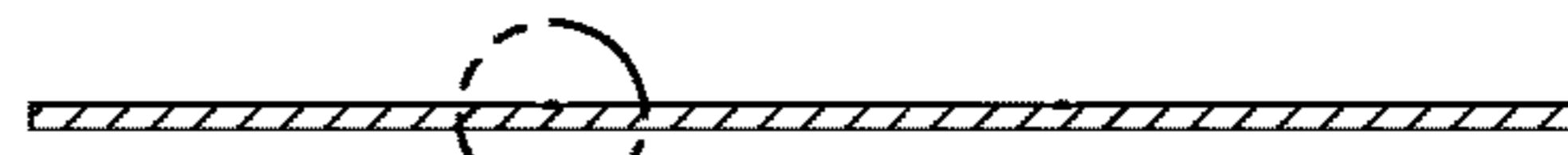

FIG. 24

FIG. 25

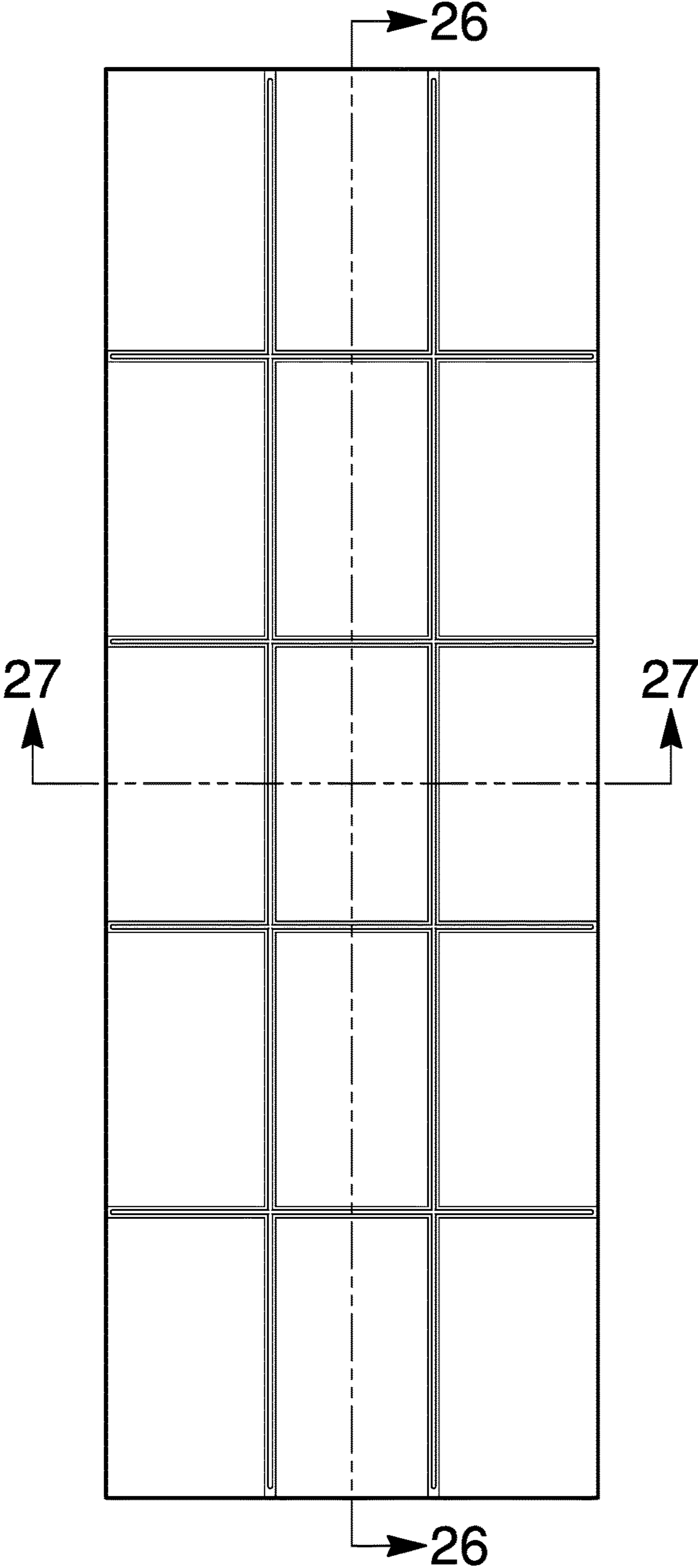

FIG. 26



FIG. 27

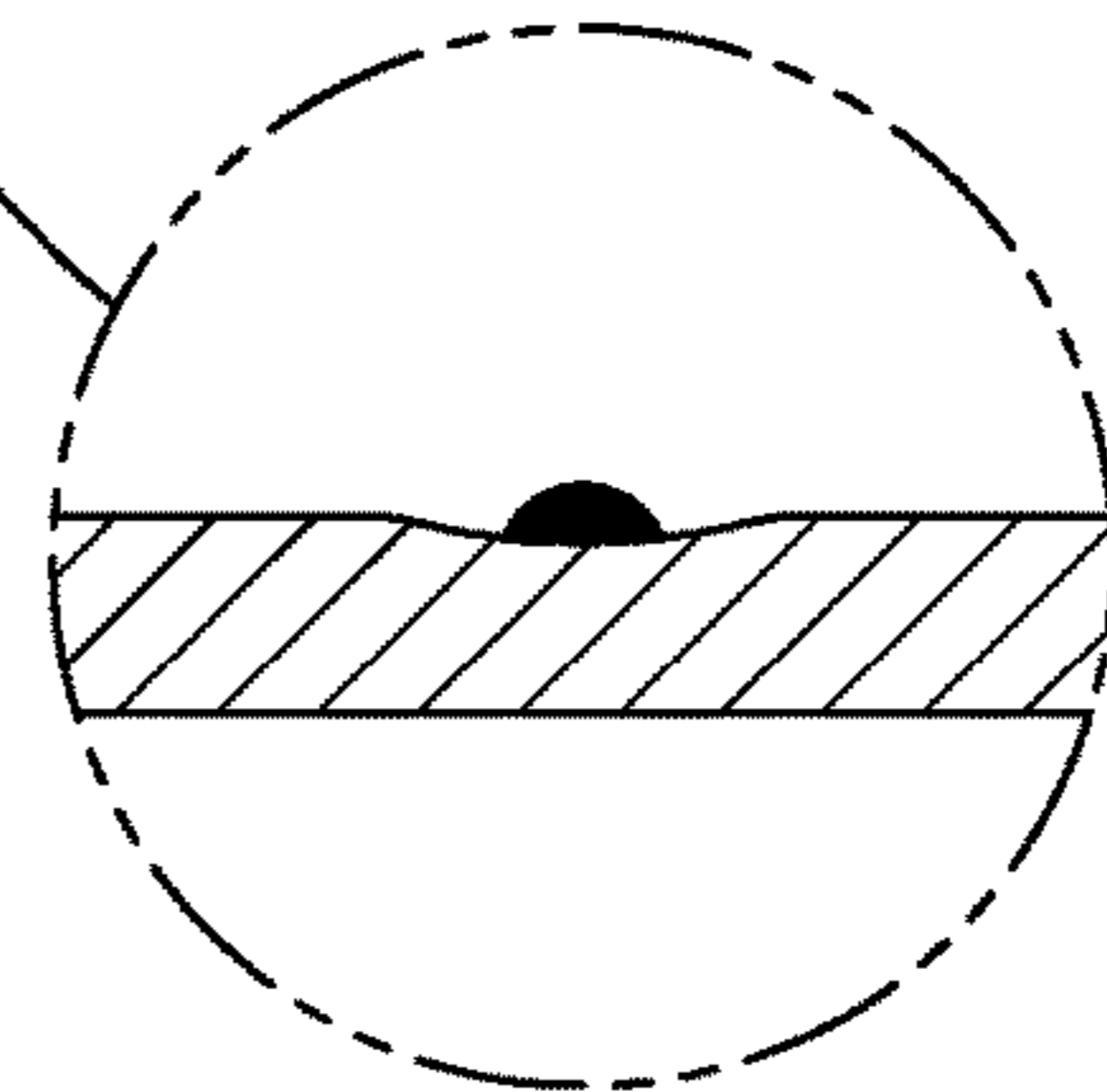

FIG. 28

FIG. 29

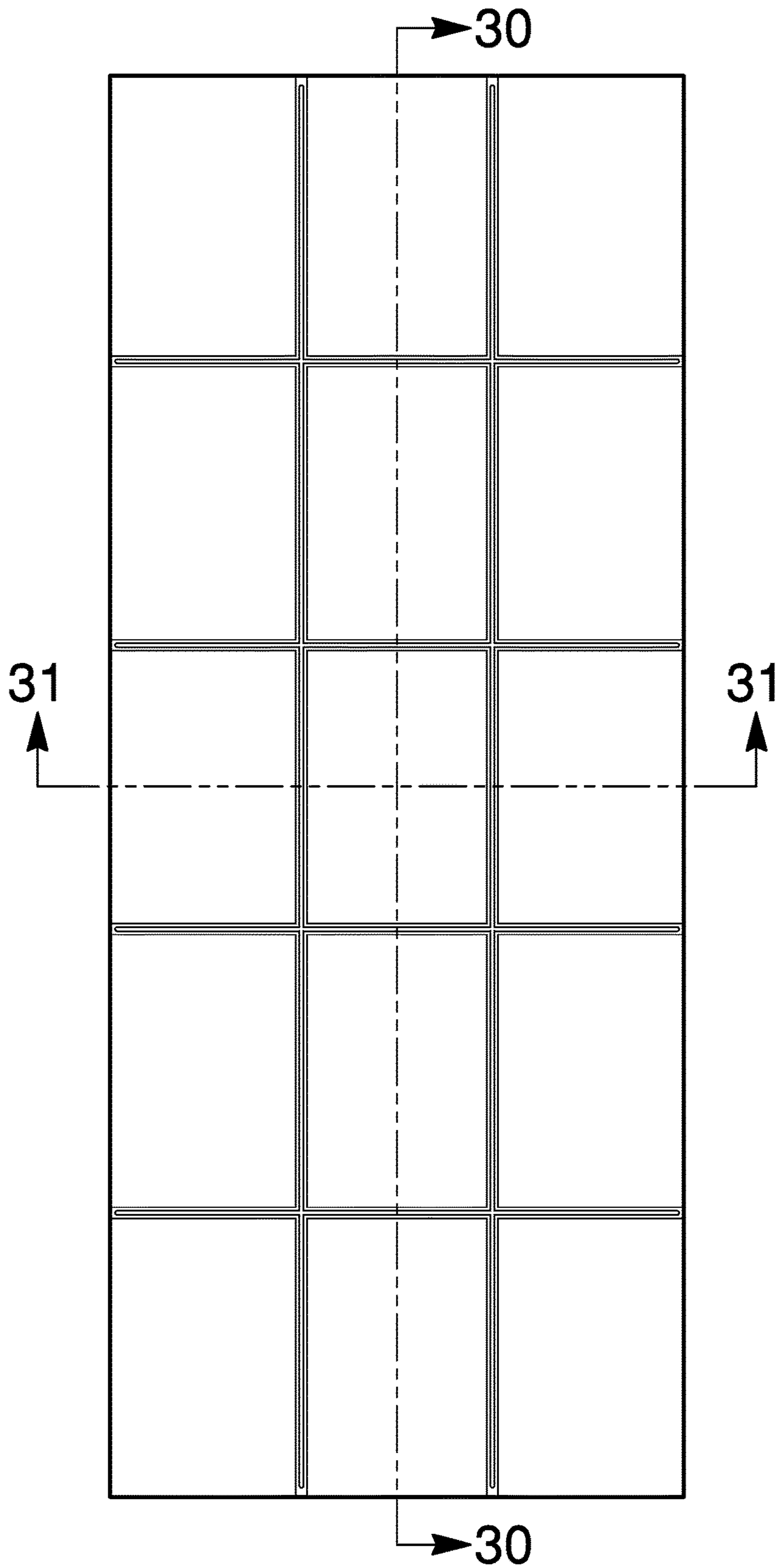

FIG. 30



FIG. 31

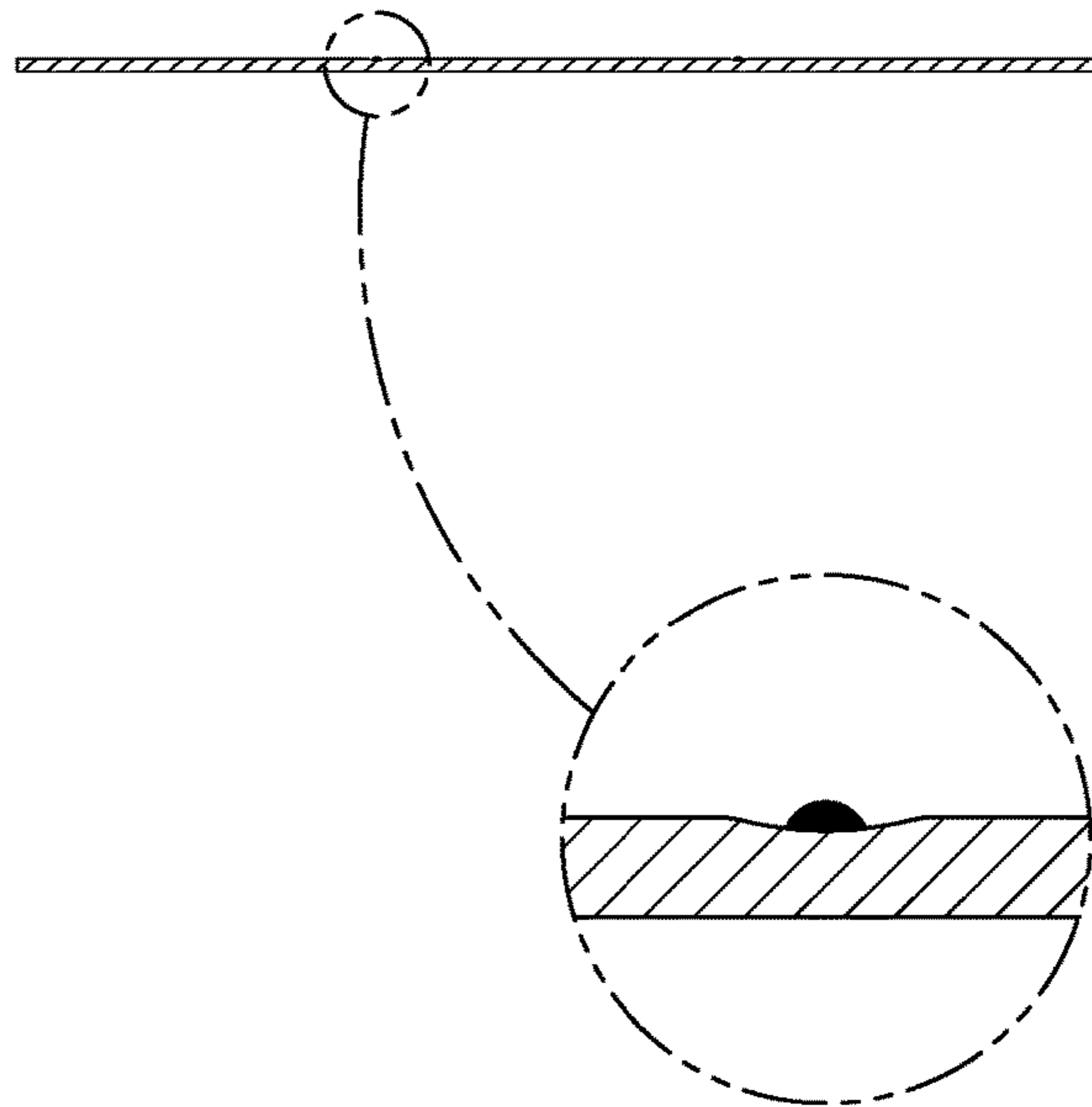

FIG. 32

FIG. 33

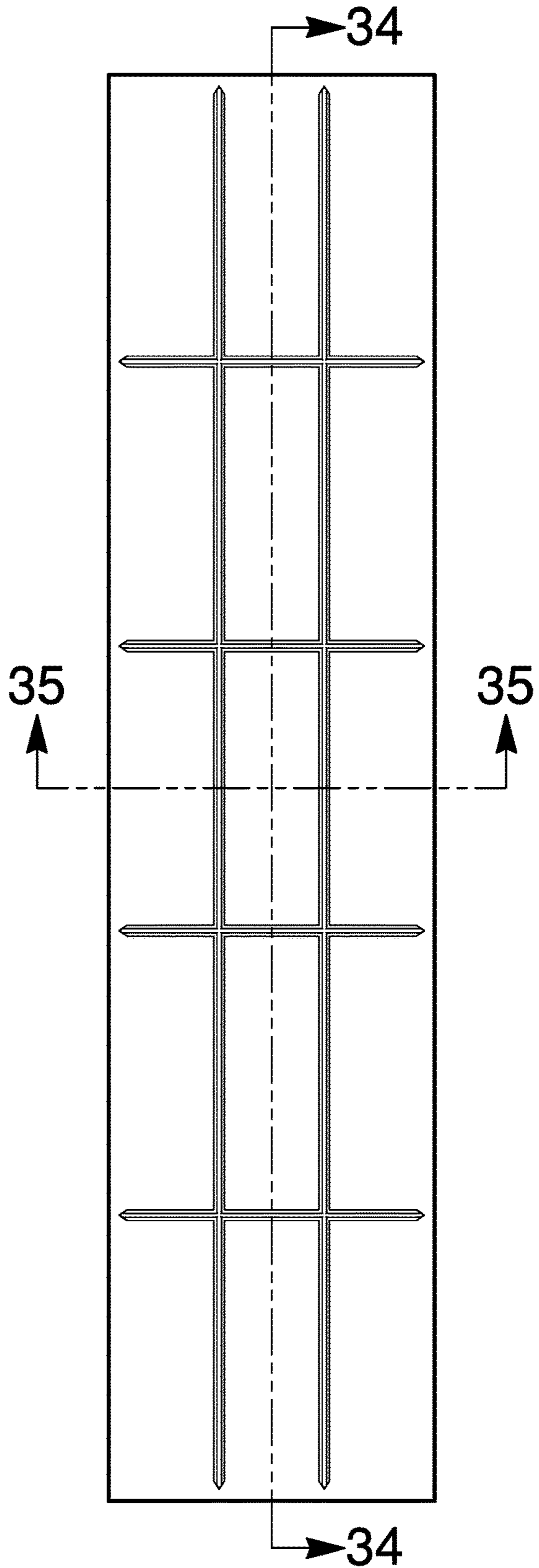

FIG. 34



FIG. 35

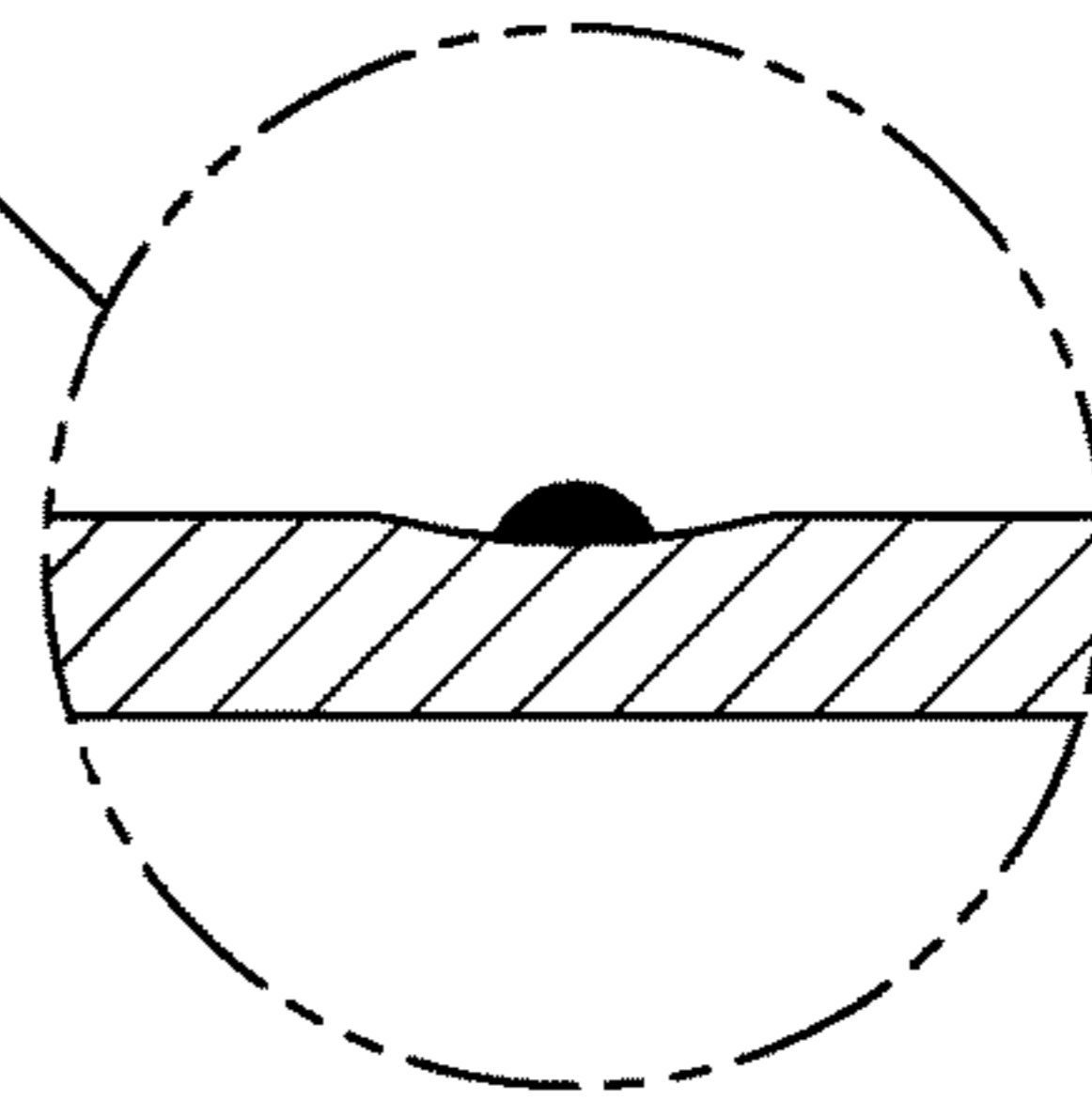
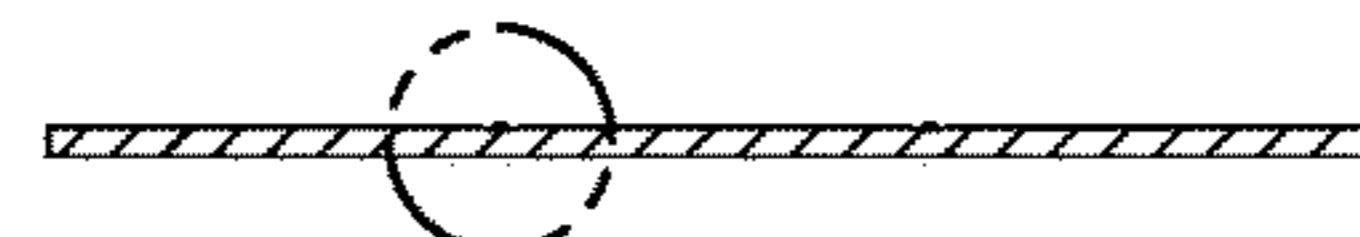

FIG. 36

FIG. 37

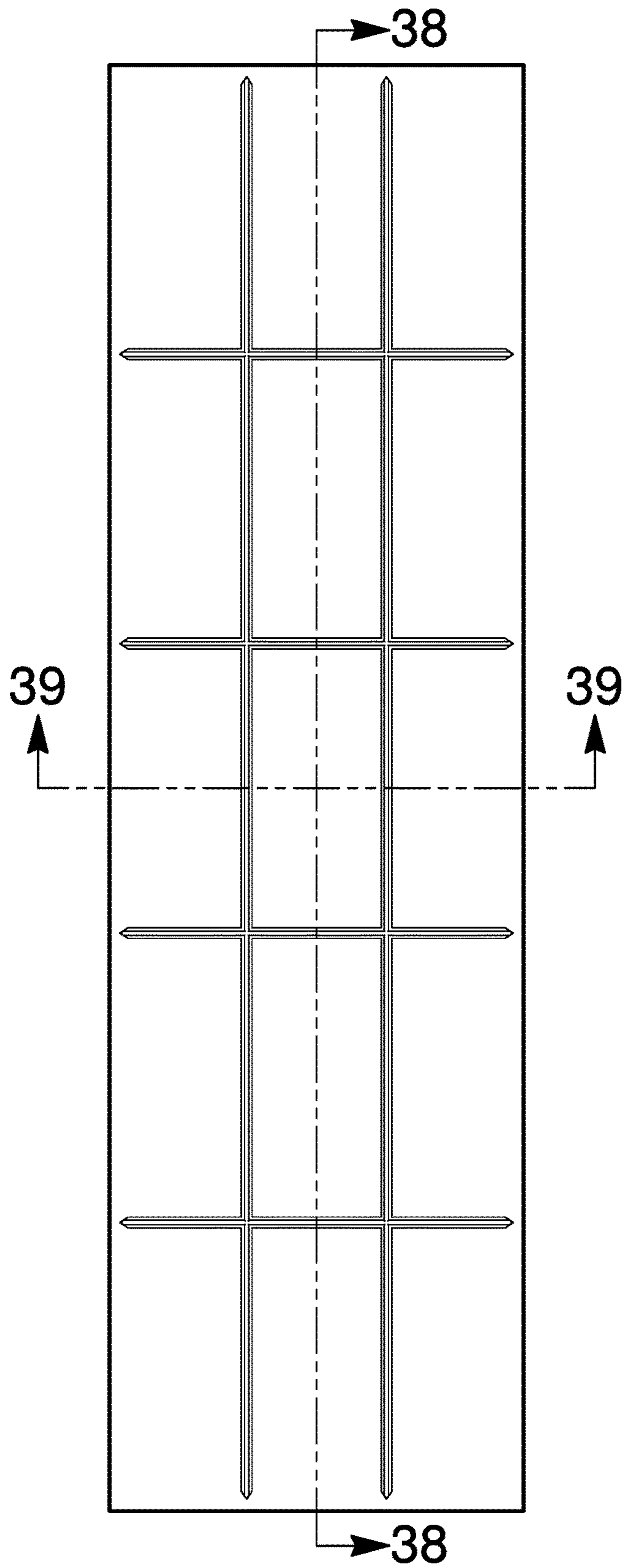

FIG. 38



FIG. 39

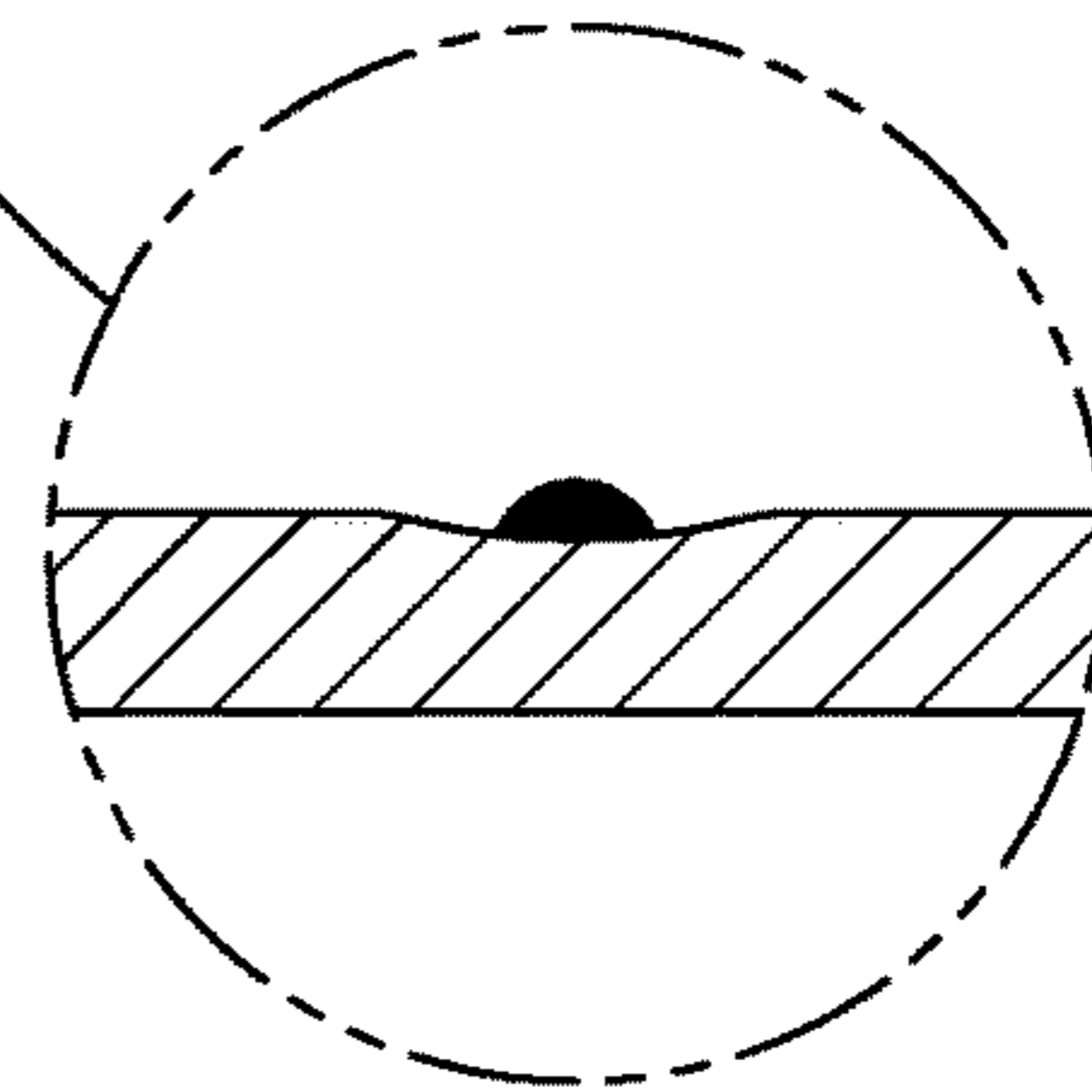
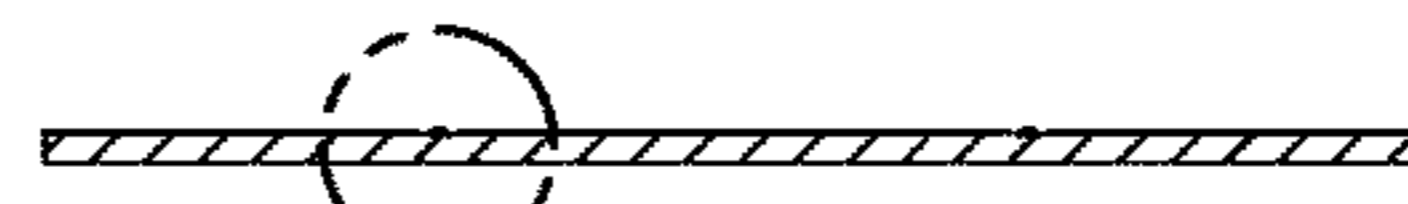

FIG. 40

FIG. 41

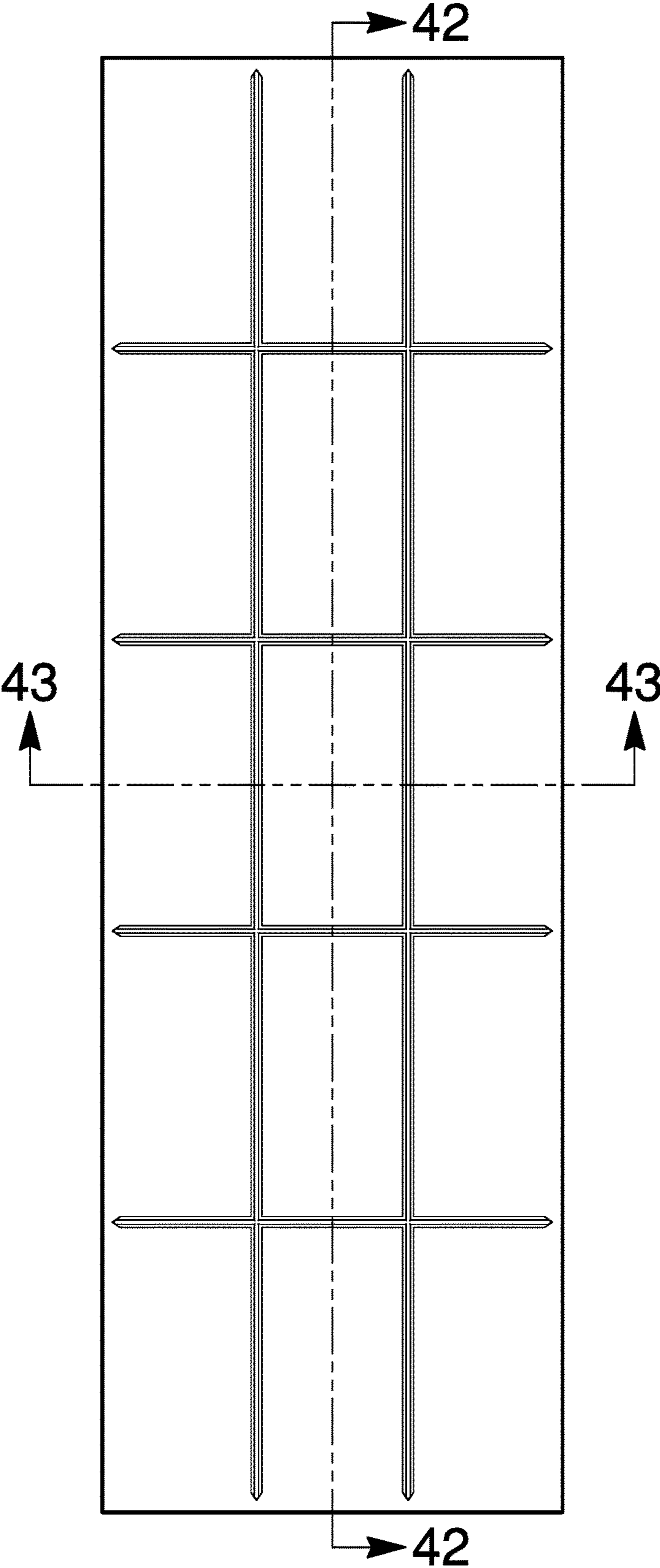

FIG. 42



FIG. 43

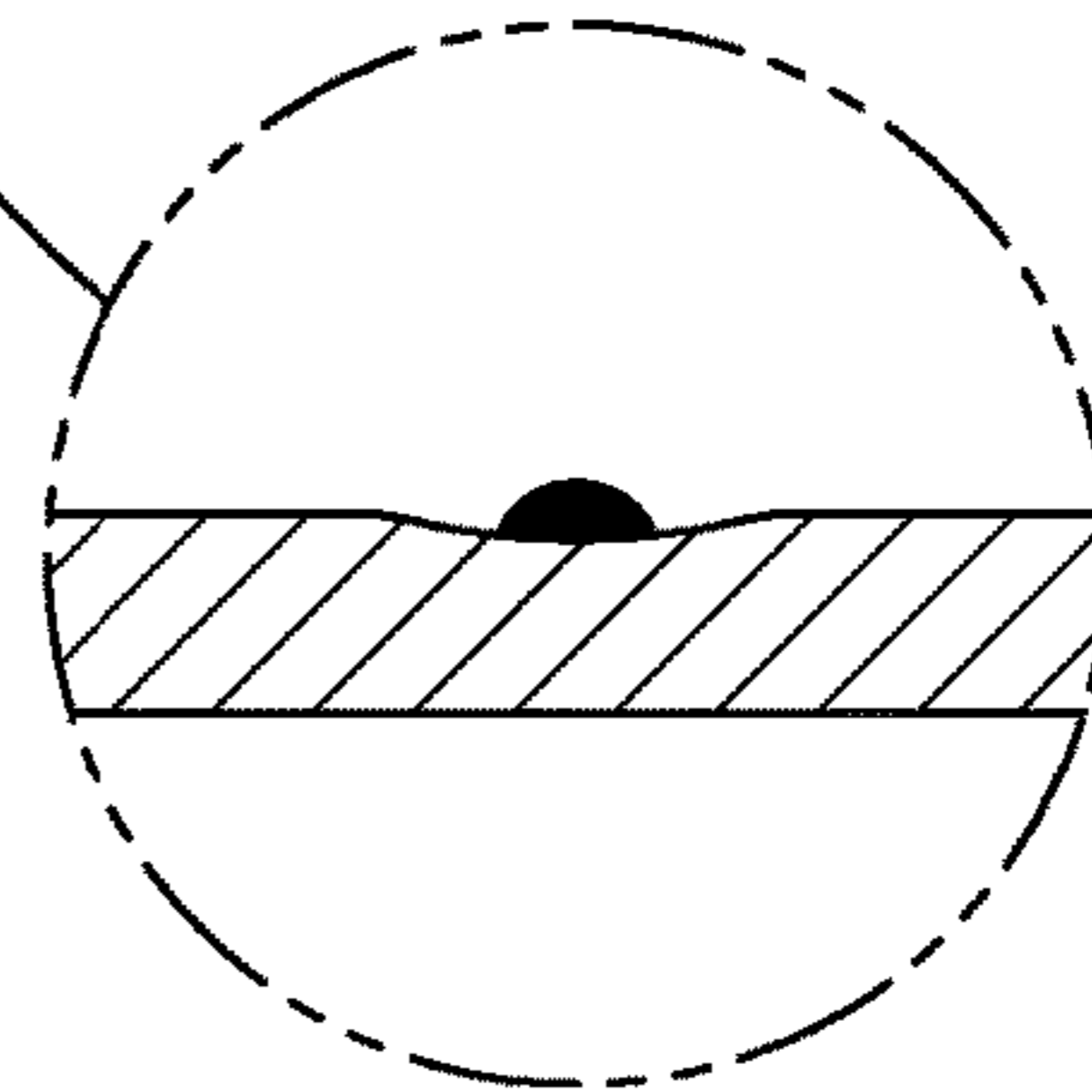
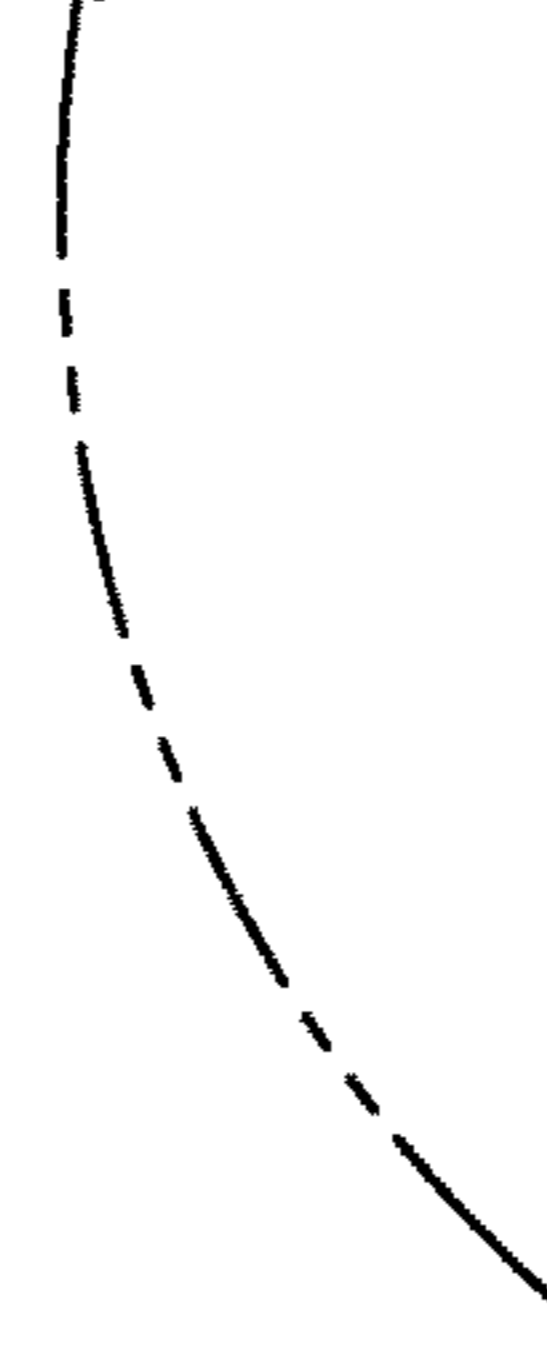
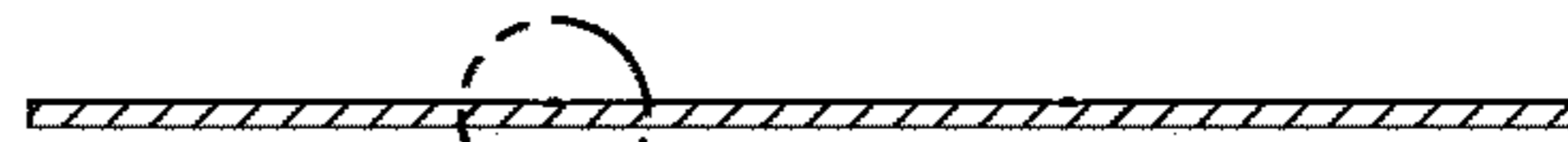

FIG. 44

FIG. 45

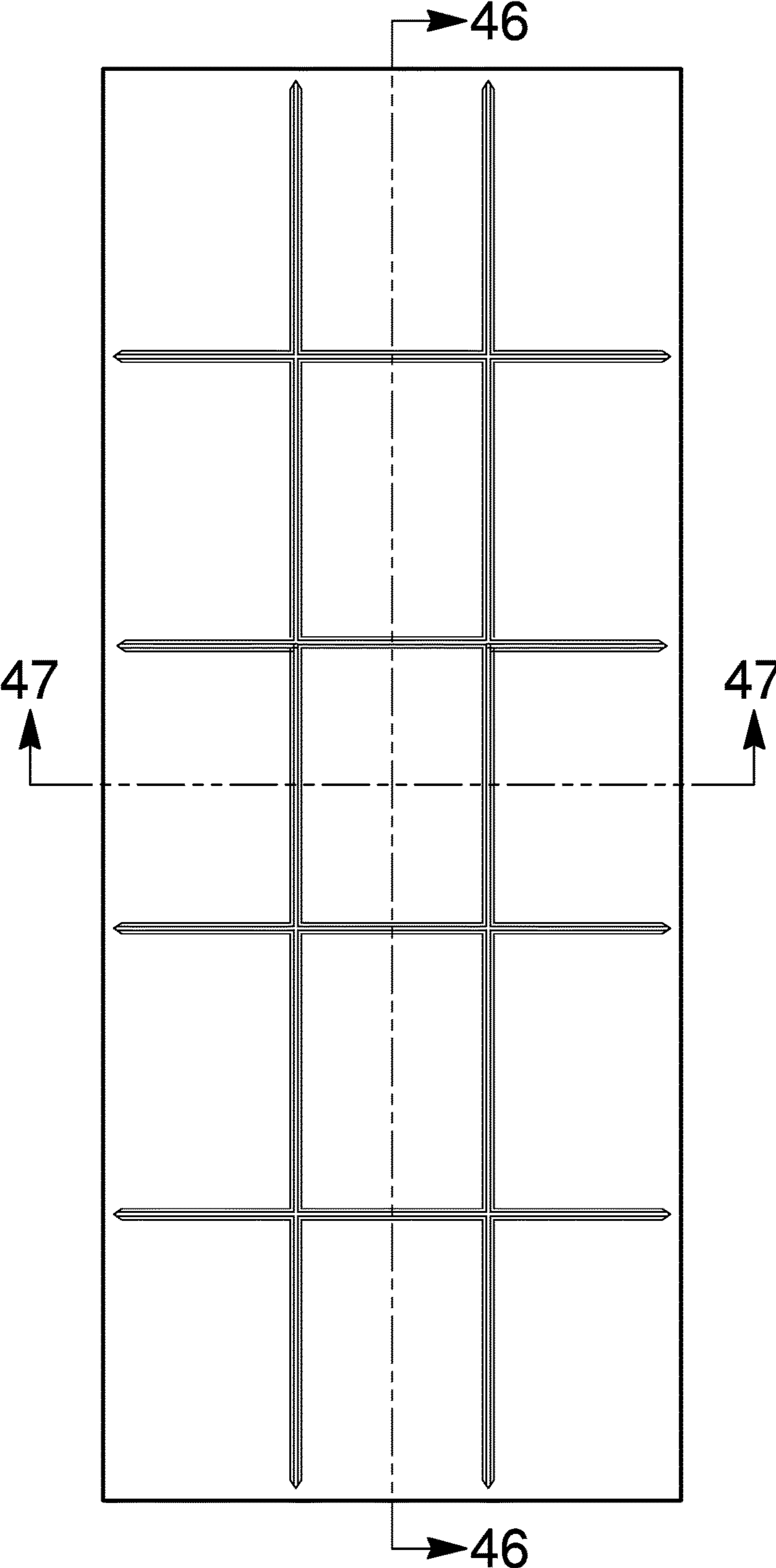

FIG. 46



FIG. 47

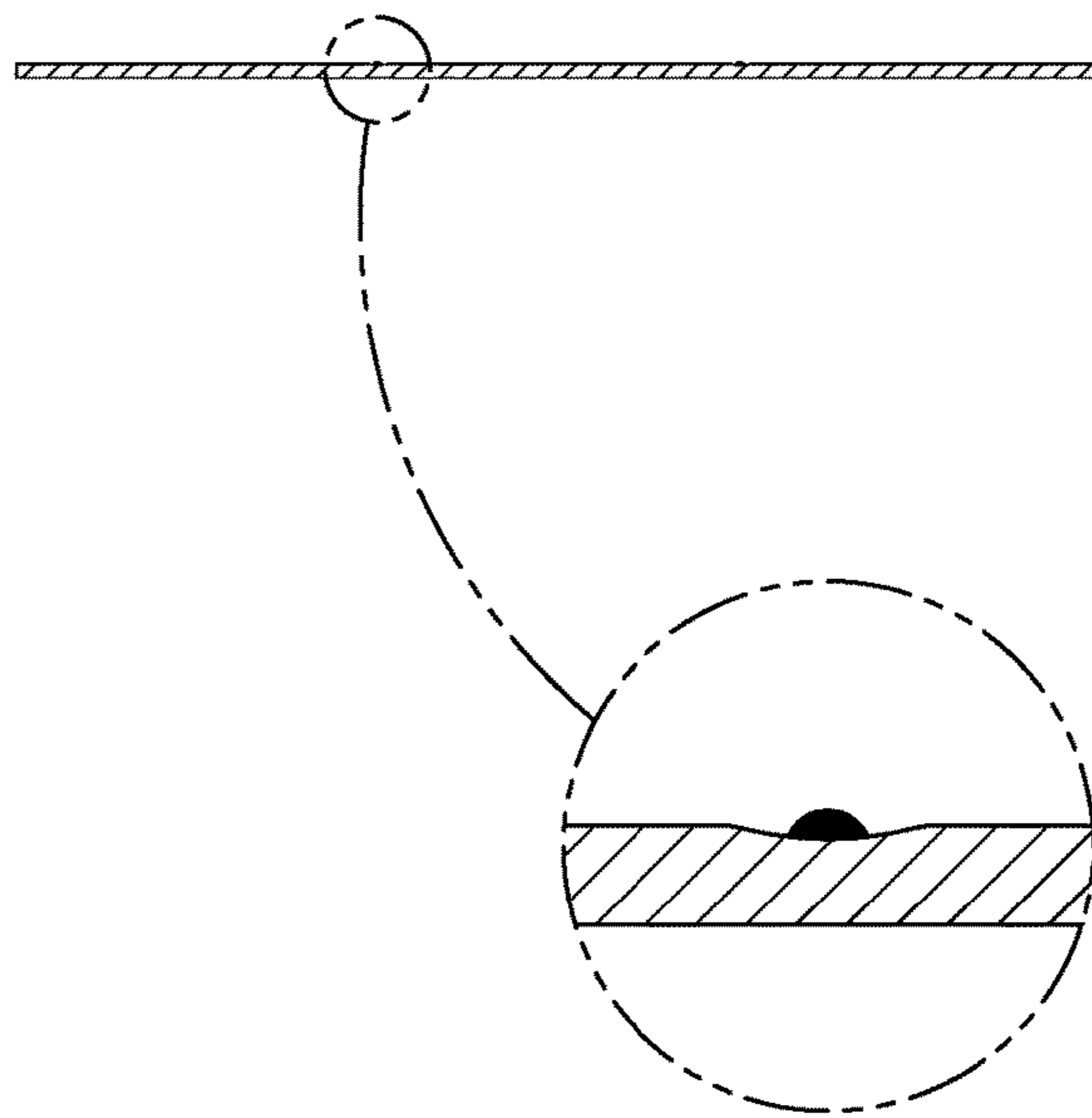

FIG. 48

FIG. 49

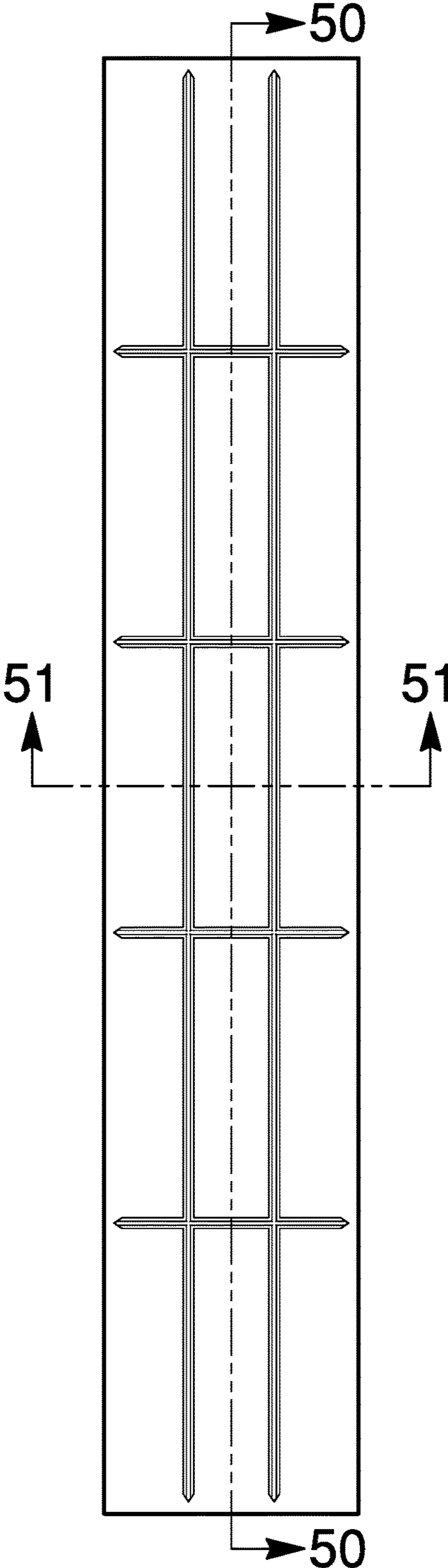

FIG. 50



FIG. 51

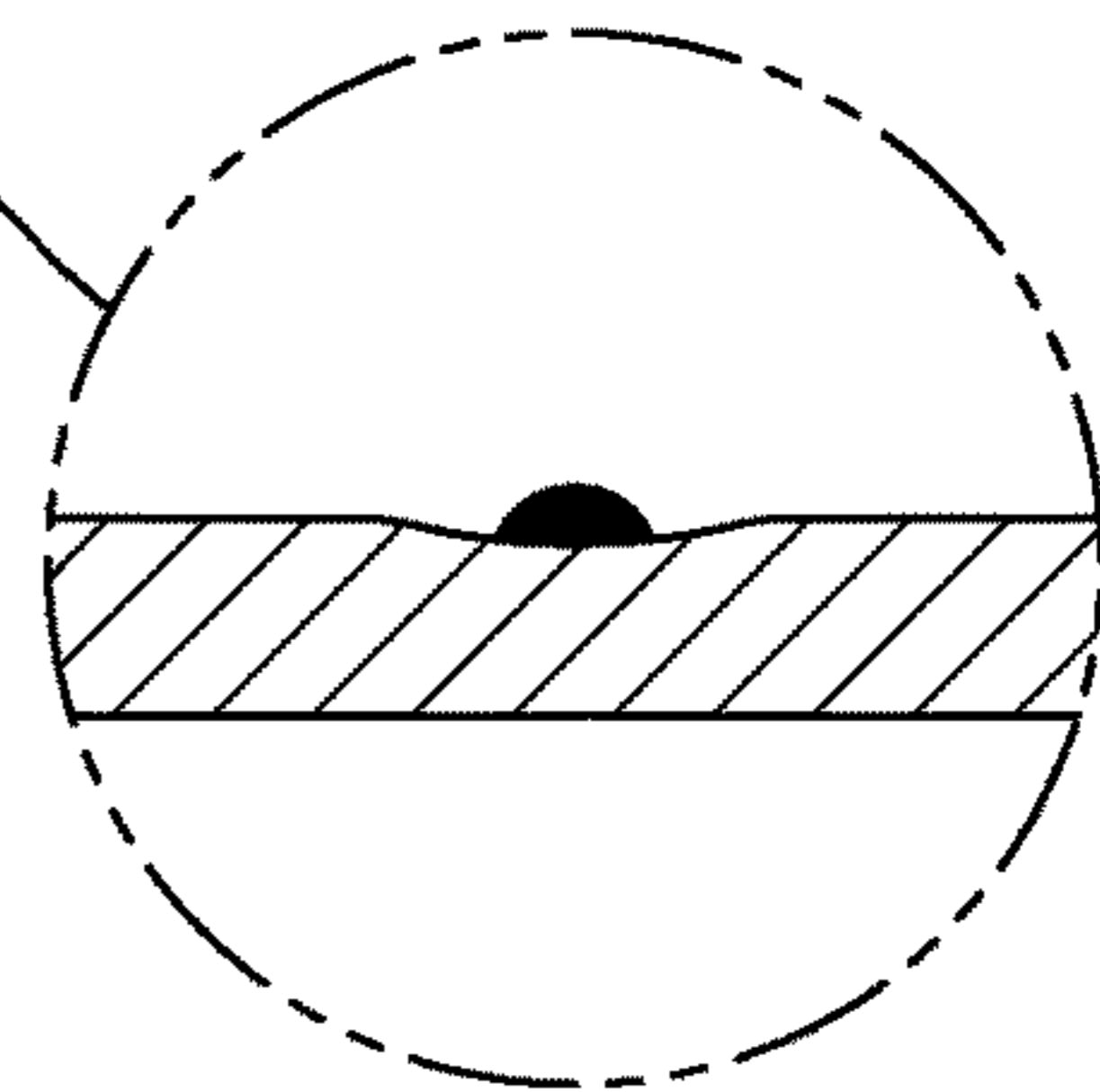

FIG. 52

FIG. 53

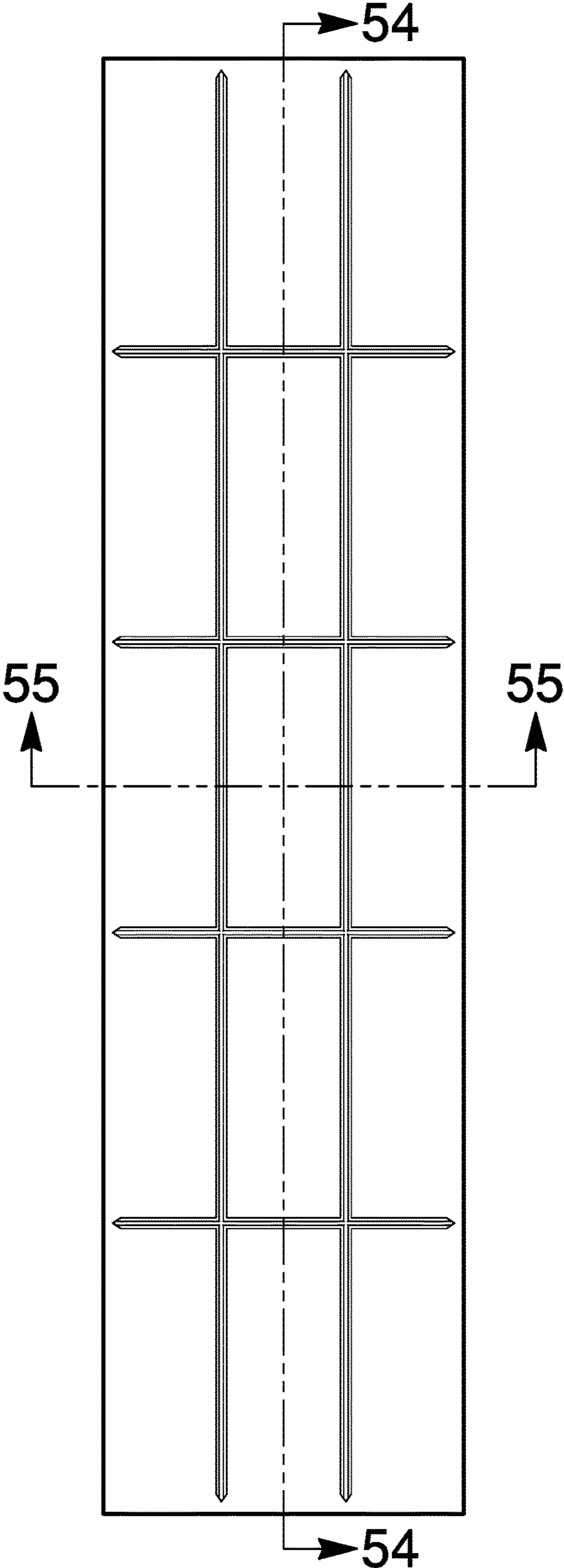

FIG. 54



FIG. 55

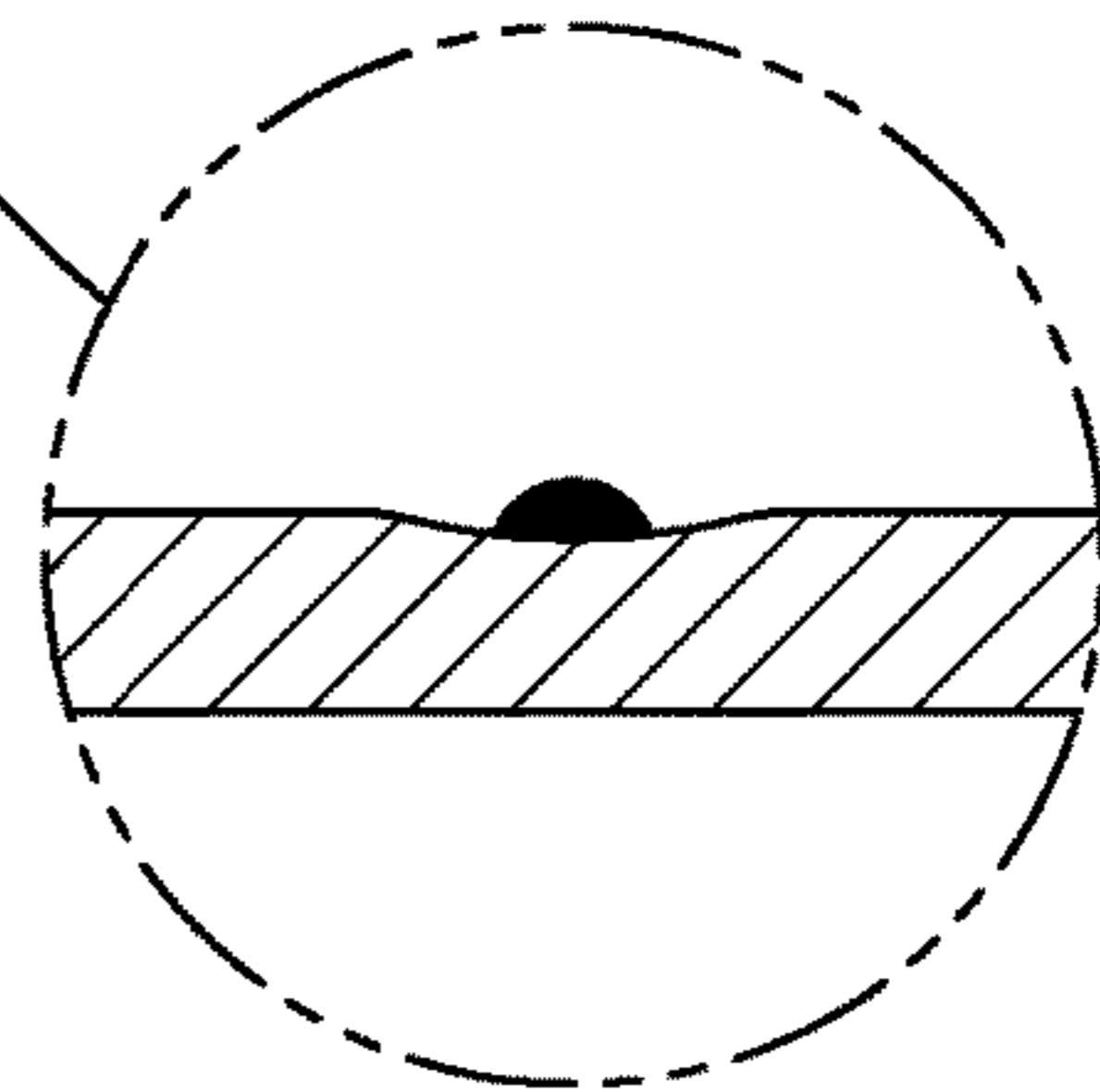
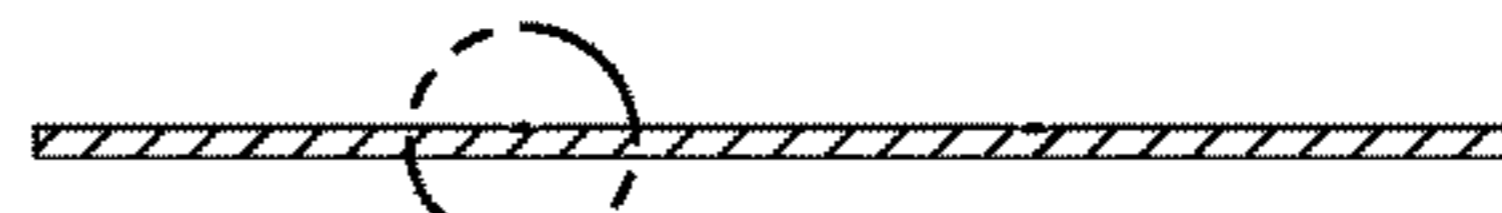

FIG. 56

FIG. 57

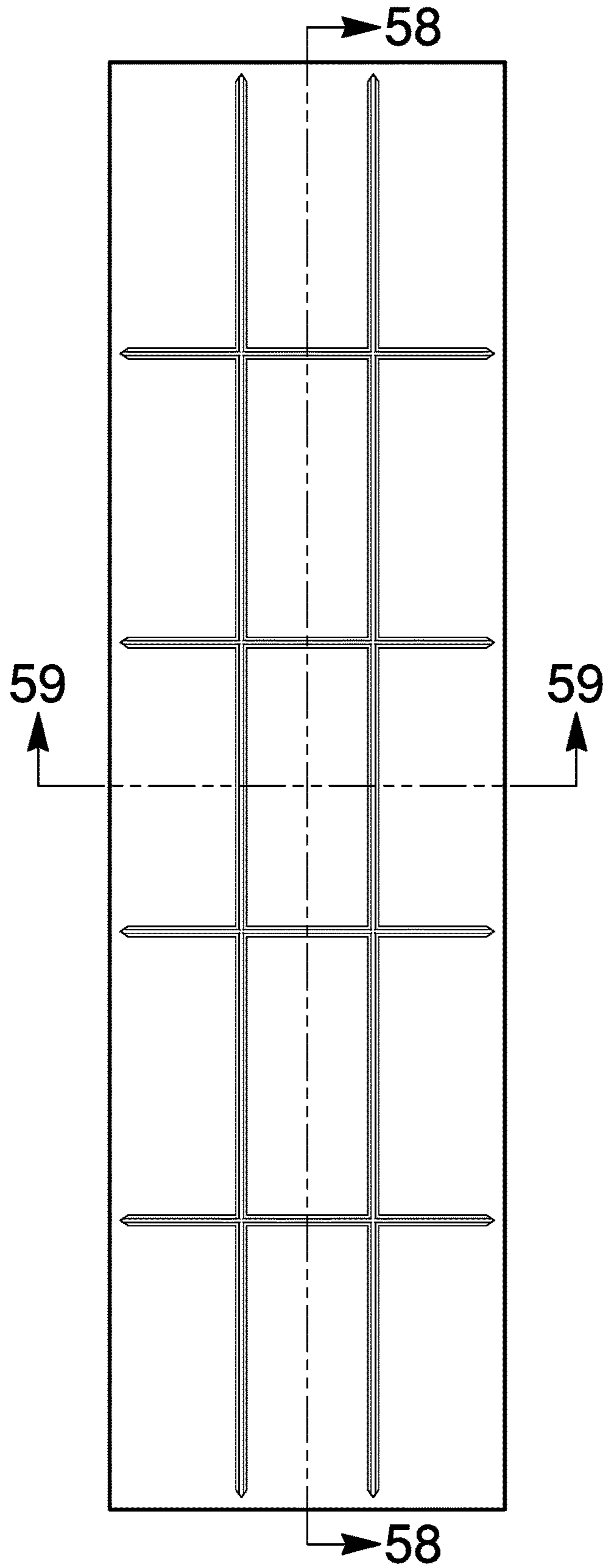

FIG. 58



FIG. 59

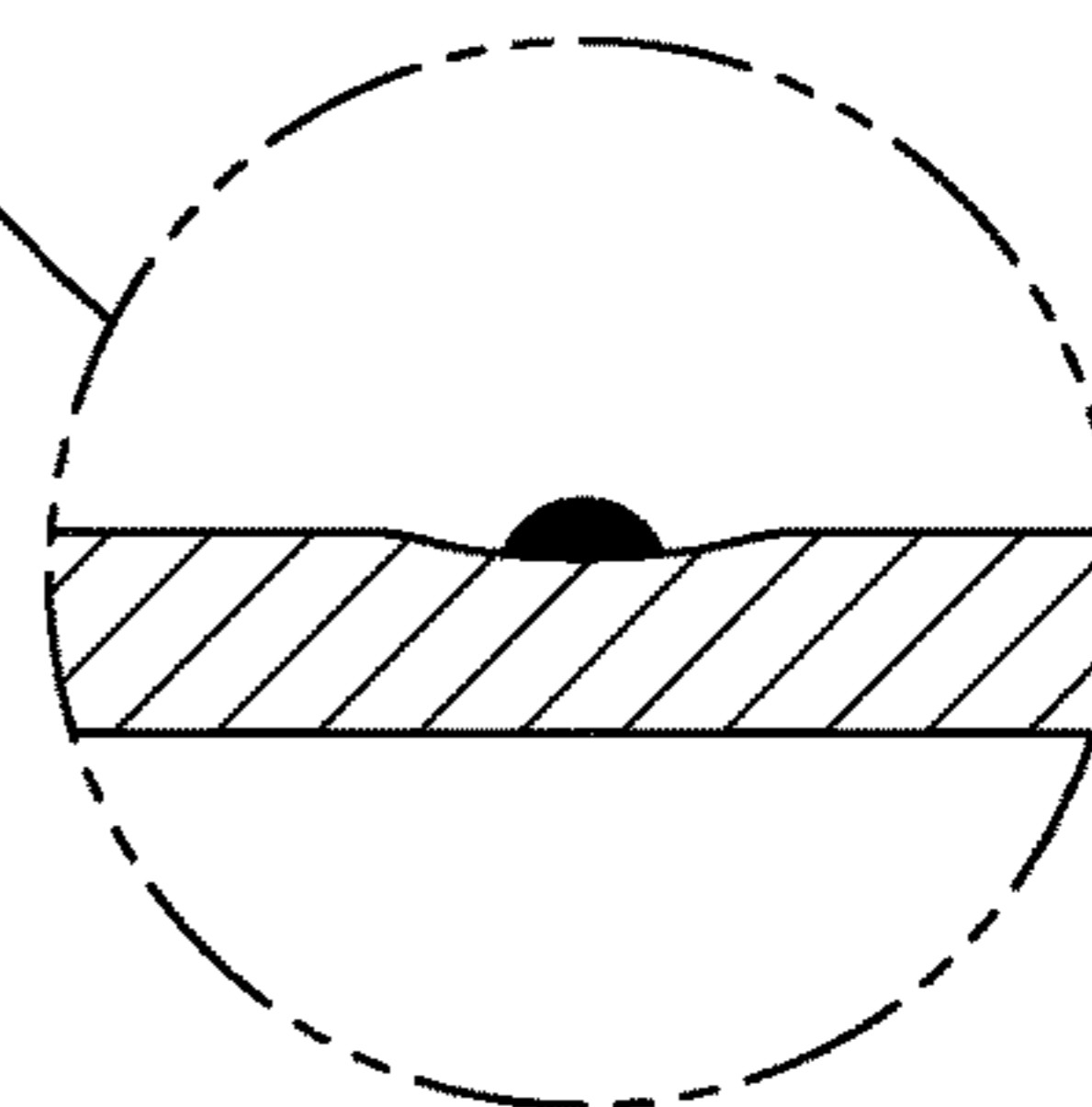
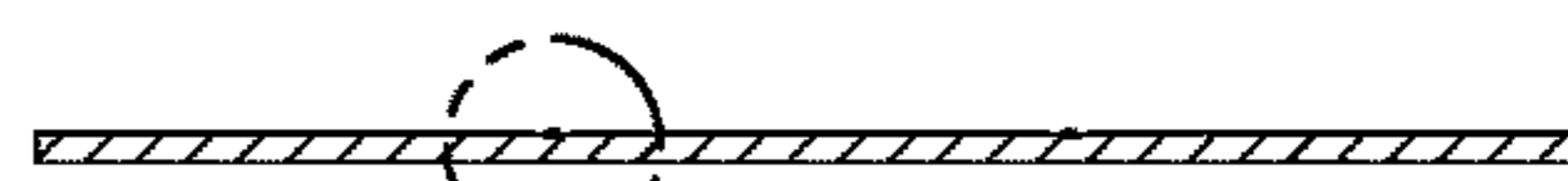

FIG. 60

FIG. 61

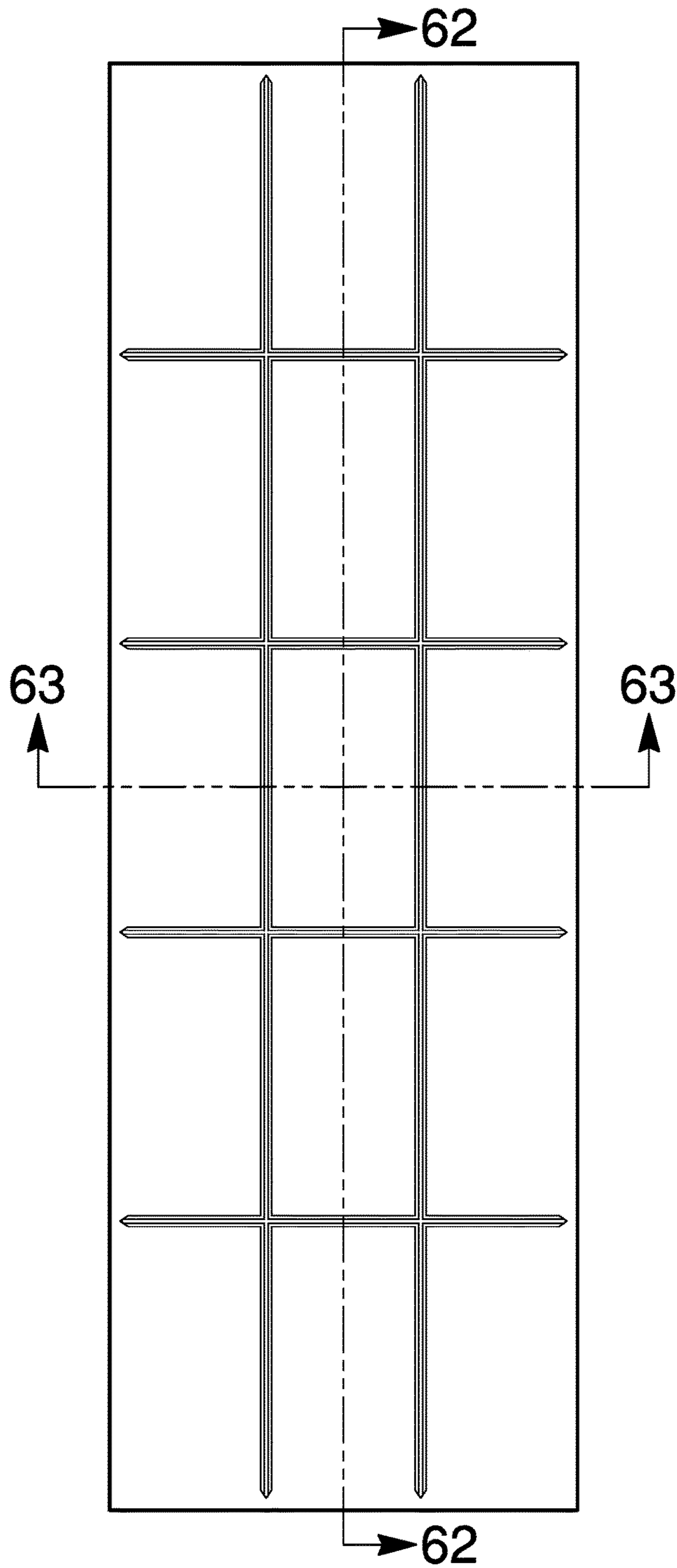

FIG. 62



FIG. 63

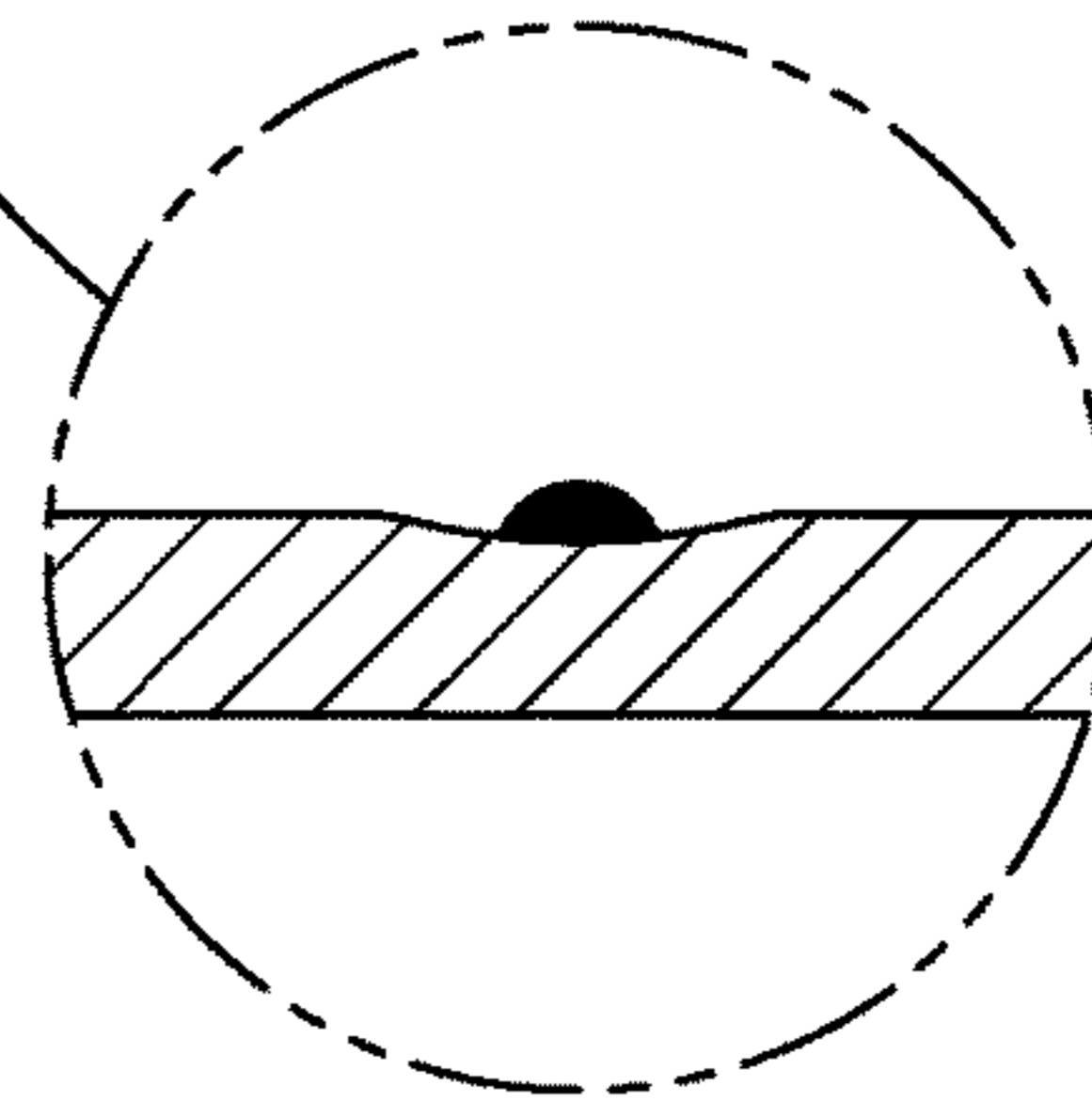
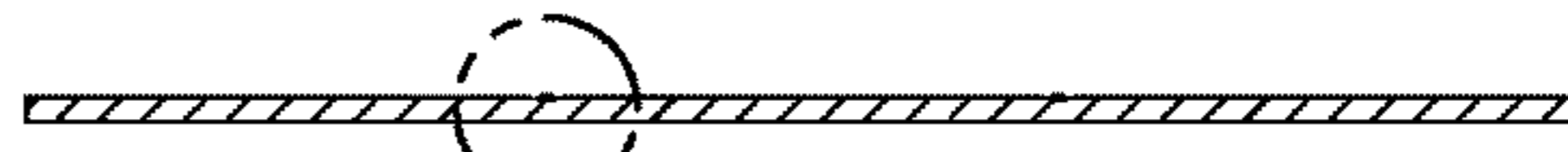

FIG. 64