



US00D779563S

(12) **United States Design Patent** (10) **Patent No.:** **US D779,563 S**  
**Foster** (45) **Date of Patent:** **\*\* Feb. 21, 2017**

(54) **BRAKE PEDALS**

(71) Applicant: **RF Products, Inc.**, Batesville, AR (US)

(72) Inventor: **Robert N. Foster**, Batesville, AR (US)

(\*\*) Term: **15 Years**

(21) Appl. No.: **29/543,159**

(22) Filed: **Oct. 21, 2015**

(51) **LOC (10) Cl.** ..... **15-03**

(52) **U.S. Cl.**  
USPC ..... **D15/17**

(58) **Field of Classification Search**

USPC ..... D15/17, 28, 22-26; 701/41, 50, 93  
CPC ..... B60K 17/10; B62D 6/001; B62D 11/24;  
B62D 11/003; B62D 11/006; B62D 7/08;  
B62D 7/09; B62D 9/00

See application file for complete search history.

(56) **References Cited**

**U.S. PATENT DOCUMENTS**

D479,167 S \* 9/2003 Faust ..... D12/174  
D565,486 S \* 4/2008 James ..... D12/114  
7,914,022 B2 \* 3/2011 Ruebusch ..... B62D 3/02  
180/401  
8,855,861 B2 \* 10/2014 Goebel ..... B62D 6/001  
701/41  
2007/0209471 A1 \* 9/2007 Nunez ..... B60T 7/06  
74/566  
2009/0241708 A1 \* 10/2009 Schaedler ..... B60K 17/10  
74/388 PS  
2009/0260912 A1 \* 10/2009 Isogai ..... B60K 17/10  
180/336  
2012/0322615 A1 \* 12/2012 Matsuzaki ..... F16H 61/0246  
477/79  
2013/0282212 A1 \* 10/2013 Michael ..... B62D 6/001  
701/22  
2013/0282214 A1 \* 10/2013 Goebel ..... B62D 6/001  
701/22

2014/0371991 A1 \* 12/2014 Buchanan ..... B62D 7/08  
701/41  
2015/0260283 A1 \* 9/2015 Iida ..... B60K 20/04  
74/473.17  
2016/0288843 A1 \* 10/2016 Fujimoto ..... B62D 25/168

\* cited by examiner

*Primary Examiner* — Mark Goodwin

(74) *Attorney, Agent, or Firm* — Joe D. Calhoun

(57) **CLAIM**

I claim the ornamental design for brake pedals, as shown and described.

**DESCRIPTION**

FIG. 1 is a perspective view of brake pedals of a representative sample of a vehicle (unclaimed), with both pedals in a resting configuration.

FIG. 2 is another perspective view of the brake pedals of FIG. 1, separate from the vehicle.

FIG. 3 is a right side elevation view thereof.

FIG. 4 is a left side elevation view thereof.

FIG. 5 is a top plan view thereof.

FIG. 6 is a bottom plan view thereof.

FIG. 7 is a front elevation thereof.

FIG. 8 is a rear elevation thereof.

FIG. 9 is a perspective view of brake pedals of a representative sample of a vehicle (unclaimed), with both pedals in a second position.

FIG. 10 is another perspective view of the brake pedals of FIG. 9, separate from the vehicle.

FIG. 11 is a right side elevation view thereof.

FIG. 12 is a left side elevation view thereof.

FIG. 13 is a top plan view thereof.

FIG. 14 is a bottom plan view thereof.

FIG. 15 is a front elevation thereof; and,

FIG. 16 is a rear elevation thereof.

The broken lines shown represent unclaimed subject matter and form no part of the claimed design.

**1 Claim, 16 Drawing Sheets**

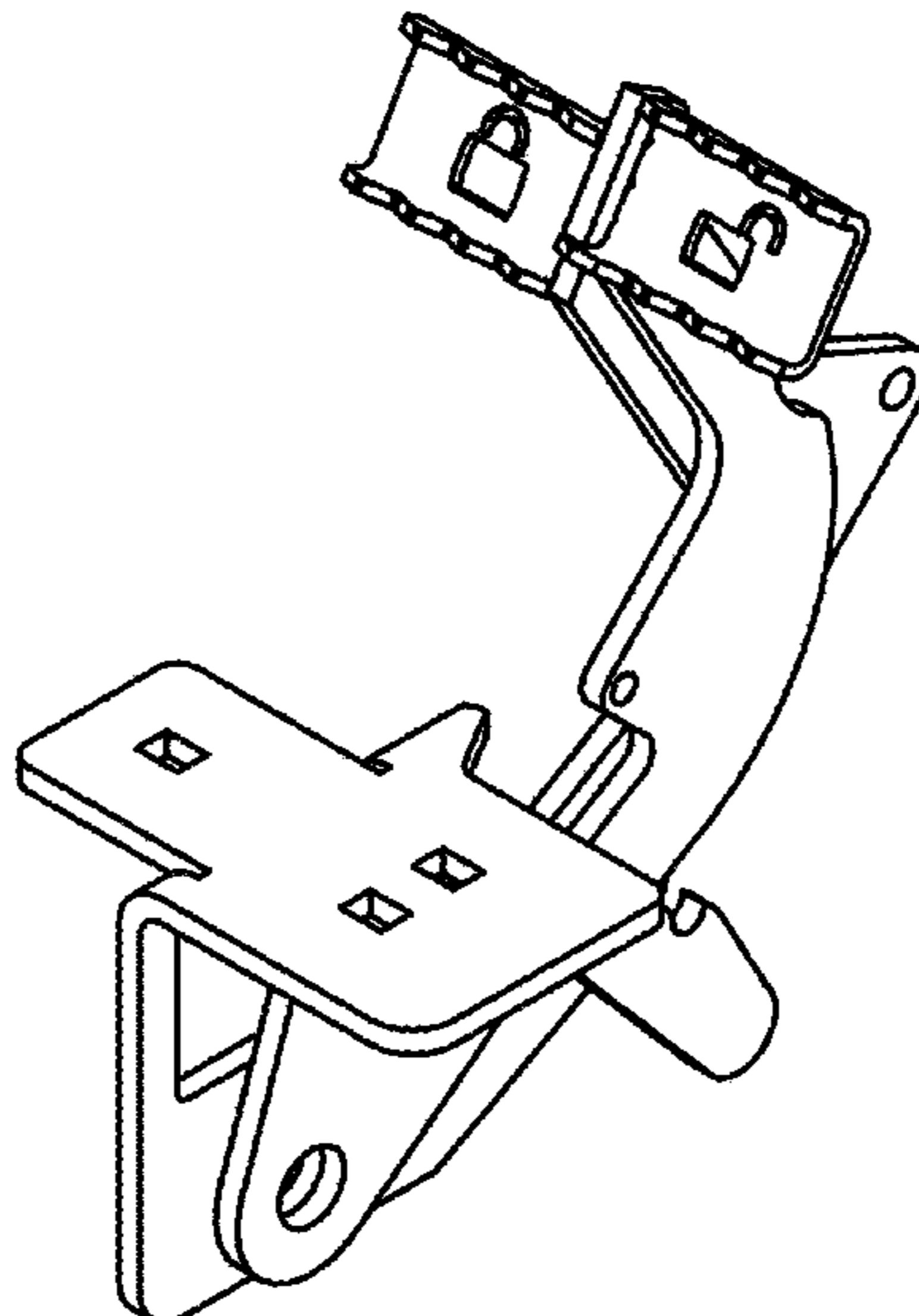

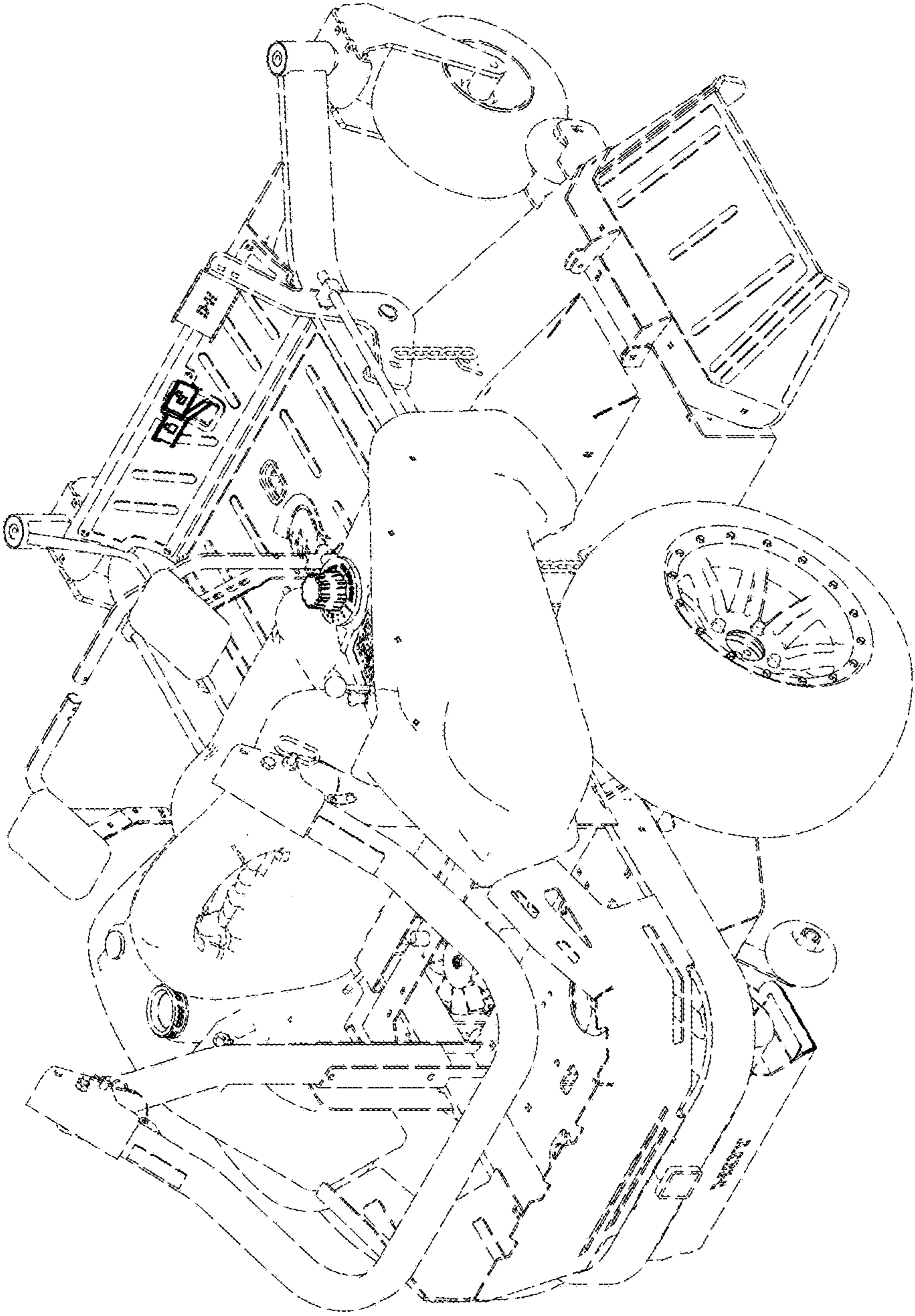

Fig.1

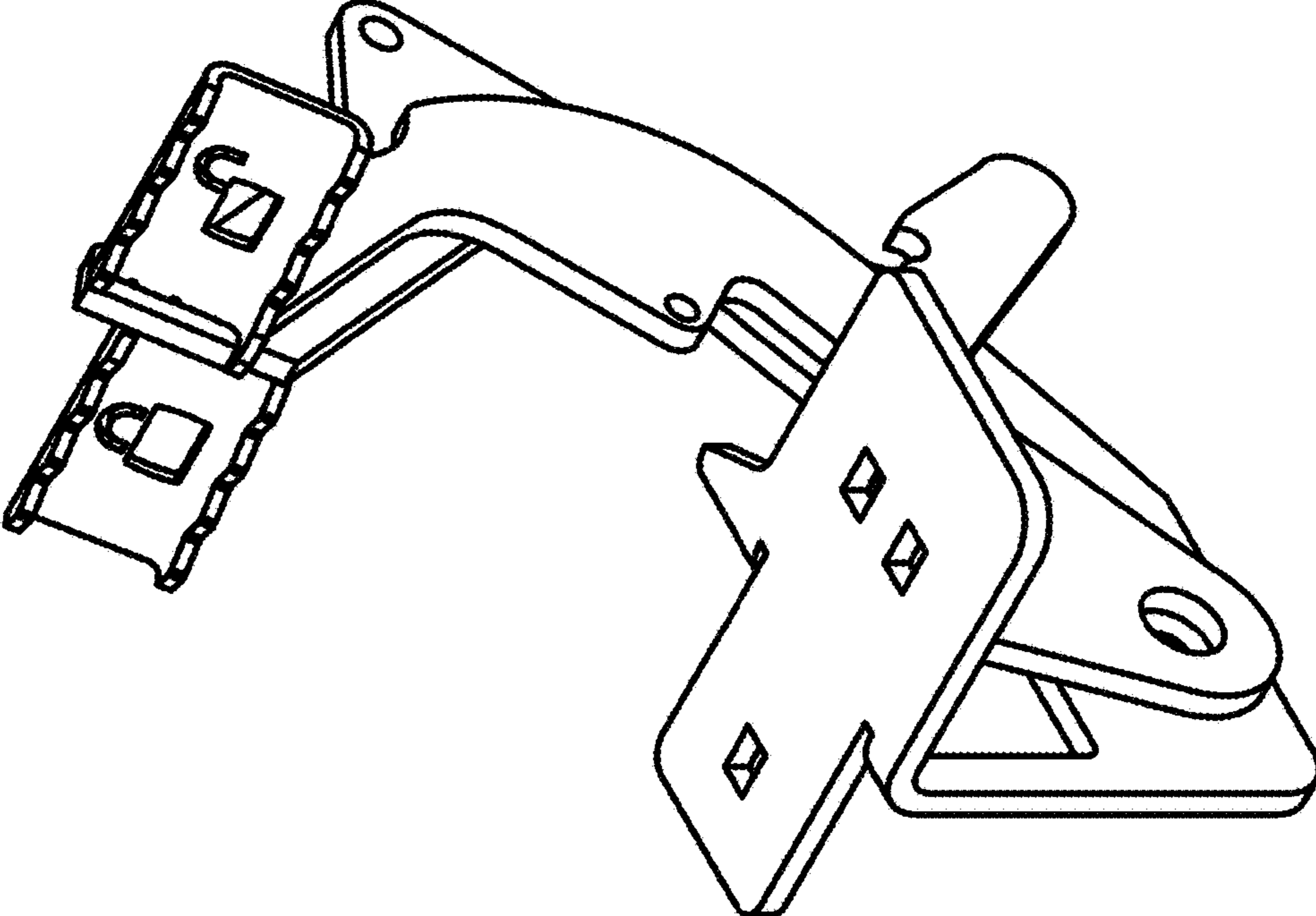

Fig. 2

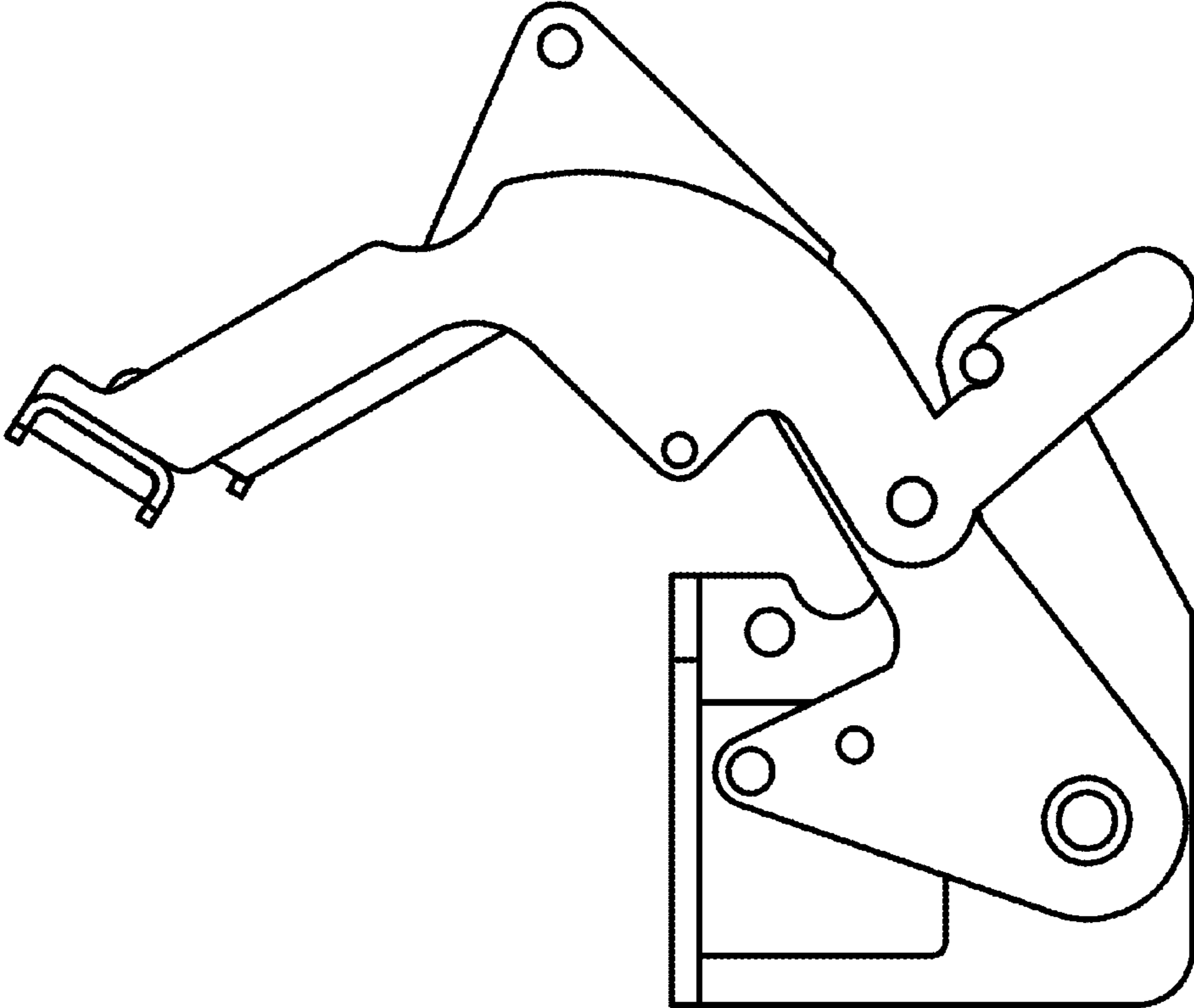

Fig. 3

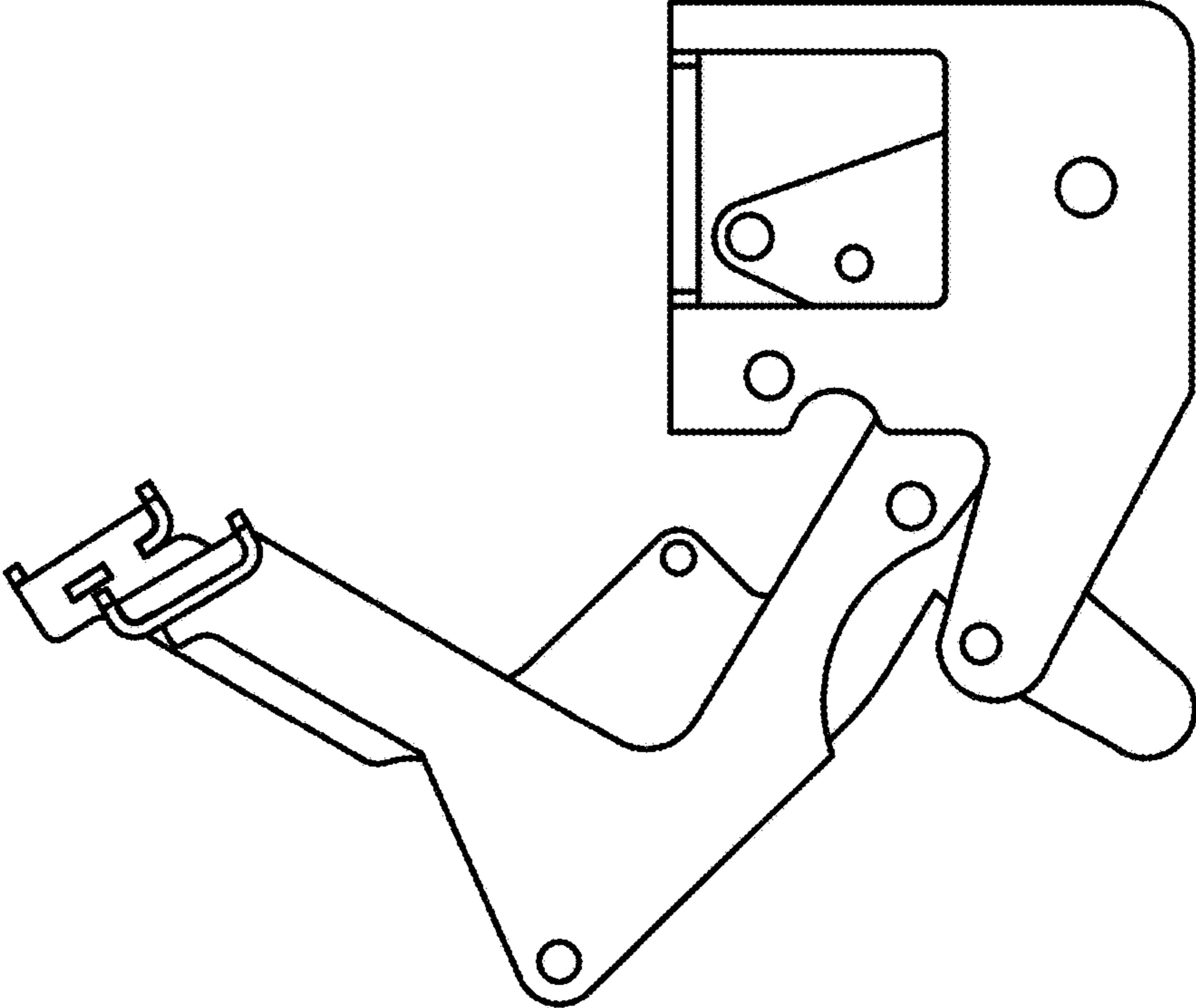

Fig.4

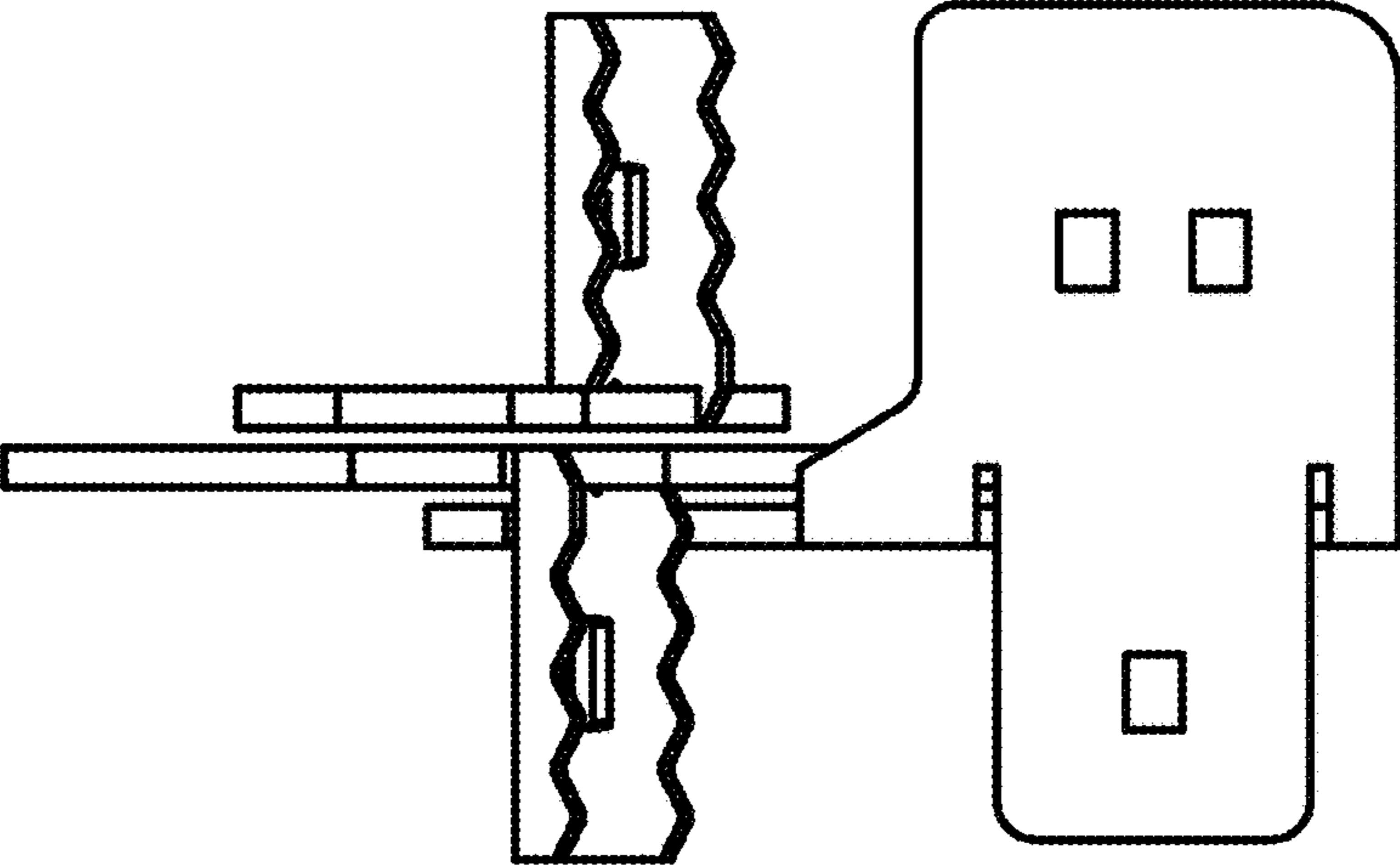
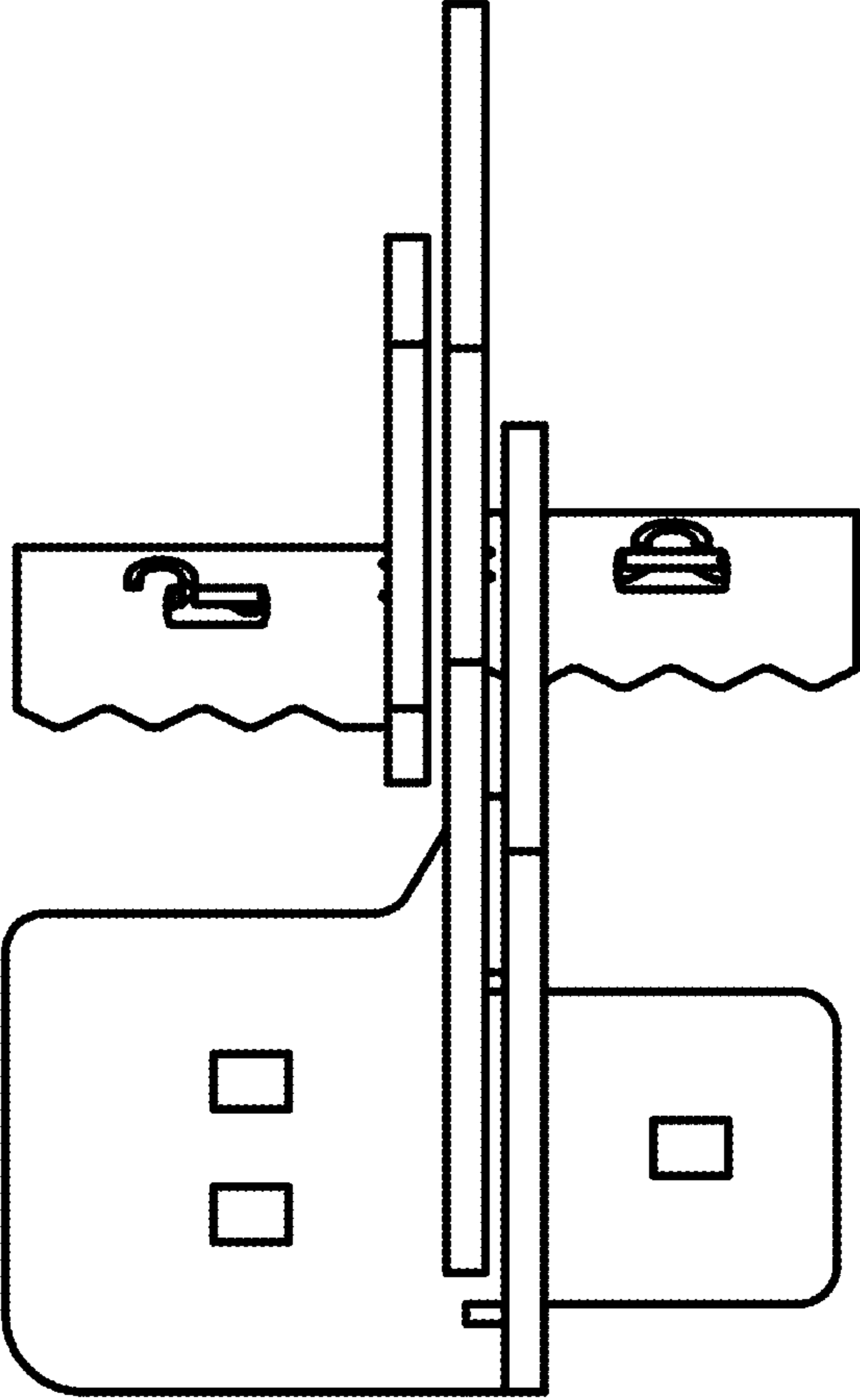

Fig. 5

Fig. 6



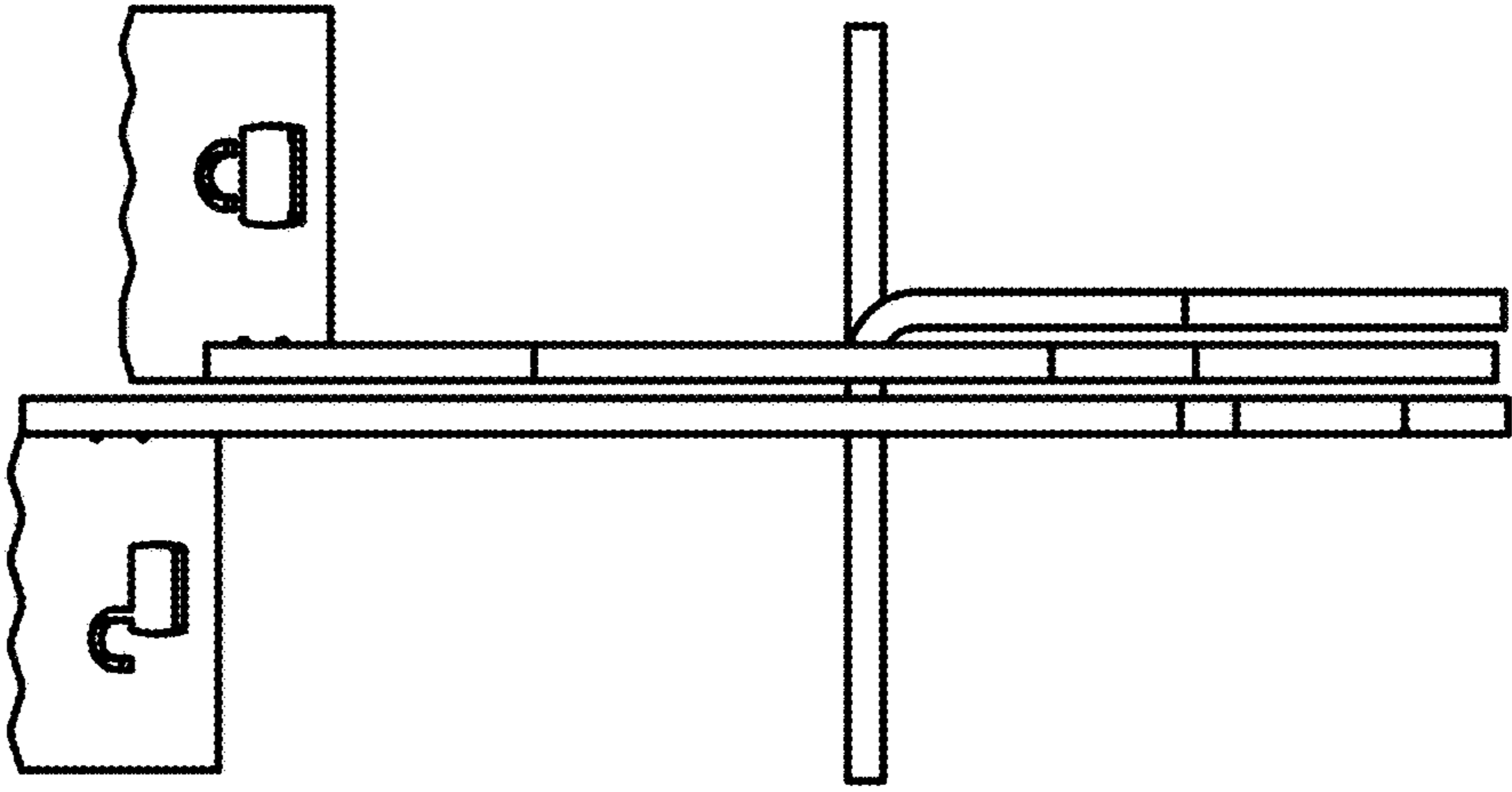

Fig. 7



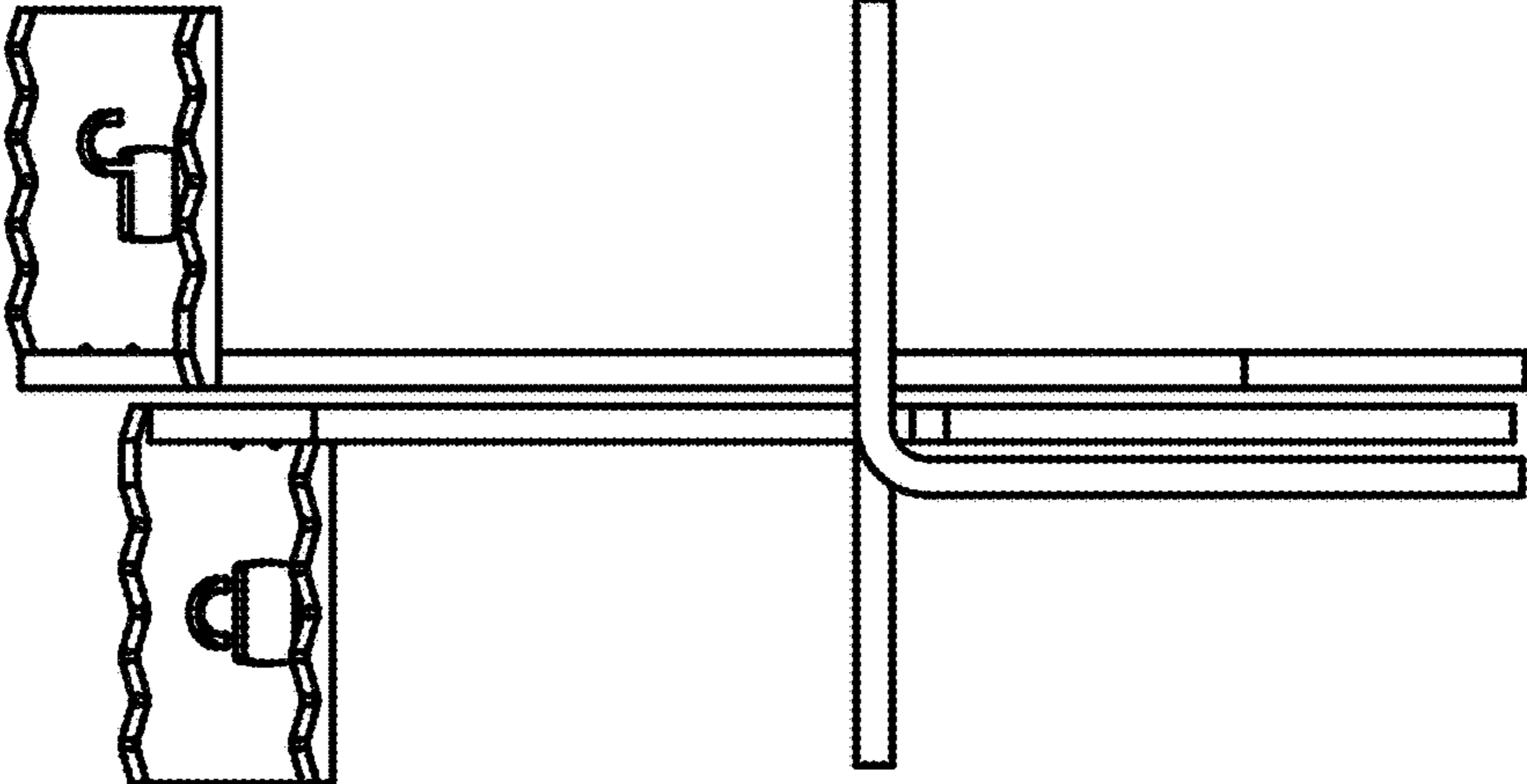

Fig. 8

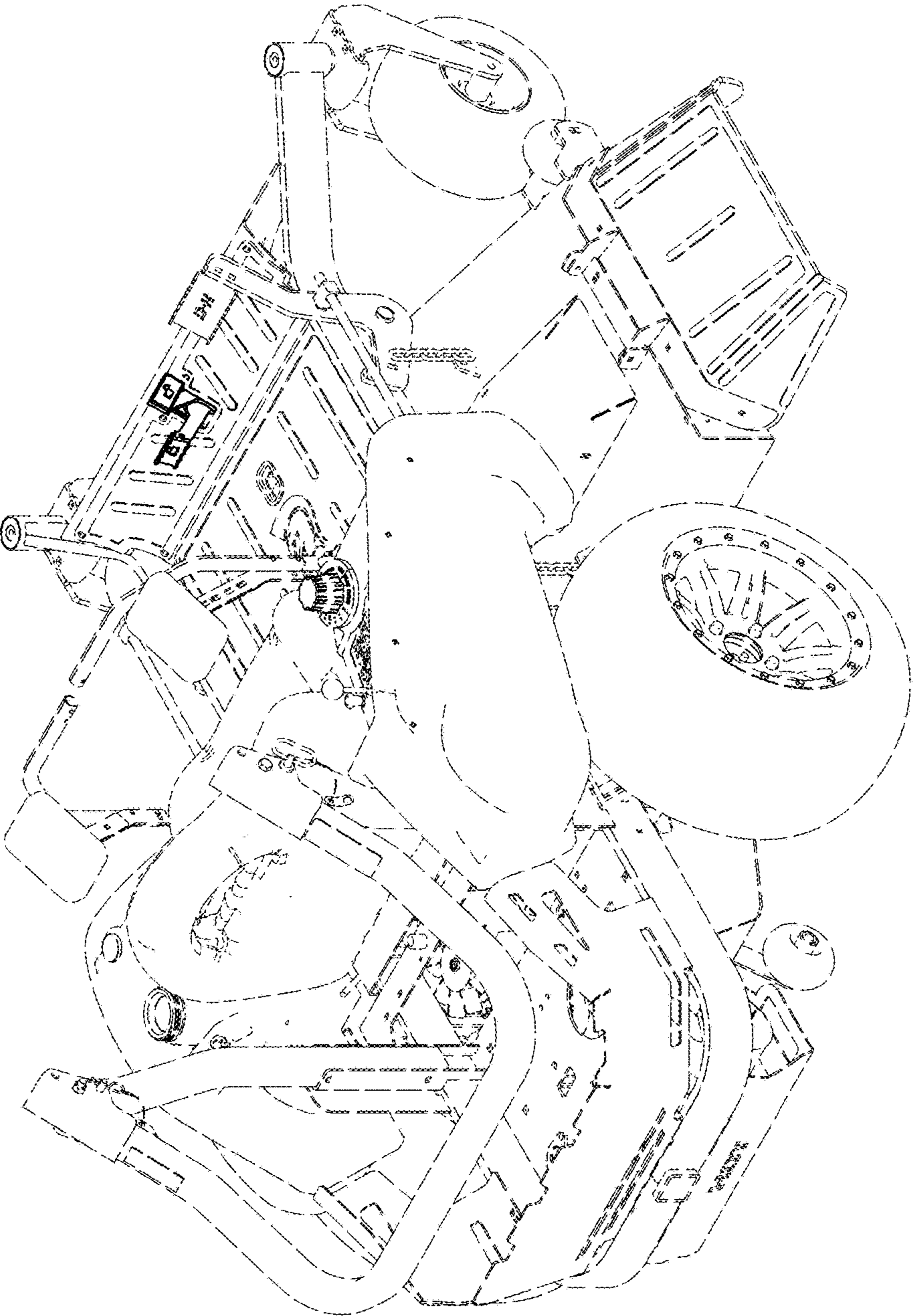

Fig. 9

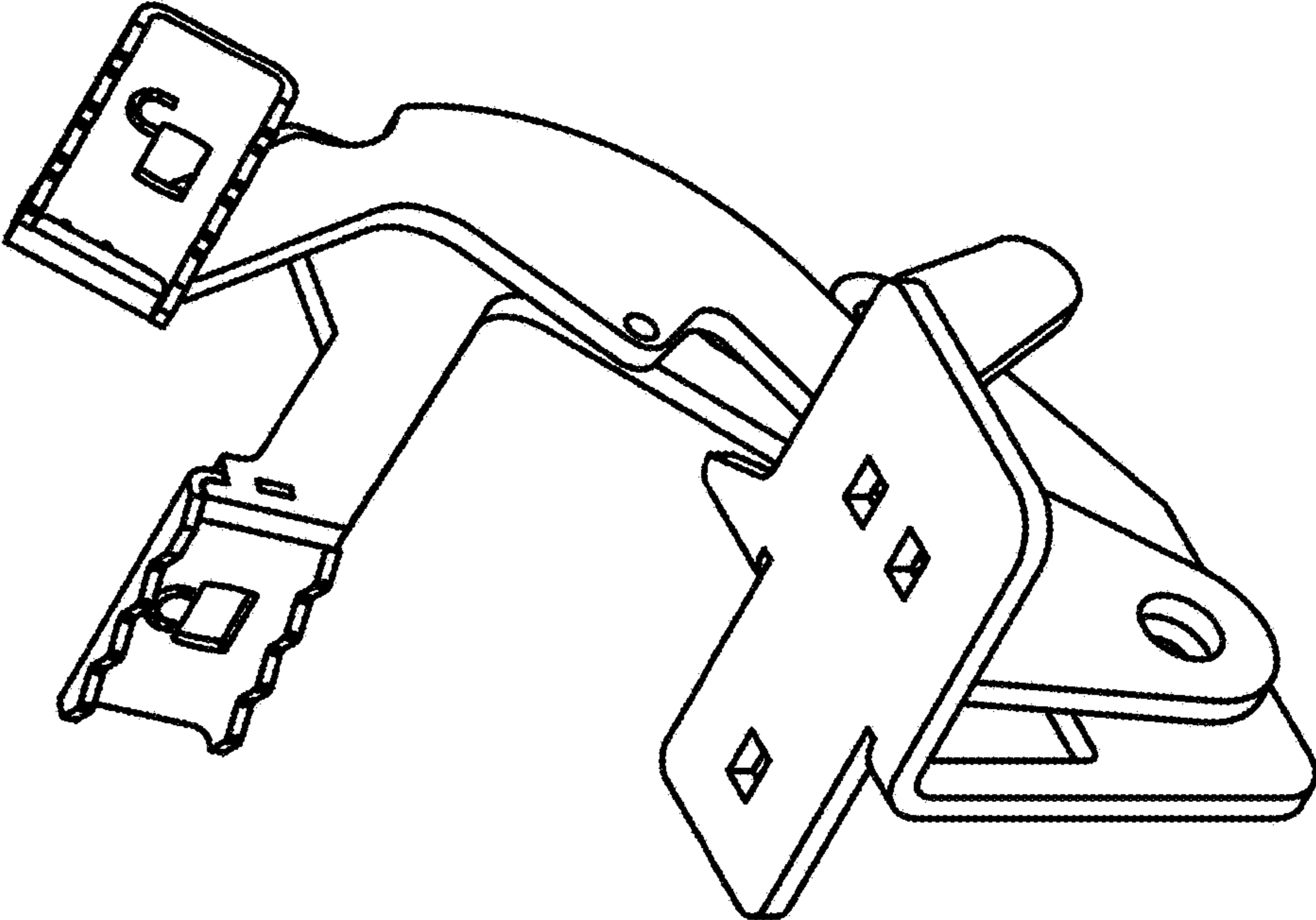

Fig. 10

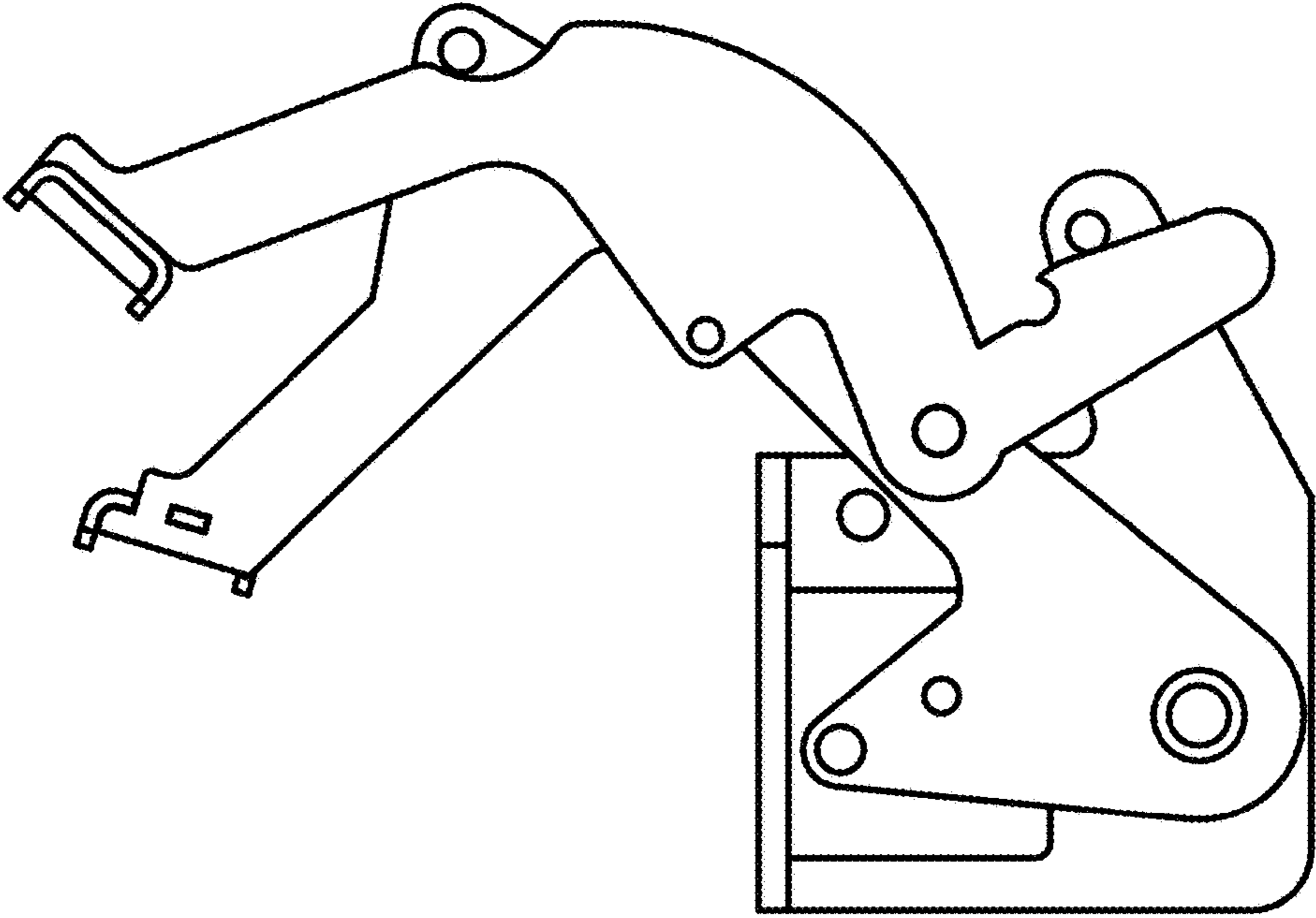

Fig.11

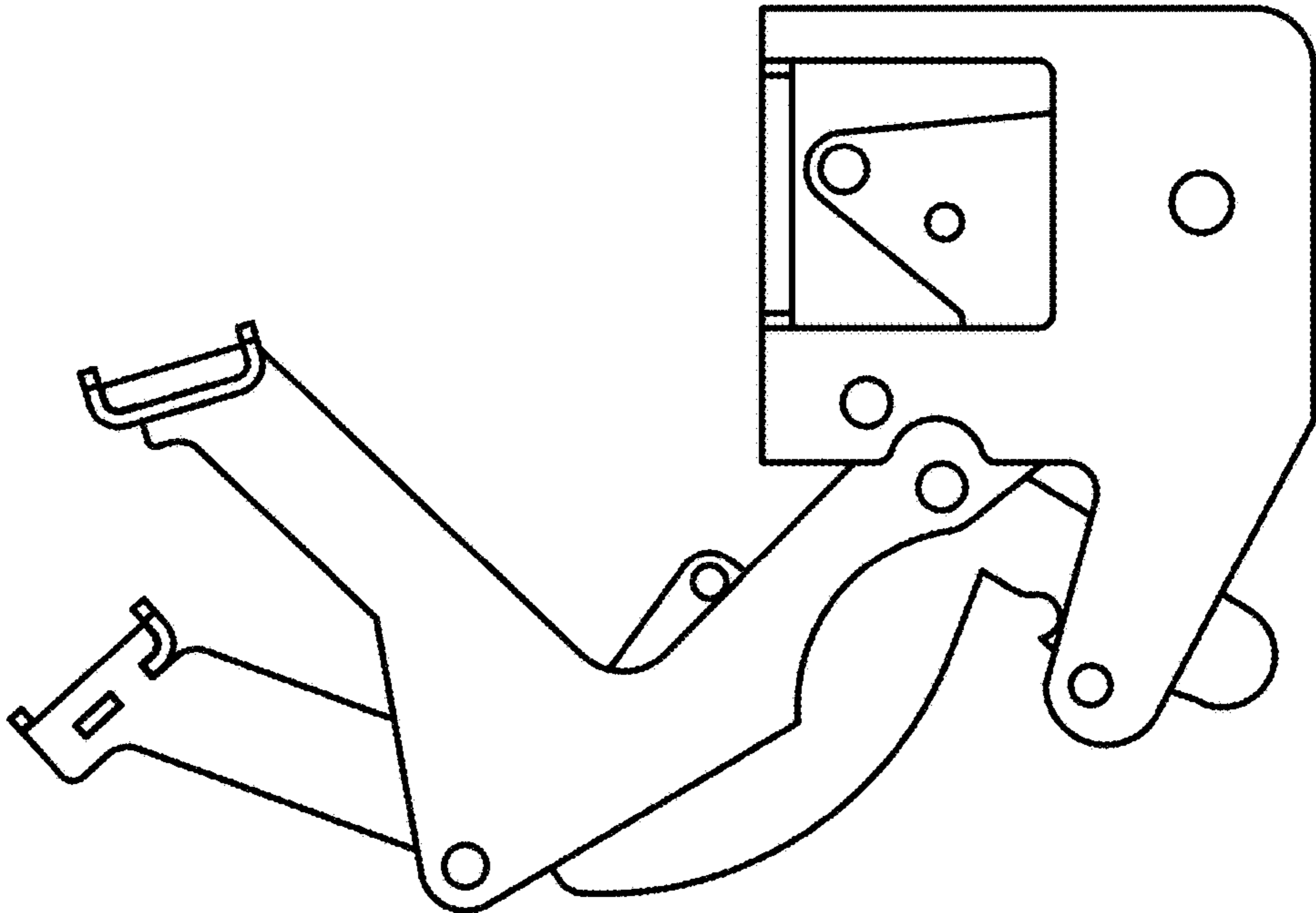

Fig.12

Fig. 13

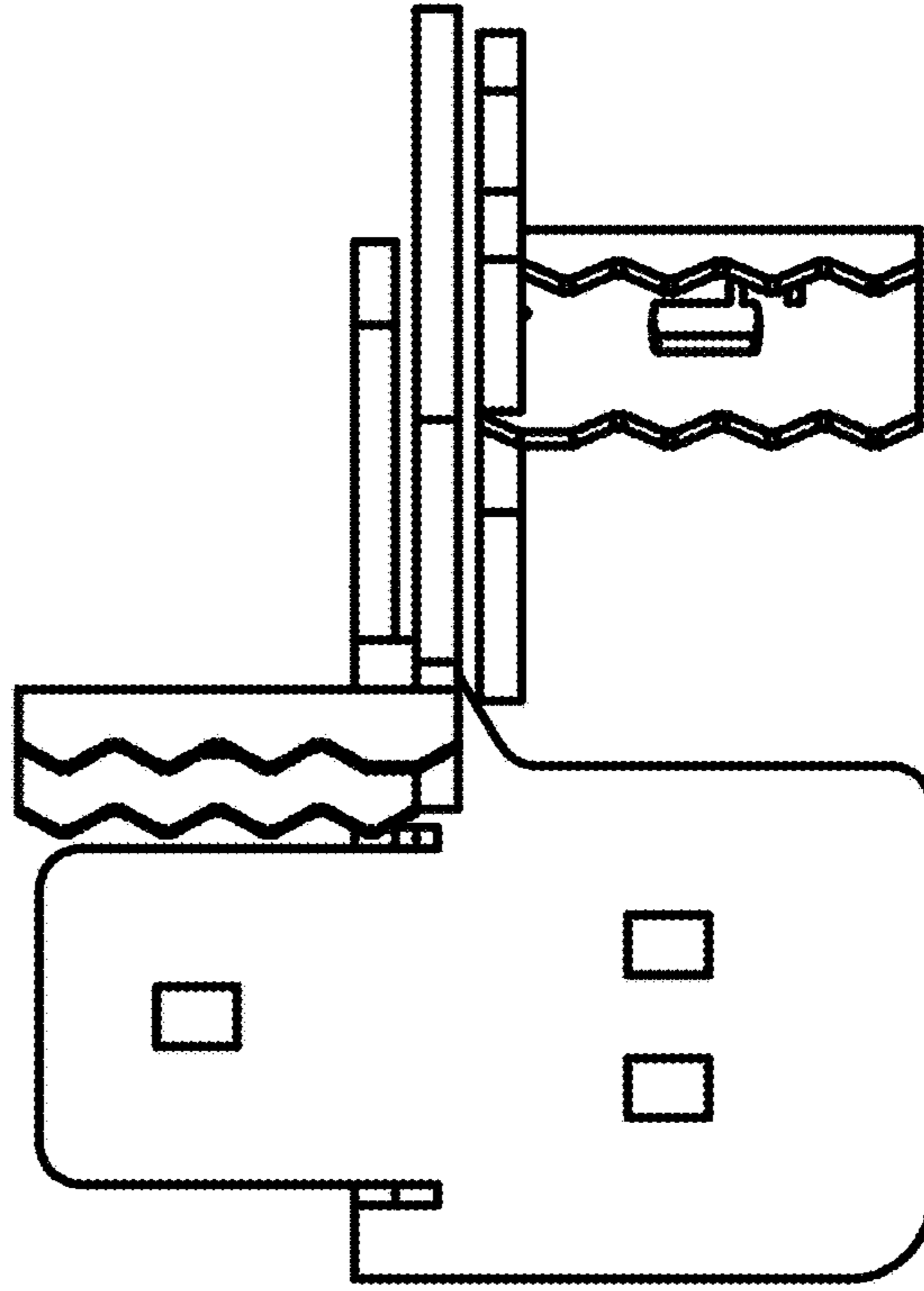
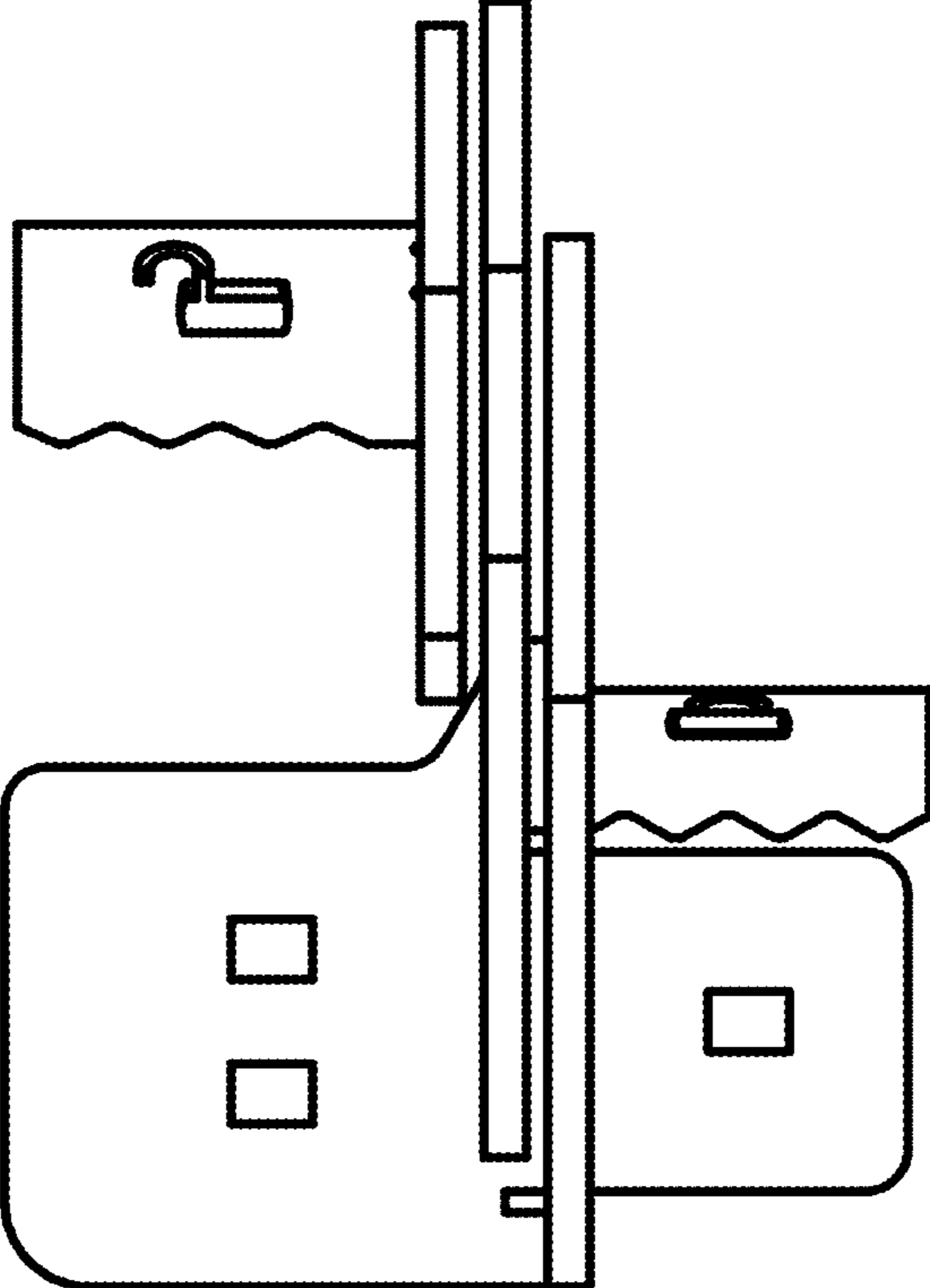

Fig.14



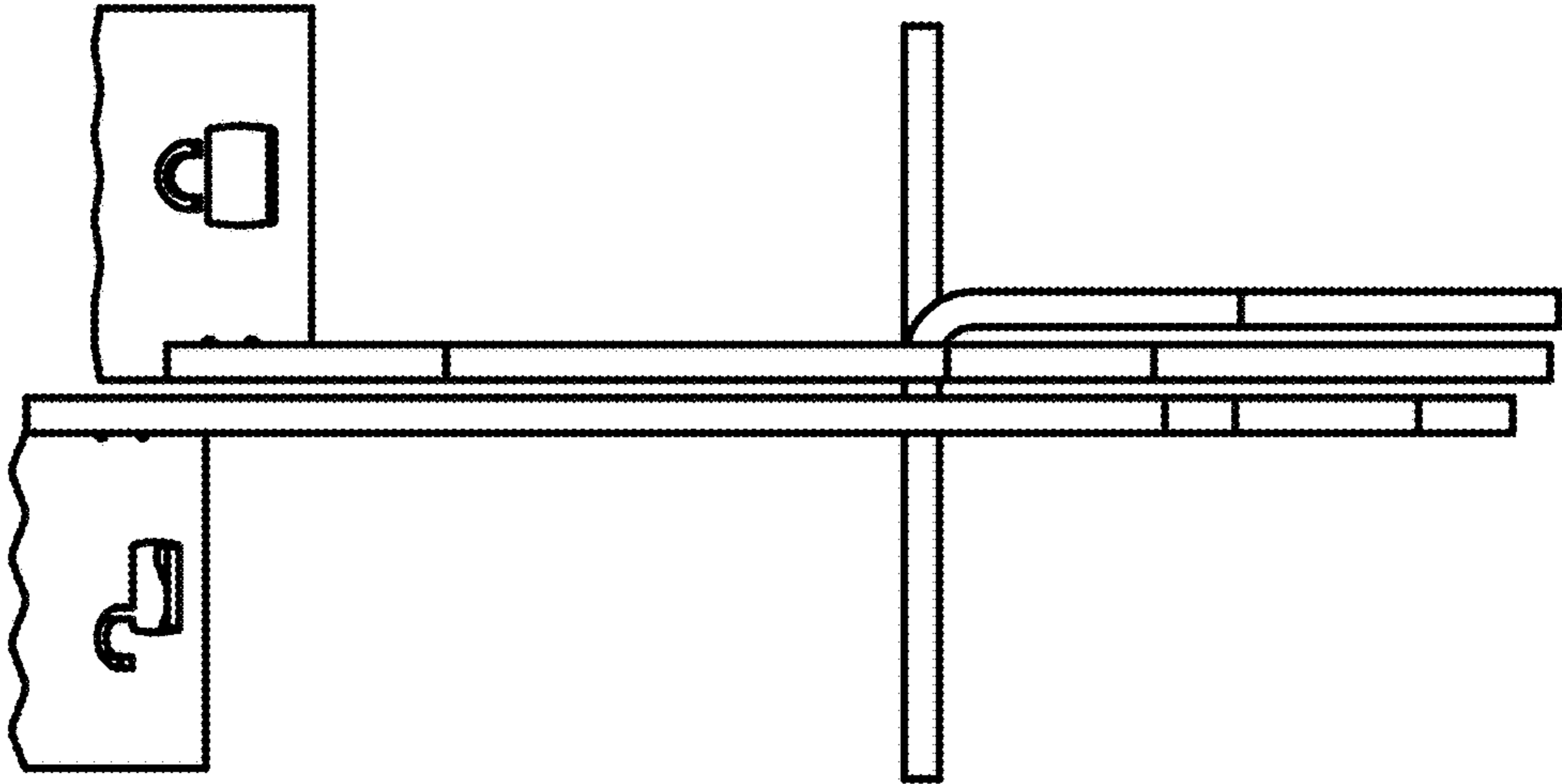

Fig. 15



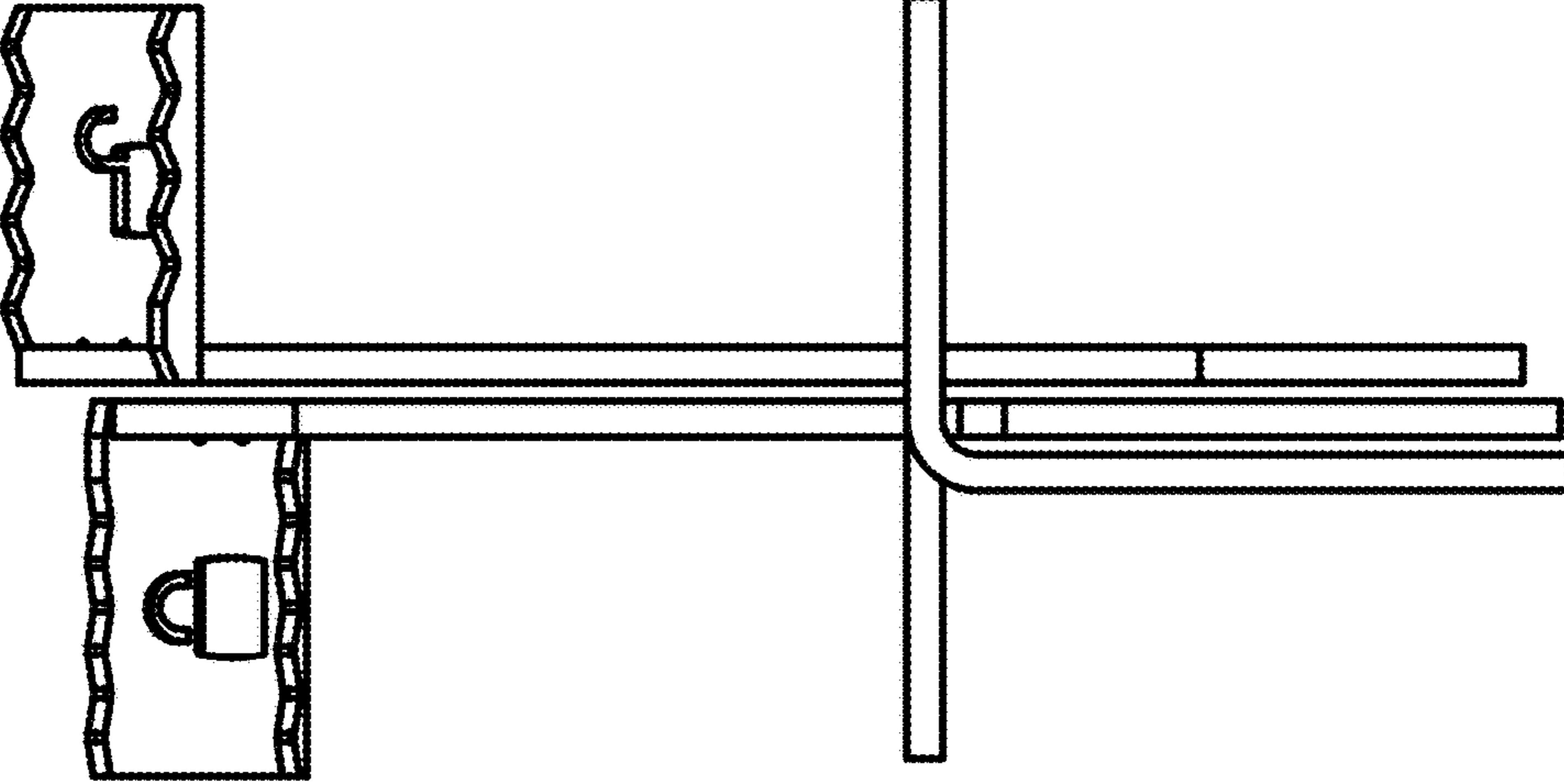

Fig.16