



US00D778974S

(12) **United States Design Patent** (10) **Patent No.:** **US D778,974 S**  
**Masek, Jr. et al.** (45) **Date of Patent:** **\*\* Feb. 14, 2017**

(54) **WATERPROOF LED ACTION CAMERA LIGHT**

(71) Applicant: **Light & Motion Industries**, Marina, CA (US)

(72) Inventors: **Theodore Dale Masek, Jr.**, Monterey, CA (US); **Benjamin McGeever**, Shoreline, WA (US); **Kevin Govan**, Lynnwood, WA (US)

(73) Assignee: **Light & Motion Industries**, Marina, CA (US)

(\*\*) Term: **14 Years**

(21) Appl. No.: **29/514,646**

(22) Filed: **Jan. 14, 2015**

(51) **LOC (10) Cl.** ..... **16-05**

(52) **U.S. Cl.**  
USPC ..... **D16/239**

(58) **Field of Classification Search**  
USPC ... D16/204, 209, 219, 237, 239, 240; 362/3, 362/10; 396/175, 177, 287  
CPC ..... G03B 15/05; G03B 2215/0514; G03B 2215/0517; G03B 2215/0542; G03B 2215/0553; G03B 2215/056; G03B 2215/0567

See application file for complete search history.

(56) **References Cited**

**U.S. PATENT DOCUMENTS**

D182,751 S *	5/1958	Wollman	.....	D16/204
D185,117 S *	5/1959	Birns	.....	D16/204
D214,214 S *	5/1969	Monson	.....	D16/240
D214,764 S *	7/1969	Stahel	.....	D16/239
D229,099 S *	11/1973	Quinn	.....	D16/239
D232,264 S *	7/1974	Kitagawa	.....	D16/239
D232,773 S *	9/1974	Kato	.....	D16/239

D232,973 S *	9/1974	Arnoldy	.....	D16/239
D233,912 S *	12/1974	Nagele	.....	D16/239
D234,094 S *	1/1975	Lange	.....	D16/209
D239,139 S *	3/1976	Karaki	.....	D16/240
D241,575 S *	9/1976	Schade	.....	D16/239
D250,475 S *	12/1978	Kando	.....	D16/240

(Continued)

**FOREIGN PATENT DOCUMENTS**

DE 402009006346-0001 \* 3/2012

**OTHER PUBLICATIONS**

<http://www.trendhunter.com/trends/gopro-sidekick> Posted Jan. 18, 2015.\*

(Continued)

*Primary Examiner* — Susan Bennett Hattan

*Assistant Examiner* — Leanne Was

(74) *Attorney, Agent, or Firm* — Thomas M. Freiburger

(57) **CLAIM**

The ornamental design for a waterproof LED action camera light, substantially as shown and described.

**DESCRIPTION**

FIG. 1 is a front left perspective view of a waterproof LED action camera light according to our new design; FIG. 2 is a top plan view thereof; FIG. 3 is a right side view thereof; FIG. 4 is a front view thereof; FIG. 5 is a left side view thereof; FIG. 6 is a rear view thereof; and, FIG. 7 is a bottom plan view thereof.

That which is depicted in solid lines in the drawings represents the claimed design. The elements depicted in broken lines in FIGS. 3 and 6 depict portions of the waterproof LED action camera light that form no part of the claimed design.

**1 Claim, 4 Drawing Sheets**

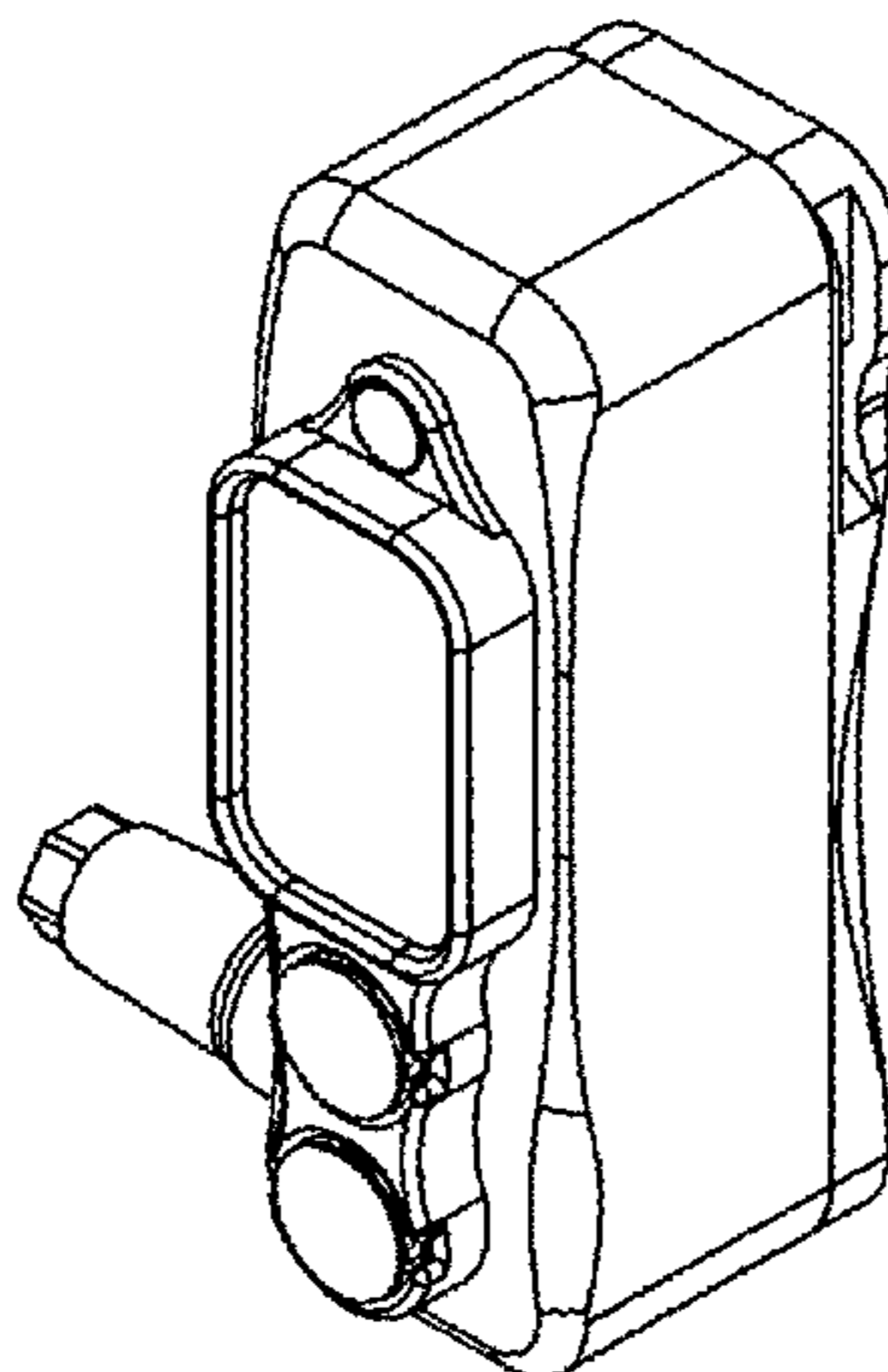

(56)

**References Cited**

U.S. PATENT DOCUMENTS

D250,766	S *	1/1979	Ozawa .....	D16/239
D265,831	S *	8/1982	Schultes .....	D16/239
D267,252	S *	12/1982	Quinn .....	D16/240
D287,122	S *	12/1986	Hollister .....	D13/134
D302,422	S *	7/1989	Justiano .....	D13/133
D615,935	S *	5/2010	An .....	D13/180
D616,386	S *	5/2010	Sheng .....	D13/180
D621,802	S *	8/2010	Hussell .....	D13/180
2005/0175333	A1 *	8/2005	Yamada .....	G03B 15/03 396/177
2009/0196595	A1 *	8/2009	Okubo .....	G03B 15/05 396/175
2014/0139099	A1 *	5/2014	Sakamoto .....	G03B 15/05 313/234

OTHER PUBLICATIONS

<http://news.doddlme.com/equipment/doddlereviews-light-motion-sidekick-duo-video-light-for-gopro/> Posted Jun. 15, 2015.\*

<http://www.kayakerofishingtackle.com/featured-slider/light-motion-sidekick-light.html> Available Jun. 10, 2015.\*

\* cited by examiner

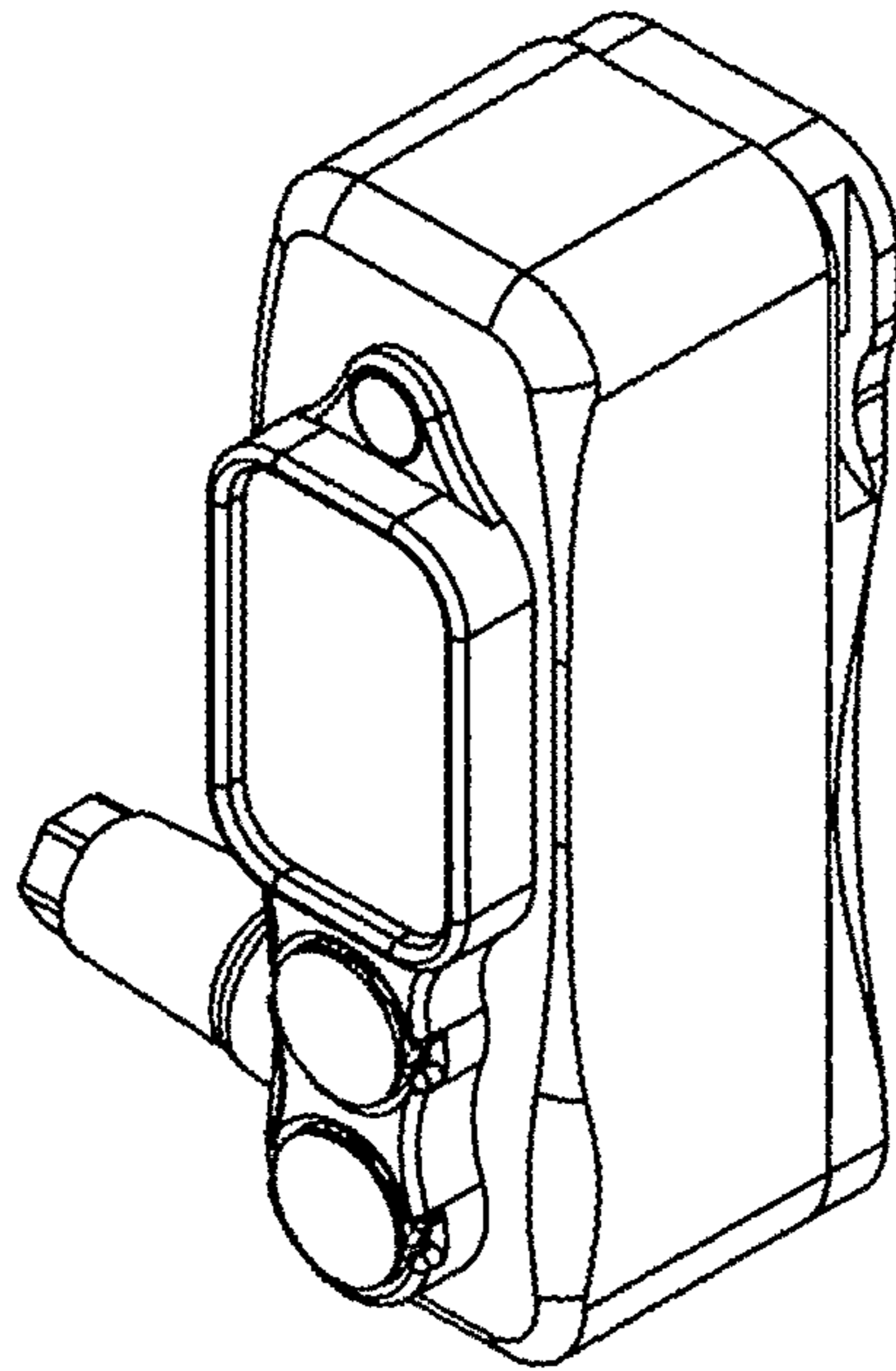

FIG. 1

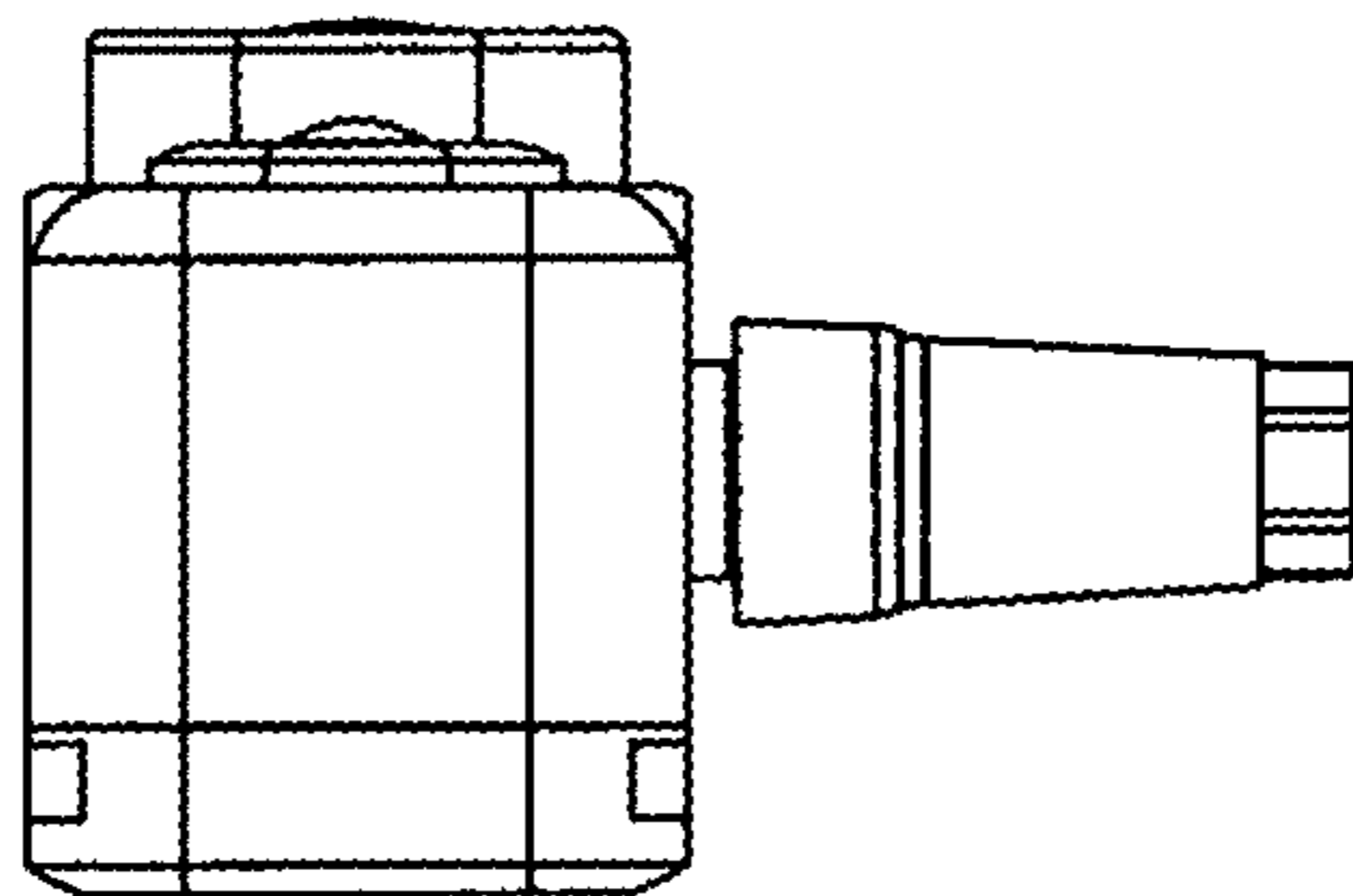

FIG. 2

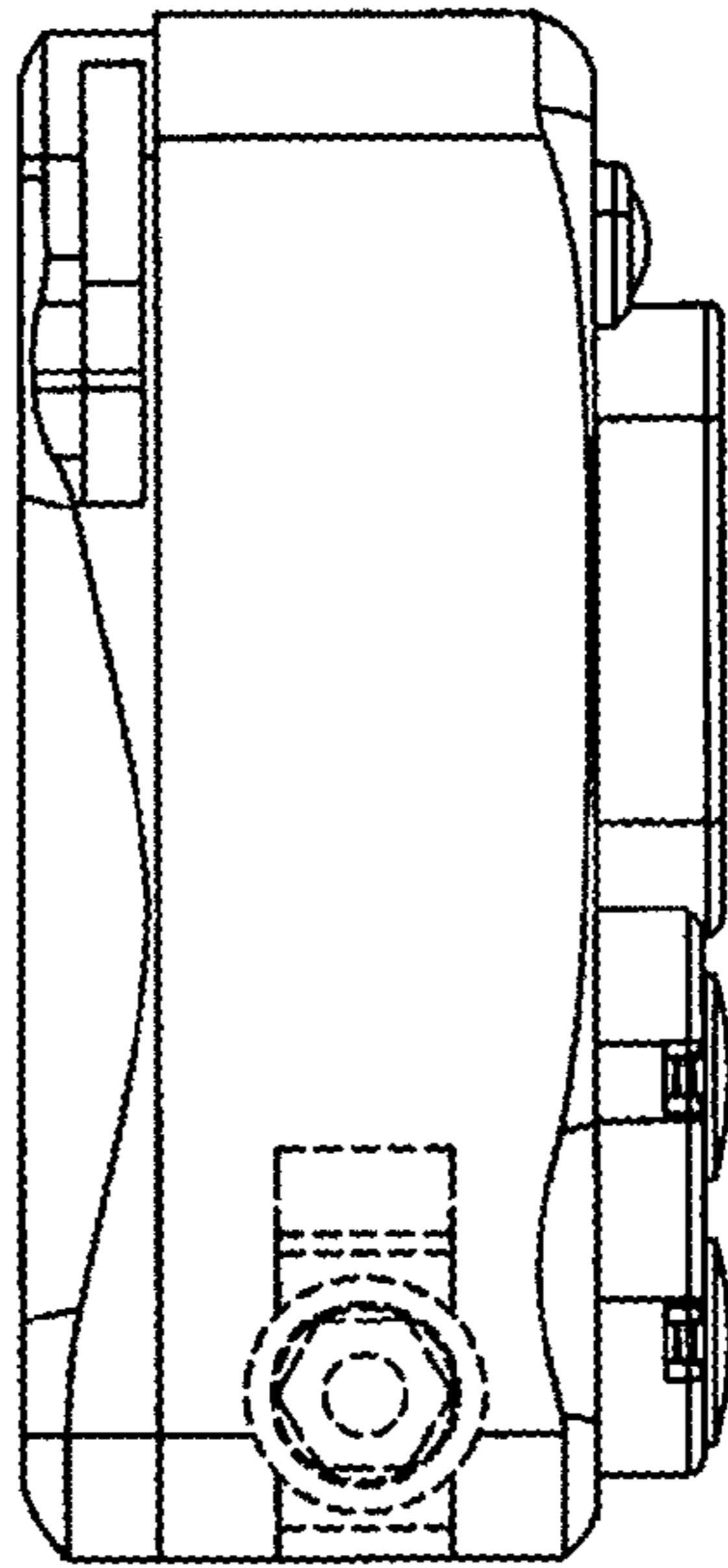

FIG. 3

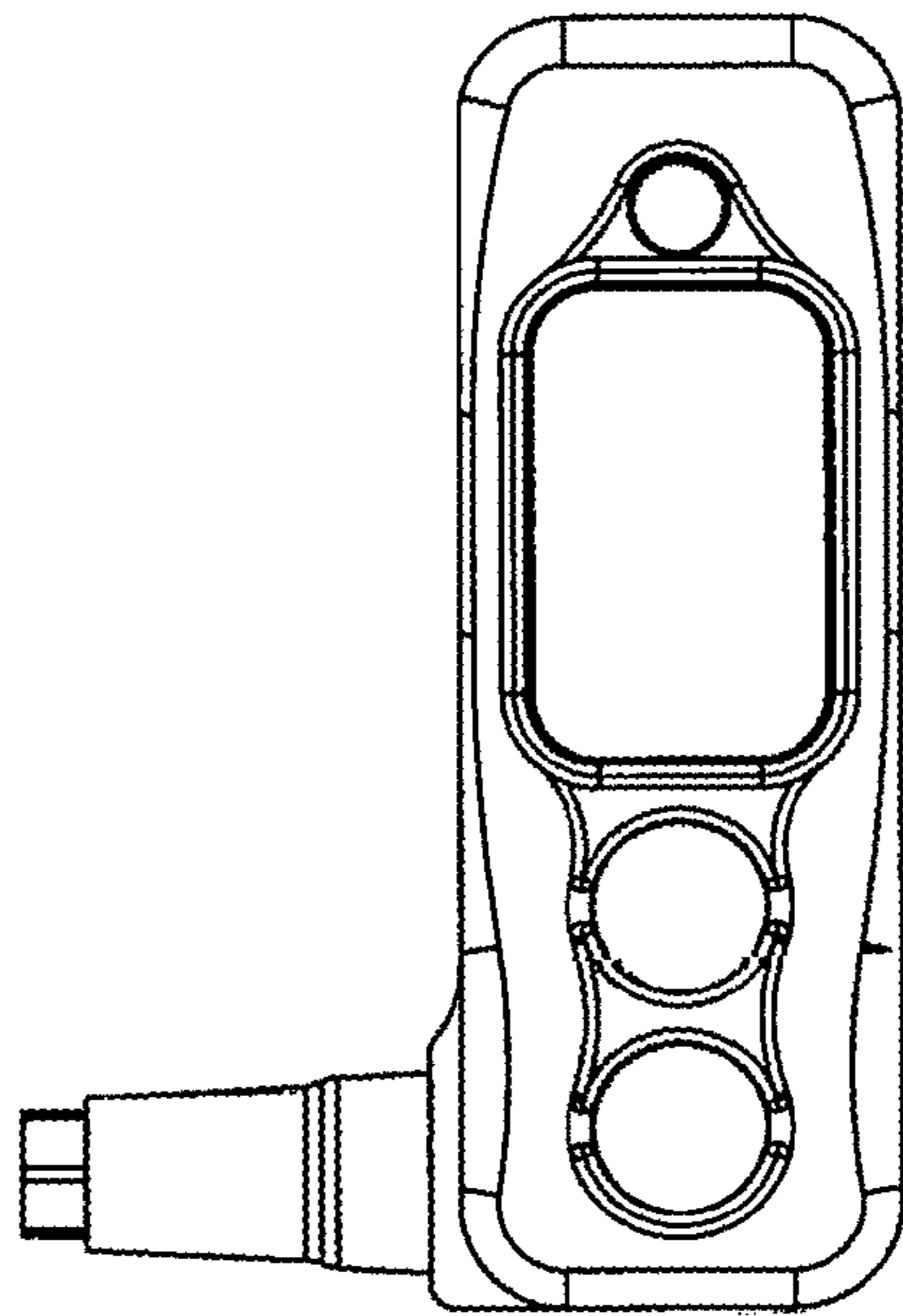

FIG. 4

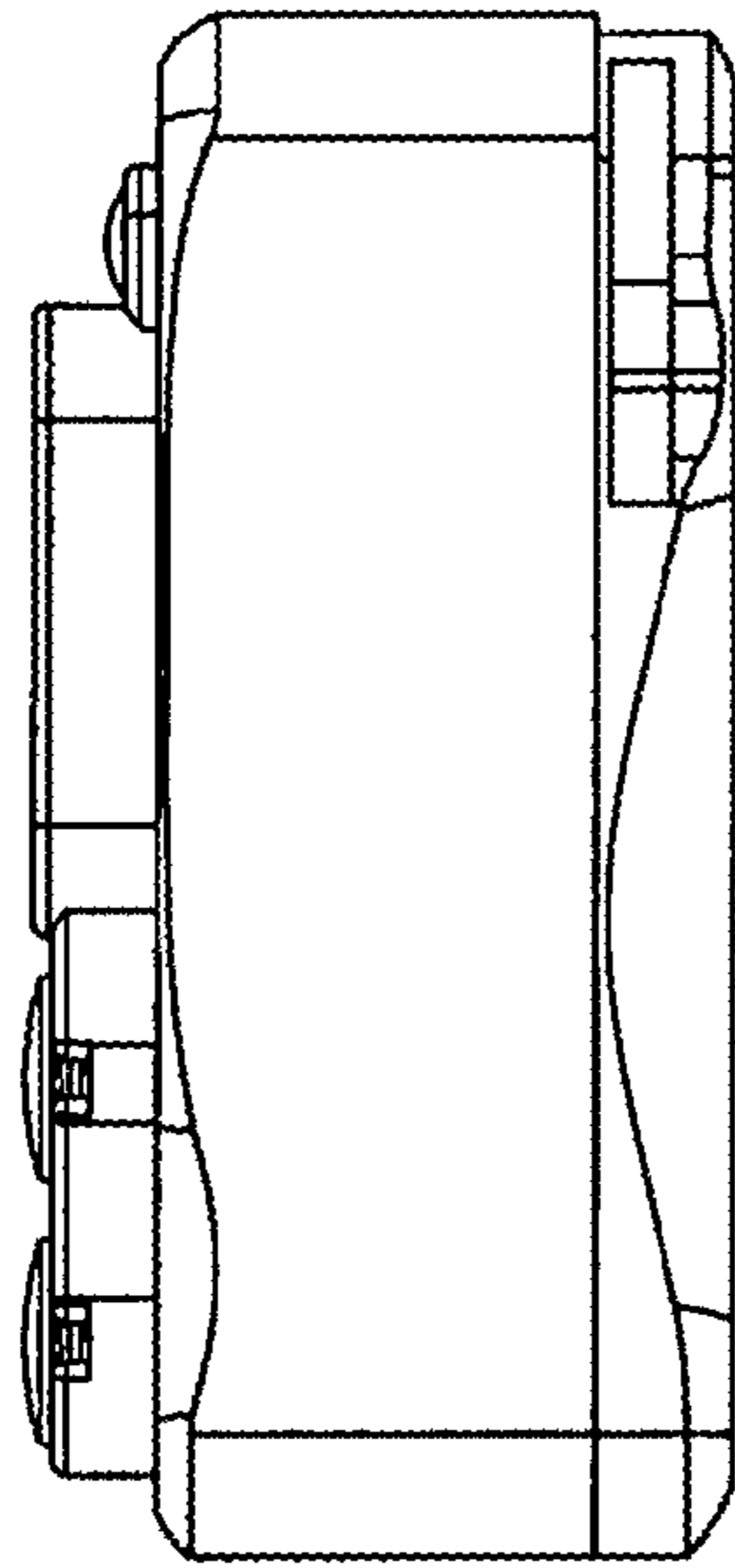

FIG. 5

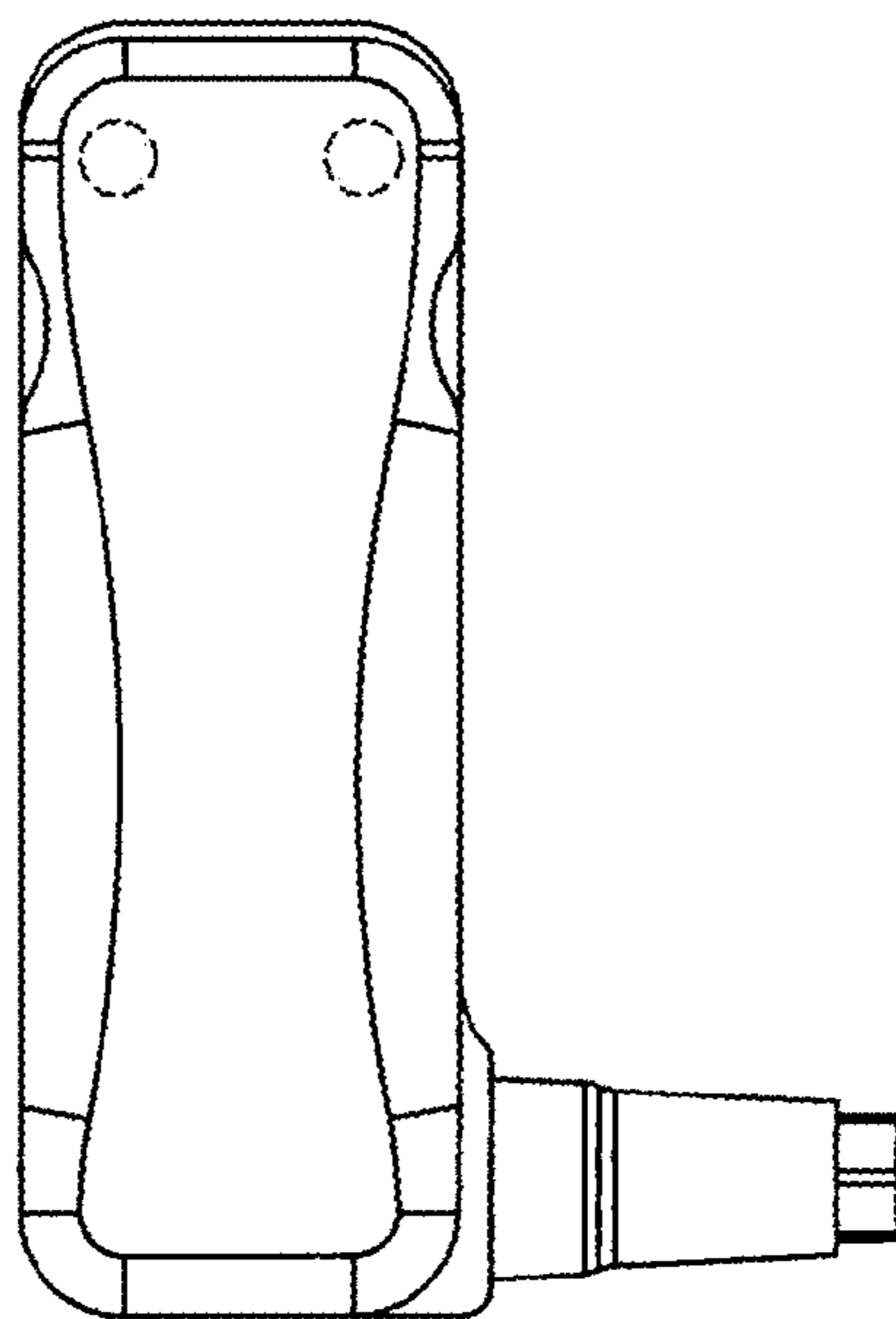

FIG. 6

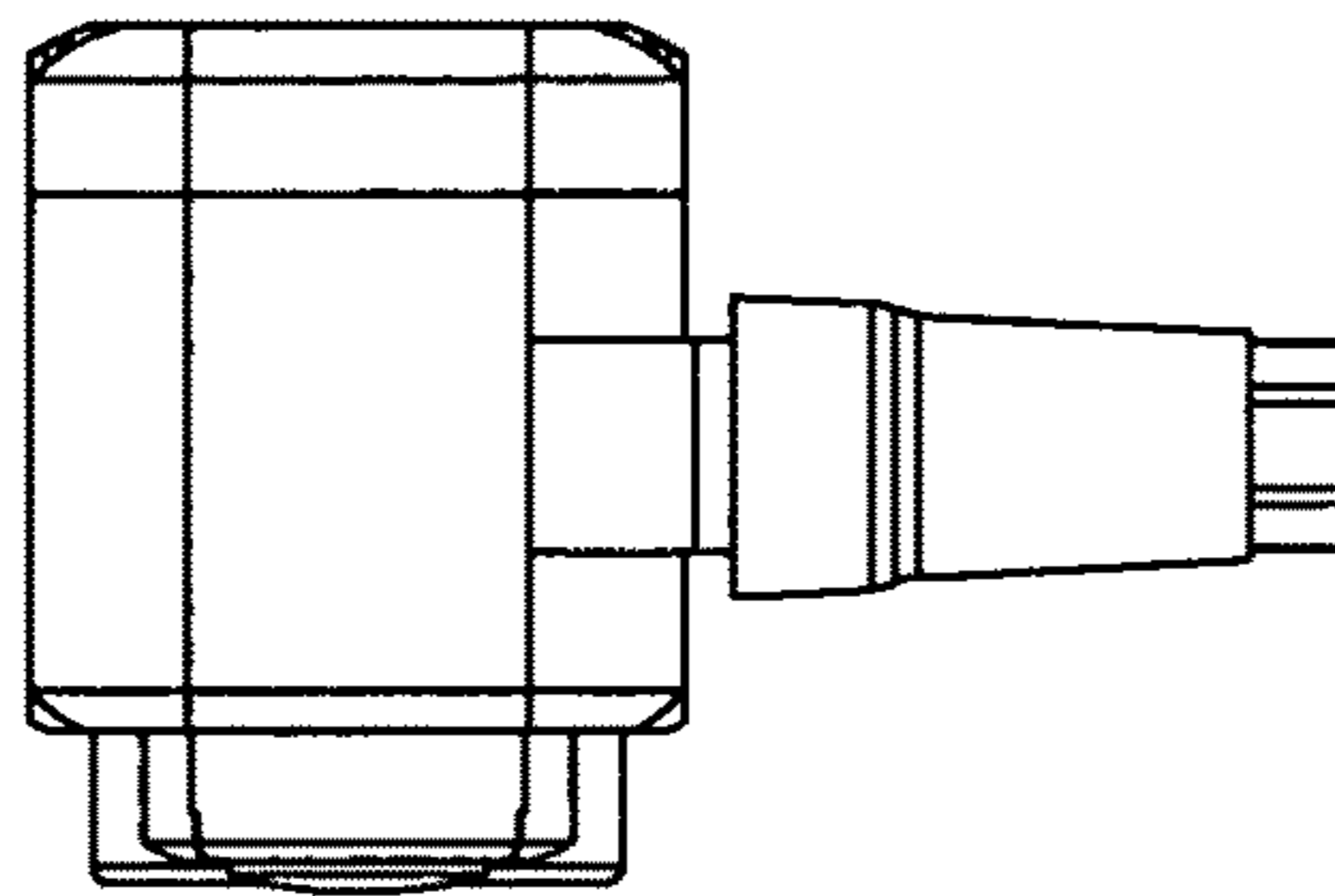

FIG. 7