



US00D778908S

(12) **United States Design Patent**
Mase

(10) **Patent No.:** **US D778,908 S**

(45) **Date of Patent:** **** Feb. 14, 2017**

(54) **IMAGE DISPLAY DEVICE**

(71) Applicant: **BROTHER INDUSTRIES, LTD.**,
Nagoya-shi, Aichi-ken (JP)

(72) Inventor: **Yosuke Mase**, Nagoya (JP)

(73) Assignee: **BROTHER INDUSTRIES, LTD.**,
Nagoya-shi (JP)

(**) Term: **15 Years**

(21) Appl. No.: **29/567,967**

(22) Filed: **Jun. 14, 2016**

(30) **Foreign Application Priority Data**

Dec. 22, 2015 (JP) 2015-28475

(51) **LOC (10) Cl.** **14-02**

(52) **U.S. Cl.**
USPC **D14/372**

(58) **Field of Classification Search**

USPC D14/372, 496, 432, 371, 125, 126, 129,
D14/299; D16/300-342; 351/158, 153,
D16/144; 345/7-9, 905; 455/344;
348/115, 53, 121, 739

CPC G02B 27/017; G02B 27/0158; G02B
27/0161; G02B 27/0181; G02B 27/0185;
G02B 27/0189

See application file for complete search history.

(56) **References Cited**

U.S. PATENT DOCUMENTS

D692,424 S * 10/2013 Pombo D14/372
D702,234 S * 4/2014 Pombo D14/372
D713,406 S * 9/2014 Pombo D14/372
D714,786 S * 10/2014 Pombo D14/372

D727,896 S * 4/2015 Lалуque D14/372
D730,352 S * 5/2015 Chow D14/372
D737,821 S * 9/2015 Cho D14/205
D740,284 S * 10/2015 Maeda D14/372
D751,073 S * 3/2016 Nagao D14/372
D760,225 S * 6/2016 Passmore D14/372
D762,212 S * 7/2016 Iritani D14/372
D764,467 S * 8/2016 Nokuo D14/372
2013/0285886 A1* 10/2013 Pombo G02B 27/0149
345/8

* cited by examiner

Primary Examiner — Austin Murphy

(74) *Attorney, Agent, or Firm* — Oliff PLC

(57) **CLAIM**

The ornamental design for an image display device, as shown and described.

DESCRIPTION

FIG. 1 is a top, rear, right-side perspective view of an image display device;

FIG. 2 is a front view thereof;

FIG. 3 is a top view thereof;

FIG. 4 is a right-side view thereof;

FIG. 5 is a left-side view thereof;

FIG. 6 is a bottom view thereof; and,

FIG. 7 is a bottom, front, left-side perspective view thereof.

The broken lines depict environmental subject matter only and form no part of the claimed design. The dot-dash lines represent a boundary between claimed and unclaimed subject matter. The rear view contains environmental subject matter only, and thus is not depicted. The zig-zag broken lines indicate a portion of the environmental subject matter that has been truncated to allow a clear view of the claimed subject matter.

1 Claim, 6 Drawing Sheets

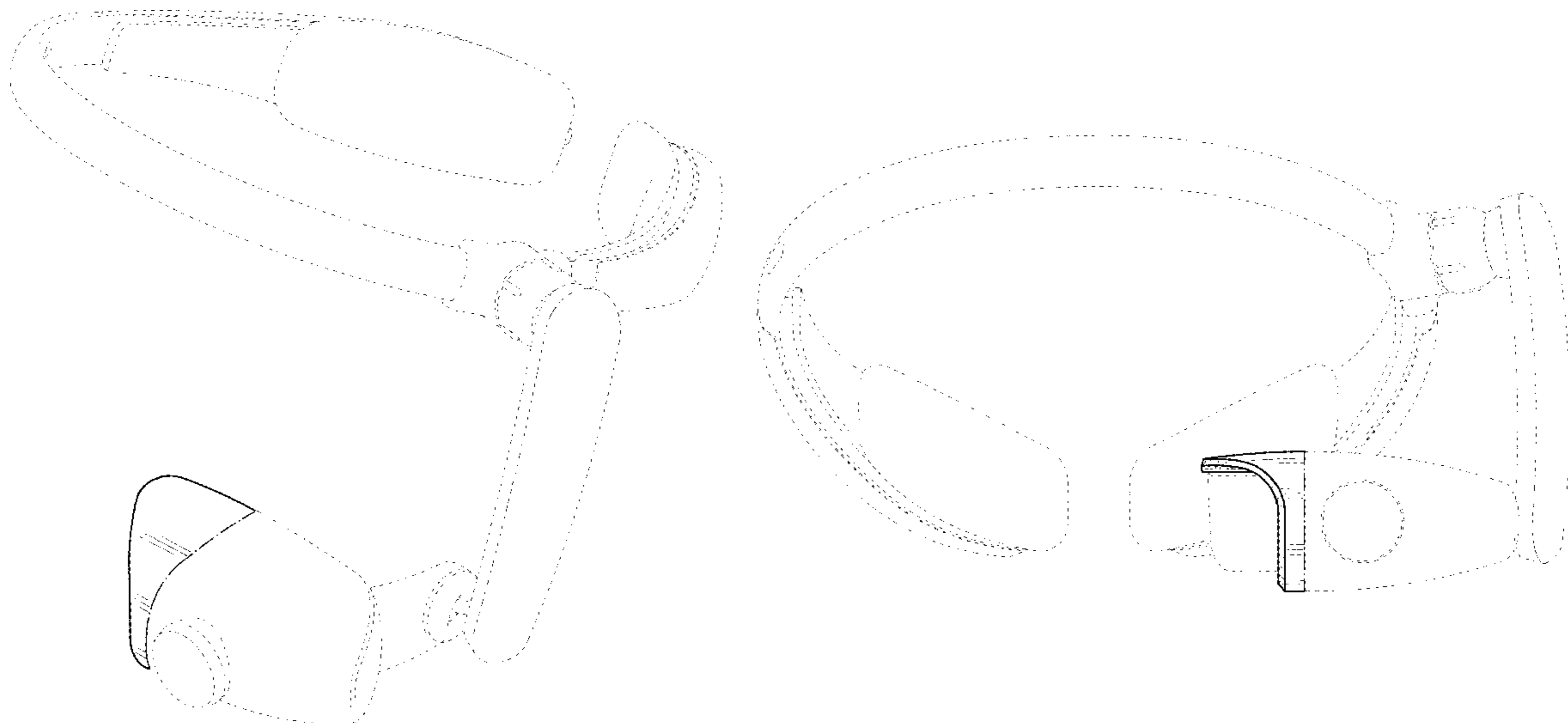

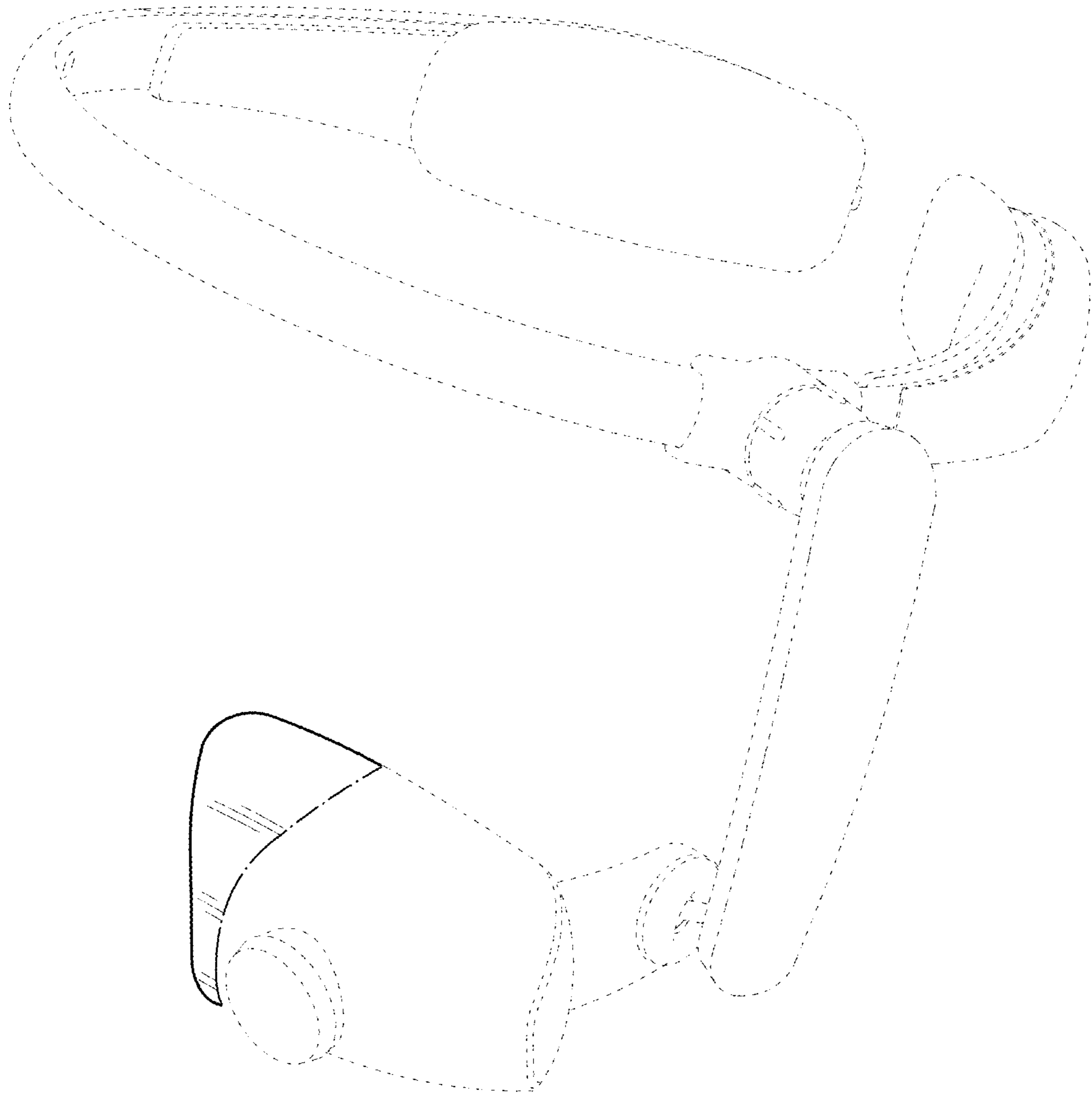

FIG. 1

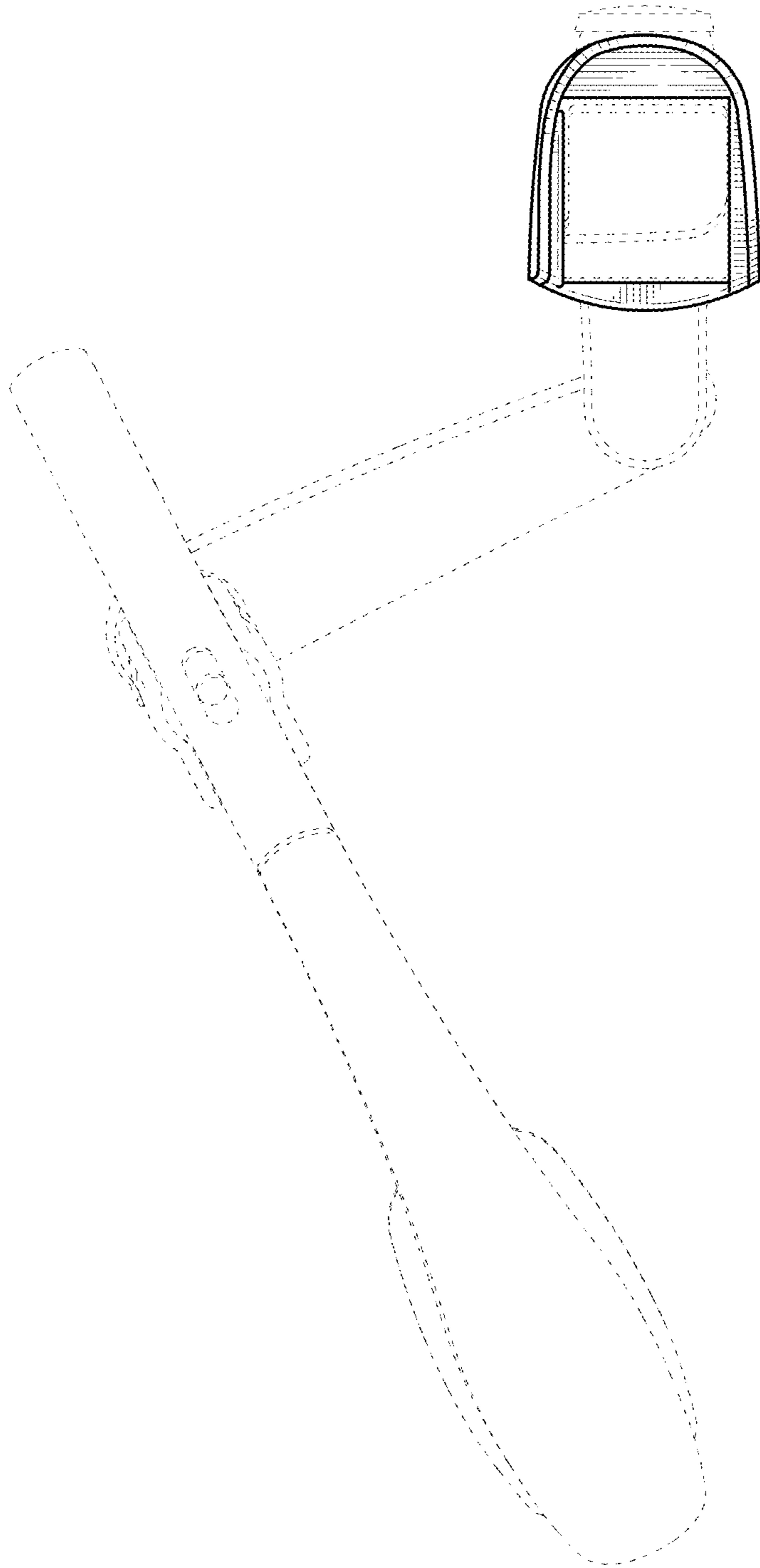

FIG. 2

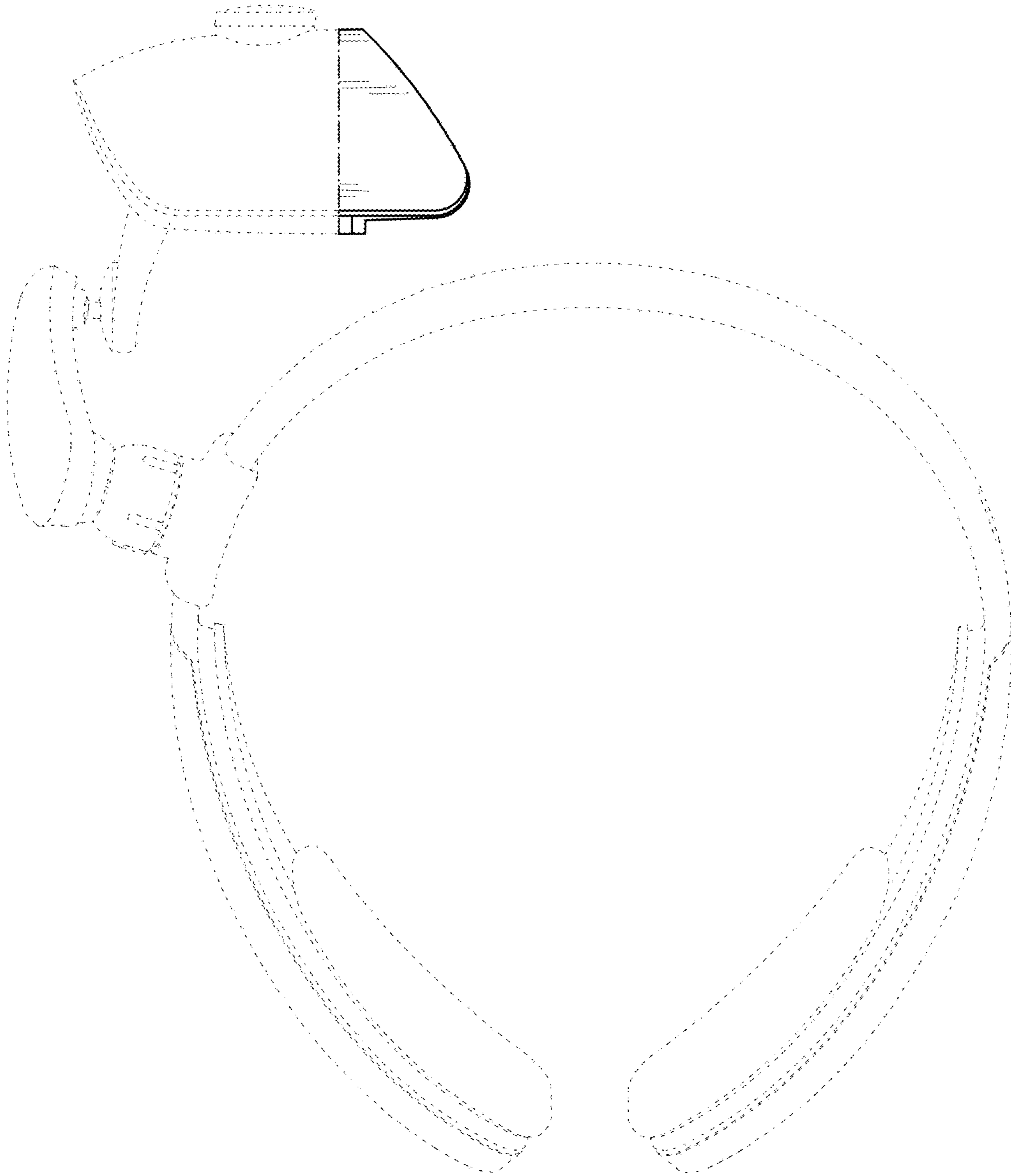

FIG. 3

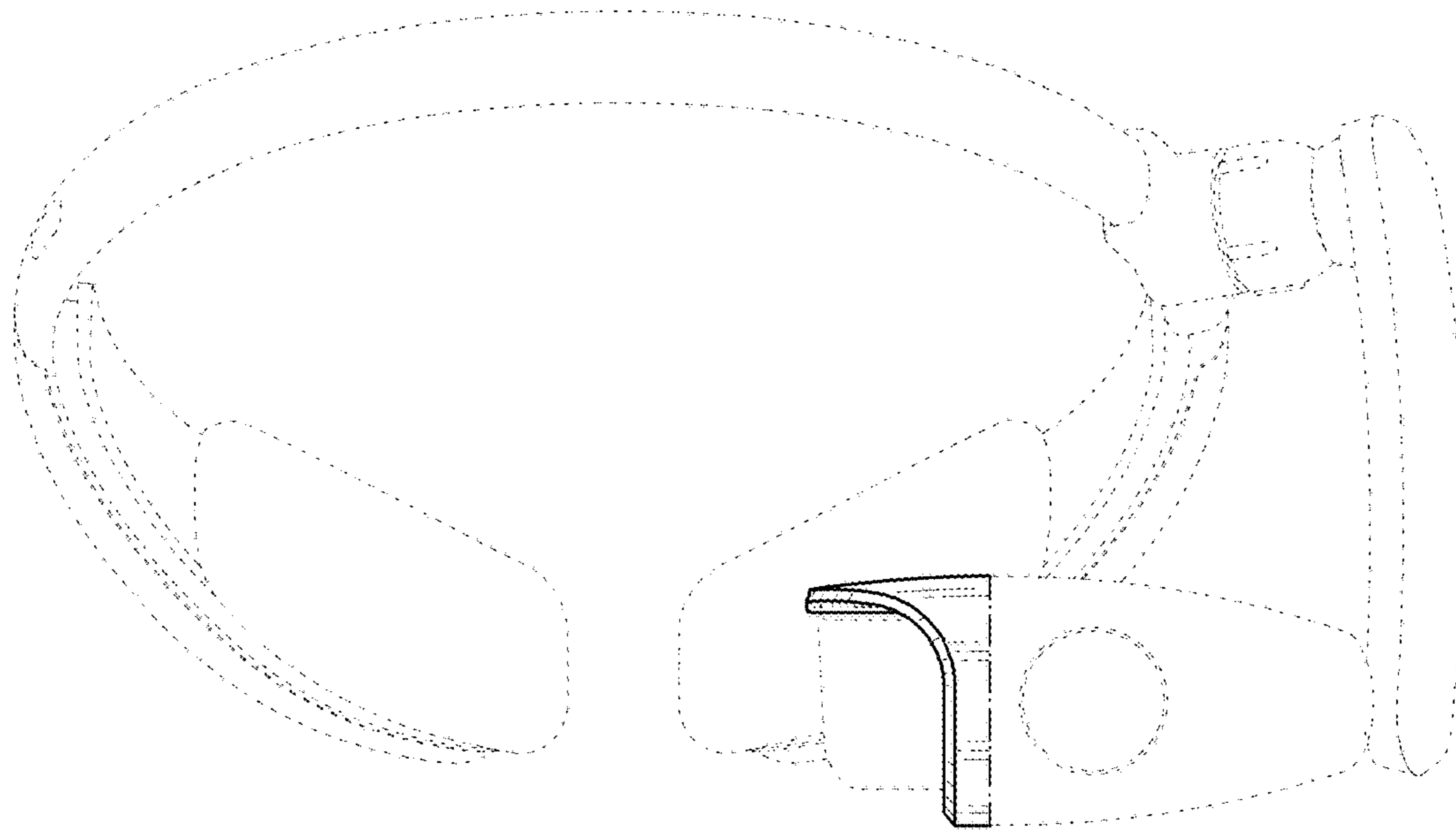

FIG. 4

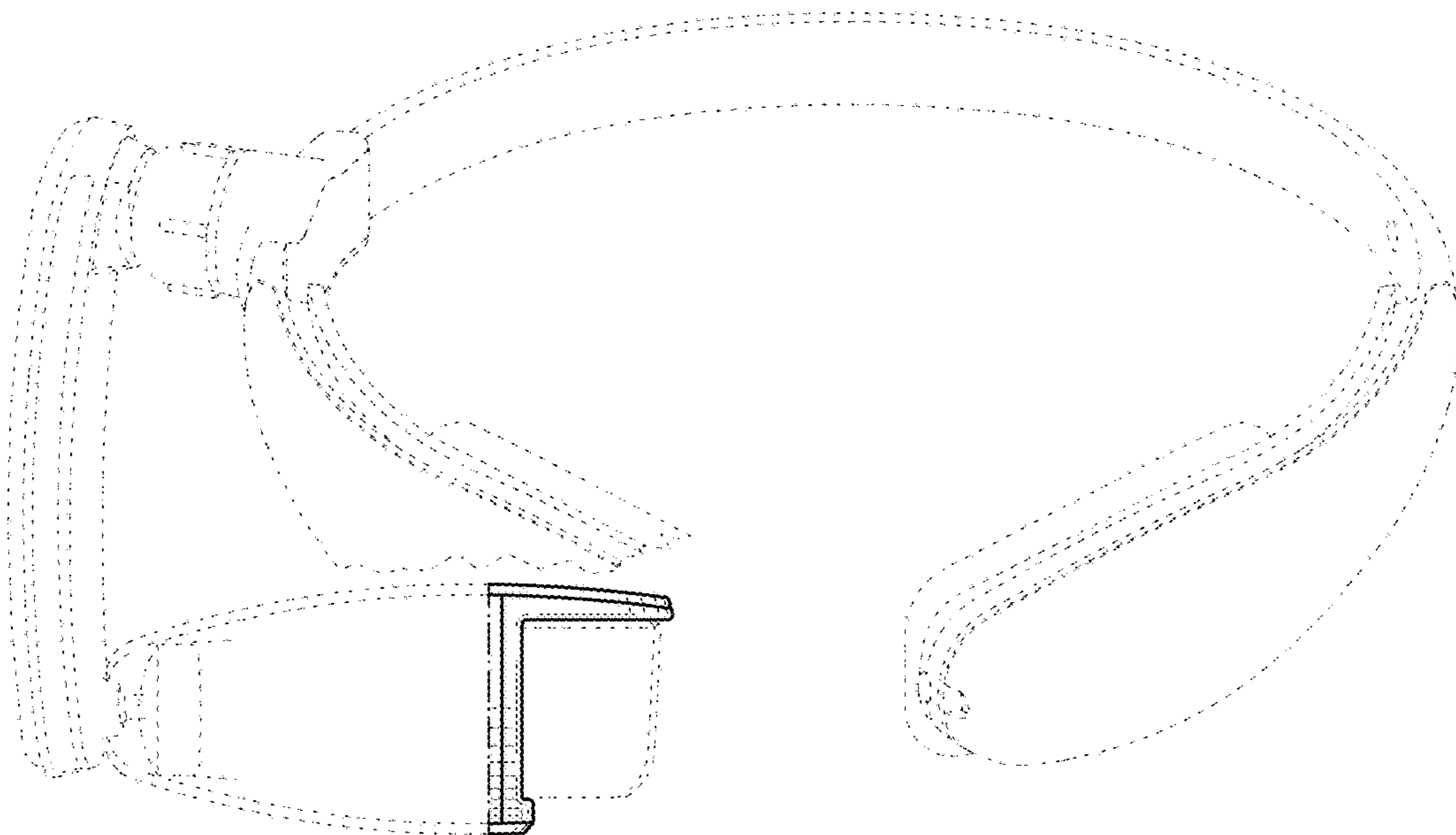

FIG. 5

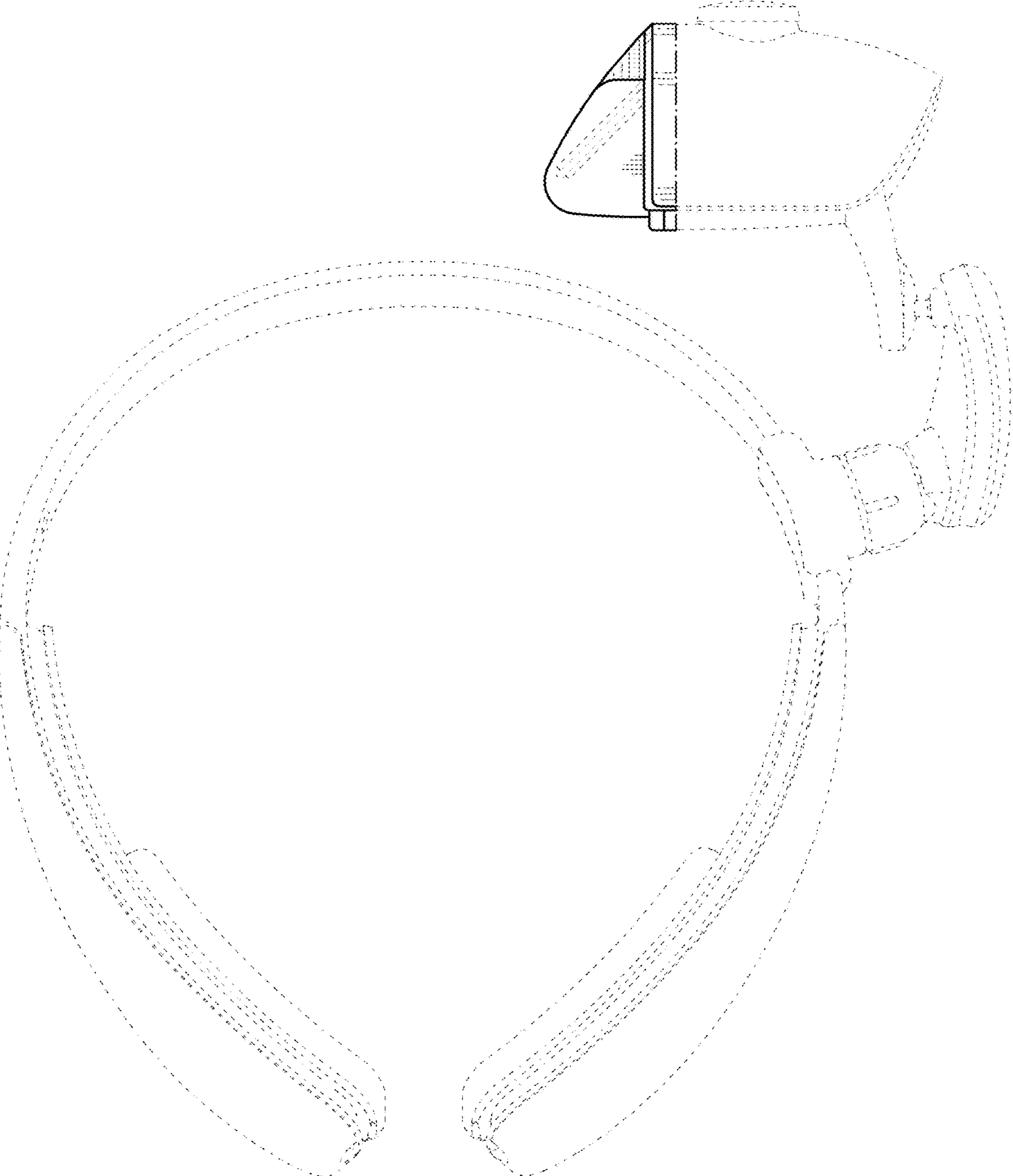

FIG. 6

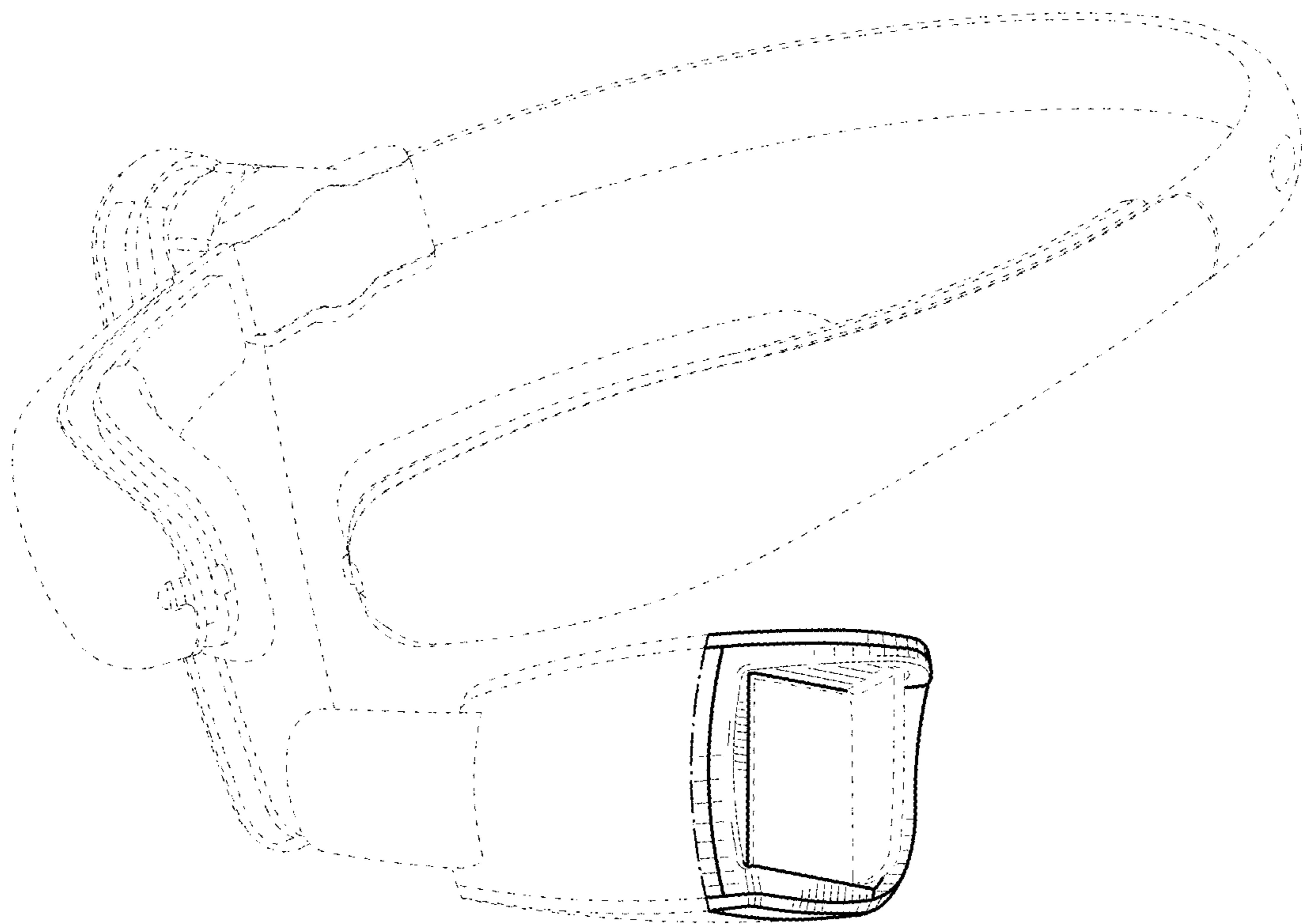

FIG. 7