

US00D778803S

(12) **United States Design Patent** (10) **Patent No.:** **US D778,803 S**
Faure et al. (45) **Date of Patent:** **** *Feb. 14, 2017**

(54) **AIRPLANE**
(71) Applicant: **Astrium SAS**, Suresnes (FR)
(72) Inventors: **Benjamin Faure**, Saint André de Cubzac (FR); **Angélique Santerre**, Listrac-Médoc (FR); **Jean Philippe Dutheil**, Martignas-sur-Jalle (FR); **Christophe Chavagnac**, Paris (FR); **Eugénio Ferreira**, Paris (FR); **Thierry Pichard**, Suresnes (FR)
(73) Assignee: **AIRBUS DEFECE AND SPACE SAS**, Les Mureaux (FR)

D326,842 S * 6/1992 Buchsel et al. D12/319
D426,804 S * 6/2000 Birrenbach D12/319
D491,875 S * 6/2004 Eatkins et al. D12/319
D499,688 S * 12/2004 Atkinson et al. D12/319
D500,281 S * 12/2004 Hayashi et al. D12/319
D515,012 S * 2/2006 Eatkins et al. D12/319
D515,013 S * 2/2006 Eatkins et al. D12/319
D516,995 S * 3/2006 Eatkins et al. D12/319
D517,467 S * 3/2006 Vigneron et al. D12/319
D529,857 S * 10/2006 Eakins et al. D12/319
D530,658 S * 10/2006 Vigneron et al. D12/319
D531,954 S * 11/2006 Eakins et al. D12/319
D537,029 S * 2/2007 Eakins et al. D12/319
D576,938 S * 9/2008 Moon D12/343
D589,867 S * 4/2009 Chesne et al. D12/343
D589,868 S * 4/2009 Matharan et al. D12/343

(*) Notice: This patent is subject to a terminal disclaimer.
(**) Term: **14 Years**

(Continued)
Primary Examiner — Robert M Spear
Assistant Examiner — Marissa J Cash
(74) *Attorney, Agent, or Firm* — Pearne & Gordon LLP

(21) Appl. No.: **29/498,511**
(22) Filed: **Aug. 5, 2014**

(57) **CLAIM**

We claim the ornamental design for an airplane, as shown and described herein.

(30) **Foreign Application Priority Data**
Feb. 6, 2014 (EM) 002399592-0001
(51) **LOC (10) Cl.** **12-07**
(52) **U.S. Cl.**
USPC **D12/319**; D12/342
(58) **Field of Classification Search**
USPC D12/319, 322, 323, 326, 327, 328, 329, D12/330, 339, 341, 342, 343, 344, 345; D21/436, 438, 439, 440, 441, 446, 447, D21/448, 449, 450, 453
CPC B64C 39/00; B64C 30/00; B64C 29/00
See application file for complete search history.

DESCRIPTION

FIG. 1 is a front perspective view of the airplane of the new design, from above the airplane.
FIG. 2 is a left-side view of the airplane.
FIG. 3 is a front view of the airplane.
FIG. 4 is a rear view of the airplane.
FIG. 5 is a top view of the airplane.
FIG. 6 is a bottom view of the airplane; and,
FIG. 7 is a rear perspective view of the airplane.
The broken lines shown on the drawings illustrate portions of the airplane that form no part of the claimed design.
FIGS. 1-7 illustrate different views of the airplane of the new design, which has left-to-right mirror-image symmetry.

(56) **References Cited**
U.S. PATENT DOCUMENTS
D231,605 S * 5/1974 Frajola D12/337
D259,411 S * 6/1981 Miller et al. D12/341

1 Claim, 6 Drawing Sheets

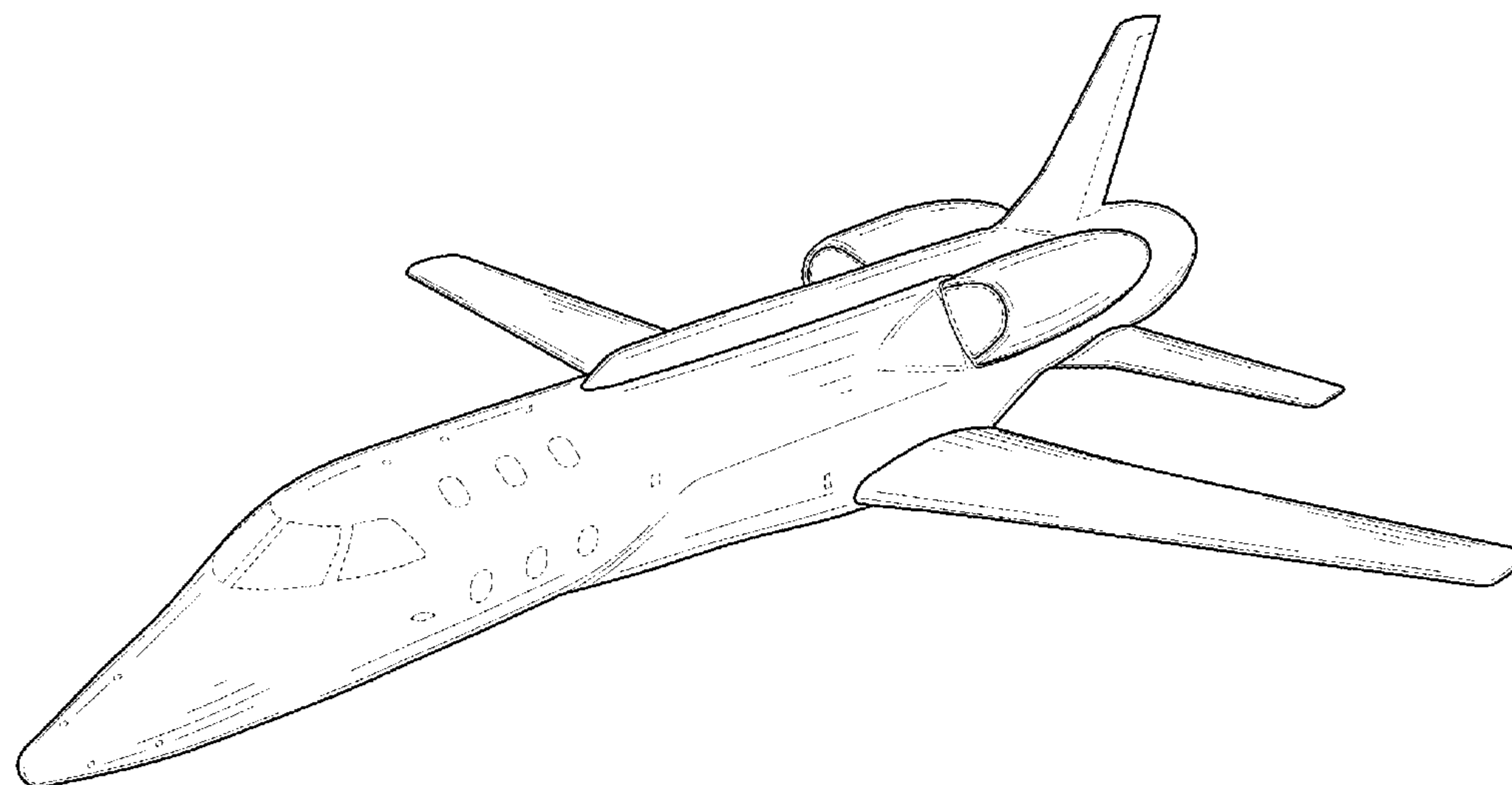

(56)

References Cited

U.S. PATENT DOCUMENTS

D598,361	S	*	8/2009	Beaunis et al.	D12/343
D612,792	S	*	3/2010	Guering	D12/343
D617,724	S	*	6/2010	Saint-Jalmes et al.	D12/343
D619,076	S	*	7/2010	Guering	D12/343
D624,479	S	*	9/2010	Guering	D12/343
D624,480	S	*	9/2010	Guering	D12/343
D629,349	S	*	12/2010	Hwang	D12/319
D634,696	S	*	3/2011	Saint-Jalmes et al.	D12/345
D674,734	S	*	1/2013	Fujino et al.	D12/345
D702,622	S	*	4/2014	Klimov et al.	D12/319
D731,949	S	*	6/2015	Matsuo	D12/319
D732,458	S	*	6/2015	Dutertre	D12/319
D733,029	S	*	6/2015	Dutertre	D12/319
D733,031	S	*	6/2015	Horlin et al.	D12/345
2010/0276545	A1	*	11/2010	Chavagnac et al.	244/158.9

* cited by examiner

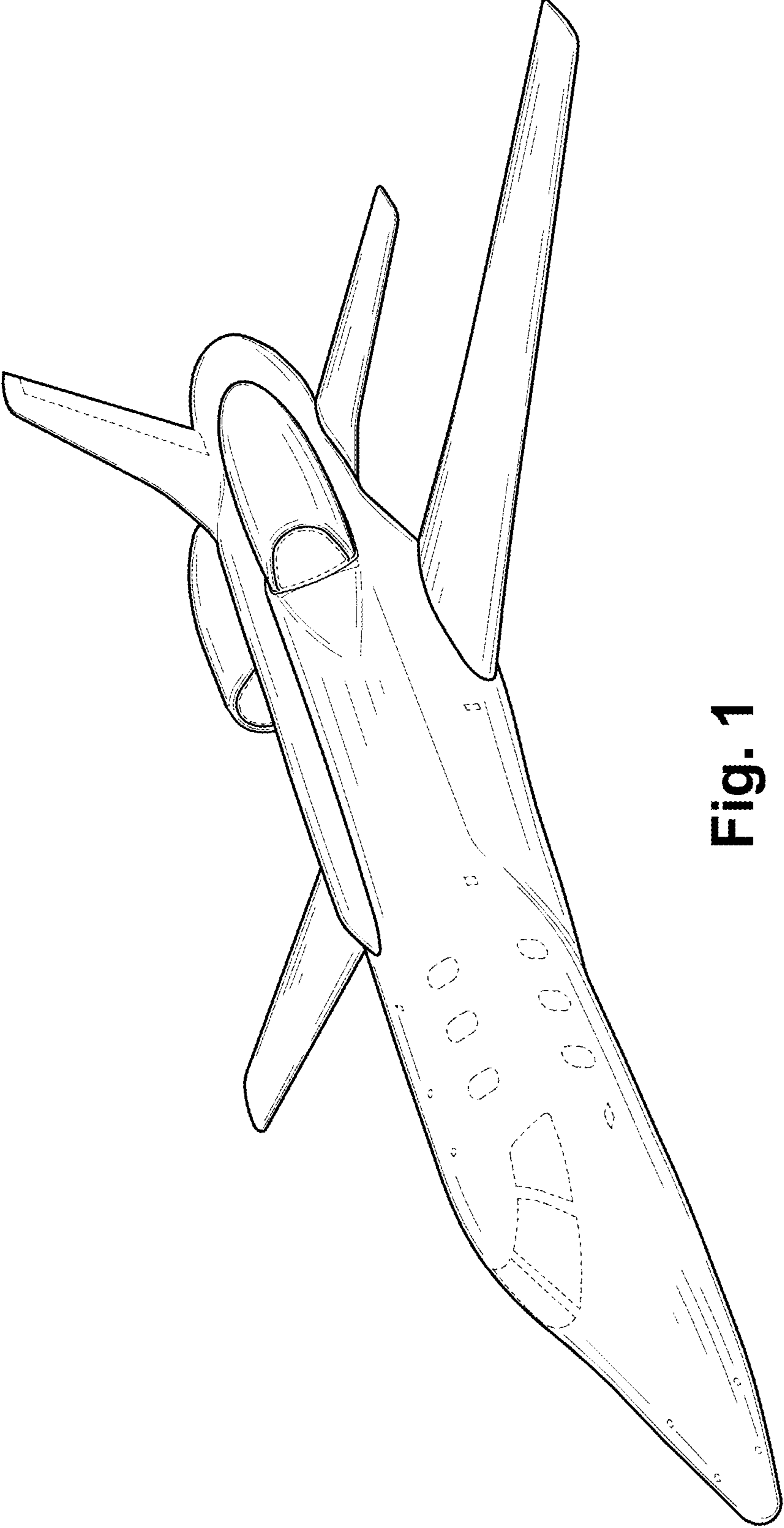

Fig. 1

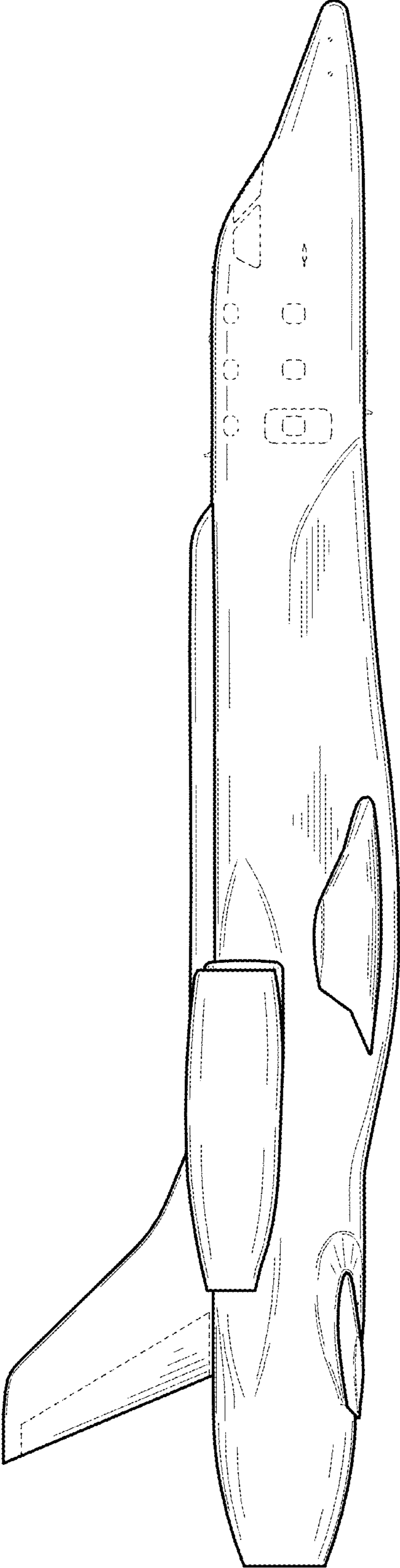

Fig. 2

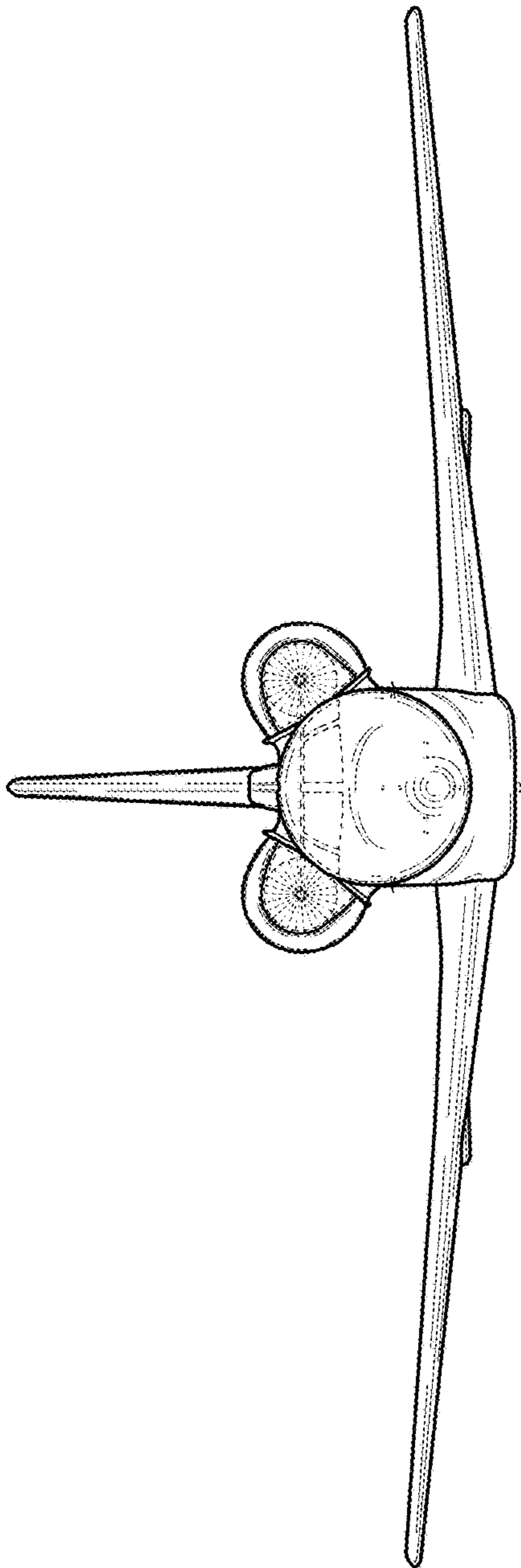

Fig. 3

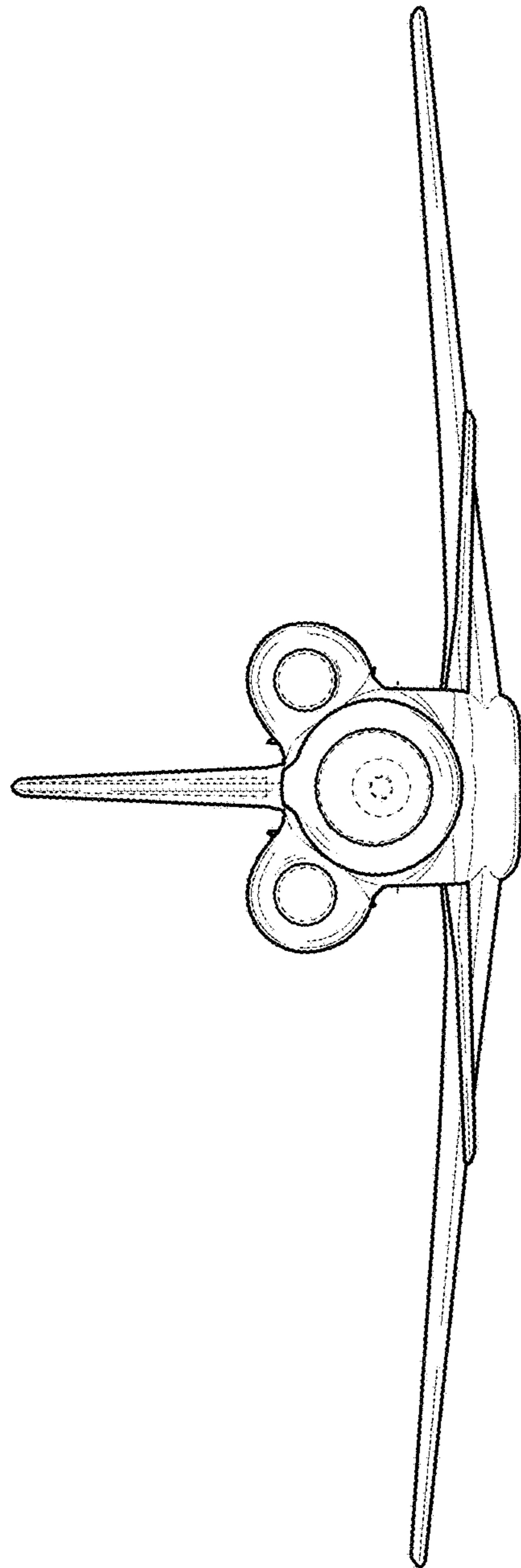

Fig. 4

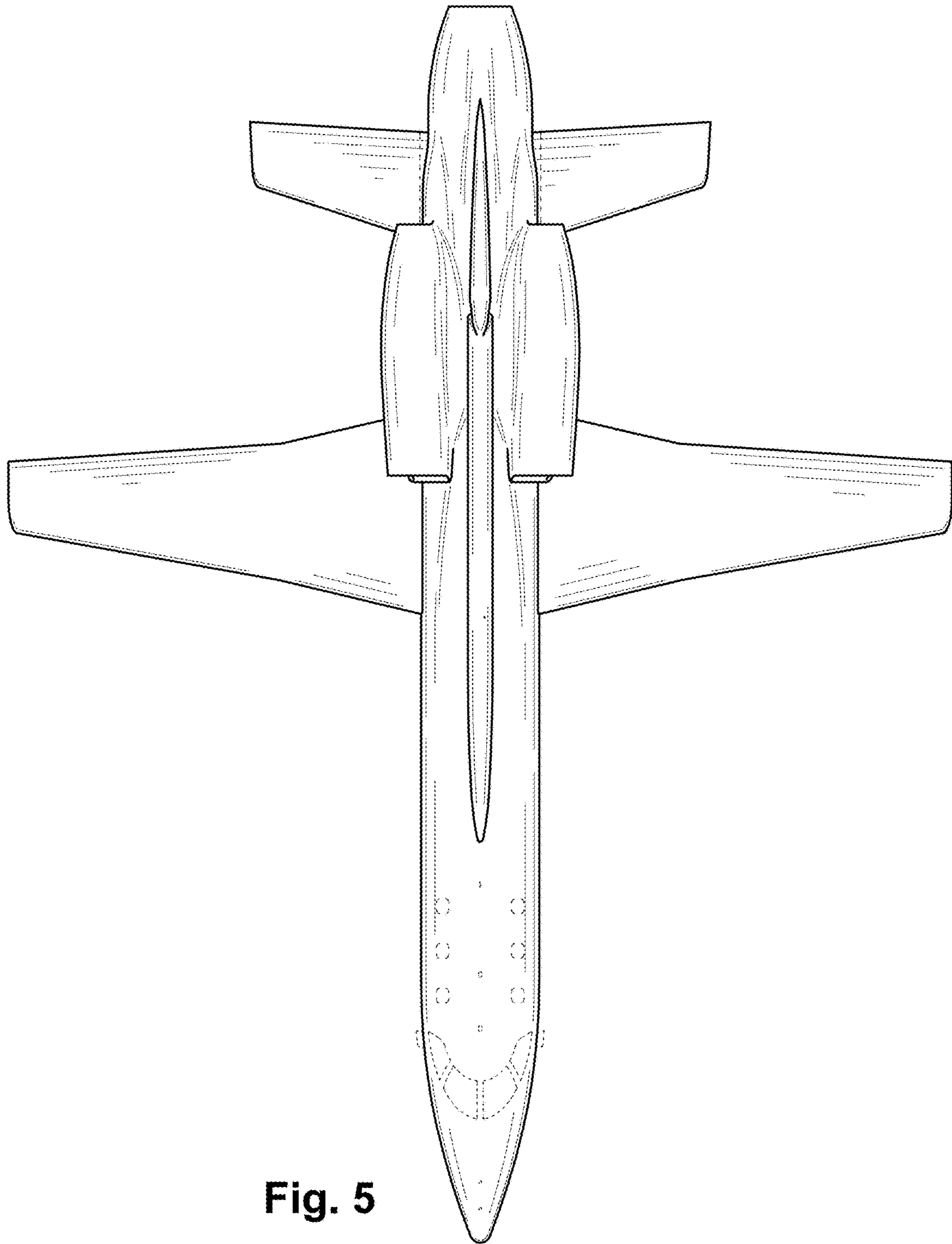

Fig. 5

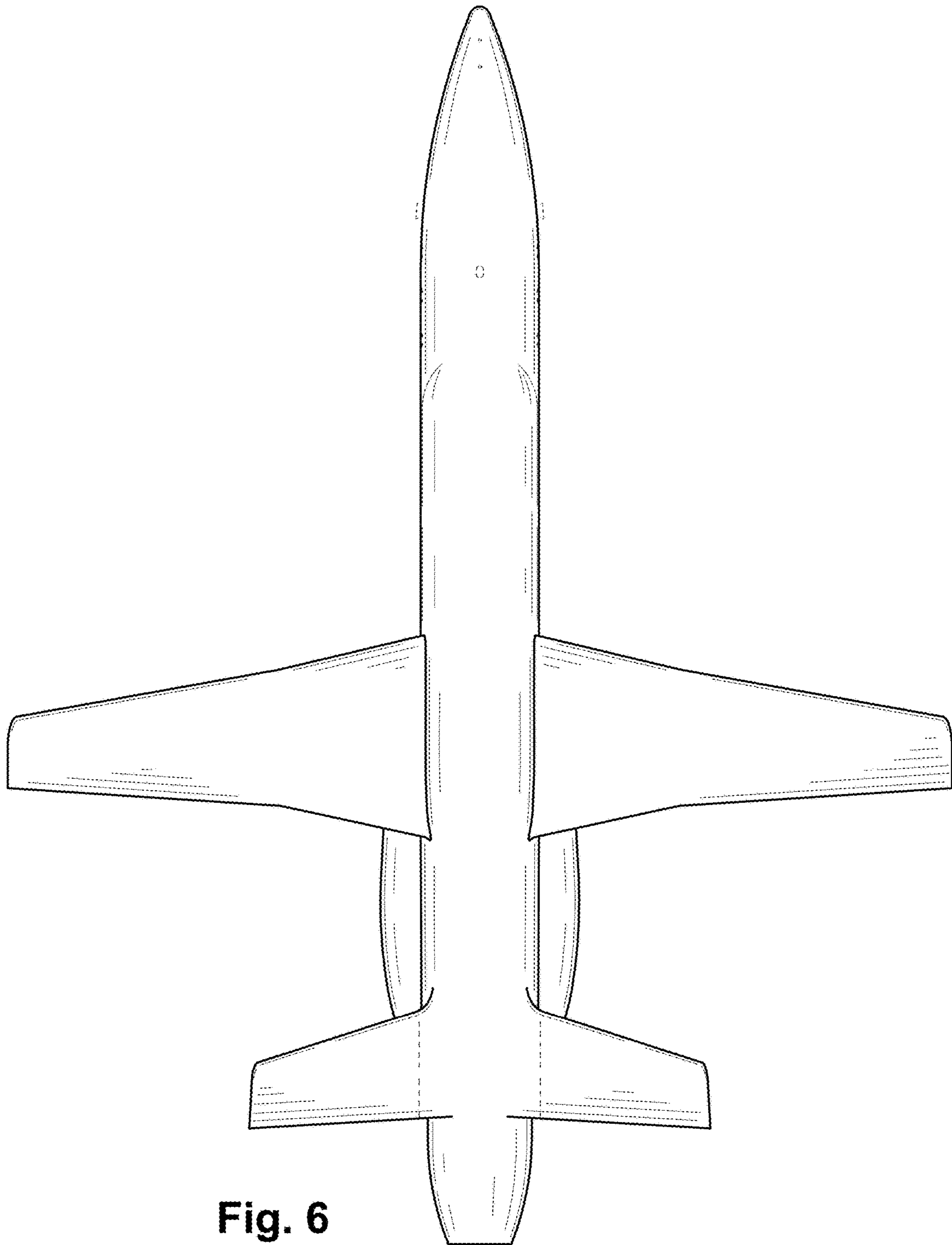

Fig. 6

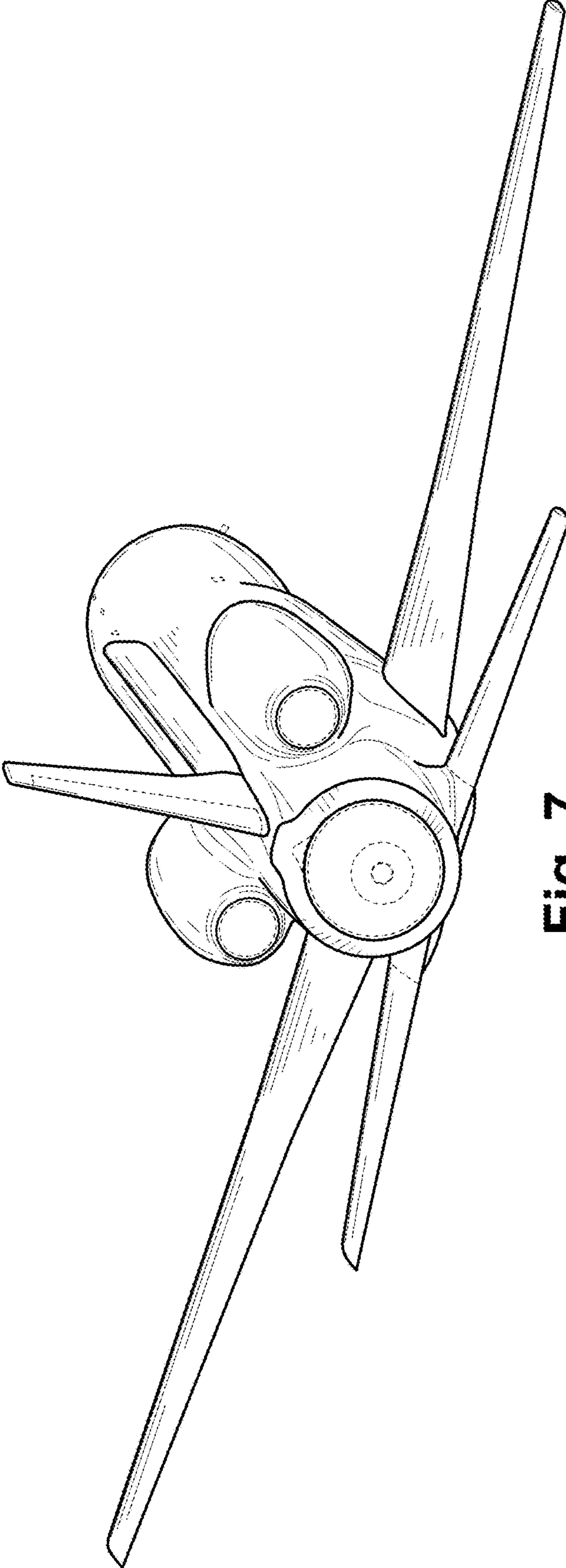

Fig. 7

UNITED STATES PATENT AND TRADEMARK OFFICE
CERTIFICATE OF CORRECTION

PATENT NO. : D778,803 S
APPLICATION NO. : 29/498511
DATED : February 14, 2017
INVENTOR(S) : Benjamin Faure et al.

Page 1 of 1

It is certified that error appears in the above-identified patent and that said Letters Patent is hereby corrected as shown below:

On the Title Page

Item (73) Assignee:

At Column 1, in the name of the Assignee, delete "AIRBUS DEFECE AND SPACE SAS" and insert -
-AIRBUS DEFENCE AND SPACE SAS--

Signed and Sealed this
Twenty-second Day of May, 2018

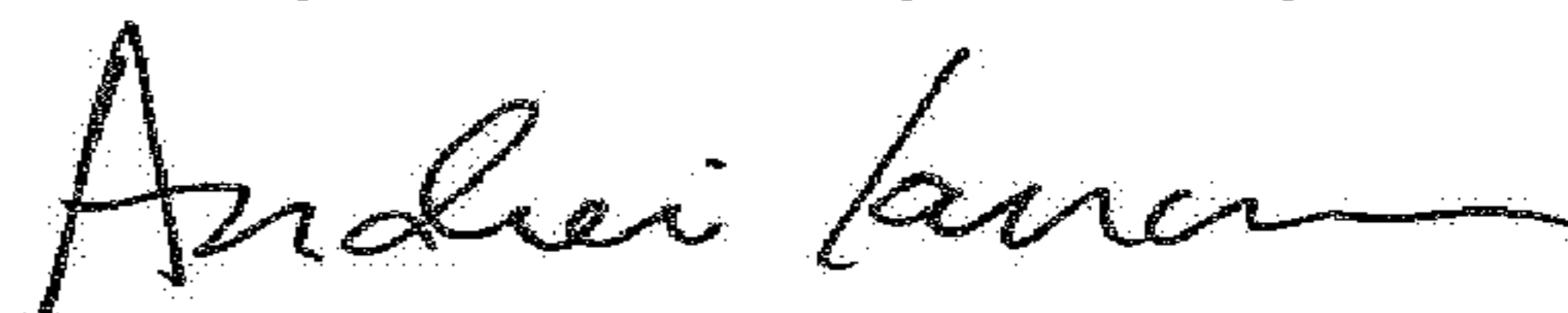

Andrei Iancu
Director of the United States Patent and Trademark Office