



US00D778793S

(12) **United States Design Patent**
Ding

(10) **Patent No.:** **US D778,793 S**

(45) **Date of Patent:** **** Feb. 14, 2017**

(54) **STEERING WHEEL**

(71) Applicant: **Thunder Power Hong Kong Ltd.,**
Central (HK)

(72) Inventor: **Jia-Wei Ding,** Taipei (TW)

(73) Assignee: **THUNDER POWER HONG KONG LTD.,** Central (HK)

(**) Term: **15 Years**

(21) Appl. No.: **29/548,498**

(22) Filed: **Dec. 14, 2015**

(51) **LOC (10) Cl.** **12-16**

(52) **U.S. Cl.**
USPC **D12/176**

(58) **Field of Classification Search**
USPC D12/175, 176; 74/552, 558, 558.5
CPC B60R 21/203; B60R 21/05; B62D 1/04
See application file for complete search history.

(56) **References Cited**

U.S. PATENT DOCUMENTS

D514,485 S * 2/2006 Juraschek D12/176
D515,479 S * 2/2006 Yamazaki D12/176

D516,477 S * 3/2006 Tomasson D12/176
D532,351 S * 11/2006 Saito D12/176
D565,485 S * 4/2008 Schafmeister D12/176
D688,606 S * 8/2013 Balko D12/176
D735,099 S * 7/2015 Ritchie D12/176

* cited by examiner

Primary Examiner — Melody N Brown

(74) *Attorney, Agent, or Firm* — Kilpatrick Townsend & Stockton LLP

(57) **CLAIM**

The ornamental design for a steering wheel, as shown and described.

DESCRIPTION

FIG. 1 is a perspective view of an steering wheel;
FIG. 2 is a front view thereof;
FIG. 3 is a right side view thereof;
FIG. 4 is a left side view thereof;
FIG. 5 is a top view thereof; and,
FIG. 6 is a bottom view thereof.

The broken lines in the figures are for illustrative purposes only, and form no part of the claimed design.

1 Claim, 5 Drawing Sheets

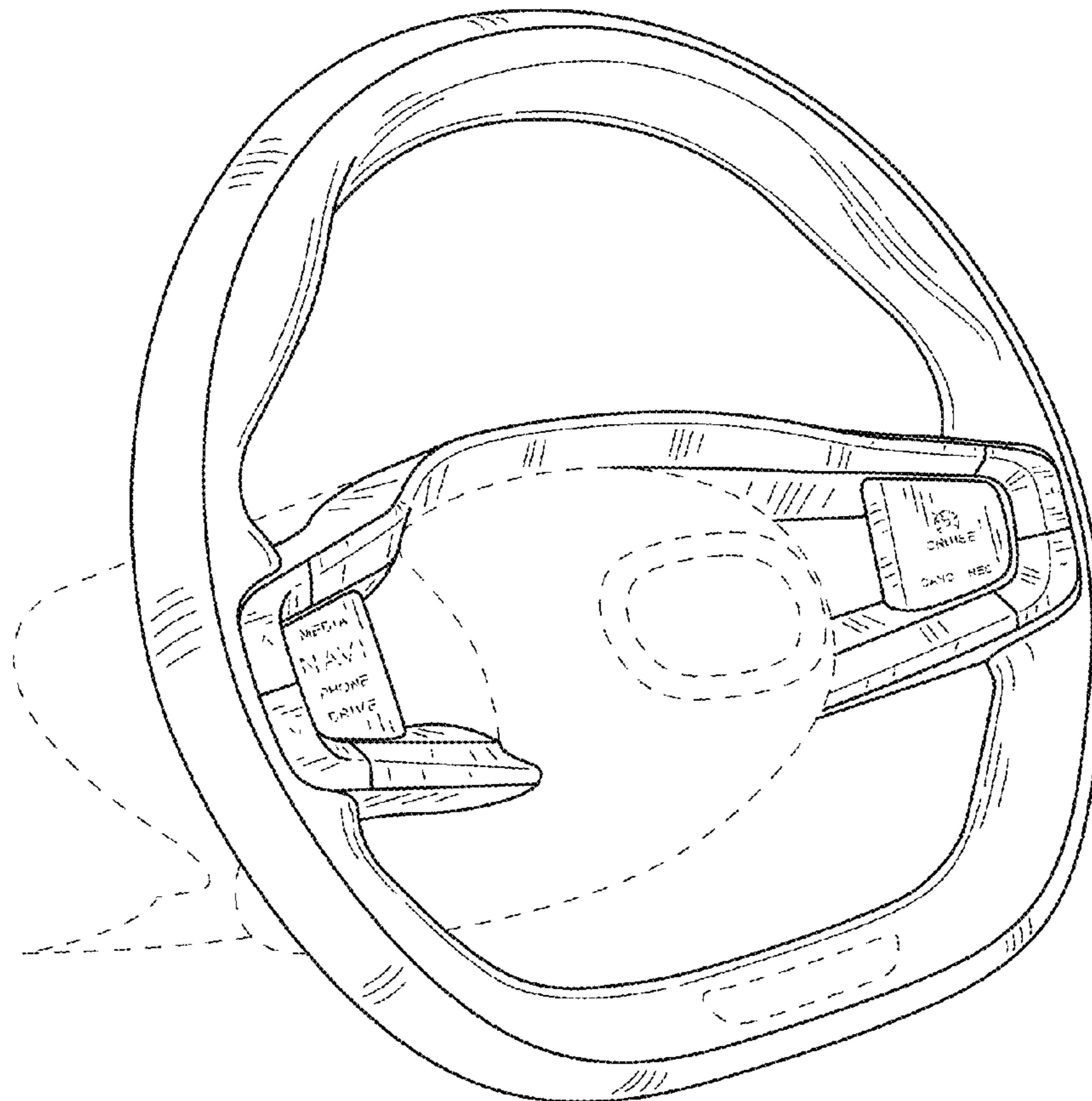

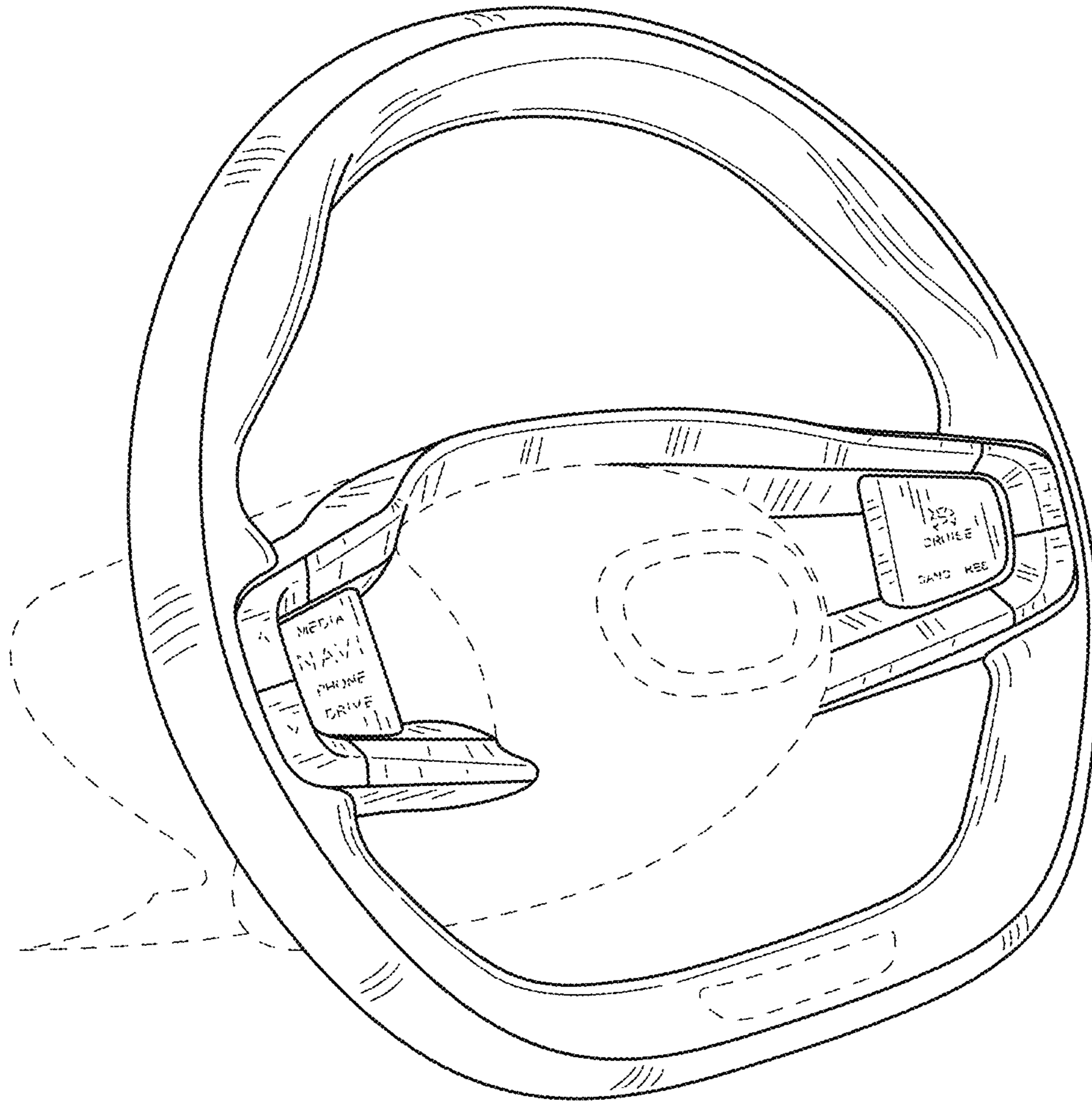

FIG.1

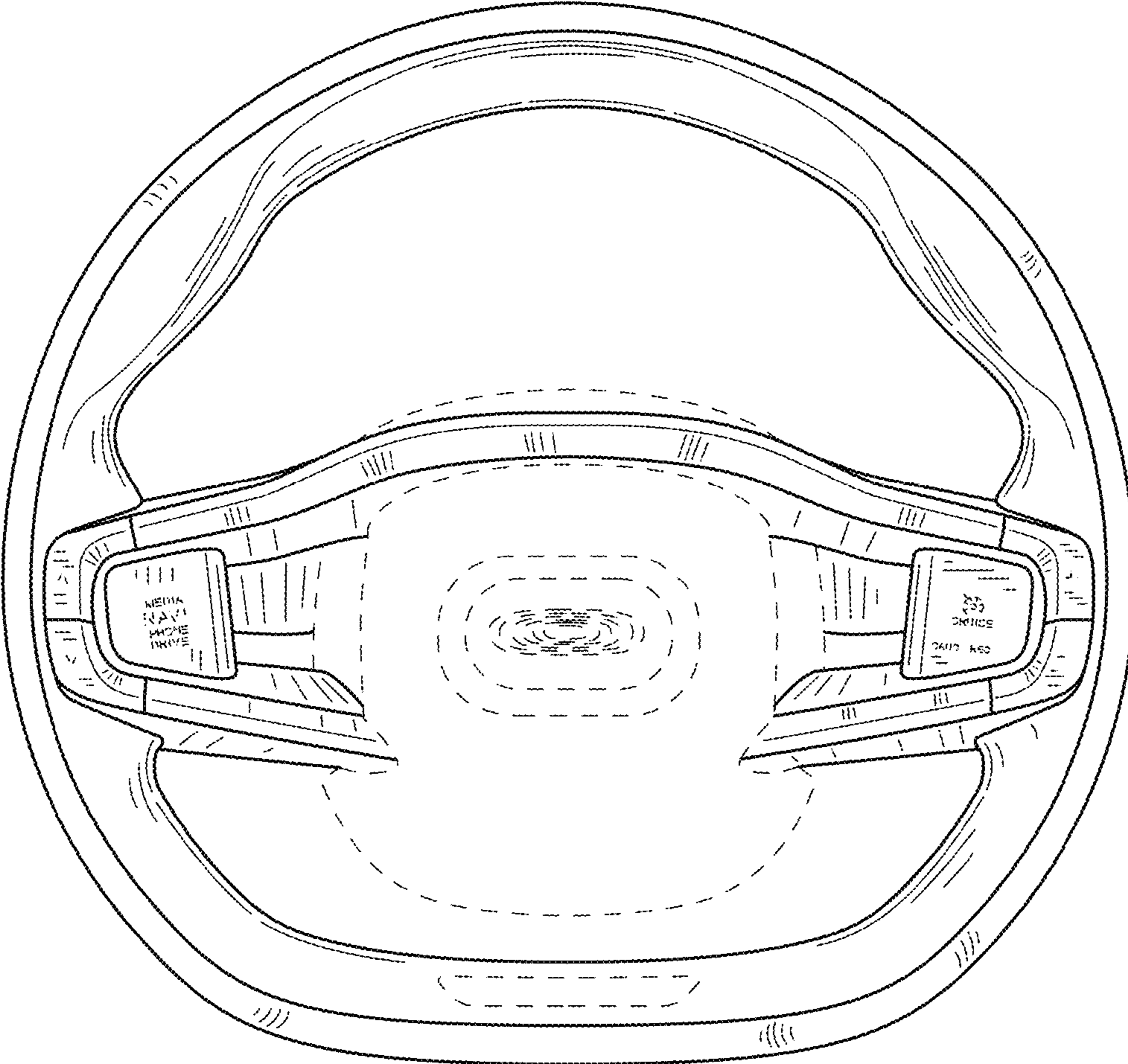

FIG.2

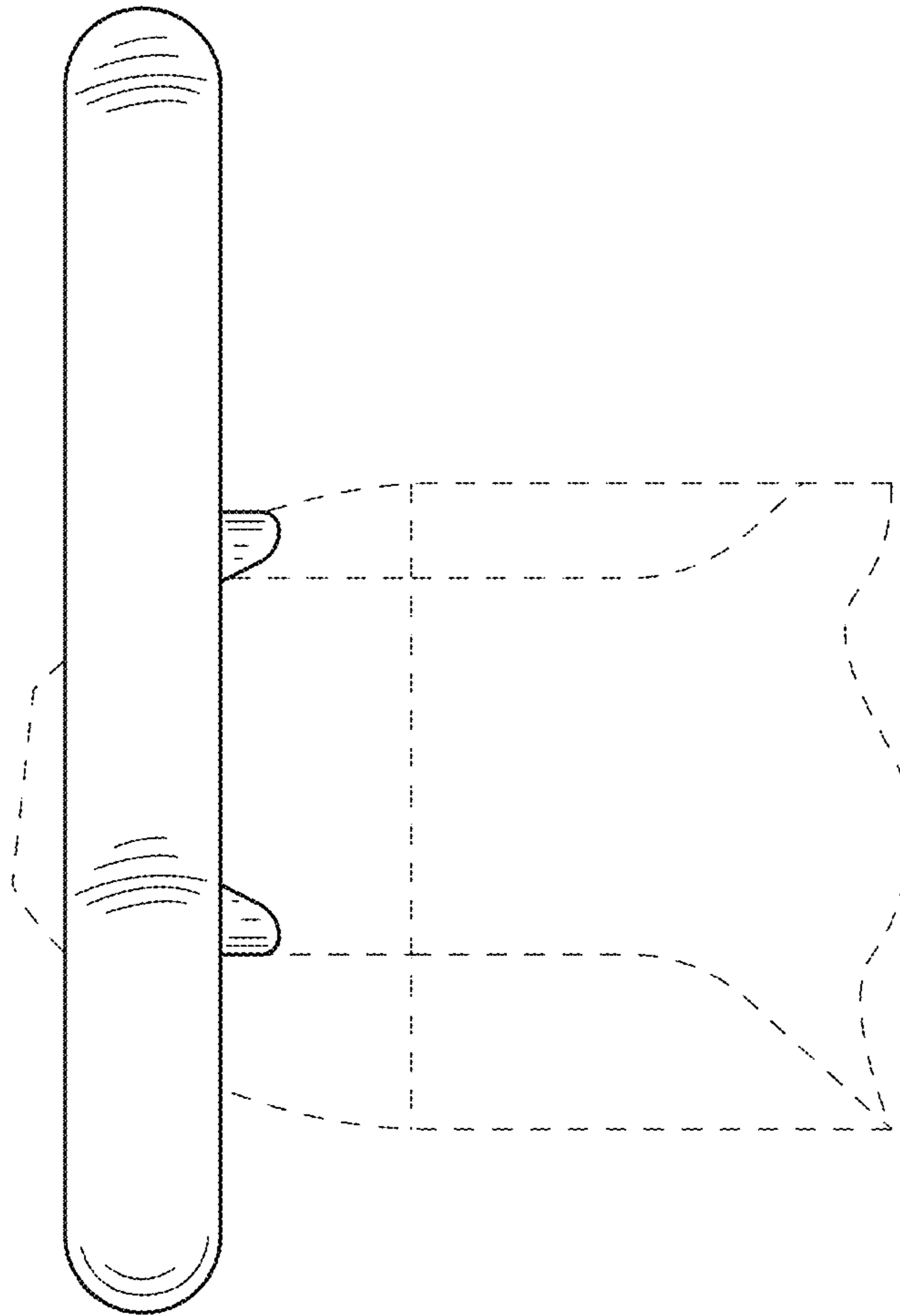

FIG.3

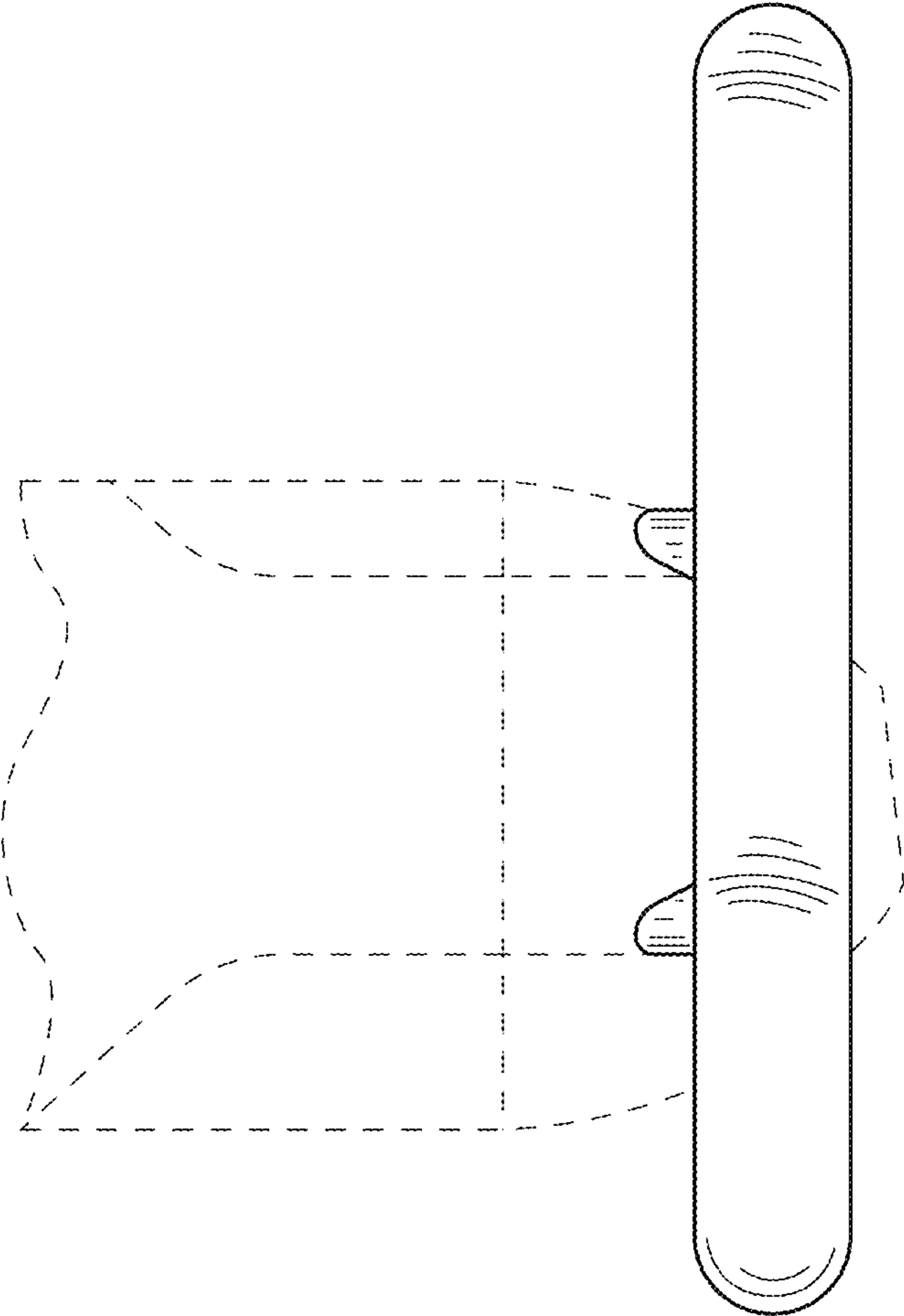

FIG.4

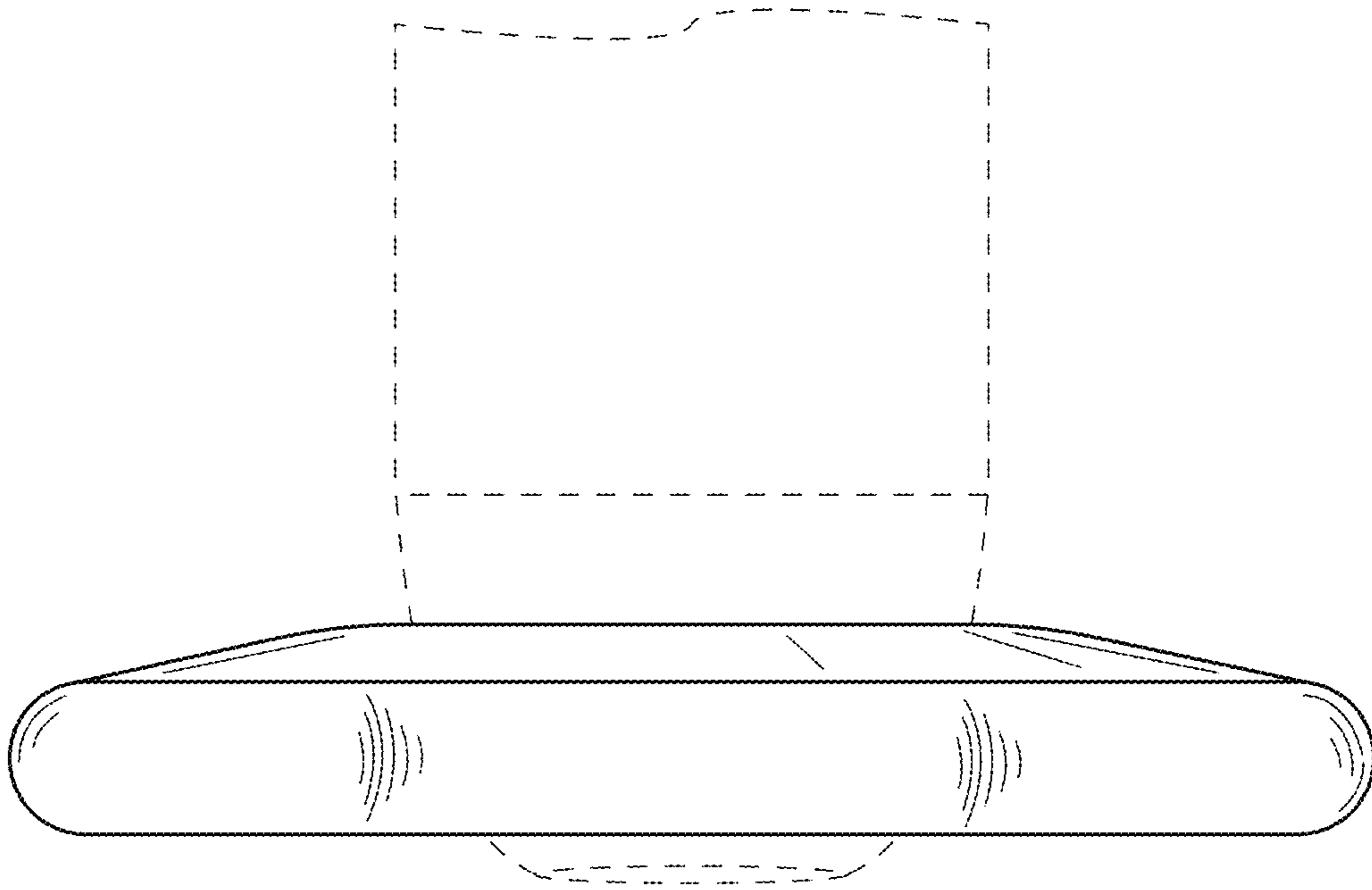

FIG. 5

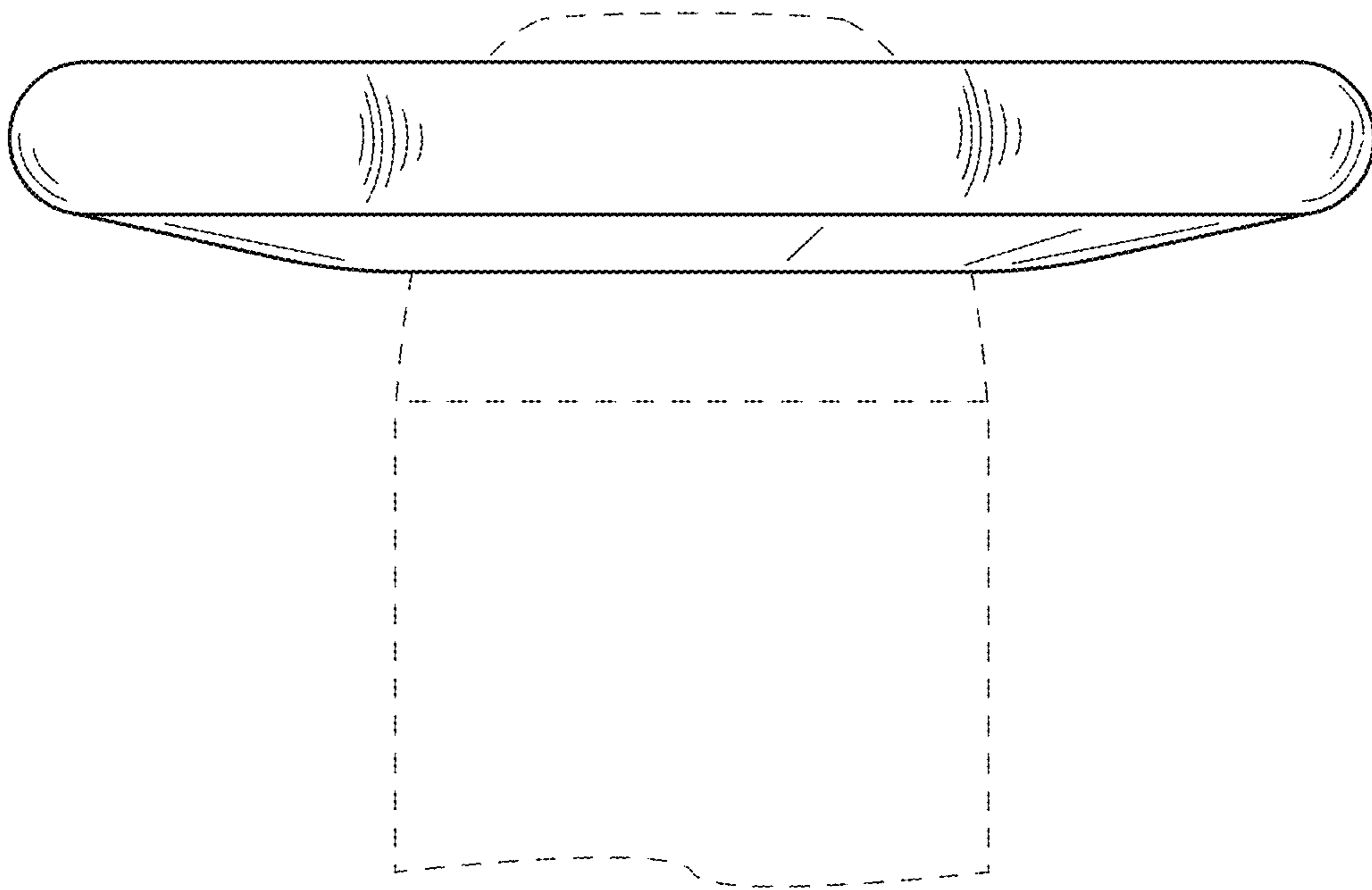

FIG. 6