



US00D778522S

(12) **United States Design Patent** (10) **Patent No.:** **US D778,522 S**
Stark (45) **Date of Patent:** **** Feb. 7, 2017**

- (54) **FORK-LIFT TRUCK**
- (71) Applicant: **Dr. Ing. h.c. F. Porsche Aktiengesellschaft, Stuttgart (DE)**
- (72) Inventor: **Stefan Stark, Ludwigsburg (DE)**
- (73) Assignee: **Dr. Ing. h.c. F. Porsche Aktiengesellschaft, Stuttgart (DE)**
- (**) Term: **15 Years**
- (21) Appl. No.: **29/541,603**
- (22) Filed: **Oct. 6, 2015**

D587,423 S	2/2009	Stark	
D587,424 S	2/2009	Stark	
D589,674 S	3/2009	Stark	
D594,173 S *	6/2009	Shibata	D34/34
D601,773 S	10/2009	Stark	
D612,563 S	3/2010	Stark	
D613,474 S *	4/2010	Yakushi	D34/34
D640,855 S *	6/2011	Ruppert	D34/34
D651,783 S *	1/2012	Shibata	D34/34
D657,111 S *	4/2012	Shibata	D34/34
D720,114 S	12/2014	Stark	
D722,214 S *	2/2015	Yakushi	D34/34
D725,863 S *	3/2015	Kazaoka	D34/34
D741,565 S *	10/2015	Schweig	D34/34
D756,056 S *	5/2016	Wen	D34/34
D763,538 S *	8/2016	Sumigama	D34/34
D764,739 S *	8/2016	Molnar	D34/34

* cited by examiner

- (30) **Foreign Application Priority Data**
- Apr. 7, 2015 (EP) 001432926
- (51) **LOC (10) Cl.** **12-05**
- (52) **U.S. Cl.**
- USPC **D34/34**
- (58) **Field of Classification Search**
- USPC D34/34; 187/222, 237; 414/572, 592, 414/631; 180/89.12, 89.13, 89.17
- CPC B66F 9/06; B66F 9/24; B66F 9/12; B66F 9/0755; B66F 9/07572; B66F 17/003
- See application file for complete search history.

Primary Examiner — Cynthia Ramirez
(74) *Attorney, Agent, or Firm* — RatnerPrestia

(57) **CLAIM**

The ornamental design for a fork-lift truck, as shown and described.

DESCRIPTION

FIG. 1 is a top right rear perspective view of a fork-lift truck; FIG. 2 is a top left rear perspective view thereof; FIG. 3 is a right elevation view thereof; FIG. 4 is a left elevation view thereof; FIG. 5 is a rear elevation view thereof; FIG. 6 is a front elevation view thereof; and, FIG. 7 is a top plan view thereof.

The features shown in broken lines in the Figures show portions of the fork-lift truck that form no part of the claimed design.

- (56) **References Cited**
- U.S. PATENT DOCUMENTS
- D470,990 S * 2/2003 Han D34/34
- D471,340 S * 3/2003 Shibata D34/34
- D535,805 S * 1/2007 Stark D21/556
- D584,024 S 12/2008 Stark
- D587,422 S 2/2009 Stark

1 Claim, 6 Drawing Sheets

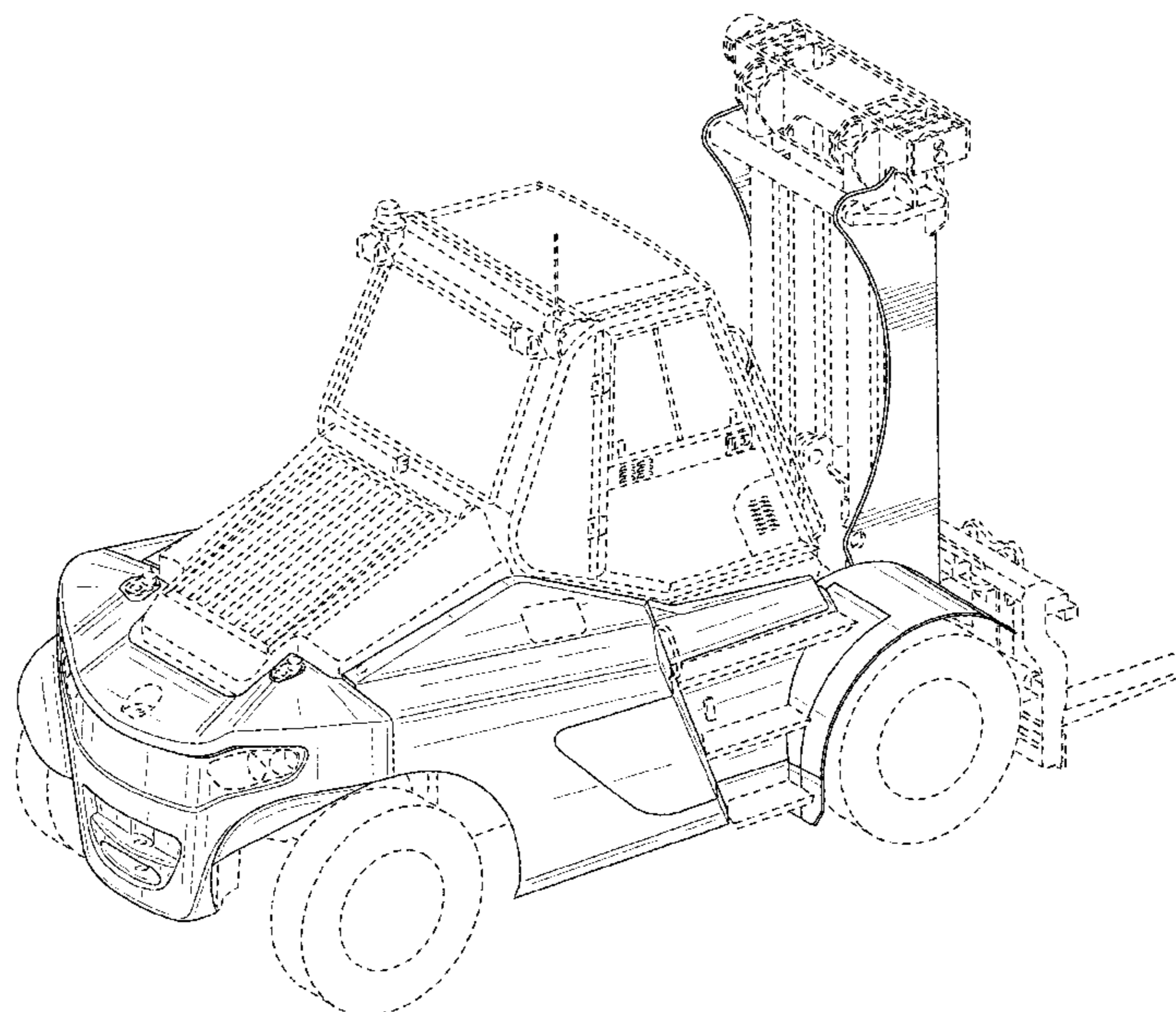
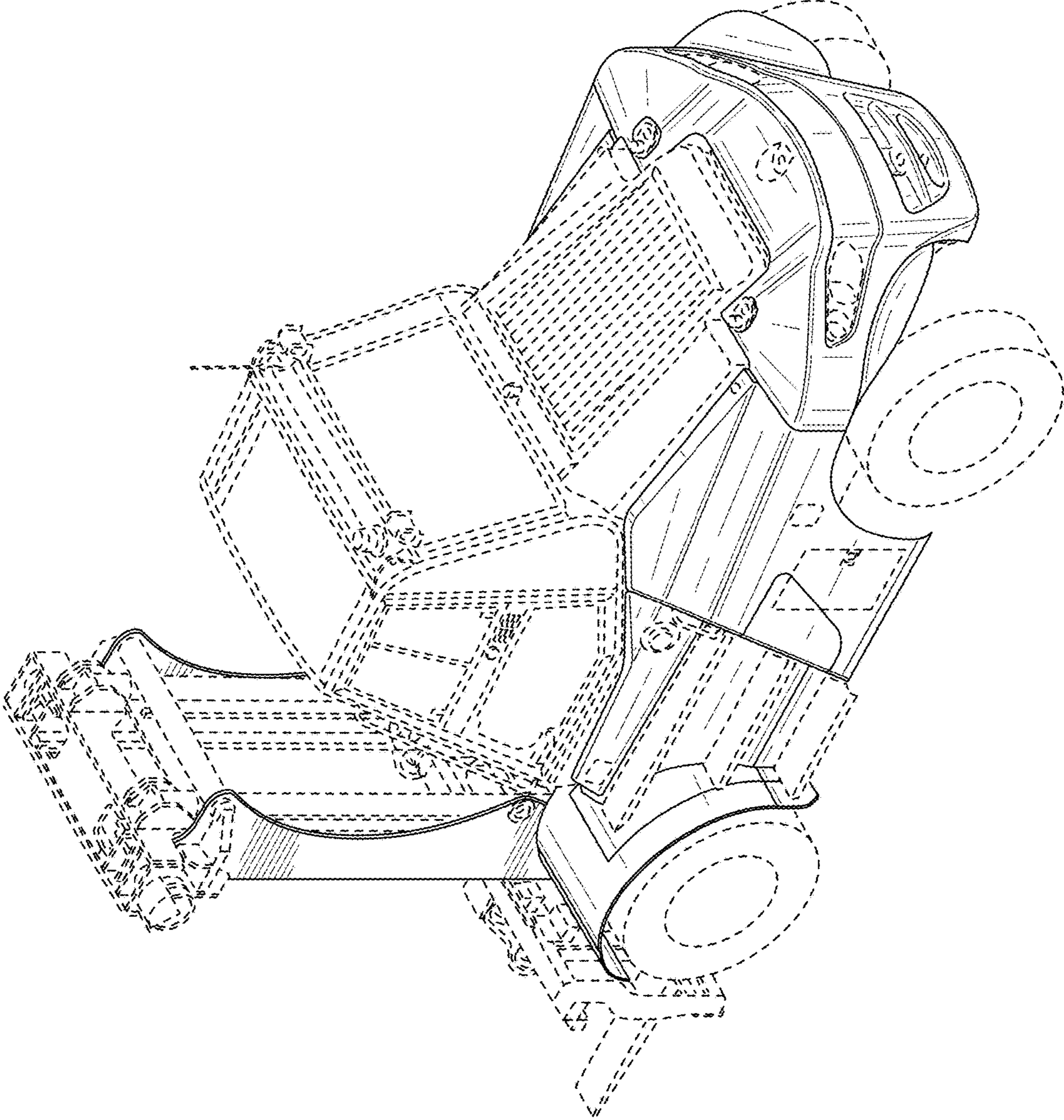

FIG. 2



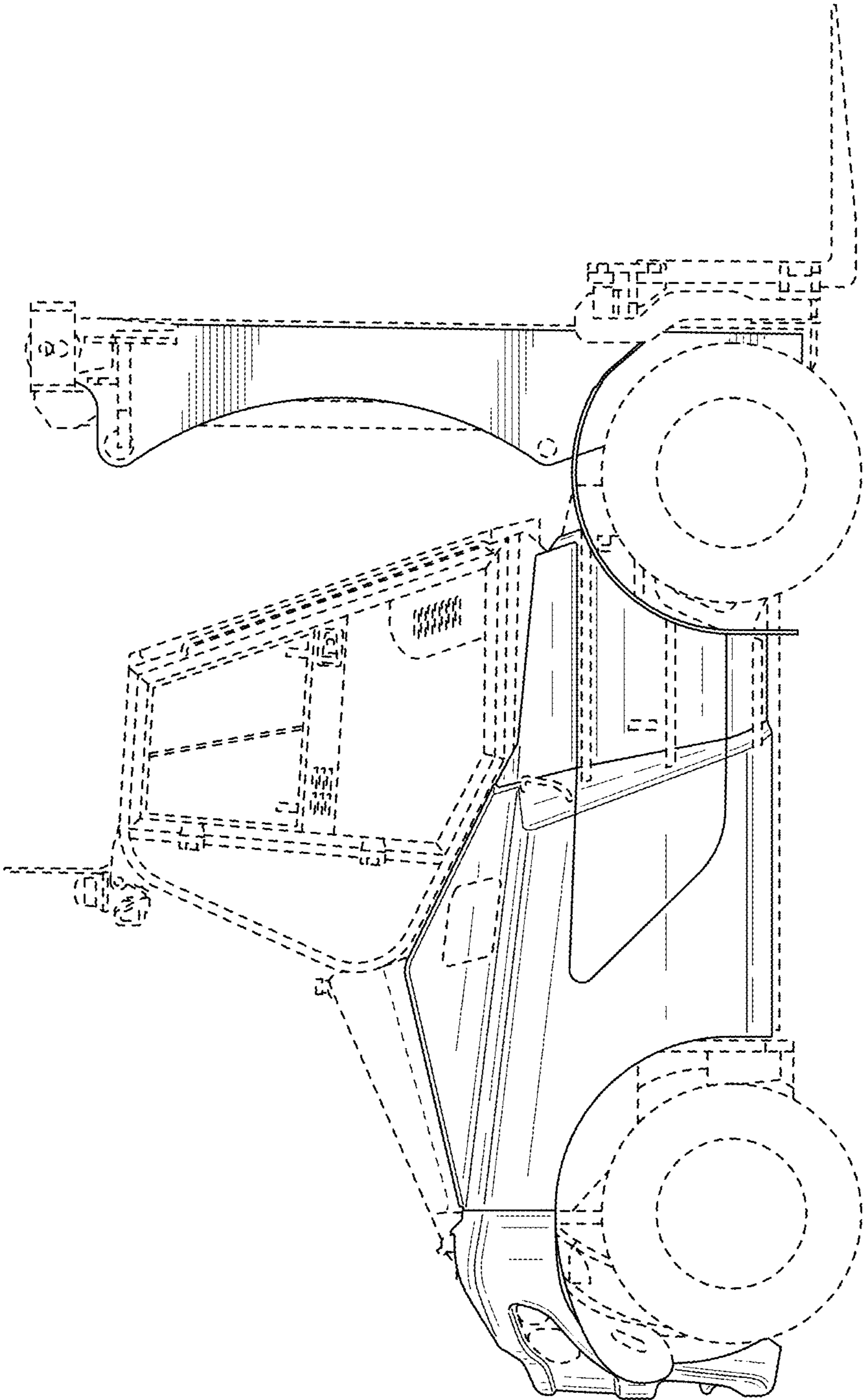

FIG. 3

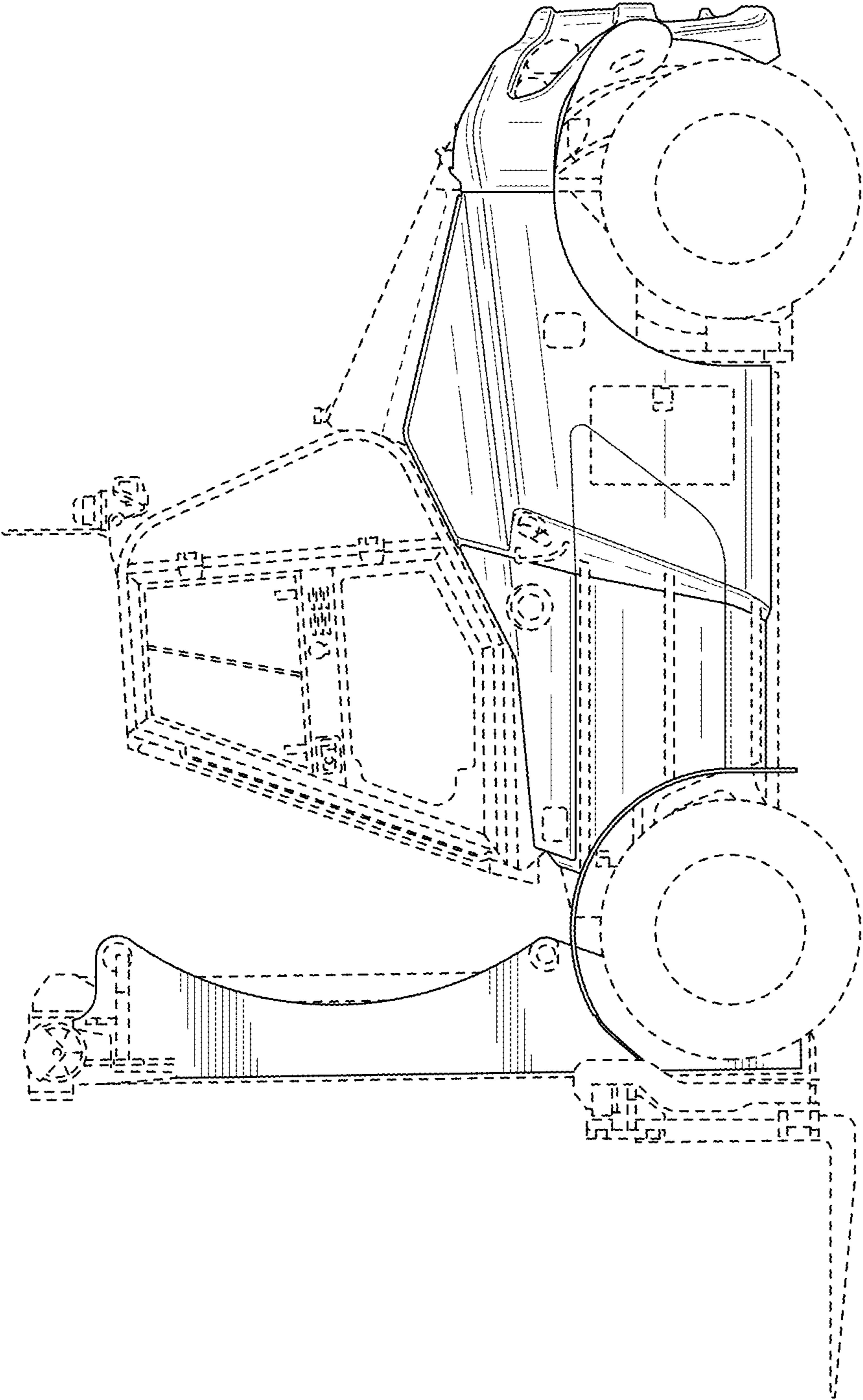

FIG. 4

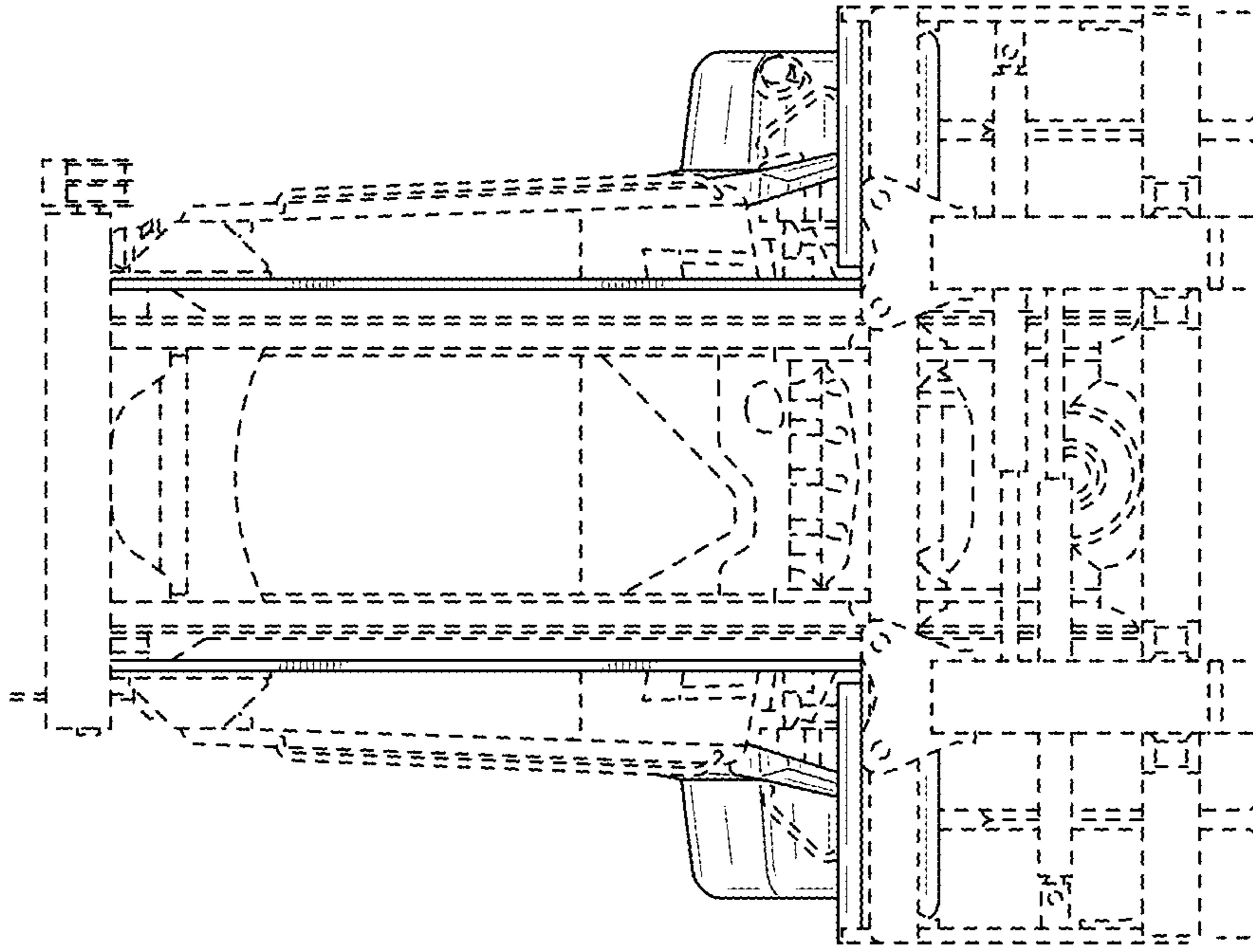

FIG. 5

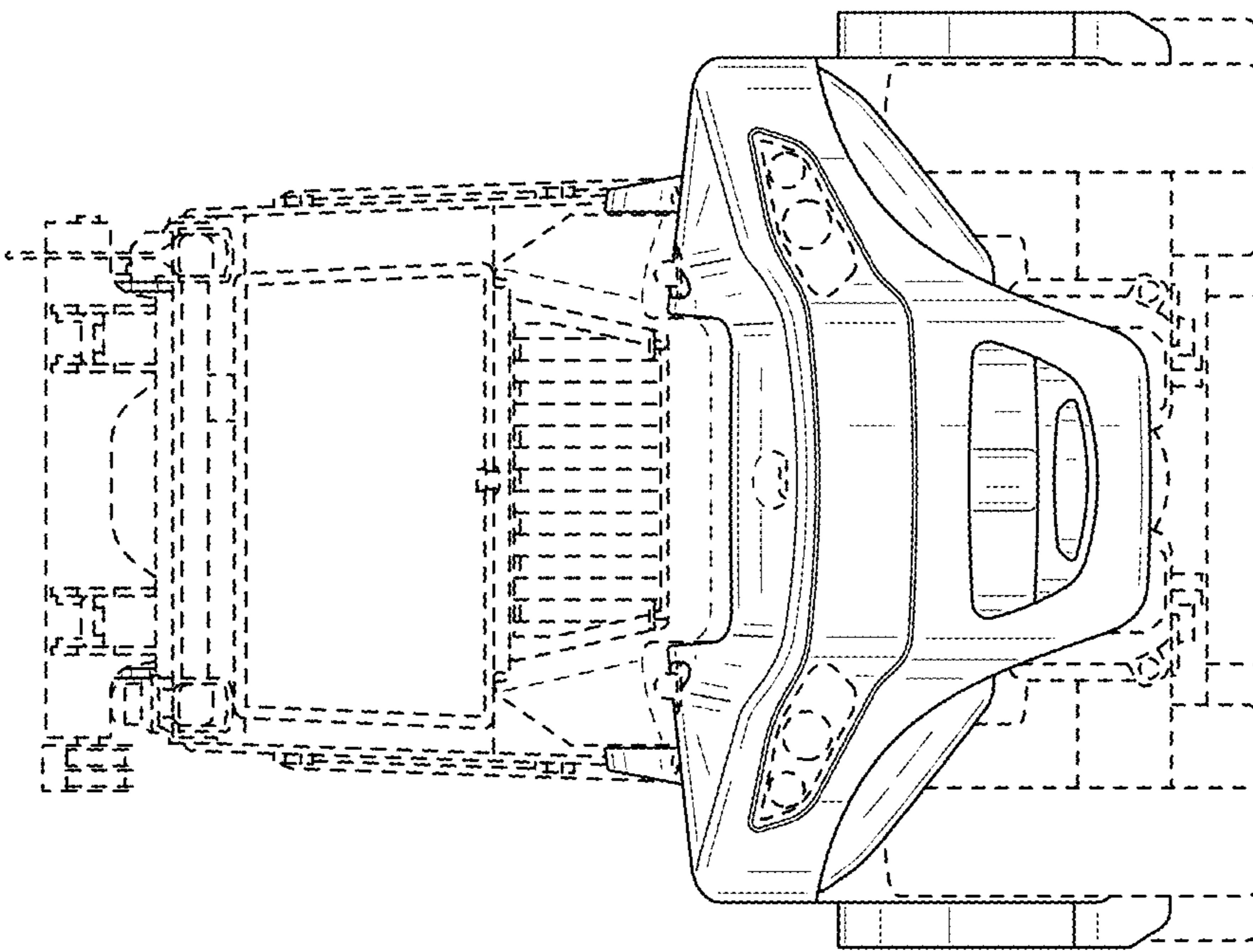

FIG. 6

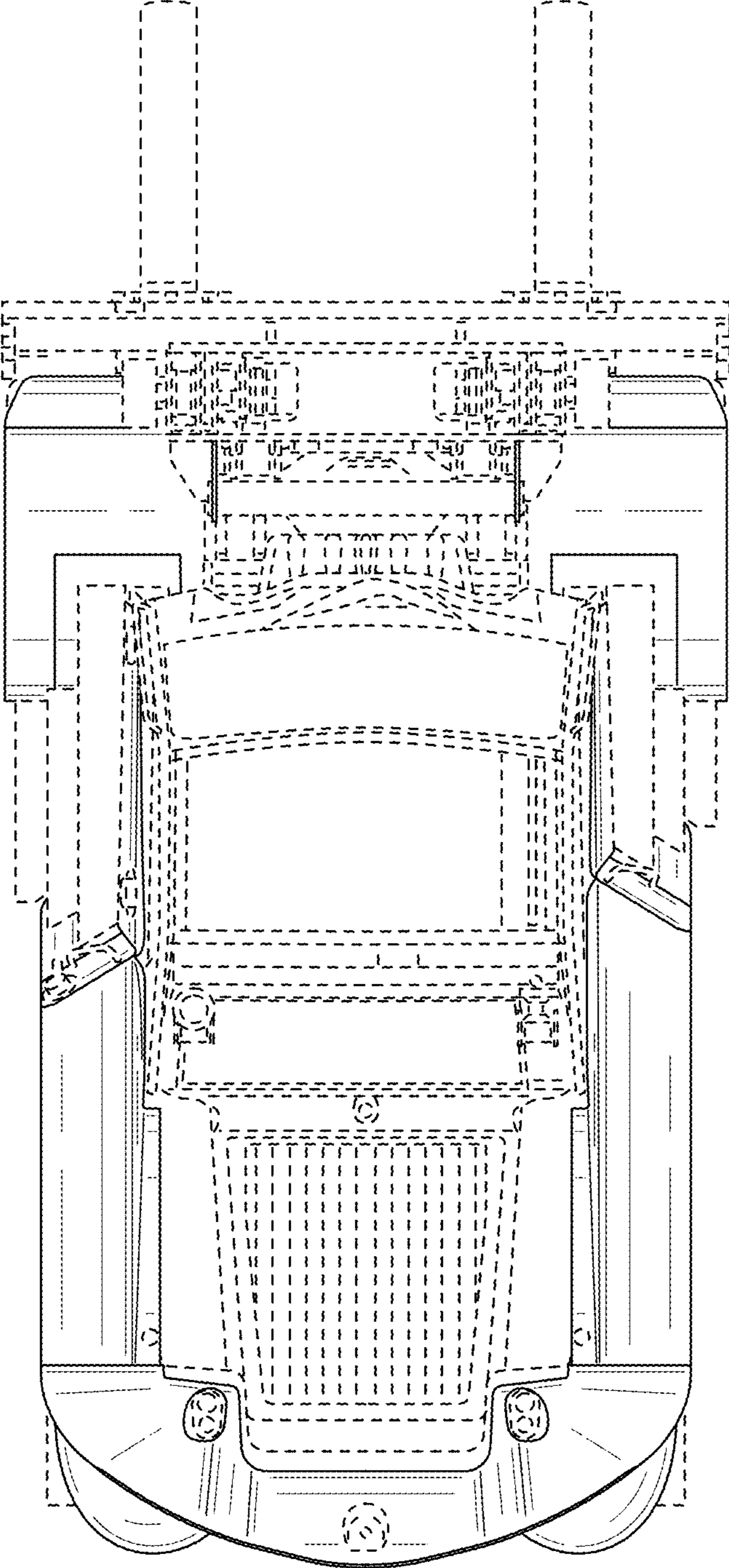

FIG. 7