



US00D778330S

(12) **United States Design Patent** (10) **Patent No.:** **US D778,330 S**
Fang et al. (45) **Date of Patent:** **** Feb. 7, 2017**

(54) **DOUBLE-SIDED TANGENTIAL CUTTING INSERT**

- (71) Applicant: **Kennametal Inc.**, Latrobe, PA (US)
- (72) Inventors: **Xiangdong Daniel Fang**, Brentwood, TN (US); **Jean-Luc Dufour**, Franklin, TN (US); **Lance Brunetto**, Greensburg, PA (US); **Kent Mizgalski**, Stahlstown, PA (US); **David Wills**, Greensburg, PA (US); **David Cope**, Mayfield Heights, OH (US)
- (73) Assignee: **KENNAMETAL INC.**, Latrobe, PA (US)

- (**) Term: **15 Years**
- (21) Appl. No.: **29/541,311**
- (22) Filed: **Oct. 2, 2015**

Related U.S. Application Data

- (63) Continuation-in-part of application No. 14/801,181, filed on Jul. 16, 2015.
- (51) **LOC (10) Cl.** **15-09**
- (52) **U.S. Cl.**
USPC **D15/139**
- (58) **Field of Classification Search**
USPC D8/20, 70; D15/126, 131, 138, 139, 140
CPC B23C 2200/0494; B23C 2200/086;
B23C 2200/128; B23C 2200/362; B23C 5/15; B23C 5/06; B23C 5/207; B23C 2200/367; B23C 2200/0422; B23C 27/007; B23C 27/143; B23C 2200/321; B23C 2200/087; B23C 27/145; B23C 27/1622; B23C 2200/048; B23C 2200/204; B23C 2200/085; B23C 2200/0423; B23C 5/205; B23C 2200/125; B23C 2200/0416; B23C 2200/0477

See application file for complete search history.

(56) **References Cited**

U.S. PATENT DOCUMENTS

4,632,607 A	12/1986	Pantzar	
D341,604 S *	11/1993	Hessman	D15/139
D347,642 S *	6/1994	Lindberg	D15/139
D364,178 S *	11/1995	Hansson	D15/139
D379,360 S *	5/1997	Satran	D15/139

(Continued)

FOREIGN PATENT DOCUMENTS

CN	1913998 A	2/2007
CN	201931144 U	8/2011

(Continued)

Primary Examiner — Patricia Palasik

(74) *Attorney, Agent, or Firm* — Matthew S. Bedsole

(57) **CLAIM**

The ornamental design for a double-sided tangential cutting insert, as shown and described.

DESCRIPTION

FIG. 1 is an isometric view of the double-sided tangential cutting insert;
 FIG. 2 is a front elevational view of the double-sided tangential cutting insert of FIG. 1 ;
 FIG. 3 is a rear elevational view of the double-sided tangential cutting insert of FIG. 1 ;
 FIG. 4 is a right side elevational view of the double-sided tangential cutting insert of FIG. 1 ;
 FIG. 5 is a left side elevational view of the double-sided tangential cutting insert of FIG. 1 ;
 FIG. 6 is a top plan view of the double-sided tangential cutting insert of FIG. 1 ; and,
 FIG. 7 is a bottom plan view of the double-sided tangential cutting insert of FIG. 1.

1 Claim, 6 Drawing Sheets

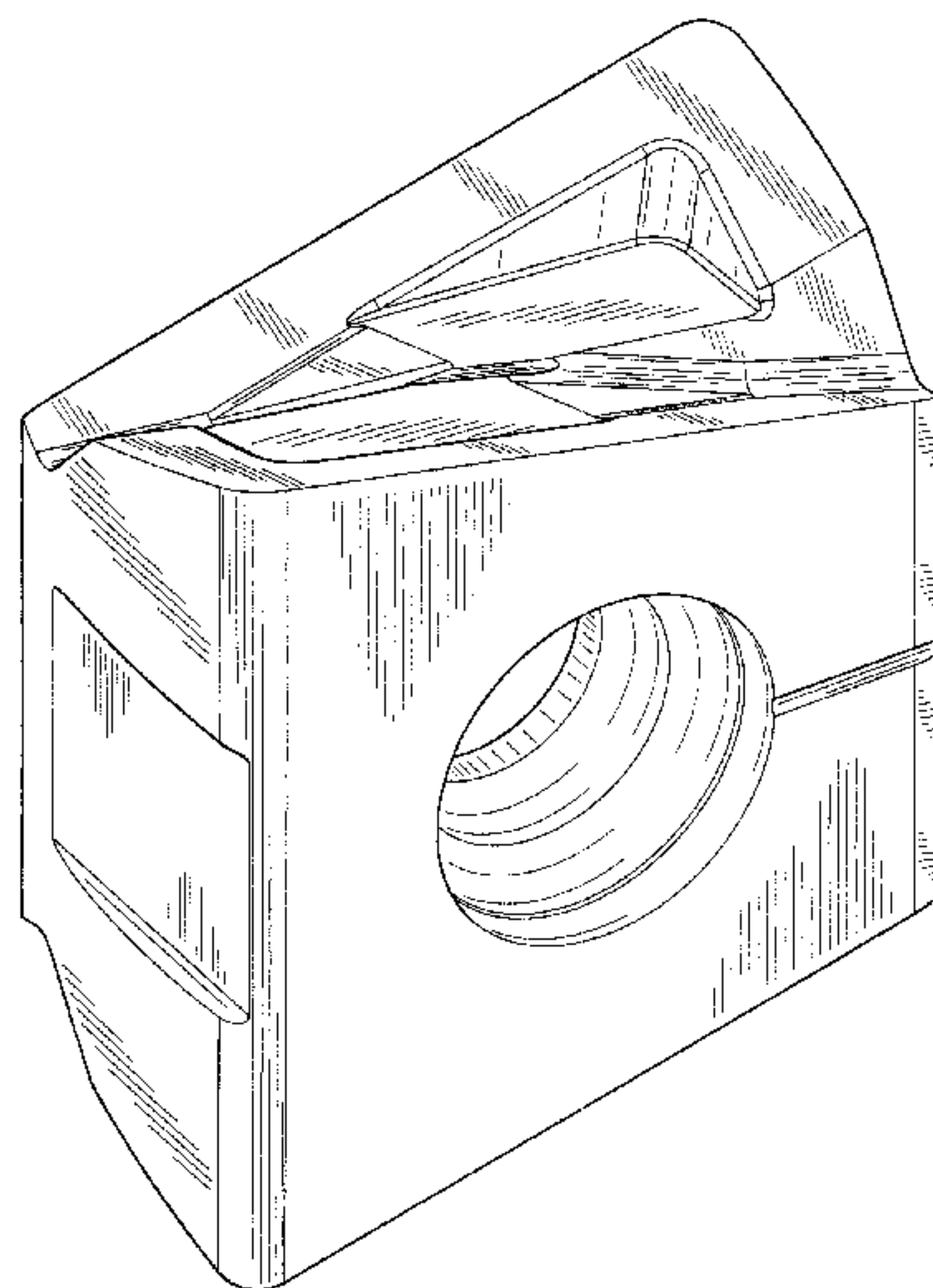

(56)

References Cited

U.S. PATENT DOCUMENTS

D404,406 S * 1/1999 Satran D15/139
 5,863,156 A 1/1999 Satran et al.
 6,074,137 A 6/2000 Betman et al.
 6,146,063 A 11/2000 Ramold et al.
 6,227,772 B1 5/2001 Heinloth et al.
 6,238,146 B1 5/2001 Satran et al.
 6,536,996 B2 3/2003 Satran et al.
 D485,852 S * 1/2004 Arvidsson D15/139
 6,682,274 B2 1/2004 Votsch et al.
 D486,505 S * 2/2004 Arvidsson D15/139
 D487,281 S * 3/2004 Roman D15/139
 6,805,520 B2 10/2004 Gesell et al.
 6,872,034 B2 3/2005 Satran et al.
 6,929,429 B2 8/2005 Riviere
 6,966,729 B2 11/2005 Dehn et al.
 6,974,280 B2 12/2005 Satran et al.
 7,008,146 B2 3/2006 DeRoche et al.
 7,063,489 B2 6/2006 Satran
 7,073,987 B2 7/2006 Hecht
 7,094,007 B2 8/2006 Satran et al.
 7,097,393 B2 8/2006 Satran et al.
 7,104,735 B2 9/2006 Johnson et al.
 7,241,082 B2 7/2007 Smilovici et al.
 7,494,303 B2 2/2009 Koshinen
 7,549,825 B2 6/2009 Wermeister
 7,758,287 B2 7/2010 Alm et al.
 7,775,750 B2 8/2010 Satran et al.
 7,857,555 B2 12/2010 Wermeister
 7,909,544 B2 3/2011 Jansson
 7,922,427 B2 4/2011 Spitzenberger et al.
 D637,214 S * 5/2011 Saito D15/139
 D638,041 S * 5/2011 Saito D15/139
 7,976,250 B2 7/2011 Fang et al.
 8,100,610 B2 1/2012 Kirchberger
 8,172,487 B2 5/2012 Ballas
 8,202,026 B2 6/2012 Satran et al.
 8,277,153 B2 10/2012 Kovac et al.
 8,282,320 B2 10/2012 Hartlohner et al.
 8,366,359 B2 2/2013 Heinloth et al.
 8,388,275 B2 3/2013 Hecht
 8,430,606 B2 4/2013 Zettler
 8,434,974 B2 5/2013 Spitzenberger
 8,449,230 B2 5/2013 Nguyen et al.
 8,454,278 B2 6/2013 Hartlohner et al.
 8,491,234 B2 7/2013 Fang et al.
 D688,716 S * 8/2013 Lampe D15/139
 8,511,942 B2 8/2013 Kretschmann et al.
 8,529,167 B2 9/2013 Shaheen
 8,550,754 B2 10/2013 Hecht
 8,556,546 B2 10/2013 Smilovici et al.
 8,568,065 B2 10/2013 Neiman et al.
 8,573,905 B2 11/2013 Hecht
 8,641,331 B2 2/2014 Zastrozynski et al.
 8,678,718 B2 3/2014 Hecht
 8,696,255 B2 4/2014 Hecht
 8,702,353 B2 4/2014 Chen et al.
 8,753,045 B2 6/2014 Hecht
 8,814,479 B2 8/2014 Kaufmann
 8,834,076 B2 9/2014 Gesell et al.
 8,876,440 B2 11/2014 Nam et al.
 8,882,405 B2 11/2014 Oprasic et al.
 8,931,979 B2 1/2015 Choi et al.
 8,967,920 B2 3/2015 Krishtul
 8,979,440 B2 3/2015 Ishi
 9,044,813 B2 6/2015 Choi et al.

D736,841 S * 8/2015 Jung D15/139
 D744,557 S * 12/2015 Koike D15/139
 D748,703 S 2/2016 Nam
 D750,941 S * 3/2016 Thiemer D7/649
 D752,664 S * 3/2016 Jung D15/139
 D755,267 S * 5/2016 Lee D15/139
 2009/0285646 A1 11/2009 Oprasic et al.
 2013/0121775 A1 5/2013 Dudzinsky et al.
 2013/0183108 A1 7/2013 Zettler
 2013/0195566 A1 8/2013 Bhagath
 2013/0322974 A1 12/2013 Scherbarth
 2014/0064864 A1 3/2014 Kaufmann et al.
 2014/0212229 A1 7/2014 Diepold
 2014/0341660 A1 11/2014 Cheon
 2014/0348599 A1 11/2014 Kovac et al.
 2014/0369773 A1 12/2014 Waggle et al.
 2015/0071717 A1 3/2015 Morrison et al.
 2015/0117968 A1 4/2015 Brunetto et al.
 2015/0117969 A1 4/2015 Brunetto et al.
 2015/0117970 A1 4/2015 Daub

FOREIGN PATENT DOCUMENTS

CN 103658797 A 3/2014
 CN 104174918 A 12/2014
 DE 102007011395 A1 9/2008
 EP 0958085 B1 4/2001
 EP 1097017 B1 9/2002
 EP 2805787 A1 8/2005
 EP 1480774 B1 6/2006
 EP 1572407 B1 1/2007
 EP 1610920 B1 2/2007
 EP 2332681 A2 2/2007
 EP 1238734 B1 6/2007
 EP 1677934 B1 4/2008
 EP 2214857 B1 11/2008
 EP 1509354 B1 11/2009
 EP 2119520 A1 11/2009
 EP 1565285 B1 8/2010
 EP 1991382 B1 3/2011
 EP 2144724 B1 5/2011
 EP 2368658 A1 9/2011
 EP 1846182 B1 8/2012
 EP 2229255 B1 3/2013
 EP 1711296 B1 5/2013
 EP 2759365 A2 1/2014
 EP 2523773 B1 6/2014
 EP 2198997 B1 4/2015
 IL 160223 A1 2/2004
 IL 187721 B 11/2007
 IL 198726 A1 5/2009
 IL 200063 B 7/2009
 JP 2007520360 T2 7/2007
 KR 100756291 B 9/2007
 KR 20090102423 A 9/2009
 KR 20130029199 A 3/2013
 KR 101308186 B 9/2013
 RU 108330 U 9/2011
 RU 133033 U 10/2013
 WO 2010126693 11/2010
 WO 2013023801 2/2013
 WO 2014006609 1/2014
 WO 2014033549 A2 3/2014
 WO 2014044419 3/2014
 WO 2014161658 10/2014
 WO 2015030421 3/2015

* cited by examiner

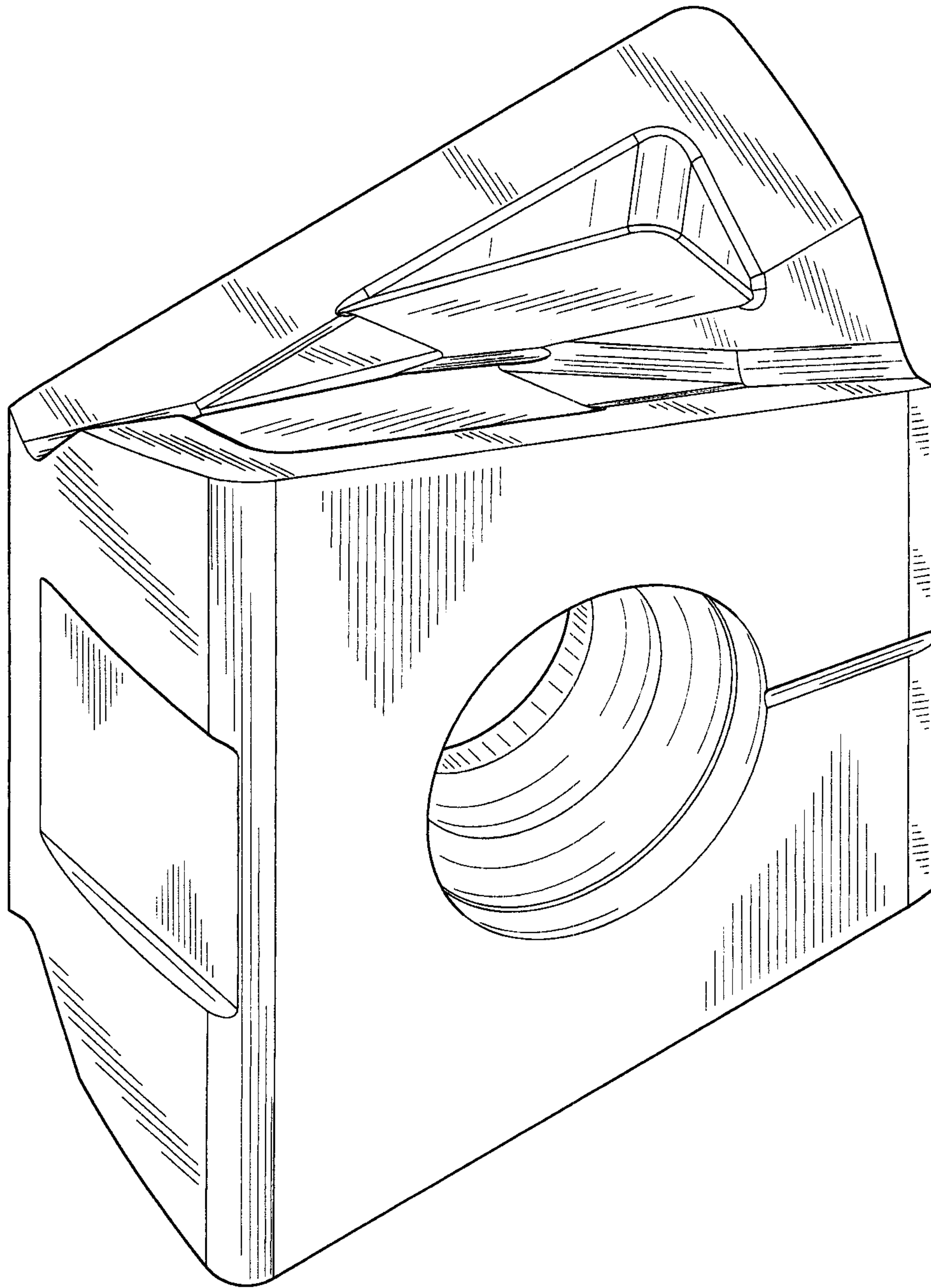

FIG. 1

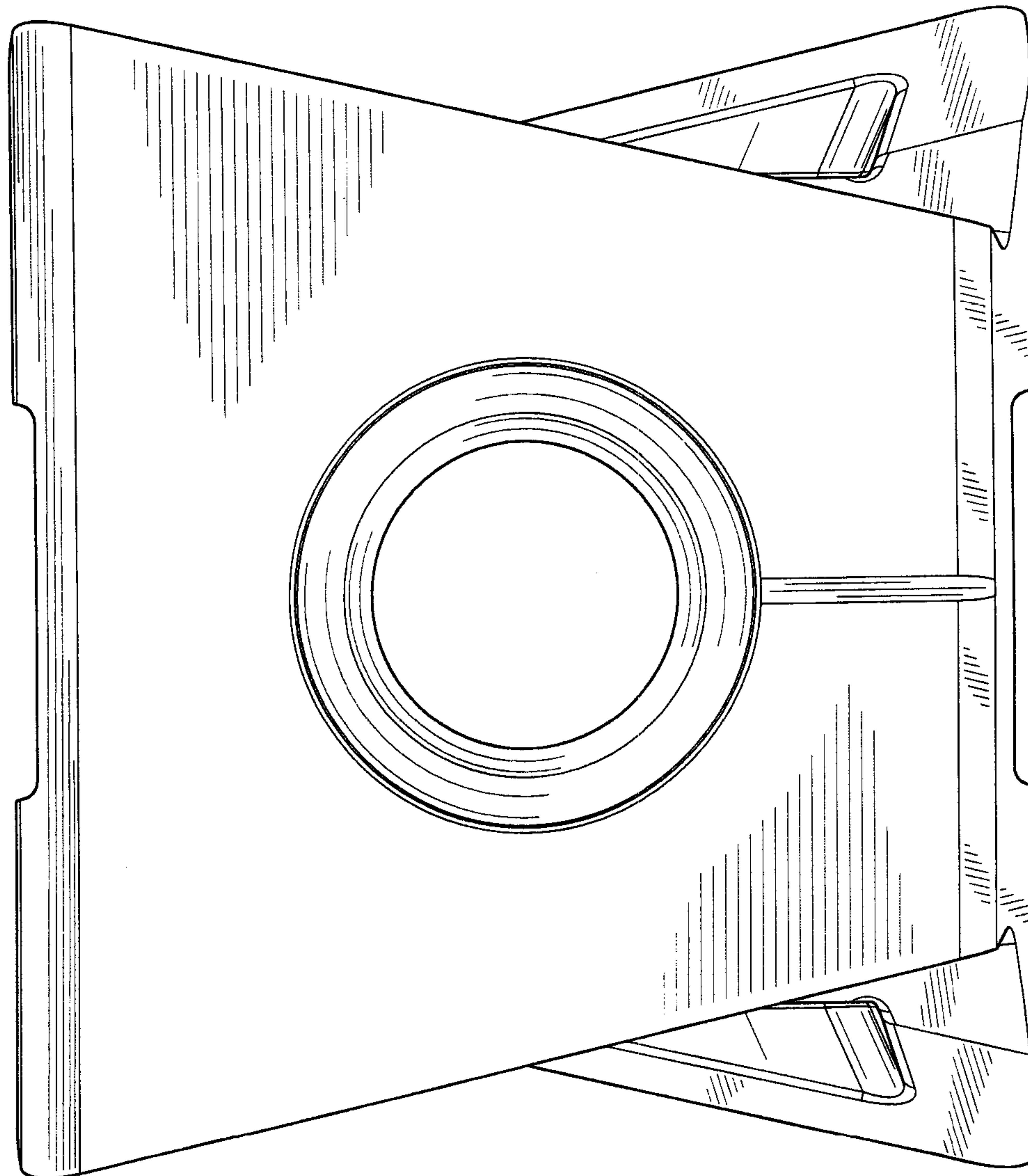

FIG. 2

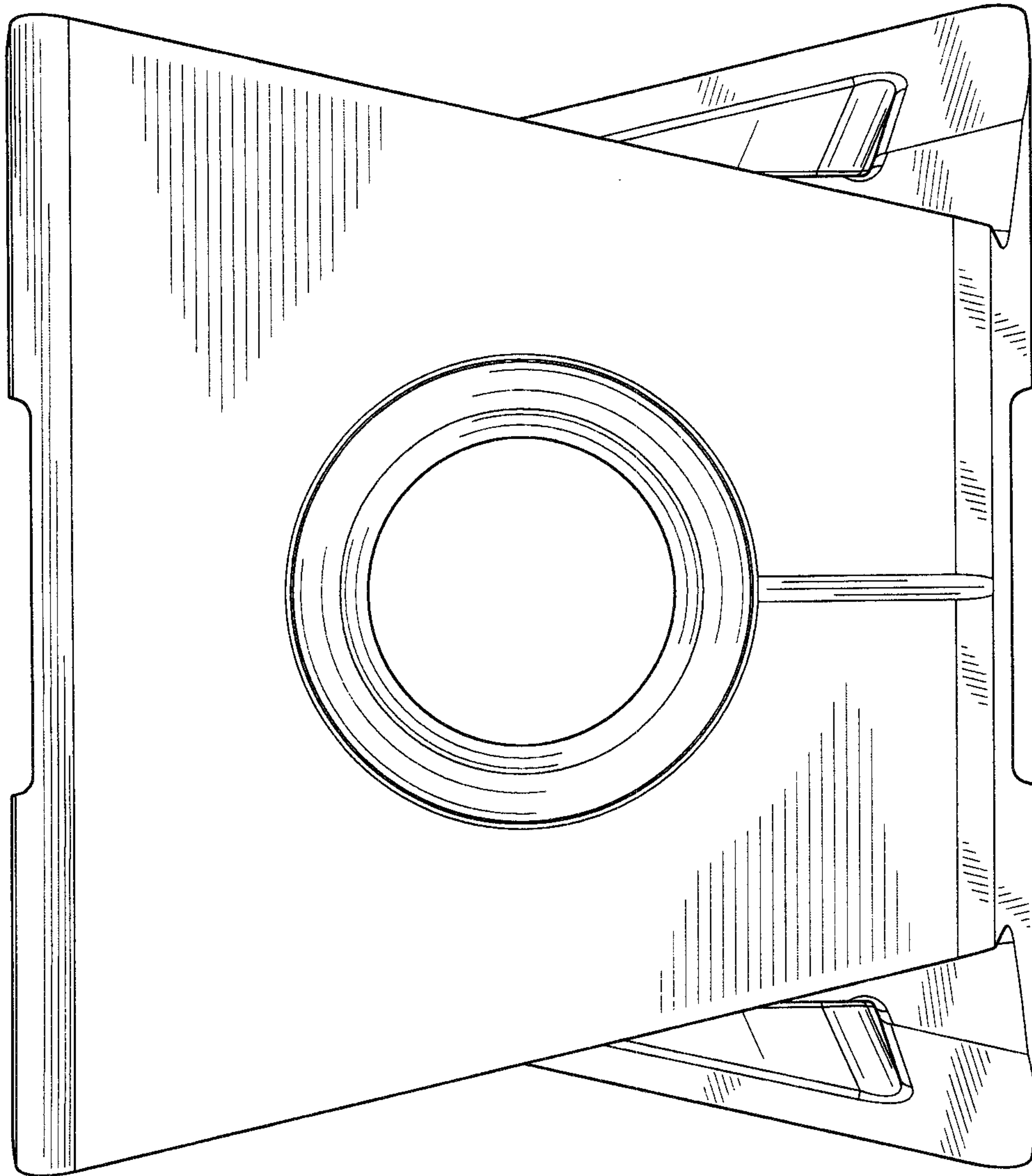

FIG. 3

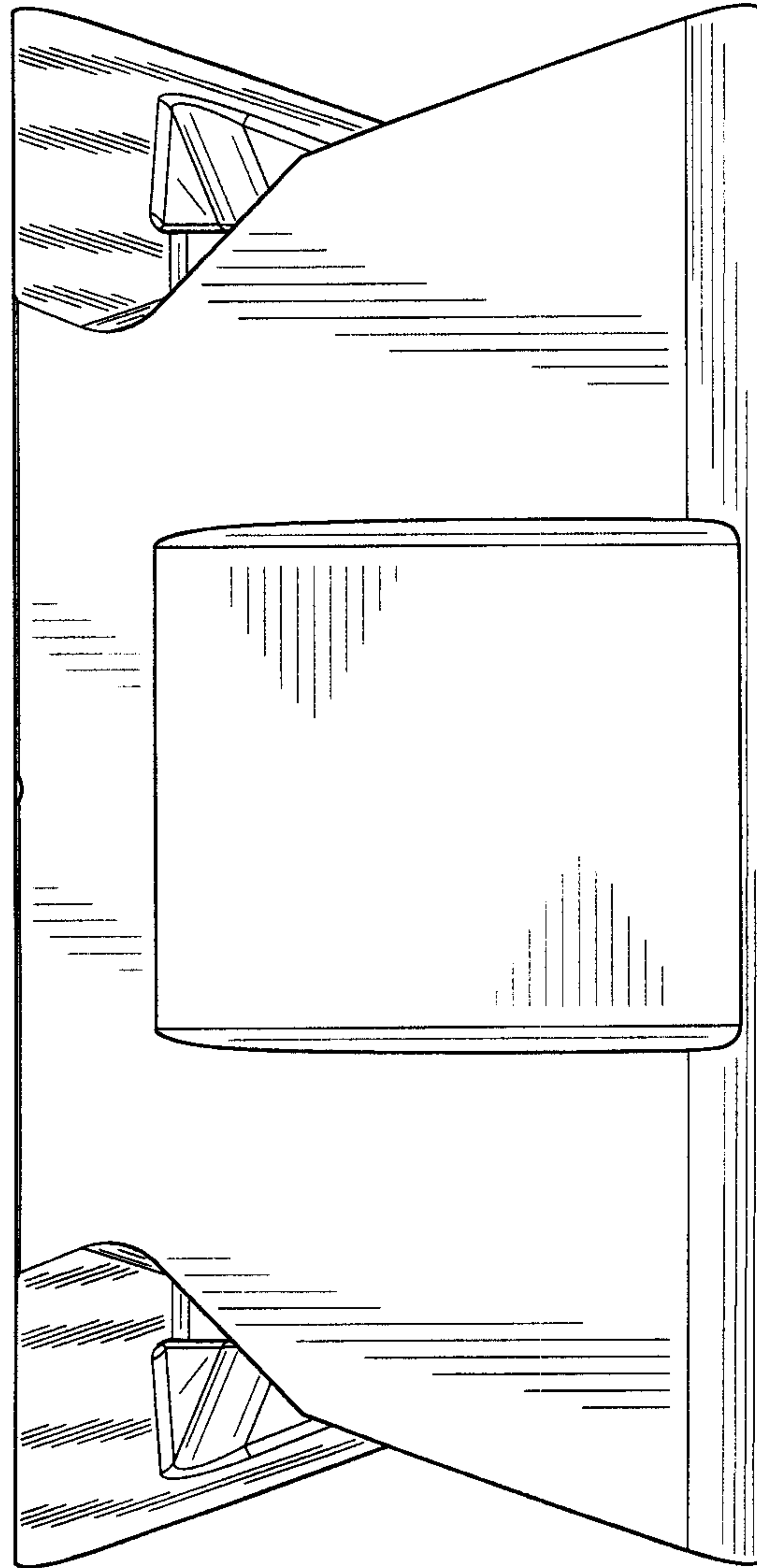

FIG. 4

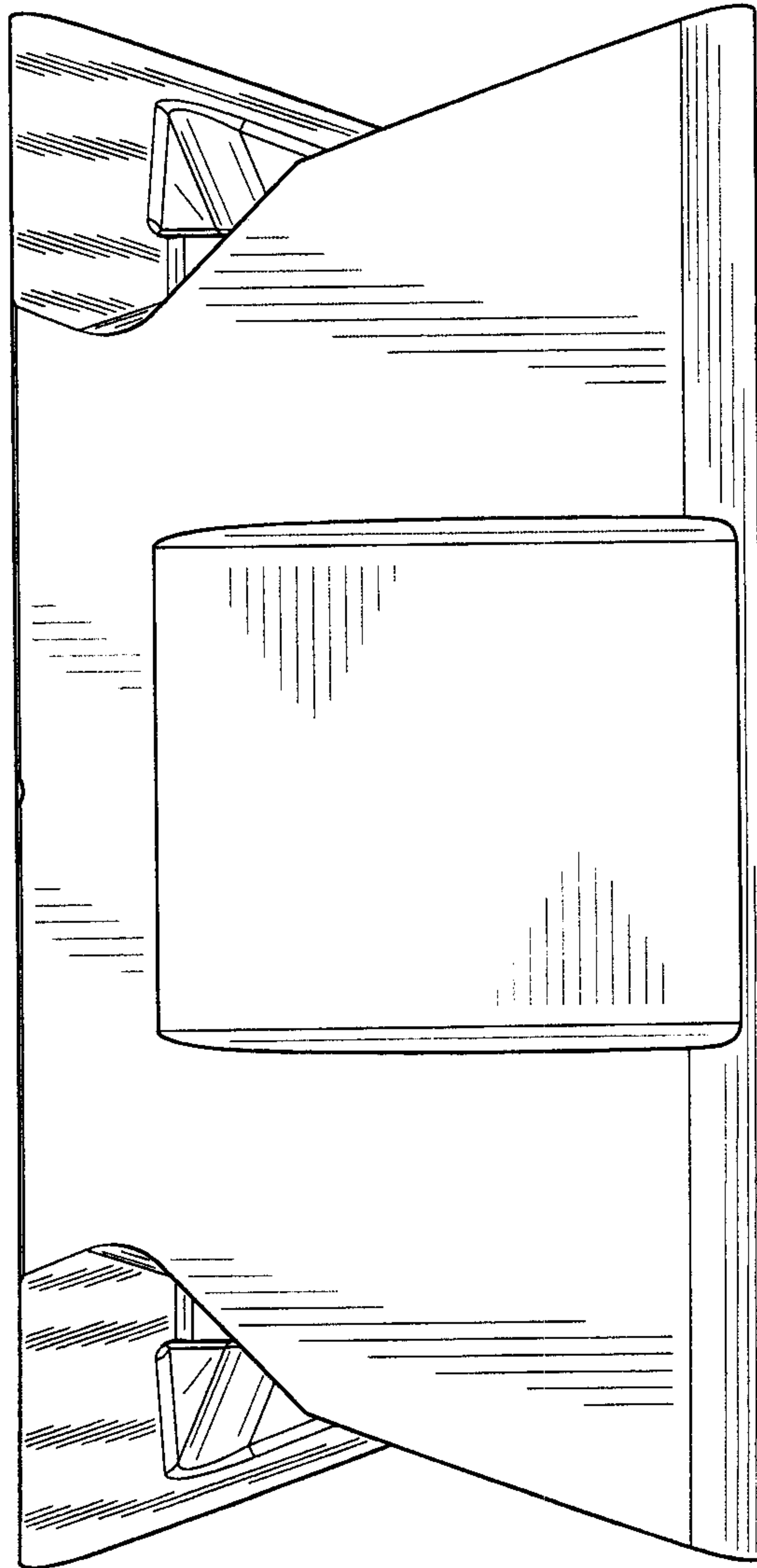

FIG. 5

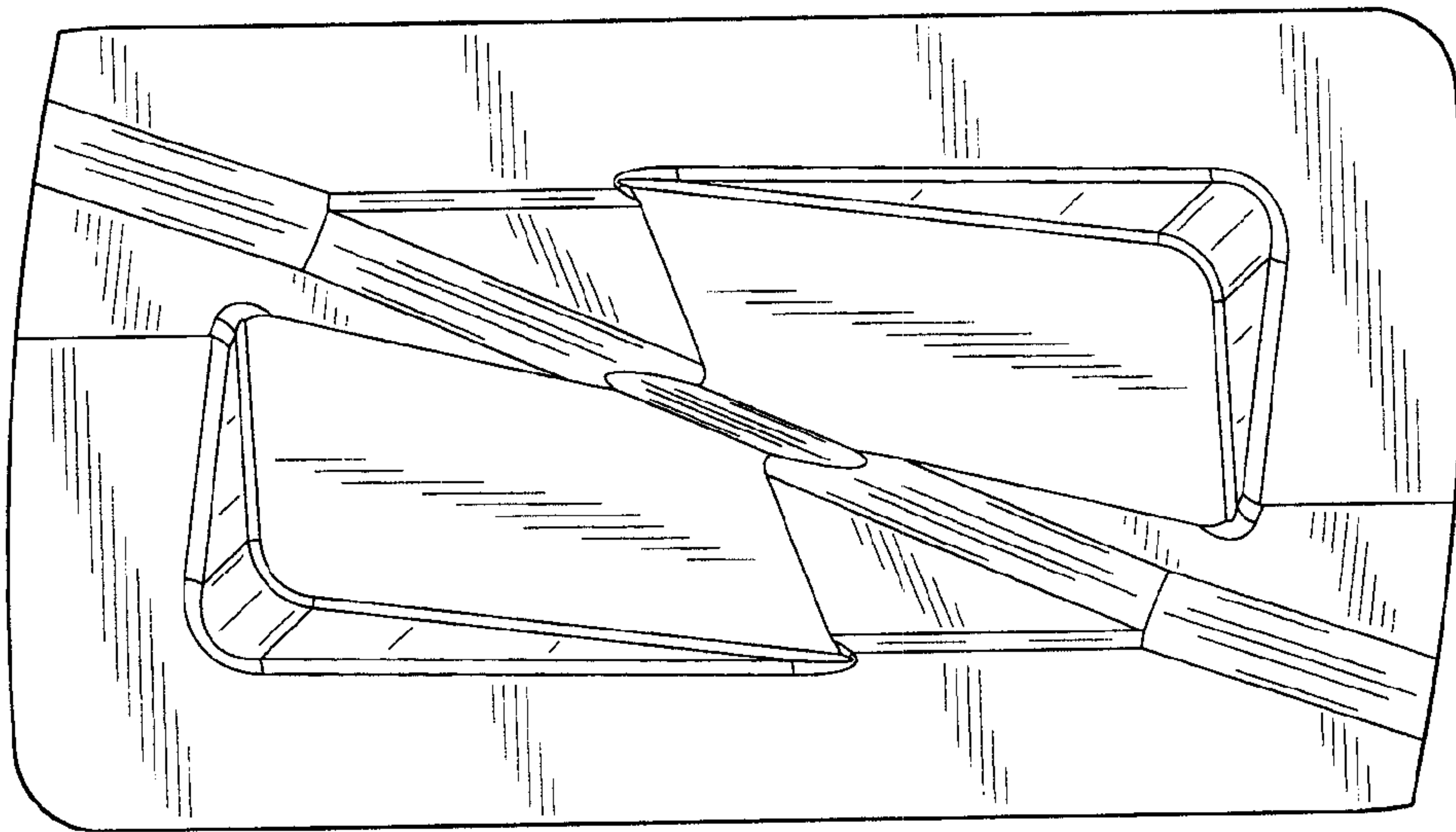

FIG. 6

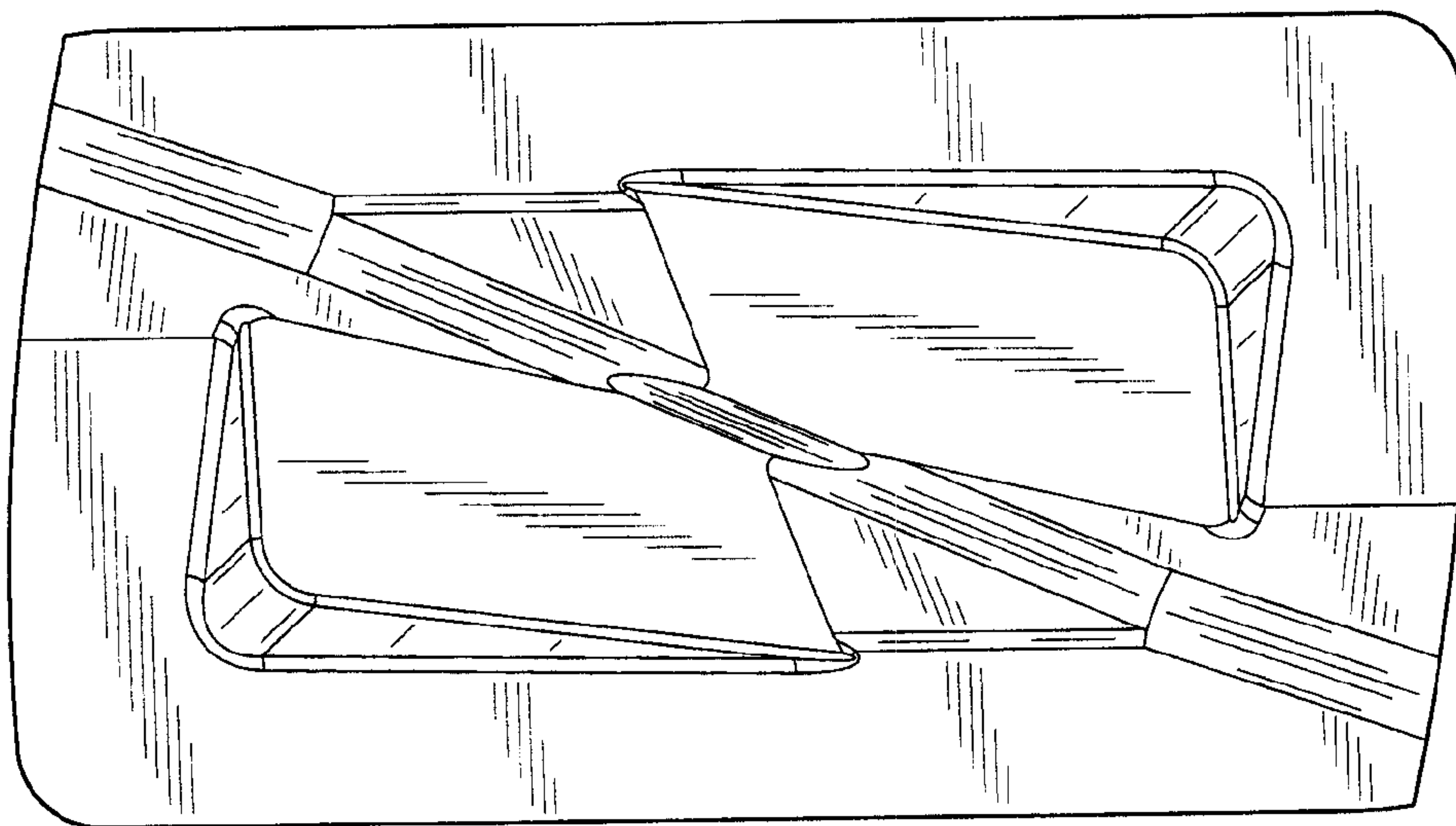

FIG. 7