



US00D778082S

(12) **United States Design Patent** (10) **Patent No.:** **US D778,082 S**
Abbott (45) **Date of Patent:** **** Feb. 7, 2017**

(54) **DOG WASTE BAG DISPENSER** 7,410,197 B2 * 8/2008 Edwards A01K 27/006
294/1.3
(71) Applicant: **Brian F. Abbott**, Fort Worth, TX (US) D654,739 S * 2/2012 Chin D3/215
D664,042 S * 7/2012 Kurpis D22/116
(72) Inventor: **Brian F. Abbott**, Fort Worth, TX (US) D707,785 S * 6/2014 Seecamp D22/116
D718,553 S * 12/2014 Gnanendran D6/518

(**) Term: **14 Years**

* cited by examiner

(21) Appl. No.: **29/517,619**

Primary Examiner — David Muller

(22) Filed: **Feb. 13, 2015**

Assistant Examiner — Nathan Johnston

(51) **LOC (10) Cl.** **20-02**

(74) *Attorney, Agent, or Firm* — Dobbin IP Law P.C.;

(52) **U.S. Cl.**

Geoffrey E. Dobbin

USPC **D6/518**

(57) **CLAIM**

(58) **Field of Classification Search**

The ornamental design for a dog waste bag dispenser, as shown and described.

USPC D6/515–523; 206/225, 233, 389, 391;
211/13.1; 222/173, 180; 221/26, 33, 282,
221/283, 61; 242/570, 590; 248/309.1,
248/309.2, 905; D22/116, 115

DESCRIPTION

CPC E01H 2001/128; E01H 1/1206; E01H
2001/1286; E01H 2001/124

See application file for complete search history.

FIG. 1 is a perspective view of the dog waste bag dispenser.
FIG. 2 is a front elevation thereof.
FIG. 3 is a right elevation thereof.
FIG. 4 is a rear elevation thereof.
FIG. 5 is a left elevation thereof.
FIG. 6 is a top plan view thereof.
FIG. 7 is a bottom plan view thereof.
FIG. 8 is an alternate perspective view thereof.
FIG. 9 is an alternate perspective view thereof; and,
FIG. 10 is an alternate perspective view thereof.

The broken line showing of parts of the drawings is included for the purpose of illustrating use and environment and forms no part of the claimed design.

(56) **References Cited**

U.S. PATENT DOCUMENTS

D309,339 S * 7/1990 Lutfy D22/116
5,135,134 A * 8/1992 Dancy B65H 35/002
221/155
D337,044 S * 7/1993 Pronchick D9/448
D452,894 S * 1/2002 Benini D22/116
D464,179 S * 10/2002 Petersen D30/153
D518,727 S * 4/2006 Haley D22/116
D521,781 S * 5/2006 Edwards D6/518
D568,653 S * 5/2008 Edwards D6/515

1 Claim, 9 Drawing Sheets

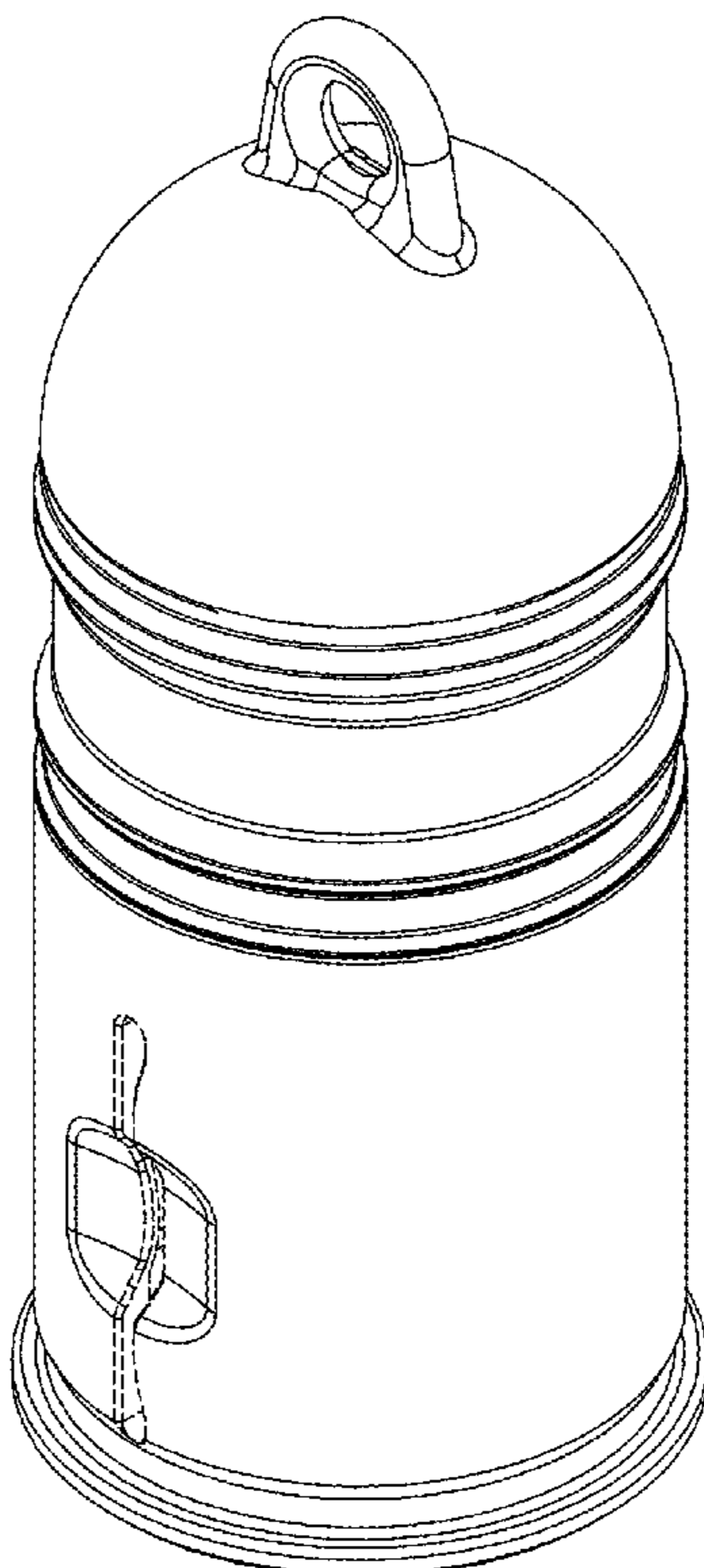

FIG. 1

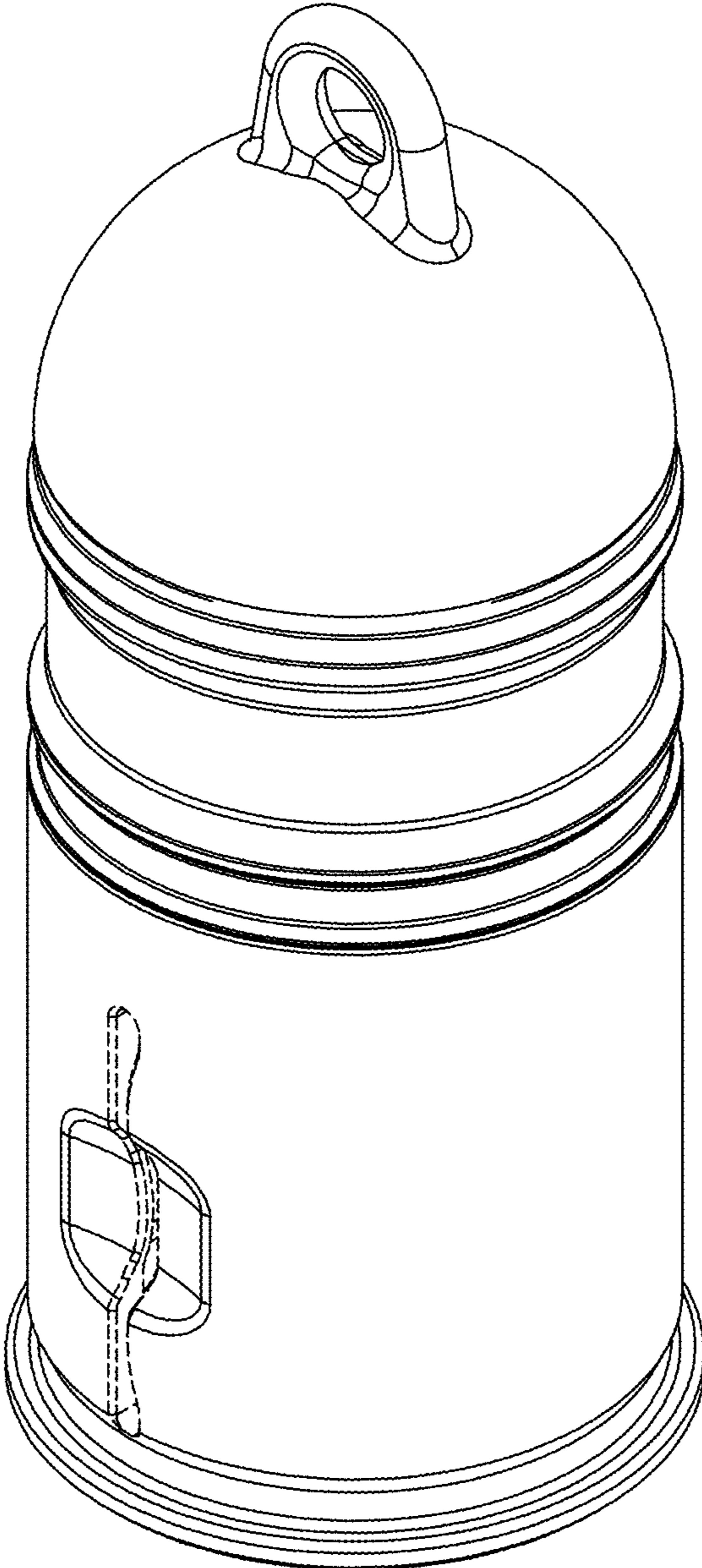

FIG. 2

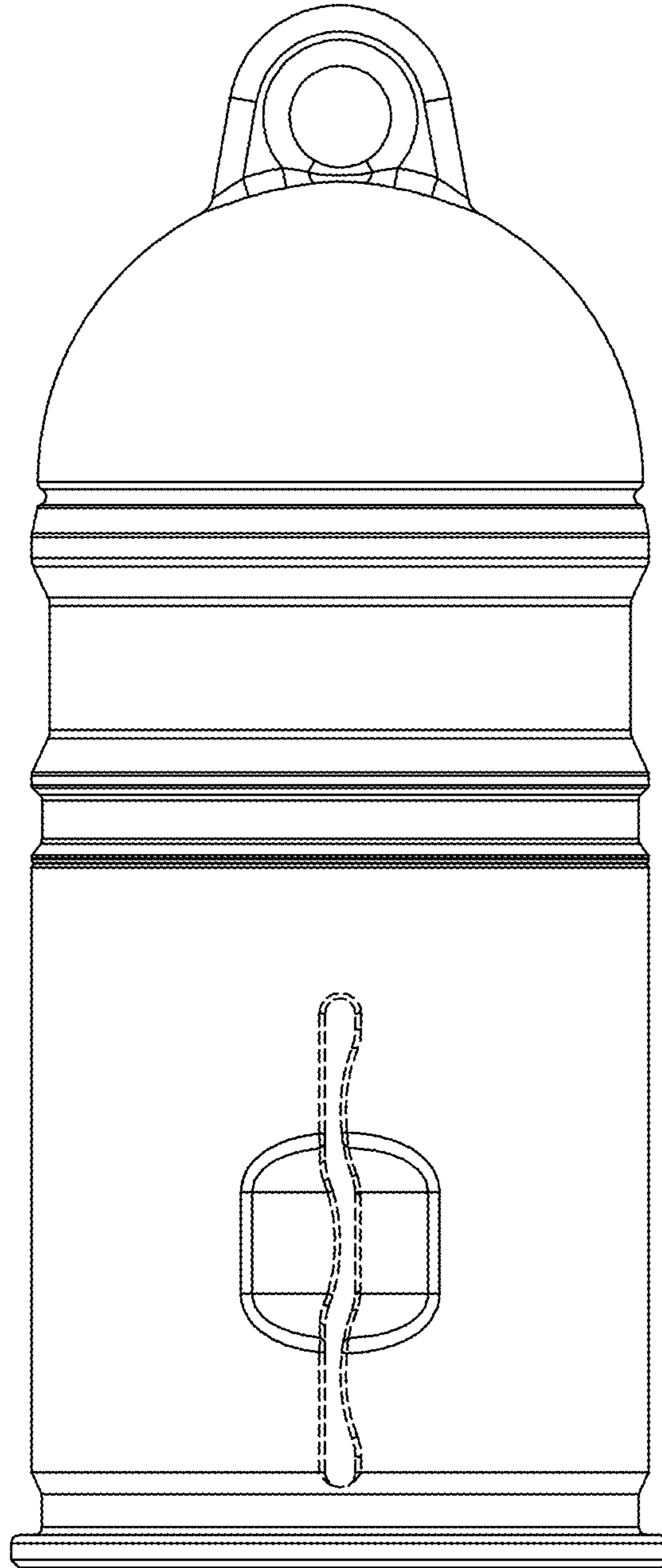

FIG. 3

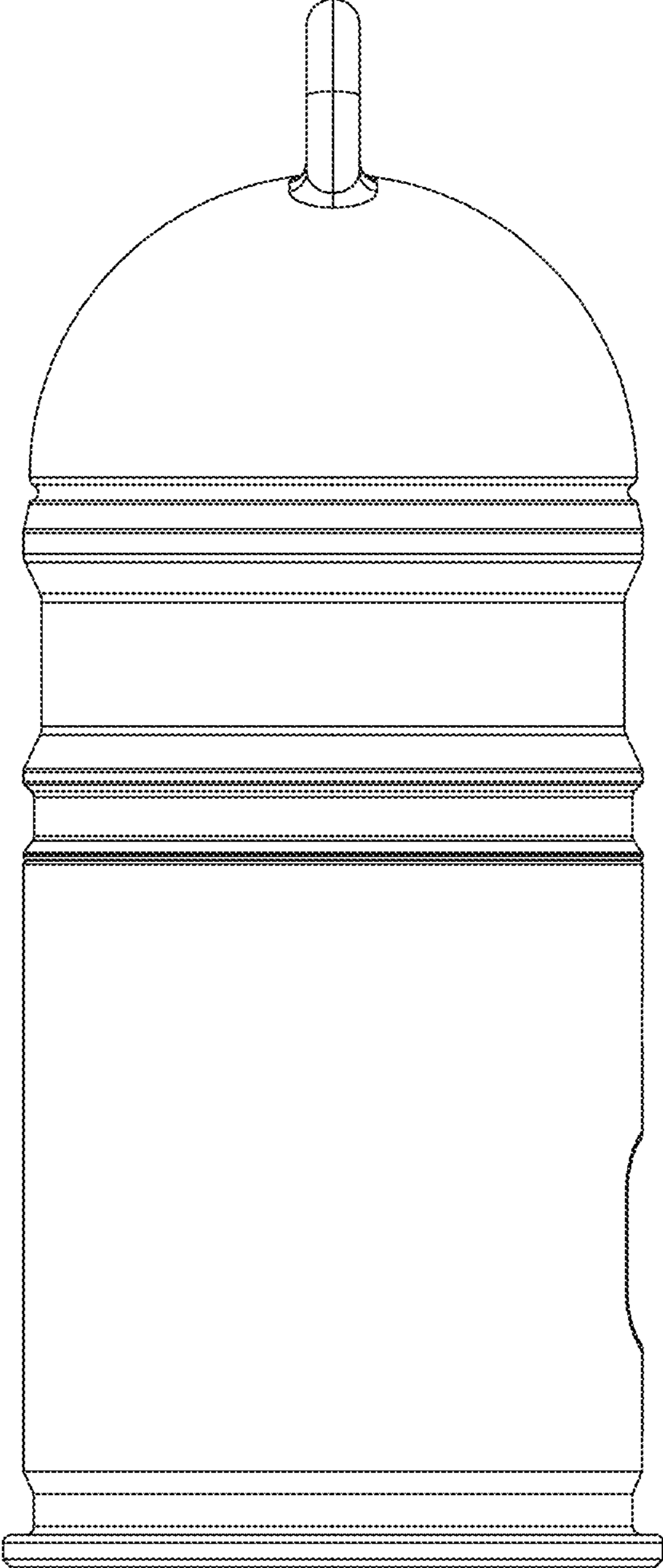

FIG. 4

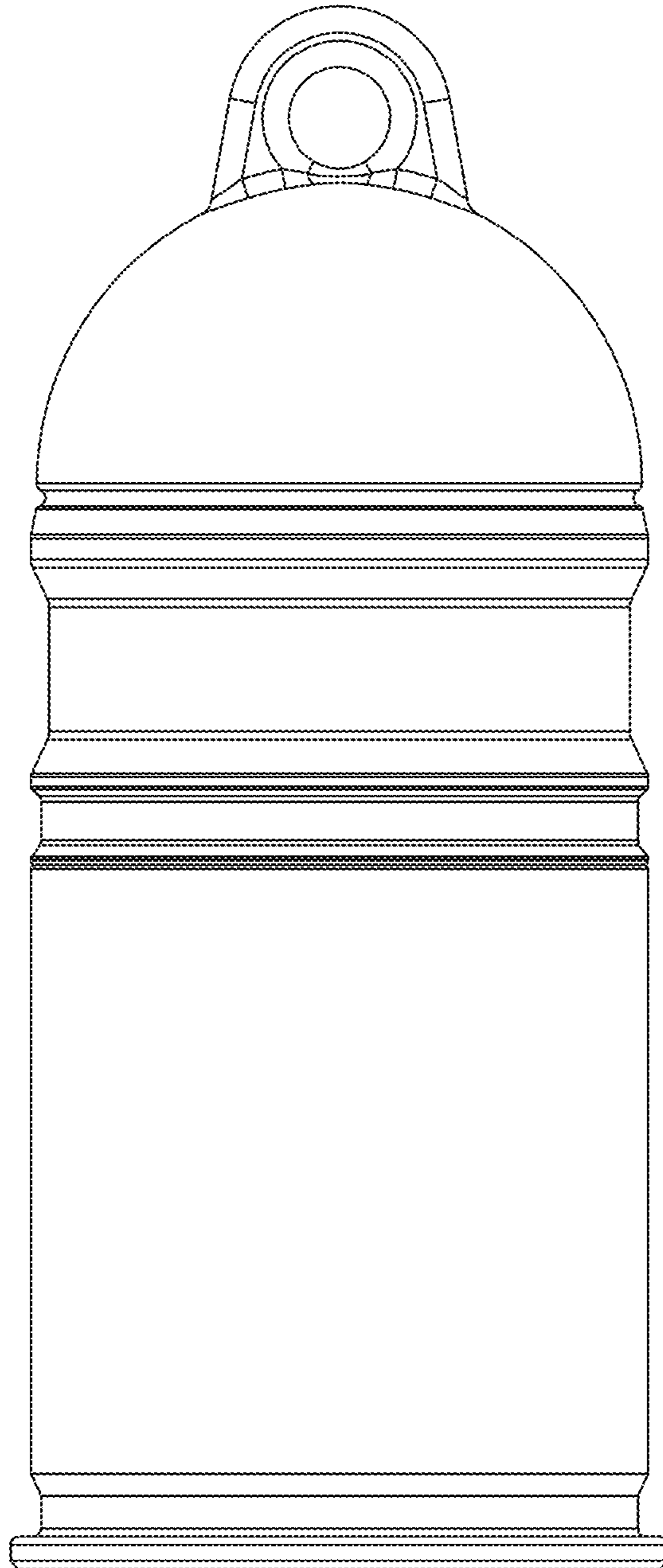

FIG. 5

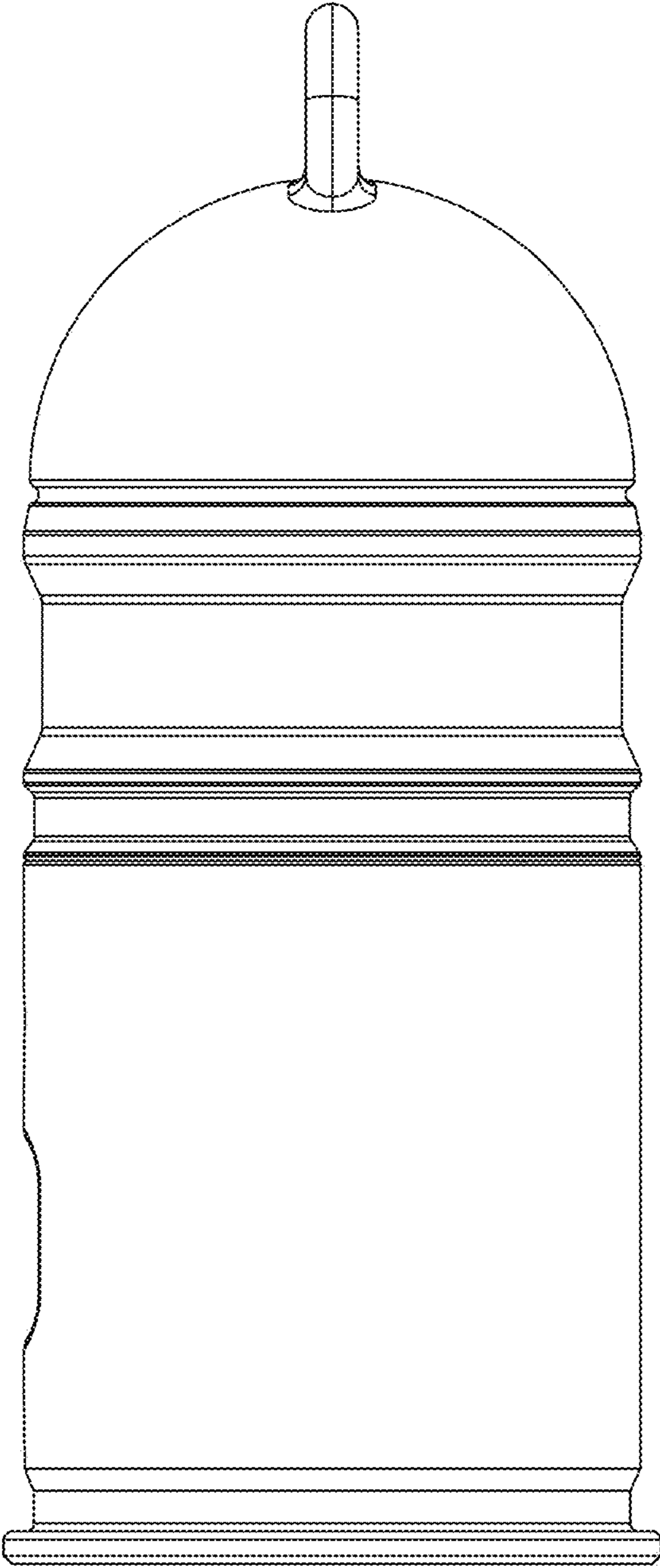

FIG. 6

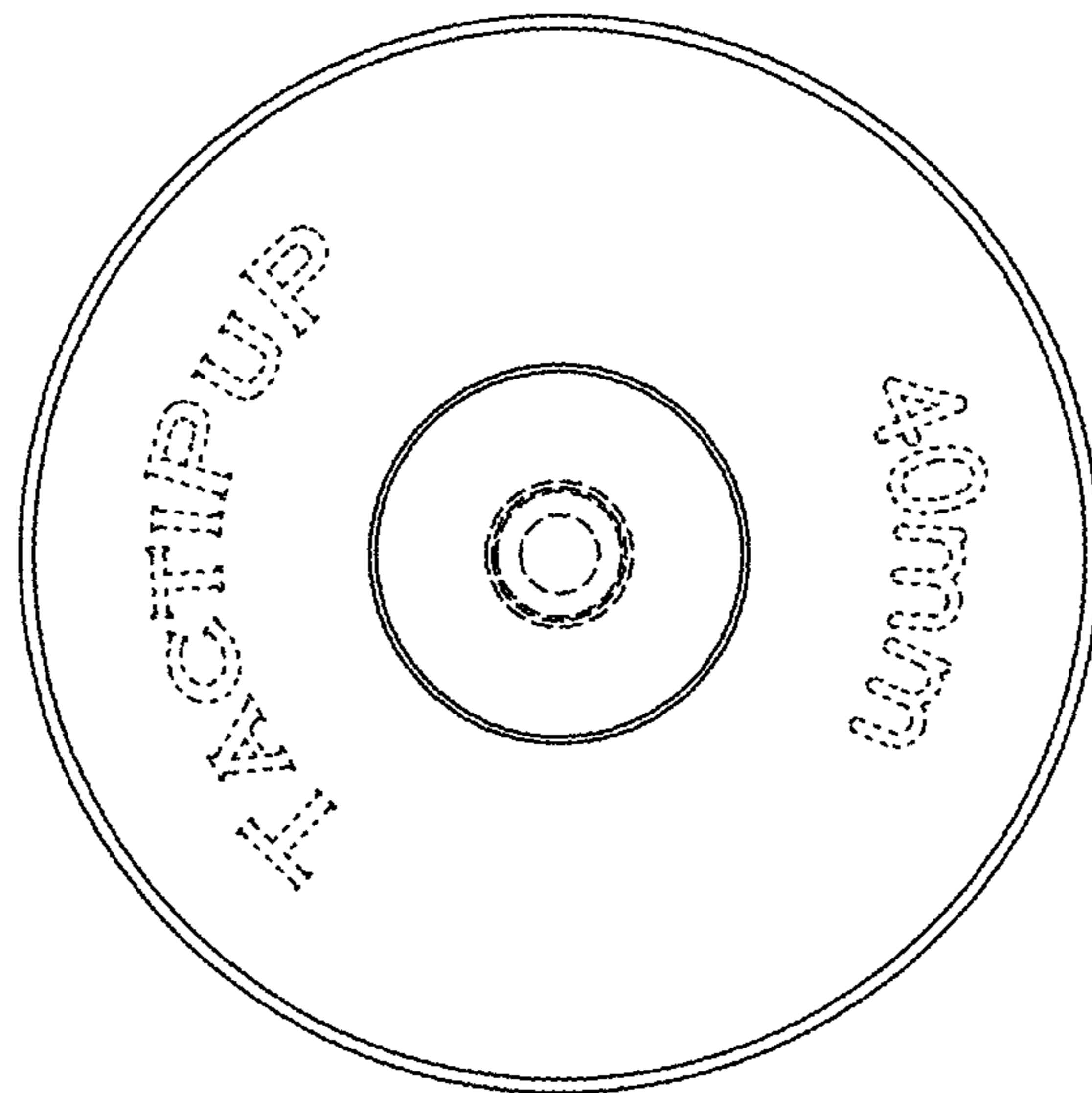
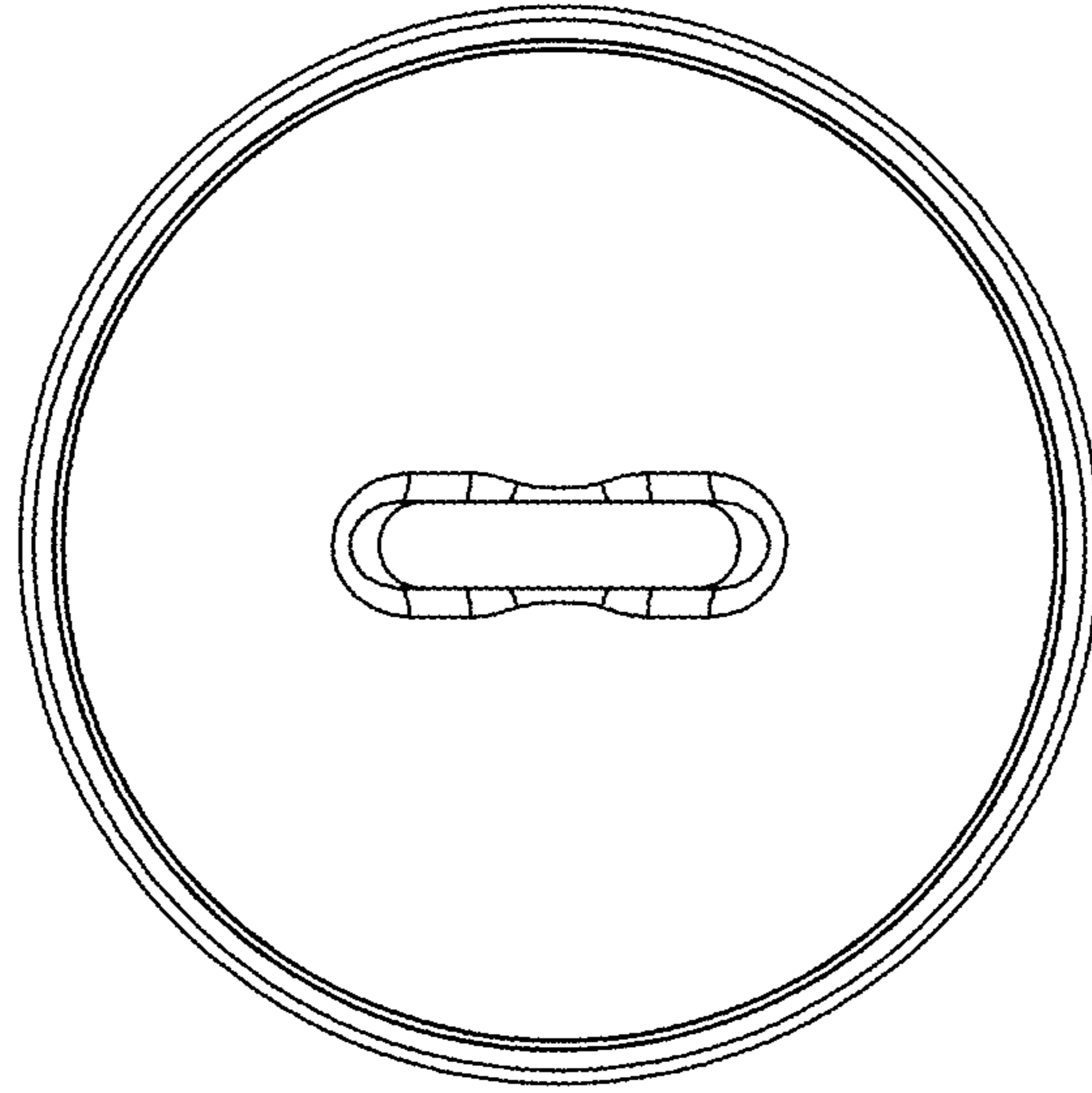

FIG. 7

FIG. 8

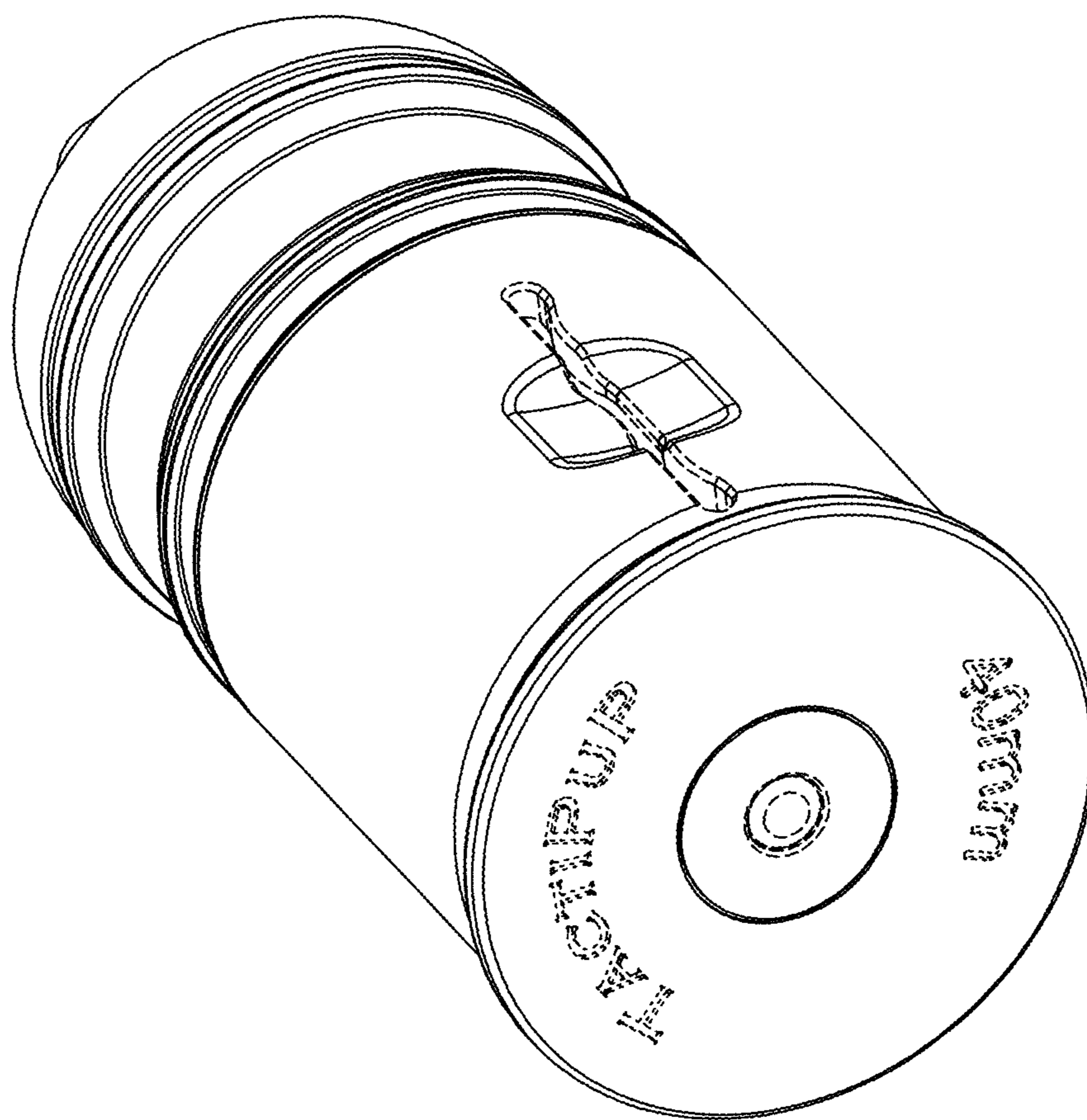

FIG. 9

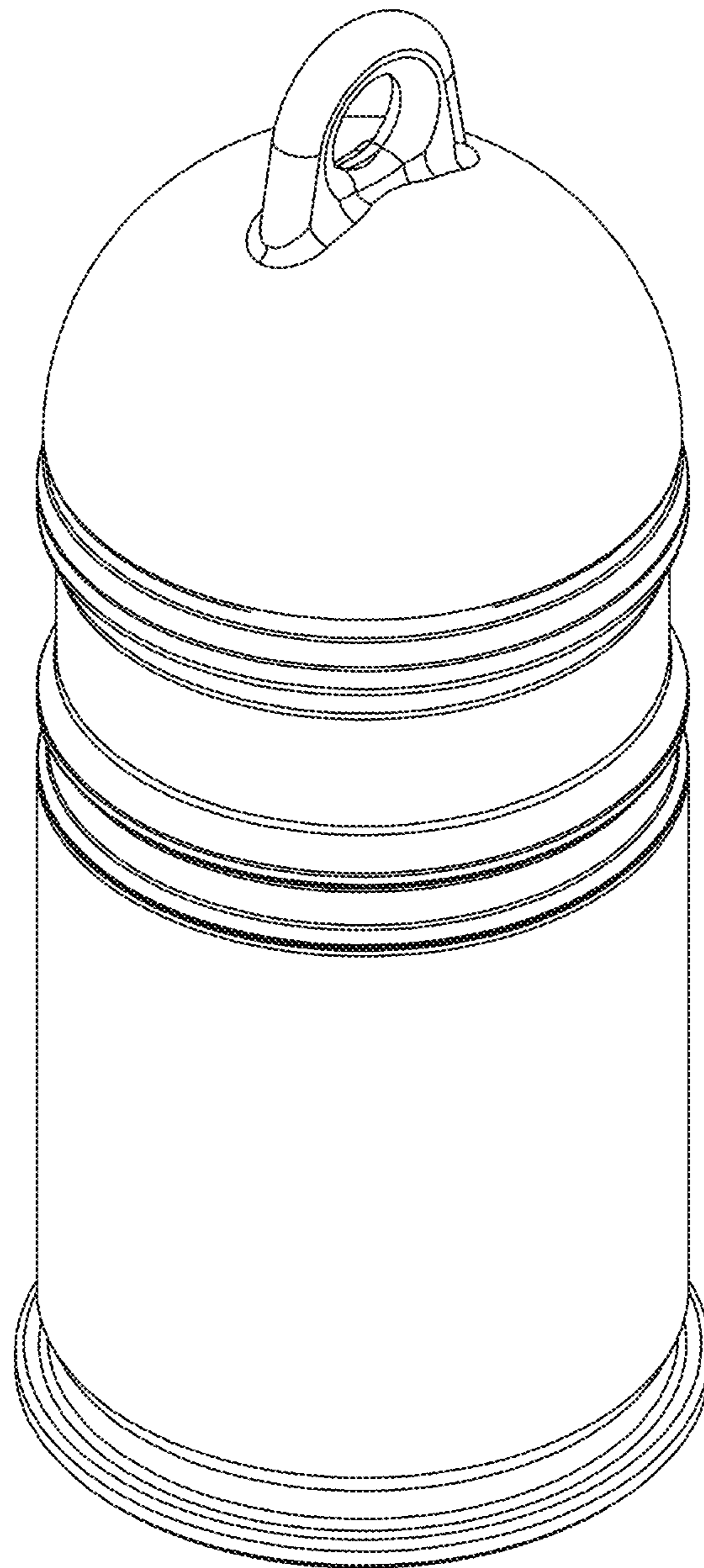

FIG. 10

