



US00D777954S

(12) **United States Design Patent**
Salami, Jr.

(10) **Patent No.:** **US D777,954 S**
(45) **Date of Patent:** **** Jan. 31, 2017**

- (54) **VEHICLE LIGHT APPARATUS**
- (71) Applicant: **Joseph D. Salami, Jr.**, Westwood, MA (US)
- (72) Inventor: **Joseph D. Salami, Jr.**, Westwood, MA (US)
- (73) Assignee: **SALPRO, Corp.**, Westwood, MA (US)
- (**) Term: **15 Years**
- (21) Appl. No.: **29/534,506**
- (22) Filed: **Jul. 29, 2015**
- (51) **LOC (10) Cl.** **26-06**
- (52) **U.S. Cl.**
USPC **D26/28**
- (58) **Field of Classification Search**
USPC D26/28-36; 362/459-468, 475-478, 362/485-487
CPC F21S 48/00; F21S 48/10; F21S 48/115; F21S 48/225; F21S 48/1233; F21S 48/1266; F21S 48/1388; F21S 48/2268; F21V 21/04
See application file for complete search history.

6,379,028	B1	4/2002	Crouse et al.	
6,409,367	B1	6/2002	Pratt	
D469,196	S *	1/2003	Ohsawa	D26/35
D491,493	S *	6/2004	Stahel	D12/114
6,788,190	B2	9/2004	Bishop	
6,977,584	B2	12/2005	Milliken	
7,008,088	B2	3/2006	Pisciotti	
7,498,686	B2	3/2009	Capenos	
RE40,878	E	8/2009	Bishop	
8,552,852	B1	10/2013	Hertz et al.	
D709,227	S *	7/2014	Huang	D26/31
D712,075	S *	8/2014	Pavani	D26/28
D753,326	S *	4/2016	Wilson	D26/31
D757,316	S *	5/2016	Wymore	D26/31
D761,465	S *	7/2016	Sugesawa	D26/28

* cited by examiner

Primary Examiner — Angela J Lee
(74) *Attorney, Agent, or Firm* — Onello & Mello, LLP

(57) **CLAIM**

The ornamental design for a vehicle light apparatus, as shown and described.

DESCRIPTION

FIG. 1 is an isometric view of a vehicle light apparatus, in accordance with the present invention; FIG. 2 is a front view thereof; FIG. 3 is a rear view thereof; FIG. 4 is a top view thereof; FIG. 5 is a bottom view thereof; and FIG. 6 is a left side view thereof; and, FIG. 7 is a right side view thereof. In the drawings, broken lines illustrate environment and form no part of the claimed design.

1 Claim, 5 Drawing Sheets

(56) **References Cited**

U.S. PATENT DOCUMENTS

D267,818	S *	2/1983	Lynn	D26/35
D281,412	S *	11/1985	Barnhart	D12/190
D320,363	S *	10/1991	Lyons	D10/114.3
D415,296	S *	10/1999	Gavin	D26/28
D445,517	S *	7/2001	McGill	D26/28
D449,393	S *	10/2001	Yamamoto	D26/28

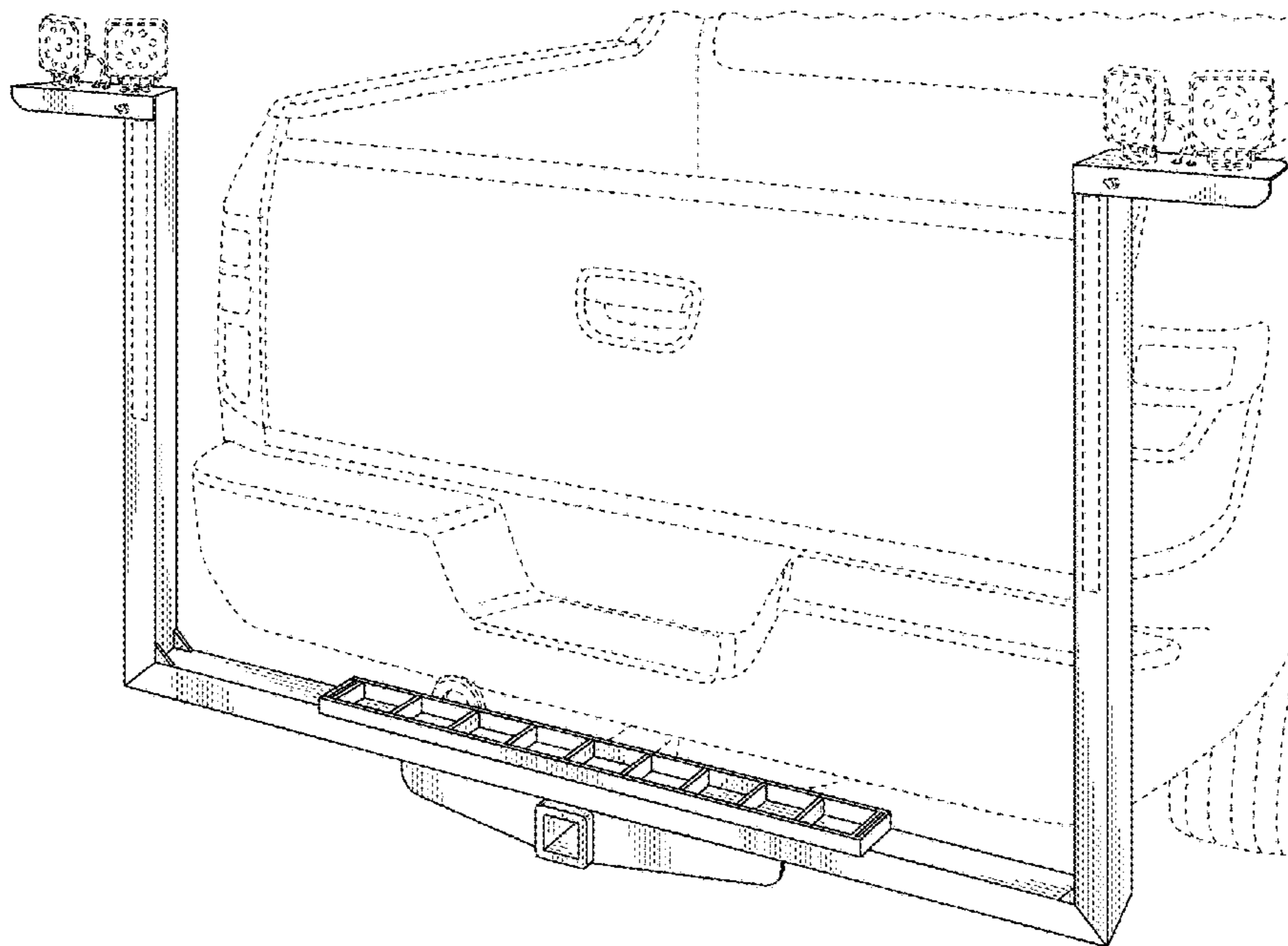

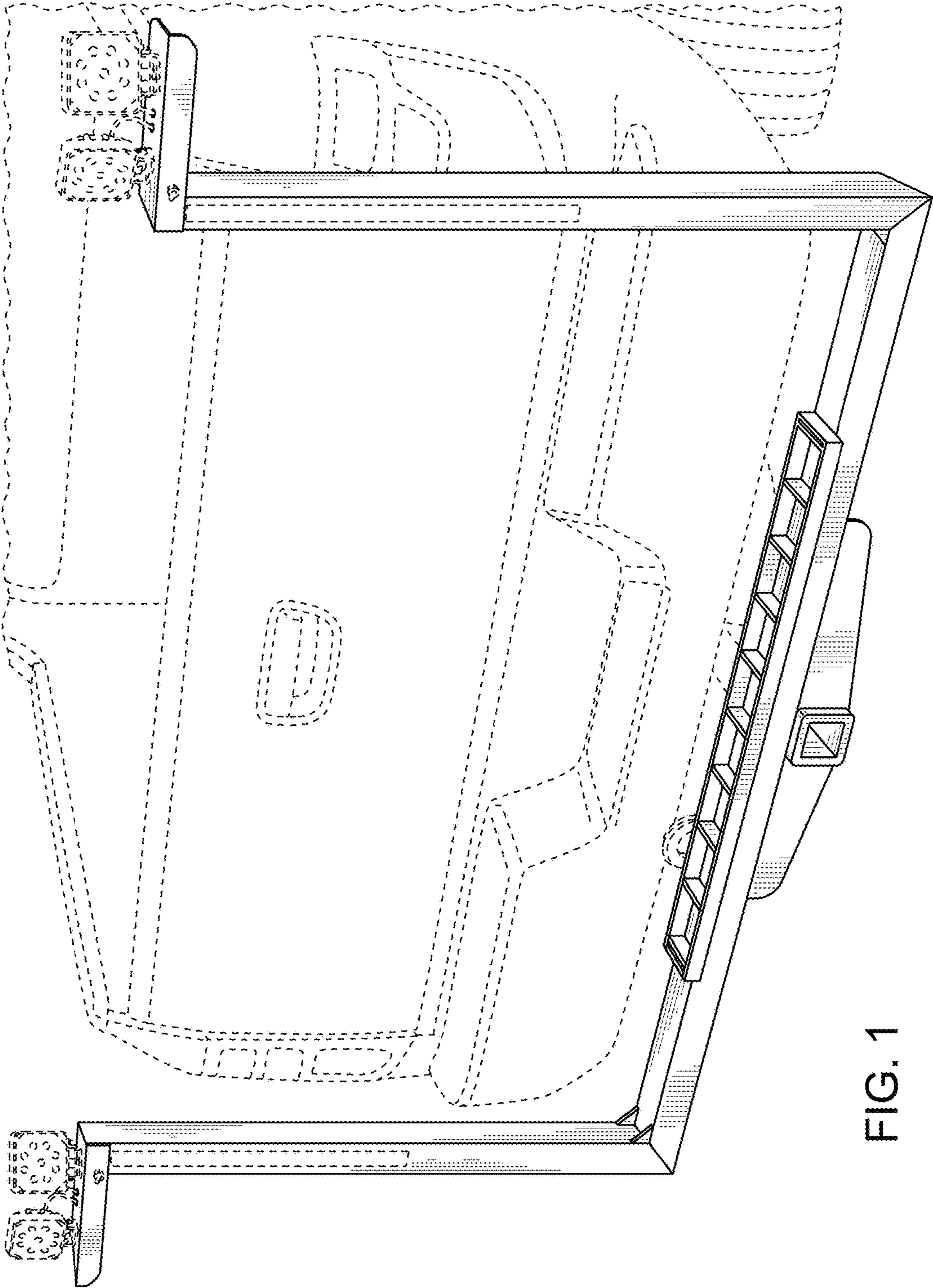
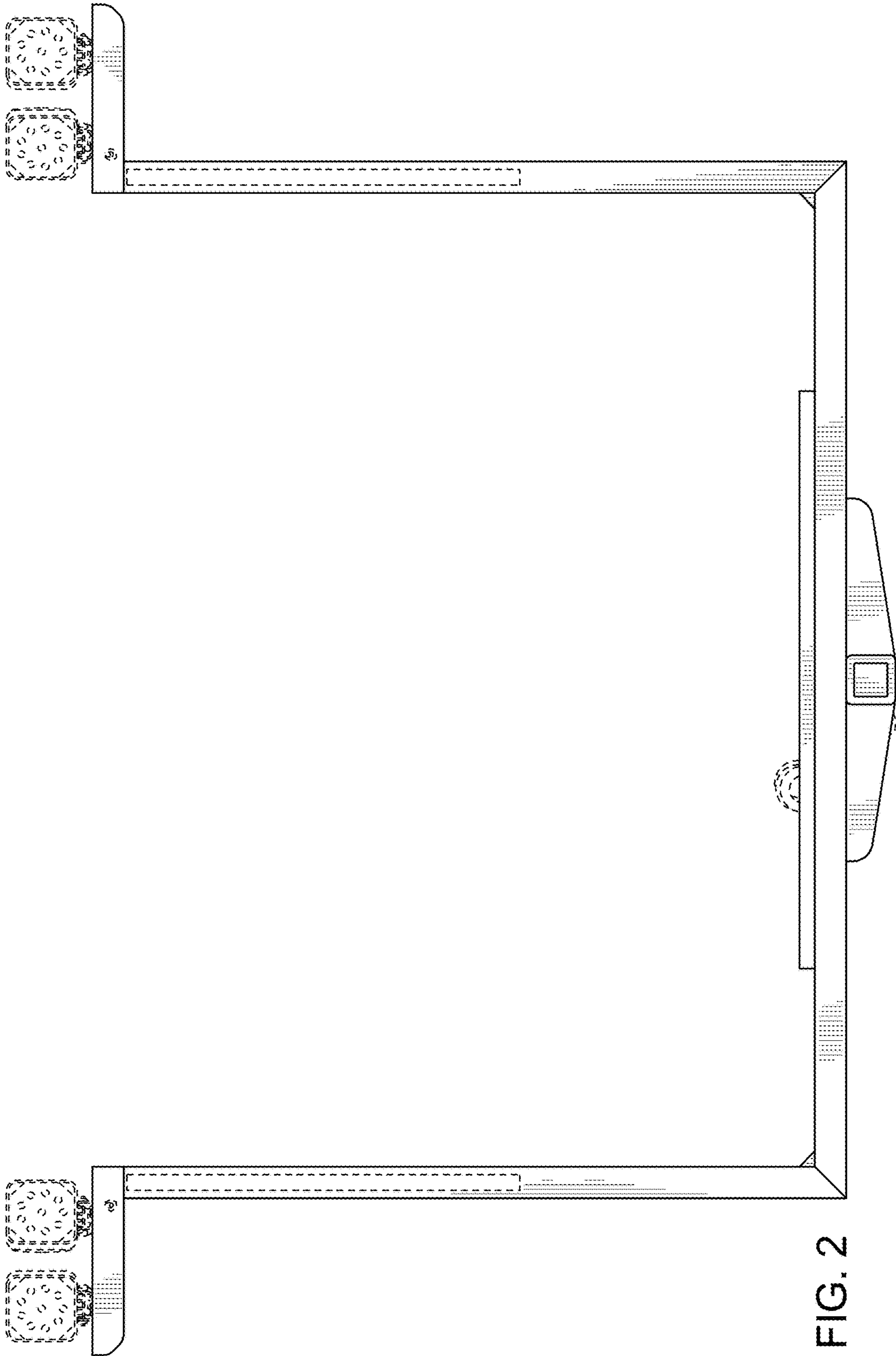

FIG. 1



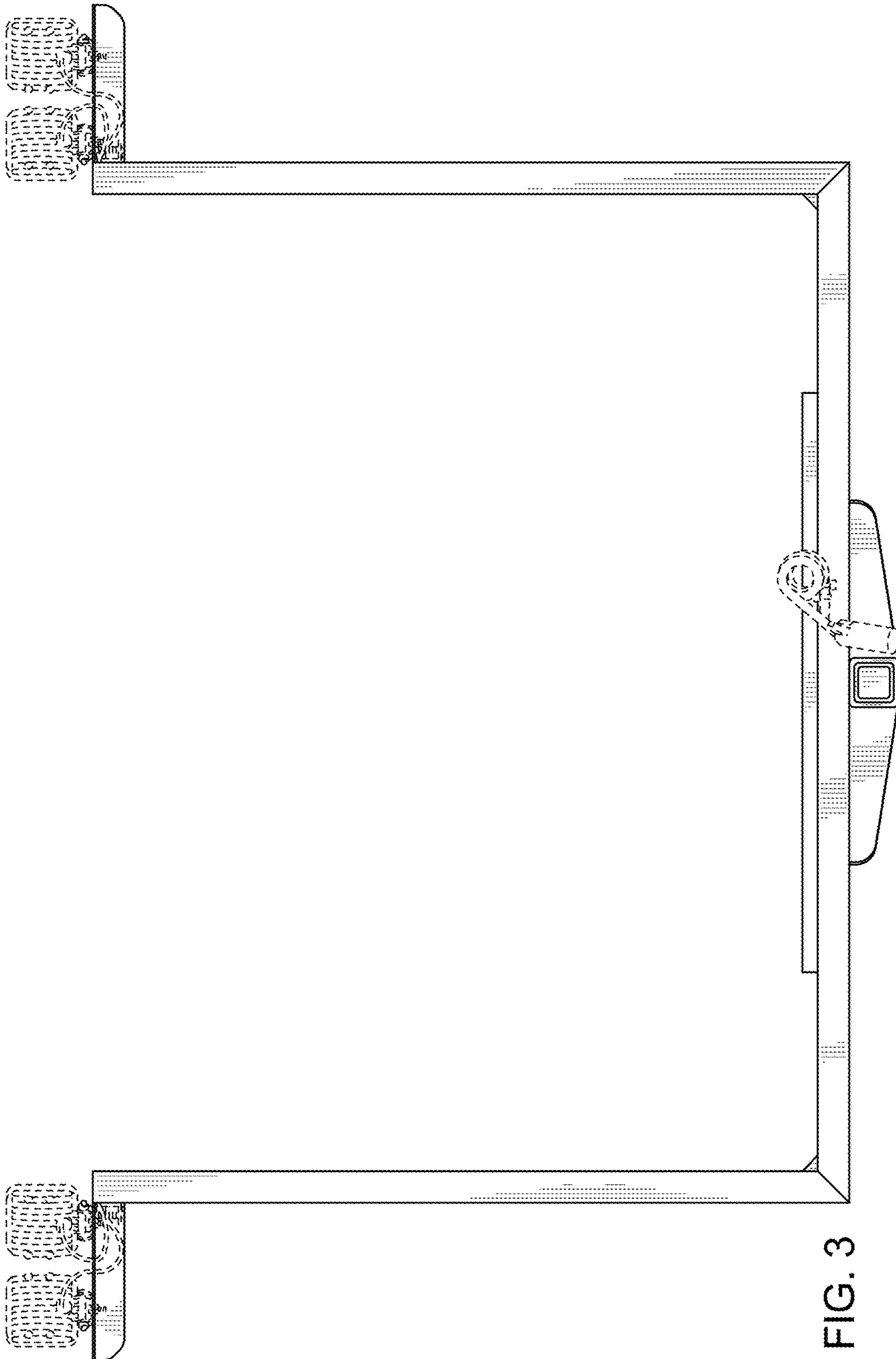

FIG. 3

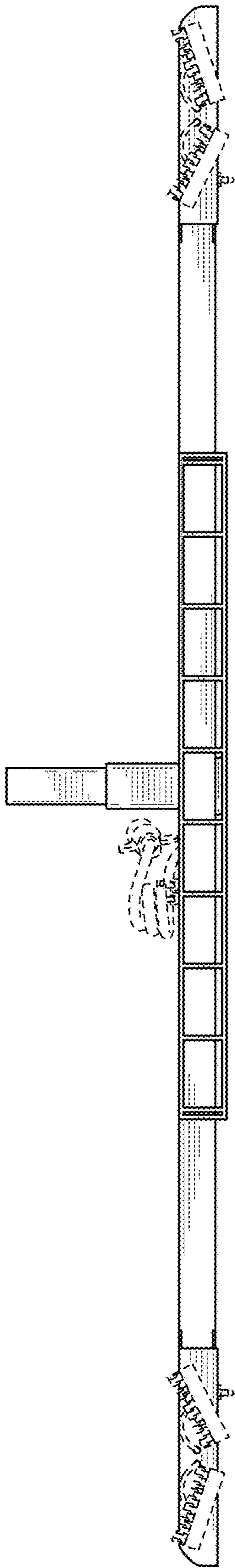

FIG. 4

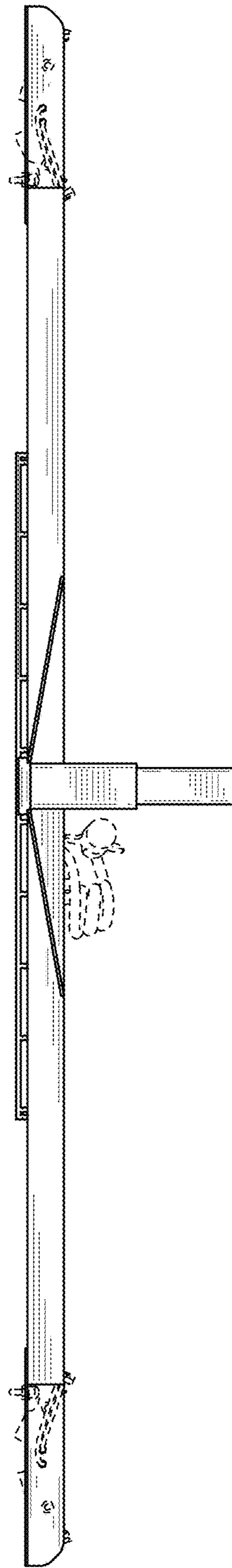

FIG. 5

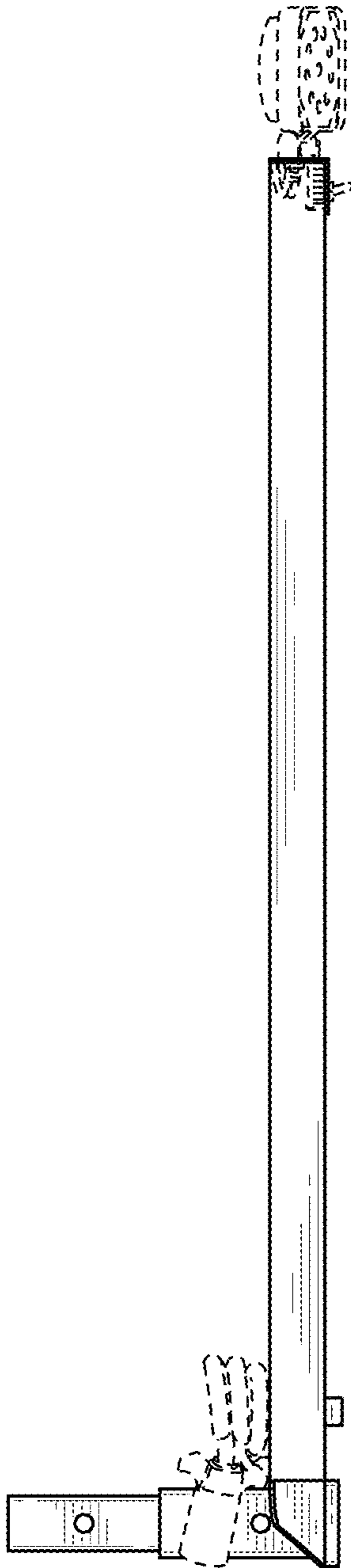

FIG. 6

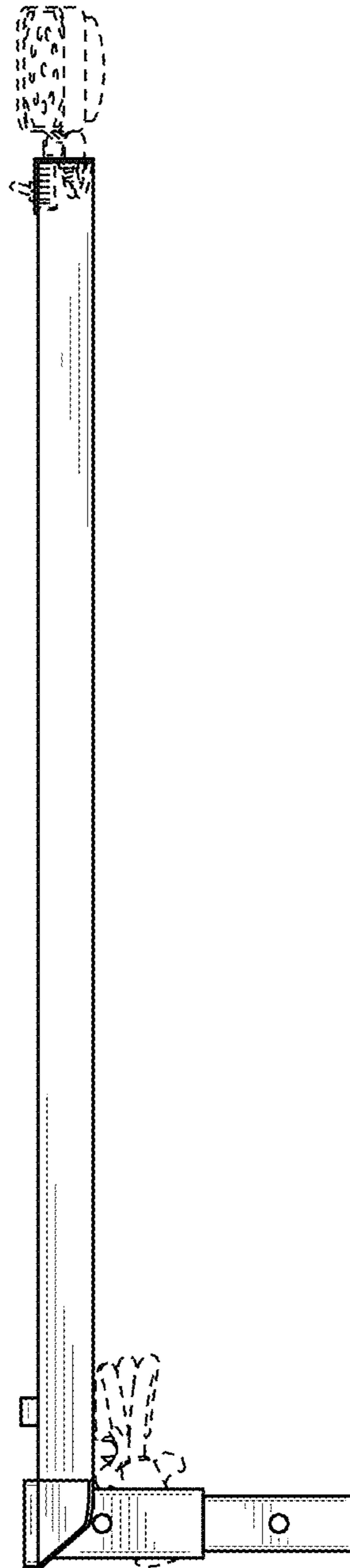

FIG. 7