



US00D777862S

(12) **United States Design Patent**  
**Sennett**

(10) **Patent No.:** **US D777,862 S**

(45) **Date of Patent:** **\*\* Jan. 31, 2017**

- (54) **TRANSPARENT PADDLEBOARD**
- (71) Applicant: **John Sennett**, New Port Richey, FL  
(US)
- (72) Inventor: **John Sennett**, New Port Richey, FL  
(US)
- (\*\*) Term: **15 Years**
- (21) Appl. No.: **29/540,491**
- (22) Filed: **Sep. 24, 2015**
- (51) **LOC (10) Cl.** ..... **21-02**
- (52) **U.S. Cl.**  
USPC ..... **D21/769**
- (58) **Field of Classification Search**  
USPC ..... D21/684-685, 760-761, 765-766,  
D21/768-777, 778, 803; 114/253,  
114/345-346; 441/74-75; 472/128-129;  
D12/5, 6, 316; 280/601, 609, 637, 11.36  
CPC ..... B63B 35/79; B63B 35/73; B63B 1/00  
See application file for complete search history.

- 7,238,075 B2 \* 7/2007 Brodsky ..... B63B 35/7906  
441/129
- 7,507,132 B2 \* 3/2009 Grune ..... B63B 35/7906  
114/66
- 7,811,144 B2 \* 10/2010 Cavanaugh ..... B63B 35/7906  
441/74
- 9,327,807 B1 \* 5/2016 Masson ..... B63B 35/7906
- 2005/0064774 A1 \* 3/2005 Grune ..... B63B 35/7906  
441/74
- 2005/0247248 A1 \* 11/2005 Caplan ..... B63B 35/7916  
114/66

\* cited by examiner

*Primary Examiner* — Zenia Bennett

(74) *Attorney, Agent, or Firm* — Gulf Coast Intellectual  
Property Group

(57) **CLAIM**

The ornamental design for a transparent paddleboard, as  
shown and described.

**DESCRIPTION**

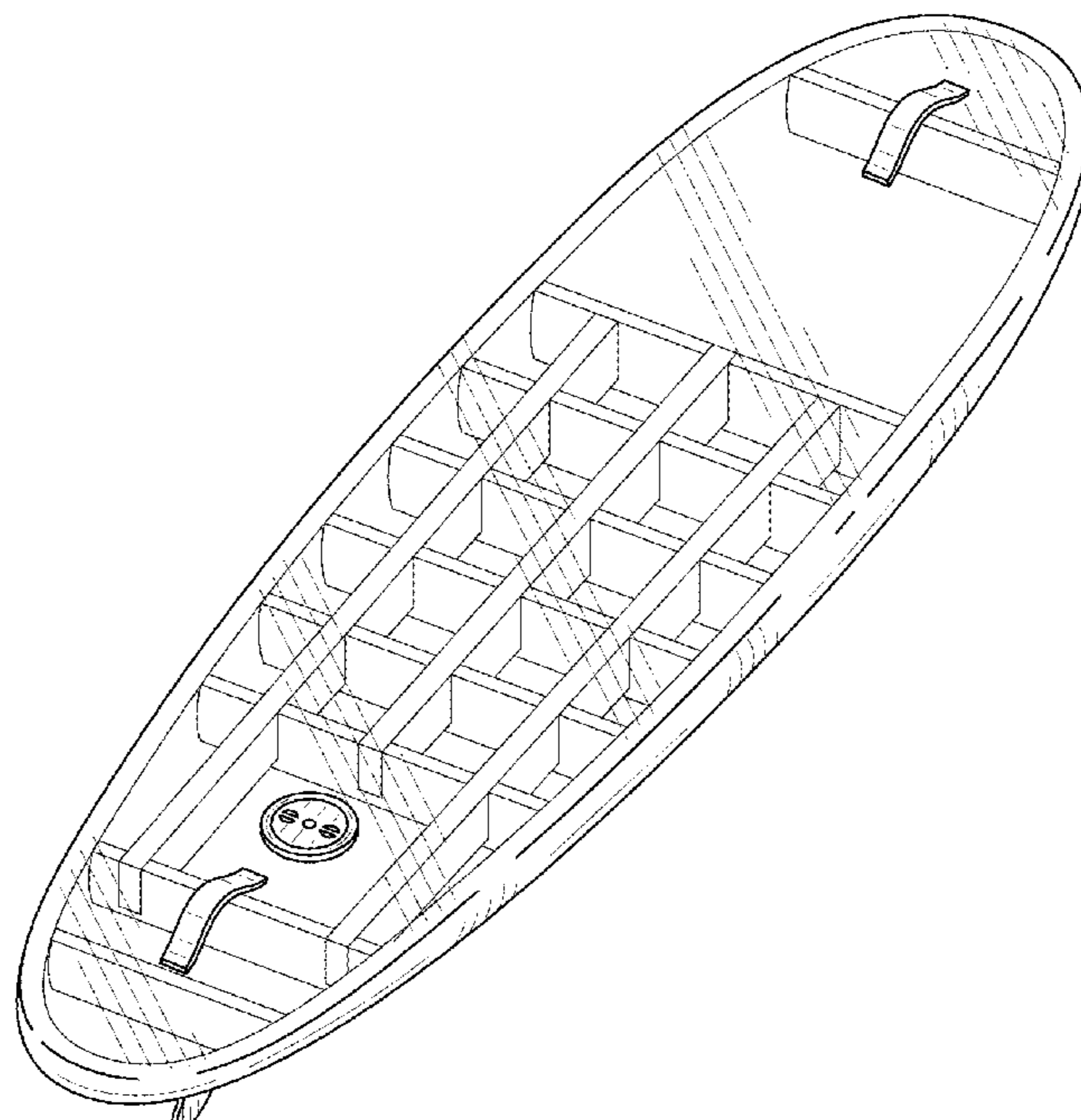
FIG. 1 is a perspective view of the present invention in its  
stored position; and  
FIG. 2 is a top plan view of the present invention; and  
FIG. 3 is a bottom plan of the present invention; and  
FIG. 4 is a left side view of the present invention; and  
FIG. 5 is a right side view of the present invention; and  
FIG. 6 is a front view of the present invention; and,  
FIG. 7 is a rear view of the present invention.

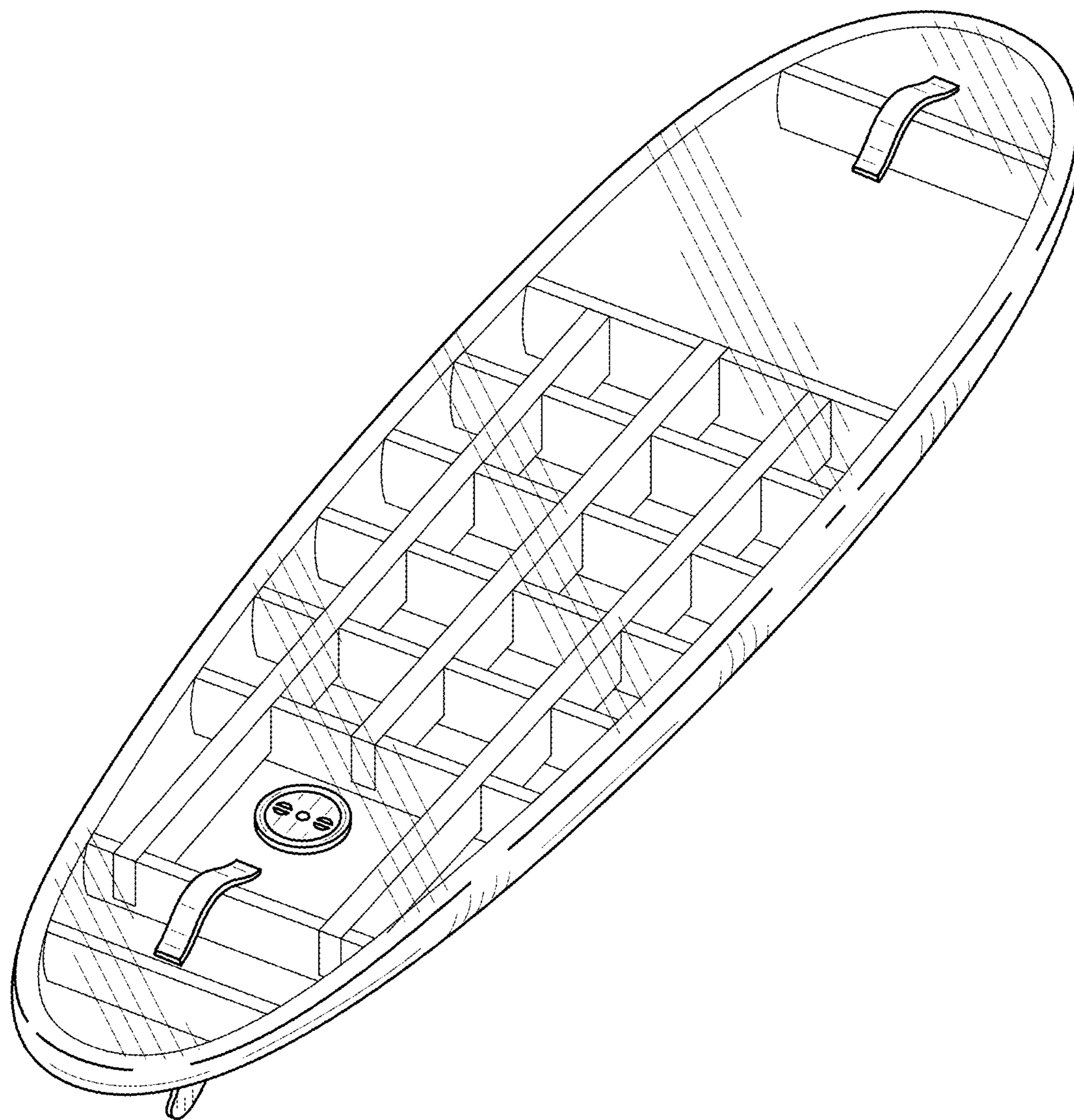
**1 Claim, 4 Drawing Sheets**

(56) **References Cited**

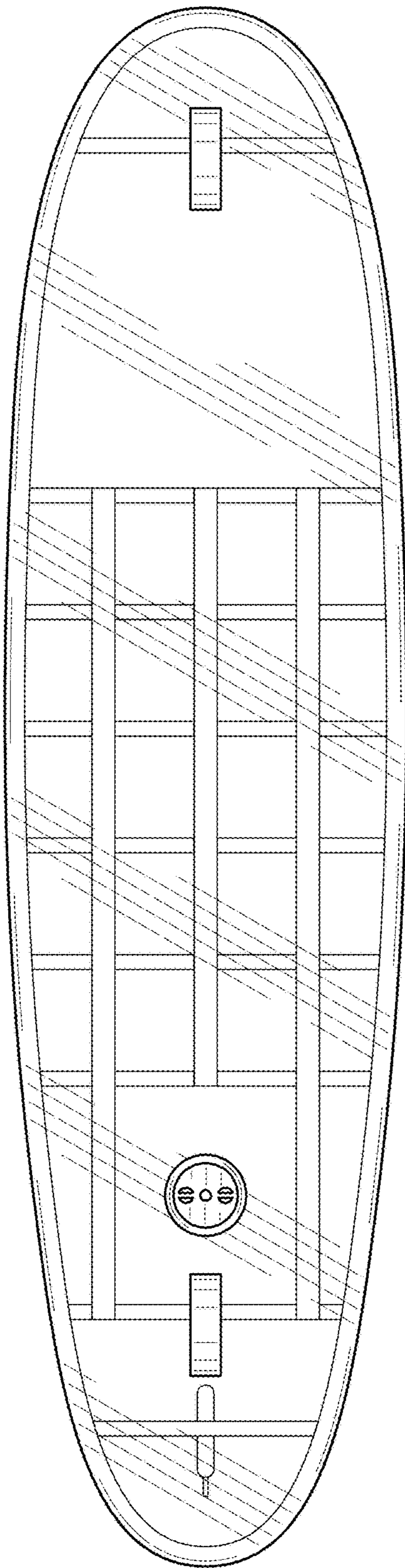
U.S. PATENT DOCUMENTS

- 4,209,867 A \* 7/1980 Abrams, III ..... B63B 35/7906  
280/610
- 4,840,592 A \* 6/1989 Anderson ..... B63B 35/7943  
114/66
- 4,925,417 A \* 5/1990 Warren ..... B63C 11/49  
114/66
- D378,692 S \* 4/1997 Lincoln ..... B63B 35/7906  
D21/769
- D503,206 S \* 3/2005 Debold ..... D21/769

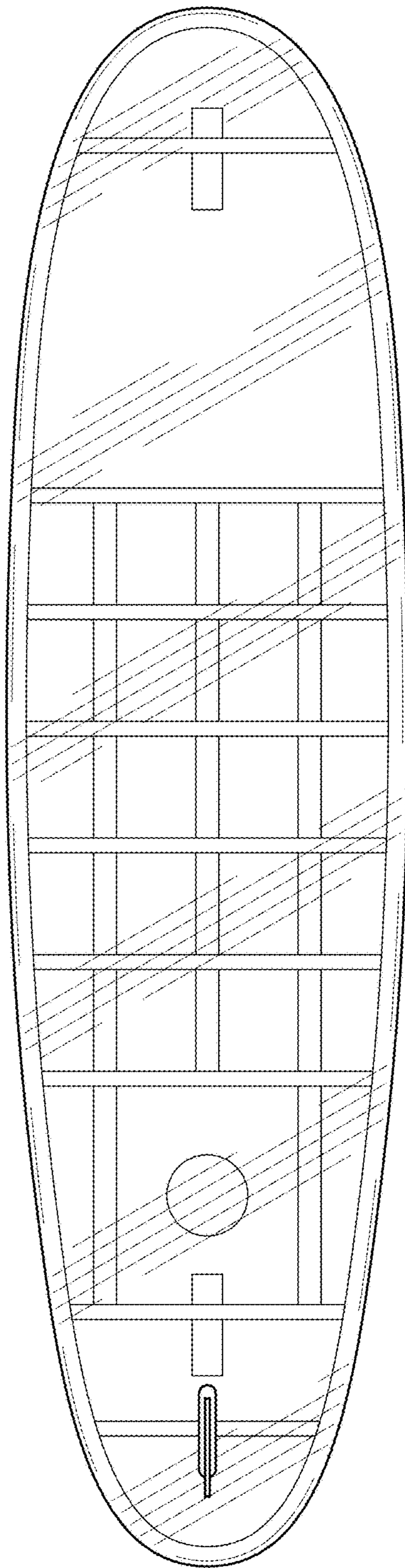




**FIG. 1**



**FIG. 2**



**FIG. 3**

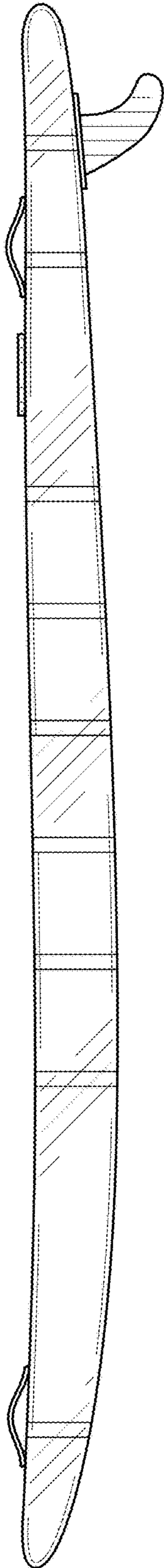


FIG. 4

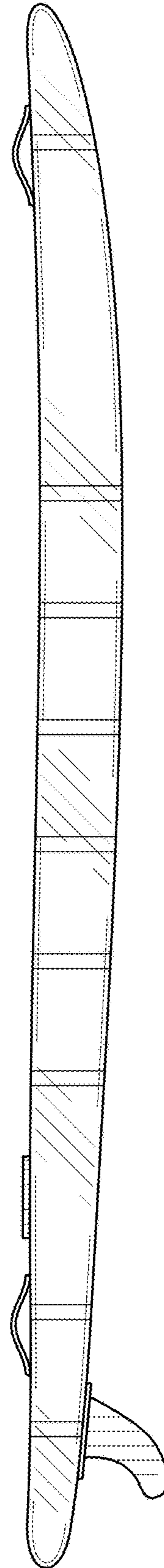
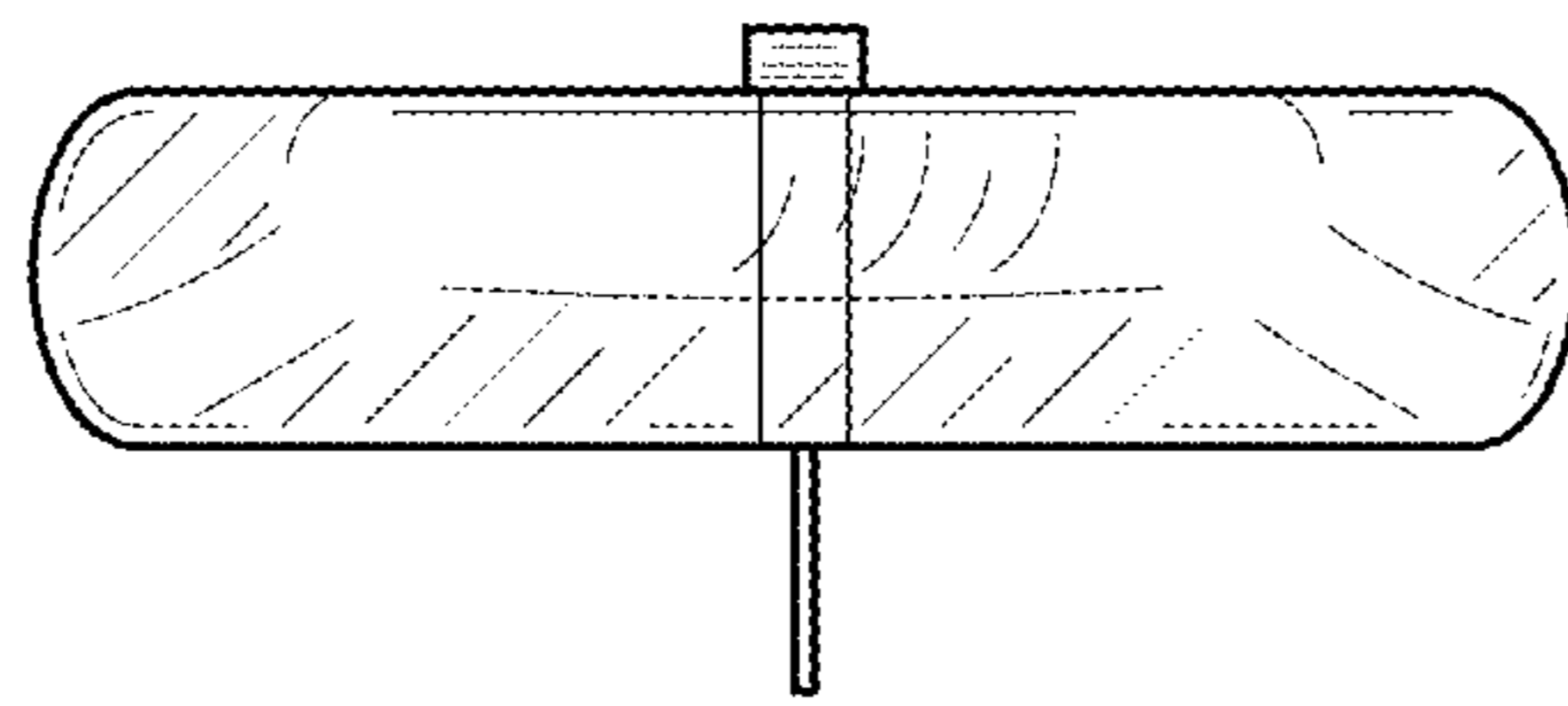
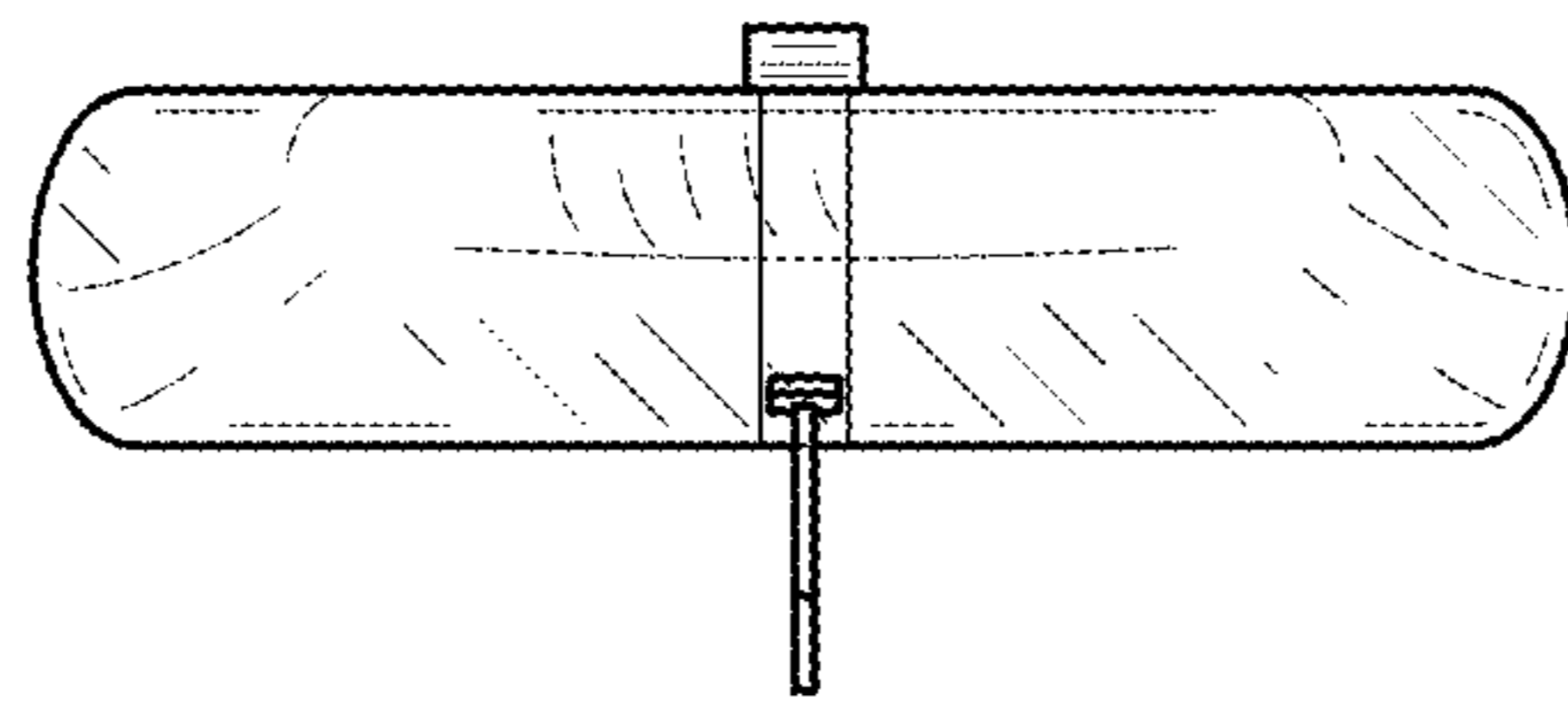


FIG. 5



**FIG. 6**



**FIG. 7**