



US00D777850S

(12) **United States Design Patent**  
**Kaye et al.**

(10) **Patent No.:** **US D777,850 S**

(45) **Date of Patent:** **\*\* Jan. 31, 2017**

(54) **VARIABLE RESISTANCE BAND**  
(71) Applicant: **ARQEX OUTDOOR FITNESS SYSTEMS, LLC**, Rye Brook, NY (US)  
(72) Inventors: **Eric A. Kaye**, Rye Brook, NY (US); **William C. Cesaroni**, Glenview, IL (US); **Morad Ghassemian**, Oak Park, IL (US); **Brian W. Mathews**, Waterman, IL (US); **Eugene L. DiMonte**, Aurora, IL (US); **Donovan D. Zielke**, Laguna Niguel, CA (US); **Steven M. Lenz**, Naperville, IL (US)

(73) Assignee: **ARQEX OUTDOOR FITNESS SYSTEMS, LLC**, Rye Brook, NY (US)

(\*\*) Term: **14 Years**

(21) Appl. No.: **29/514,787**

(22) Filed: **Jan. 16, 2015**

(51) **LOC (10) Cl.** ..... **21-02**

(52) **U.S. Cl.**  
USPC ..... **D21/692**

(58) **Field of Classification Search**  
USPC ..... D21/664, 673, 688, 662, 699, 705, D21/668, 769, 690, 788, 698, 534, 669, D21/302, 691, 681, 682, 800, 694, 686, D21/702, 676, 684, 775, 777, 692, 672; 482/122, 142, 123, 129, 128, 93, 106, 74, 482/121, 130, 71, 72, 95, 96, 68, 66, 41, 482/141, 100, 115, 49, 146, 147, 42, 51, 482/35, 38, 23, 904, 91, 28, 140, 907, 86, 482/83, 87, 90, 131, 902, 61, 65, 17, 52, 482/62, 107, 108, 54, 105, 133, 148, 92, 482/138, 12; 473/432, 445, 441, 197, 434, 473/438, 454, 478, 447, 422, 476; D12/317, 9, 6, 8, 130, 115, 114; 273/400, 273/407, 396; D8/303, 499, 107, 14; D11/87, 86, 80, 103, 2, 56, 93, 13; 16/430, 421; D26/49, 37; D24/107; 74/551.9; 59/82, 80; 24/658, 303

CPC ..... A63B 21/0552; A63B 21/00069; A63B 21/4035; A63B 21/0557; A63B 21/0442; A63B 2208/0204; A63B 21/4043; A63B 23/12; A63B 21/0004  
See application file for complete search history.

(56) **References Cited**

U.S. PATENT DOCUMENTS

145,642 A \* 12/1873 Frontier ..... A44C 5/107 59/82  
163,957 A 6/1875 Wood  
189,797 A \* 4/1877 Seery ..... A44C 11/00 59/80  
652,617 A 6/1900 Hotz  
1,539,569 A 5/1925 Hubert  
1,633,124 A 6/1927 Noe  
1,729,399 A 9/1929 Noe  
1,749,544 A 3/1930 Pagano  
2,930,614 A 3/1960 McIntosh  
3,141,214 A \* 7/1964 Bey ..... A44B 15/002 24/303  
3,345,067 A 10/1967 Smith  
3,528,656 A 9/1970 Haanen  
3,598,406 A 8/1971 Robinson  
3,680,858 A 8/1972 Ossenkop et al.  
3,759,514 A 9/1973 Cox  
3,765,064 A \* 10/1973 Hooper ..... A44C 5/2052 24/658  
3,815,904 A 6/1974 Weiss et al.  
4,057,246 A 11/1977 Wilson  
4,373,716 A 2/1983 Pagani  
D282,055 S \* 1/1986 Brinkers ..... D11/103  
D284,259 S \* 6/1986 Oury ..... D8/107  
4,620,701 A 11/1986 Mojden  
4,685,670 A 8/1987 Zinkin  
D299,807 S \* 2/1989 Sawa ..... D22/118  
D305,446 S \* 1/1990 Valentine ..... D21/672  
5,039,092 A 8/1991 Olschansky  
5,090,694 A 2/1992 Pauls et al.  
5,112,287 A 5/1992 Brewer  
5,205,803 A 4/1993 Zemitis  
5,211,617 A 5/1993 Millen  
5,269,737 A 12/1993 Sobotka  
5,288,074 A 2/1994 Scheurer  
5,431,610 A 7/1995 Miller  
5,431,617 A 7/1995 Rattray, Jr.  
5,496,246 A 3/1996 Pierre  
D377,462 S \* 1/1997 Kassardjian ..... D11/87  
5,626,546 A 5/1997 Little  
D388,356 S \* 12/1997 Lucas, II ..... D11/86

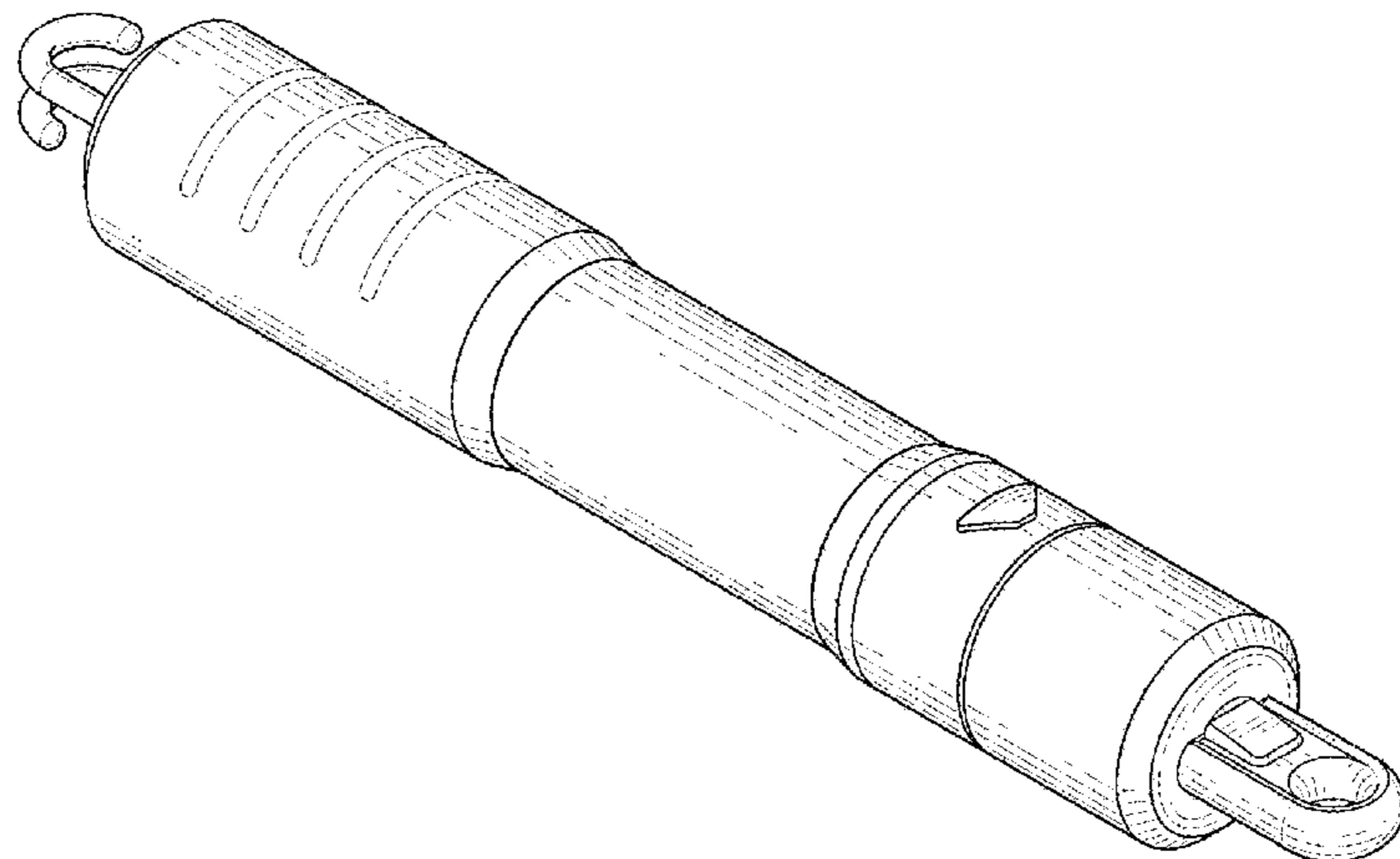

(56)

References Cited

U.S. PATENT DOCUMENTS

5,700,232 A 12/1997 Clausen et al.  
 5,839,997 A 11/1998 Roth et al.  
 5,876,313 A 3/1999 Krull  
 5,885,196 A 3/1999 Gvoich  
 5,997,448 A 12/1999 Duba  
 6,015,371 A 1/2000 Davitt  
 6,033,350 A 3/2000 Krull  
 D424,638 S \* 5/2000 Urso ..... D21/662  
 6,099,442 A 8/2000 Krull  
 6,142,919 A 11/2000 Jorgensen  
 6,186,927 B1 2/2001 Krull  
 6,202,263 B1 3/2001 Harker  
 6,238,324 B1 \* 5/2001 MacMillan ..... A63B 21/00043  
 482/12  
 6,322,481 B1 11/2001 Krull  
 6,322,483 B1 11/2001 Rotella  
 6,402,666 B2 6/2002 Krull  
 6,416,446 B1 7/2002 Krull  
 6,422,979 B1 7/2002 Krull  
 D470,902 S \* 2/2003 Davies ..... D21/662  
 6,554,747 B1 4/2003 Rempe  
 6,561,956 B1 5/2003 Allison  
 D475,911 S \* 6/2003 Vito ..... D8/499  
 D476,557 S \* 7/2003 Vito ..... D8/499  
 D477,853 S \* 7/2003 Davies ..... D21/672  
 D478,391 S \* 8/2003 Saunders ..... D26/49  
 6,626,801 B2 9/2003 Marques  
 6,629,910 B1 10/2003 Krull  
 6,669,606 B2 12/2003 Krull  
 D484,929 S \* 1/2004 Mollet ..... D21/662  
 6,676,576 B1 1/2004 Wu  
 6,679,816 B1 1/2004 Krull  
 6,733,424 B2 5/2004 Krull  
 6,746,381 B2 6/2004 Krull  
 6,749,547 B2 6/2004 Krull  
 6,848,288 B1 \* 2/2005 Derman ..... A44B 15/002  
 24/303  
 6,872,173 B2 3/2005 Krull  
 6,899,661 B1 5/2005 Krull  
 6,902,515 B2 6/2005 Howell et al.  
 6,902,516 B2 6/2005 Krull  
 6,908,418 B2 6/2005 Saure  
 6,974,405 B2 12/2005 Krull  
 7,032,529 B2 4/2006 Sanford  
 7,037,246 B2 5/2006 Kim  
 7,041,041 B1 5/2006 Evans  
 7,060,011 B1 6/2006 Krull  
 7,121,988 B2 10/2006 Walkerdine  
 7,128,697 B1 10/2006 Krull  
 7,153,243 B1 12/2006 Krull  
 7,192,390 B2 3/2007 Berard  
 7,192,391 B2 3/2007 Kim  
 7,229,392 B2 6/2007 Turnbull et al.  
 7,250,022 B2 7/2007 Dalebout et al.  
 7,264,578 B1 9/2007 Krull  
 D561,636 S \* 2/2008 Khubani ..... D11/87  
 7,331,909 B2 2/2008 Middleton  
 7,334,499 B2 \* 2/2008 Lai ..... B62K 21/26  
 74/551.9  
 7,377,886 B2 5/2008 Wu  
 7,429,236 B2 9/2008 Dalebout et al.  
 7,455,632 B2 11/2008 Block et al.  
 7,497,814 B1 3/2009 Krull  
 7,510,539 B2 3/2009 Katane et al.  
 7,547,268 B1 6/2009 Krull  
 7,553,265 B2 6/2009 Crawford et al.  
 D596,476 S \* 7/2009 Welch ..... D8/303  
 7,572,212 B2 8/2009 Cassidy et al.  
 7,578,775 B2 8/2009 Terry  
 7,585,260 B2 \* 9/2009 Ma ..... A63B 21/0552  
 482/106  
 7,588,520 B2 9/2009 Nalley  
 D601,915 S \* 10/2009 Heroux ..... D11/87  
 7,611,450 B2 11/2009 Mancini  
 7,621,856 B1 11/2009 Keith et al.

7,625,325 B1 12/2009 Yost  
 7,632,221 B1 12/2009 Kolander  
 D607,591 S \* 1/2010 Rivera ..... D26/49  
 7,662,074 B2 2/2010 Webb  
 D615,605 S \* 5/2010 Frasco ..... D21/682  
 7,736,286 B2 6/2010 Panaiotov  
 7,740,568 B2 6/2010 Webb  
 D621,680 S \* 8/2010 Hsu ..... D8/303  
 7,766,804 B2 8/2010 Placencia  
 7,775,949 B2 8/2010 Bowser  
 7,785,242 B2 8/2010 Solomon  
 7,785,243 B2 8/2010 Kassel  
 7,794,373 B2 9/2010 Crawford et al.  
 7,794,374 B1 9/2010 Park  
 7,798,945 B2 9/2010 Ko  
 7,798,946 B2 9/2010 Dalebout et al.  
 7,819,787 B2 10/2010 Kassel  
 D626,609 S 11/2010 Grider  
 7,857,739 B2 12/2010 Caldwell  
 7,878,954 B2 2/2011 McBride et al.  
 7,878,955 B1 2/2011 Ehrlich et al.  
 7,878,956 B2 2/2011 Kadar et al.  
 7,892,155 B2 2/2011 Pearson et al.  
 7,914,426 B1 3/2011 Lie  
 7,922,635 B2 4/2011 Lull et al.  
 D639,355 S 6/2011 Kassel  
 D639,356 S 6/2011 Kassel  
 D644,700 S 9/2011 Kassel  
 D645,919 S 9/2011 Kassel et al.  
 8,016,729 B2 9/2011 Webb  
 8,021,286 B2 9/2011 Suiter  
 8,033,960 B1 10/2011 Dalebout et al.  
 8,033,966 B2 \* 10/2011 Ayoub ..... A63B 23/1209  
 482/121  
 8,057,371 B2 11/2011 McBride et al.  
 8,109,864 B2 2/2012 Tseng  
 8,137,248 B1 3/2012 Krull  
 8,152,703 B1 4/2012 Hinds  
 8,246,524 B2 8/2012 Castillo  
 D667,130 S \* 9/2012 Baker ..... D24/207  
 8,272,996 B2 9/2012 Weier  
 8,273,001 B2 9/2012 Karecki et al.  
 8,287,438 B2 10/2012 Krull  
 8,303,472 B2 11/2012 Bowser  
 8,317,660 B2 11/2012 Goranson  
 8,317,667 B1 11/2012 Thomas  
 8,485,946 B2 7/2013 Ross et al.  
 8,496,567 B2 7/2013 Mayaud  
 8,499,383 B1 8/2013 Ungaro  
 8,602,951 B2 12/2013 Morris  
 8,602,952 B1 12/2013 Cruz  
 8,657,727 B1 2/2014 Kassel et al.  
 8,690,741 B2 4/2014 Ross et al.  
 8,696,529 B2 4/2014 Krull  
 8,821,359 B1 9/2014 Kassel  
 8,870,722 B2 10/2014 Kassel  
 8,905,905 B2 12/2014 Mangalindan  
 9,414,667 B1 \* 8/2016 Tate ..... A45F 3/44  
 2003/0017918 A1 1/2003 Webb et al.  
 2003/0232707 A1 12/2003 Dalebout et al.  
 2004/0009854 A1 1/2004 Shiang et al.  
 2005/0043150 A1 2/2005 Nitta et al.  
 2005/0049121 A1 3/2005 Dalebout et al.  
 2005/0113219 A1 5/2005 Pierre, II  
 2005/0130814 A1 6/2005 Nitta et al.  
 2005/0272577 A1 12/2005 Olson et al.  
 2006/0035768 A1 2/2006 Kowallis et al.  
 2006/0128540 A1 6/2006 Engle  
 2007/0143968 A1 \* 6/2007 Tseng ..... A45B 9/02  
 16/430  
 2007/0207903 A1 9/2007 Csabai  
 2007/0207904 A1 9/2007 Wu  
 2008/0156139 A1 \* 7/2008 Lai ..... B62K 21/26  
 74/551.9  
 2009/0137371 A1 5/2009 Fuller  
 2009/0215594 A1 8/2009 Panaiotov  
 2010/0016132 A1 1/2010 Flynn  
 2010/0048368 A1 2/2010 Donofrio  
 2010/0331152 A1 12/2010 Pedrera

(56)

**References Cited**

U.S. PATENT DOCUMENTS

2011/0124476	A1	5/2011	Holley	
2011/0237410	A1	9/2011	Perez	
2011/0269604	A1	11/2011	Tseng	
2012/0058864	A1	3/2012	Mizrachy	
2012/0214651	A1	8/2012	Ross	
2013/0225371	A1	8/2013	Harrer et al.	
2013/0225372	A1	8/2013	Rochford	
2013/0225376	A1	8/2013	Kinsbourne et al.	
2014/0066274	A1	3/2014	Kassel	
2014/0274606	A1*	9/2014	Piskin	..... A63B 21/0442 482/129
2015/0126342	A1*	5/2015	Kaye	..... A63B 21/0442 482/121
2015/0126345	A1*	5/2015	Kaye	..... A63B 21/0442 482/129
2015/0126346	A1*	5/2015	Kaye	..... A63B 21/0442 482/129
2015/0126347	A1*	5/2015	Kaye	..... A63B 21/0442 482/129
2015/0133276	A1*	5/2015	Kaye	..... A63B 21/0557 482/129

FOREIGN PATENT DOCUMENTS

DE	20305669	10/2003
DE	102010051083	8/2011
WO	2014/036123	3/2014

OTHER PUBLICATIONS

Arqex Fitness by Arqex Fitness dated Apr. 30, 2016. Found online [Sep. 29, 2016] <http://yooying.com/p/1183633190801543590>.\*  
 “Bollinger Fitness 3-in-1 Adjustable Resistance Band”, [www.kmart.com](http://www.kmart.com), <http://www.kmart.com/bollinger-fitness-3-in-1-adjustable-resistance-band/p080V006270873000P>, 1 page, accessed Oct. 15, 2013.

“SKLZ Quick Change Resistance Band System”, [www.amazon.com](http://www.amazon.com), <http://www.amazon.com/SKLZ-QuickchangeResistanceSystem/dp/B00C81JUSM>, 8 pages, accessed Oct. 15, 2013.

“Lifeline USA TNT Special Triple Resistance Cable”, [www.amazon.com](http://www.amazon.com), [http://www.amazon.com/Lifeline-Special-Triple-Resistance-Cable/dp/B00069CP26/ref=pd\\_sbs\\_sg\\_3/189-4395354-1488107](http://www.amazon.com/Lifeline-Special-Triple-Resistance-Cable/dp/B00069CP26/ref=pd_sbs_sg_3/189-4395354-1488107), 7 pages, accessed Oct. 15, 2013.

“Resistance Bands”, <http://bandresistance.com>, 4 pages, accessed Oct. 15, 2013.

\* cited by examiner

*Primary Examiner* — Robert M Spear

*Assistant Examiner* — Ryan Harvey

(74) *Attorney, Agent, or Firm* — Tarter Krinsky & Drogin LLP

(57)

**CLAIM**

The ornamental design for a variable resistance band, as shown and described.

**DESCRIPTION**

FIG. 1 is a perspective view of the variable resistance band of the present invention;

FIG. 2 is a top view thereof and wherein an opposite bottom view is a mirror image thereof;

FIG. 3 is a first side view thereof and wherein an opposite second side view is a mirror image thereof;

FIG. 4 is an end view thereof taken along view line 4-4 in FIG-3; and,

FIG. 5 is an end view thereof taken along view line 5-5 in FIG-3.

The broken lines illustrate portions of the variable resistance band which form no part of the claimed design.

**1 Claim, 2 Drawing Sheets**

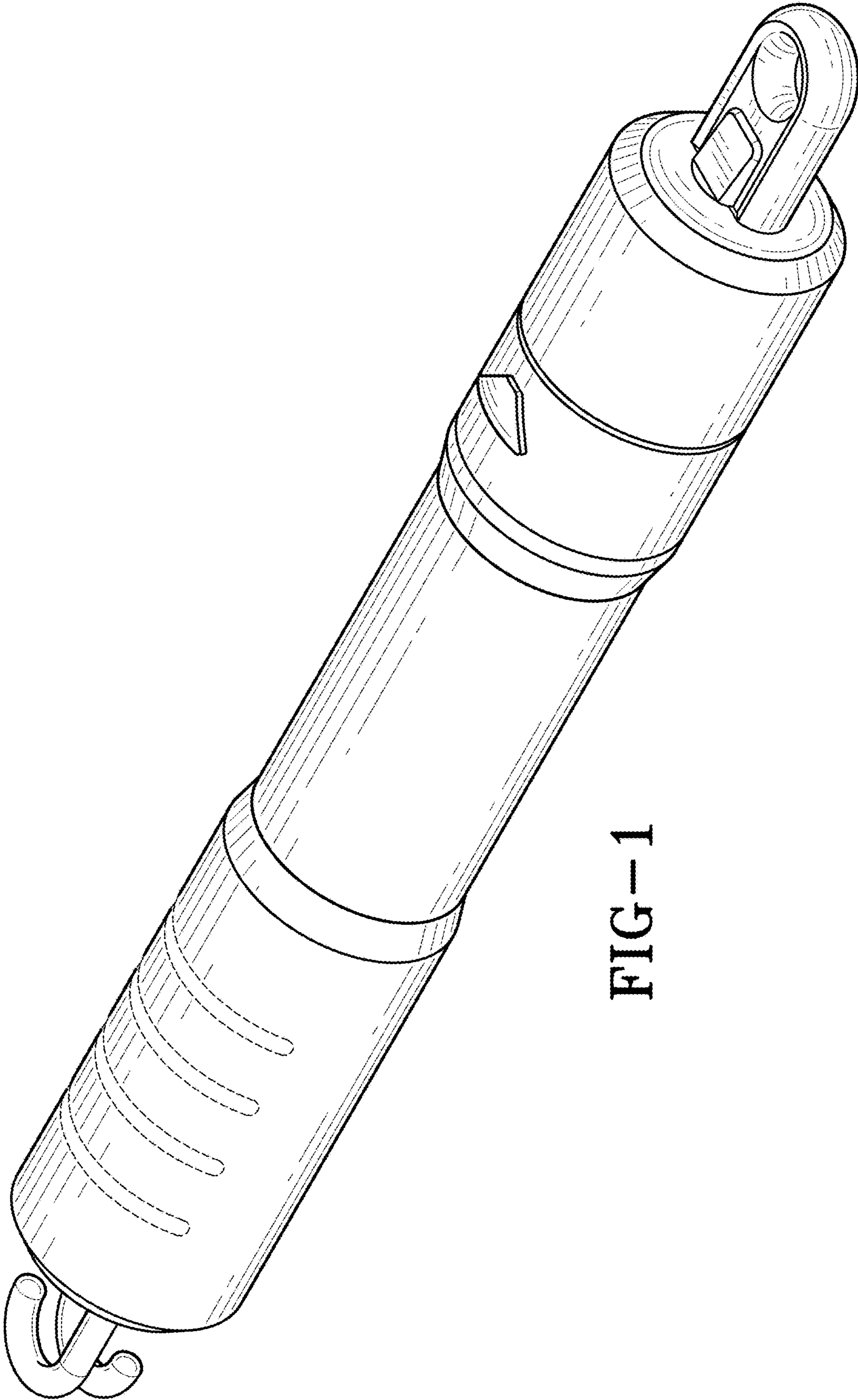

FIG-1

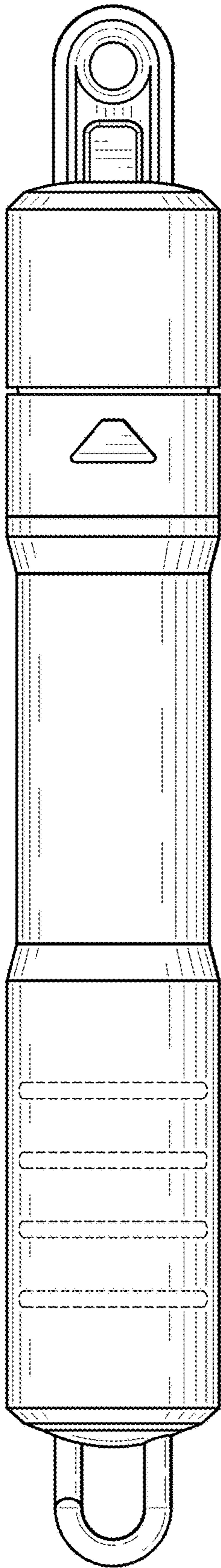

FIG-2

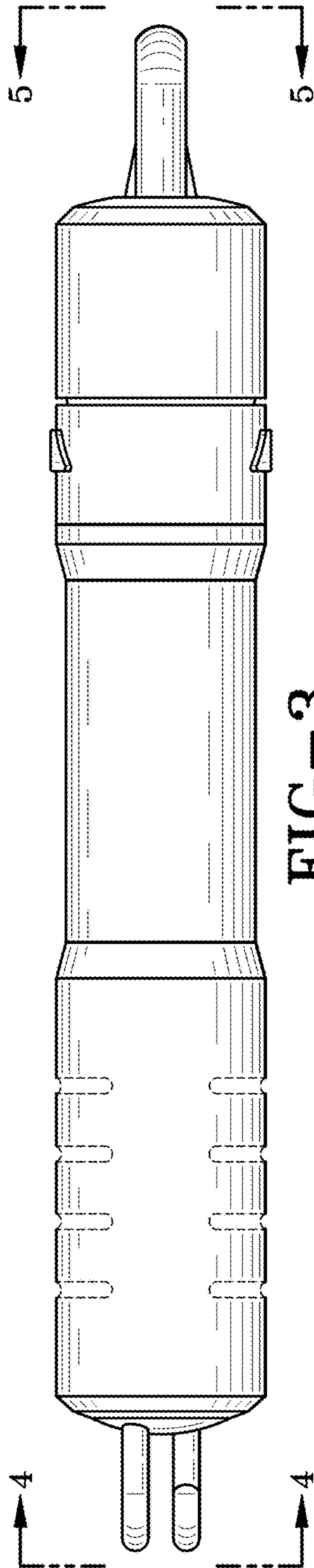

FIG-3

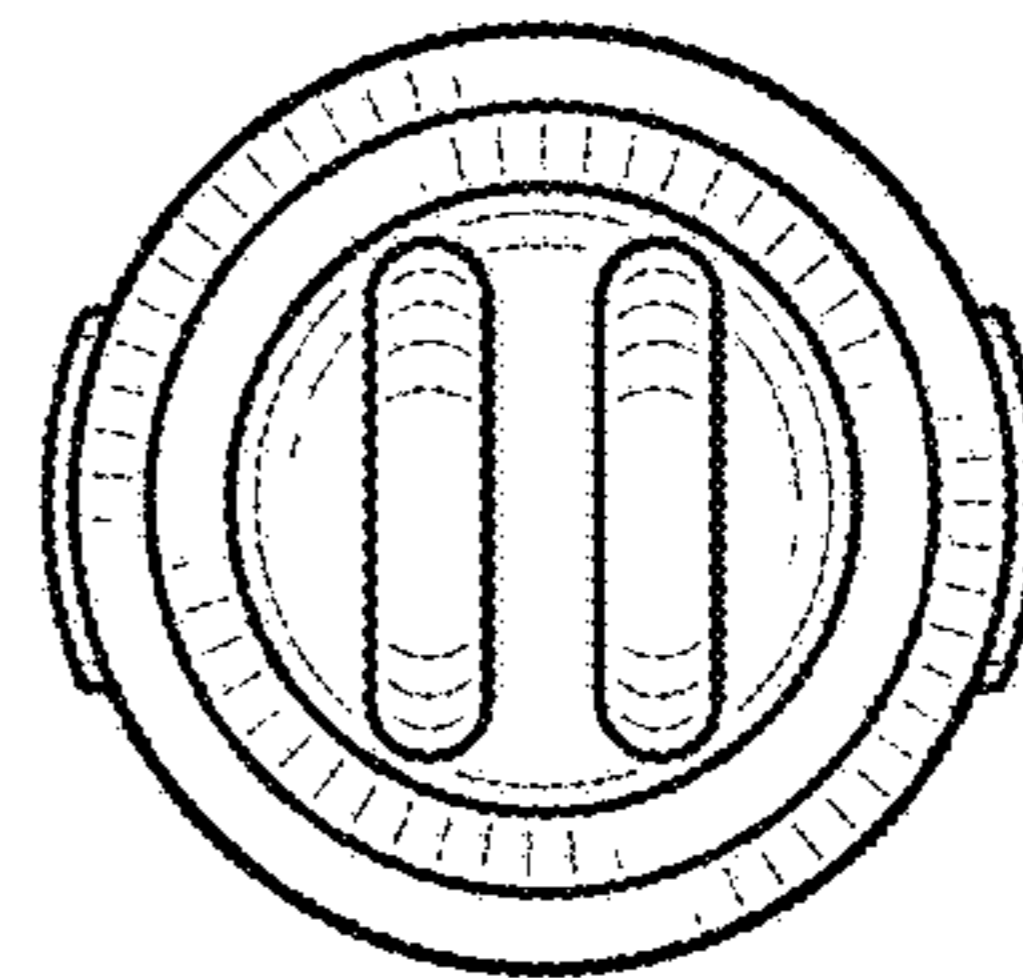

FIG-4

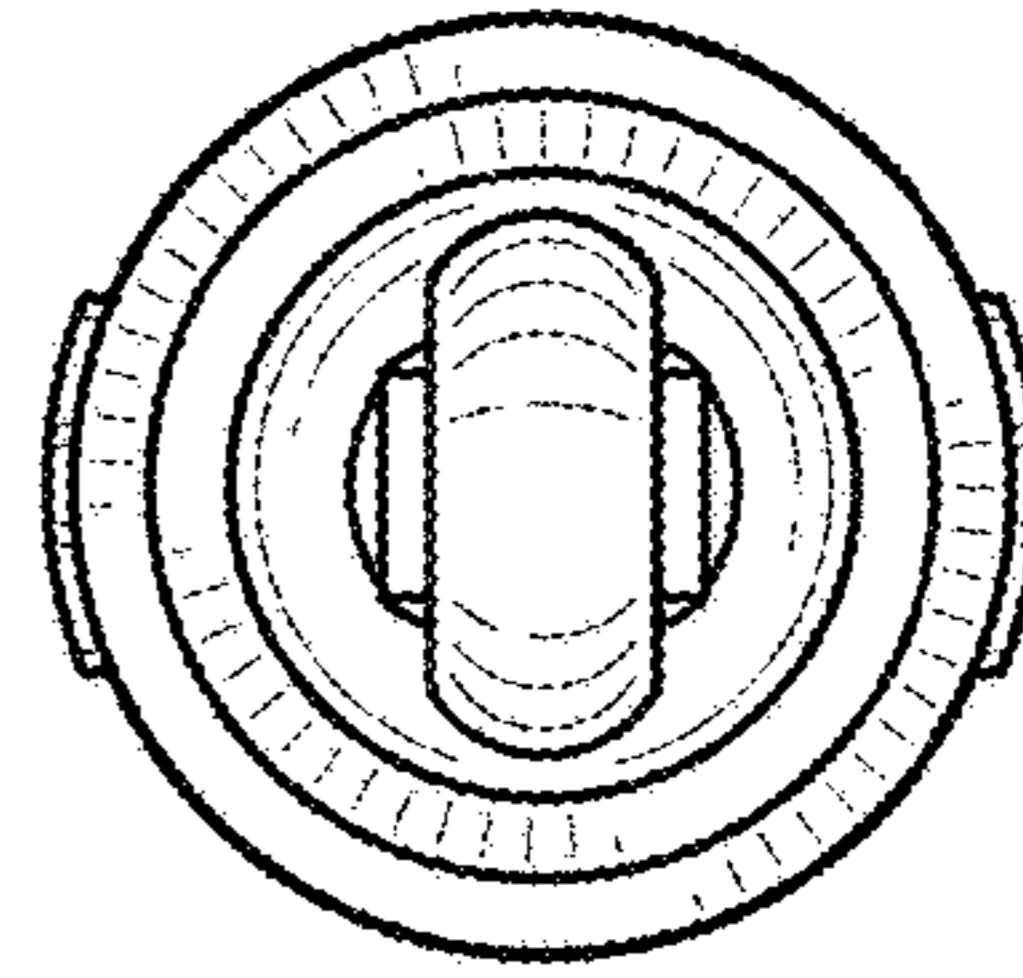

FIG-5