



US00D777831S

(12) **United States Design Patent** (10) **Patent No.:** **US D777,831 S**  
**Anderson et al.** (45) **Date of Patent:** **\*\* Jan. 31, 2017**

(54) **CASSETTE**  
(71) Applicant: **ABBVIE INC.**, North Chicago, IL (US)  
(72) Inventors: **Phil D. Anderson**, Libertyville, IL (US); **Ted Hanagan**, Libertyville, IL (US); **Kevin Novak**, Park Ridge, IL (US); **Gurjinder Dhami**, Neenah, WI (US); **Scott Smieja**, Oshkosh, WI (US); **Jeff Schacherl**, Neenah, WI (US); **Gary Friederichs**, Chilton, WI (US)

5,928,196 A 7/1999 Johnson et al.  
5,935,099 A 8/1999 Peterson et al.  
6,077,055 A 6/2000 Vilks  
6,243,117 B1 \* 6/2001 Brandon ..... B41J 2/17513  
347/87  
6,371,732 B1 4/2002 Moubayed et al.  
6,422,057 B1 7/2002 Anderson  
(Continued)

(73) Assignee: **ABBVIE INC.**, North Chicago, IL (US)  
(\*\*) Term: **14 Years**

**FOREIGN PATENT DOCUMENTS**

JP 2005-351131 A 12/2005  
JP 2005 351131 A 12/2005

(21) Appl. No.: **29/513,435**  
(22) Filed: **Dec. 30, 2014**  
(51) **LOC (10) Cl.** ..... **16-03**  
(52) **U.S. Cl.**  
USPC ..... **D18/43**  
(58) **Field of Classification Search**  
USPC ..... D18/12, 18, 40, 43, 56, 99  
CPC ..... G03G 15/0832; G03G 15/0834; G03G  
15/0836; G03G 15/0837; G03G 15/0867;  
G03G 15/0868; G03G 15/0872; G03G  
15/0877; G03G 15/0898; G03G  
15/50; G03G 15/5016; G03G  
15/60; G03G 15/65  
See application file for complete search history.

**OTHER PUBLICATIONS**

U.S. Appl. No. 15/064,481, filed Mar. 8, 2016.  
(Continued)

*Primary Examiner* — Daniel Bui  
*Assistant Examiner* — Khawaja Anwar  
(74) *Attorney, Agent, or Firm* — Baker Botts L.L.P.

(56) **References Cited**  
**U.S. PATENT DOCUMENTS**  
4,537,561 A 8/1985 Xanthopoulos  
5,131,816 A 7/1992 Brown et al.  
5,181,910 A 1/1993 Scanlon  
D348,730 S 7/1994 Walker et al.  
5,397,222 A 3/1995 Moss et al.  
5,538,399 A 7/1996 Johnson  
D376,796 S \* 12/1996 Hirasawa ..... D14/476  
5,755,691 A 5/1998 Hilborne

(57) **CLAIM**  
The ornamental design for a cassette, as shown and described.

**DESCRIPTION**

FIG. 1 is a perspective view of a cassette, showing our new design;  
FIG. 2 is a front view thereof;  
FIG. 3 is a rear view thereof;  
FIG. 4 is a left side view thereof;  
FIG. 5 is a right side view thereof;  
FIG. 6 is a top view thereof; and,  
FIG. 7 is a bottom view thereof.  
The broken lines shown throughout these figures depict environmental subject matter only and form no part of the claimed design. The dash-dot lines represent the boundaries of the claimed design.

**1 Claim, 6 Drawing Sheets**

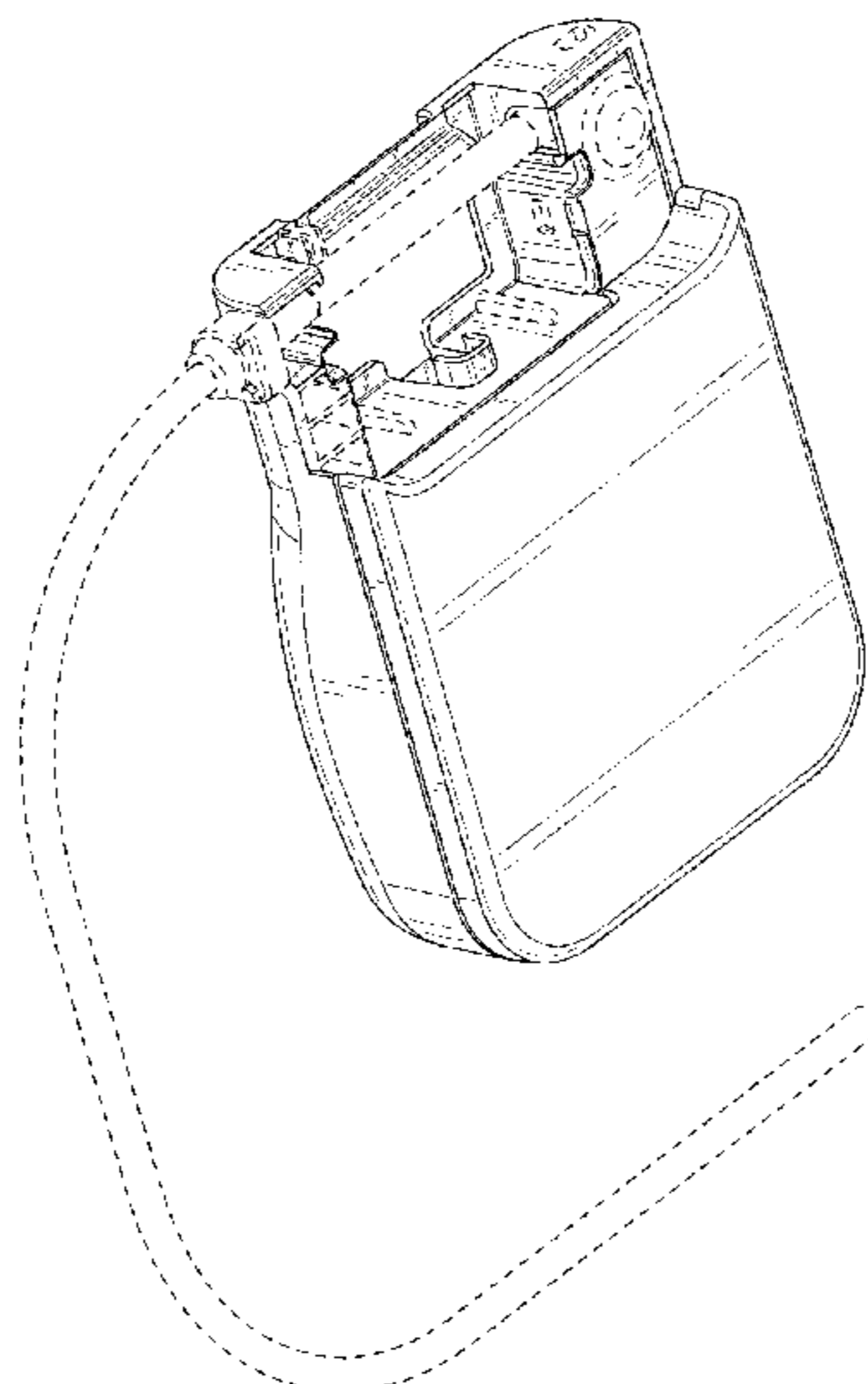

(56)

References Cited

U.S. PATENT DOCUMENTS

D471,562 S 3/2003 Kagami et al.  
 D471,917 S 3/2003 Kagami et al.  
 D482,370 S 11/2003 Niwatsukino et al.  
 D484,146 S 12/2003 Urano et al.  
 6,742,992 B2 6/2004 Davis  
 D517,091 S 3/2006 Sugiyama et al.  
 7,018,361 B2 3/2006 Gillespie, Jr. et al.  
 D520,023 S 5/2006 Goto et al.  
 D520,024 S 5/2006 Chen  
 D566,131 S 4/2008 Detering et al.  
 D579,569 S 10/2008 Strawn et al.  
 D583,856 S \* 12/2008 Mizuno ..... D18/12  
 D585,543 S 1/2009 Yodfat et al.  
 7,628,770 B2 12/2009 Ethelfeld  
 D626,647 S 11/2010 Amborn et al.  
 7,927,306 B2 4/2011 Cross et al.  
 8,114,066 B2 2/2012 Naef et al.  
 D655,810 S 3/2012 Amborn et al.  
 D659,717 S 5/2012 Mattson et al.  
 8,298,184 B2 10/2012 DiPerna et al.  
 D675,252 S \* 1/2013 Harvey ..... D18/56  
 8,377,002 B2 2/2013 Hanson et al.  
 D687,140 S 7/2013 Guarraia et al.  
 D689,523 S 9/2013 Galbraith et al.  
 D697,204 S 1/2014 Maier et al.  
 D720,804 S \* 1/2015 Van Den Broecke ..... D18/56  
 D725,678 S 3/2015 Sekula et al.  
 8,974,415 B2 3/2015 Robert et al.  
 D744,586 S \* 12/2015 Chung ..... D15/122  
 2003/0233069 A1 12/2003 Gillespie et al.  
 2004/0051368 A1 3/2004 Caputo et al.  
 2007/0078377 A1 4/2007 Mason  
 2008/0091139 A1 4/2008 Srinivasan et al.  
 2008/0255516 A1 10/2008 Yodfat et al.

2009/0182265 A1 7/2009 Mason  
 2010/0049128 A1 2/2010 McKenzie et al.  
 2010/0143168 A1 6/2010 Miyazaki et al.  
 2011/0202005 A1 8/2011 Yodfat et al.  
 2012/0053522 A1 3/2012 Yodfat et al.  
 2012/0191059 A1 7/2012 Cummings et al.  
 2012/0277667 A1 11/2012 Yodat et al.  
 2013/0267899 A1 10/2013 Robert et al.

OTHER PUBLICATIONS

U.S. Appl. No. 29/550,455, filed Jan. 4, 2016.  
 U.S. Appl. No. 29/513,434, Jul. 20, 2015 Notice of Allowance.  
 U.S. Appl. No. 29/513,434, Oct. 20, 2015 Issue Fee Payment.  
 U.S. Appl. No. 29/513,436, Aug. 24, 2015 Notice of Allowance.  
 U.S. Appl. No. 29/51,3438, Feb. 26, 2016 Notice of Allowance.  
 U.S. Appl. No. 29/513,434, filed Dec. 30, 2014.  
 U.S. Appl. No. 29/513,436, filed Dec. 30, 2014.  
 U.S. Appl. No. 29/513,437, filed Dec. 30, 2014.  
 U.S. Appl. No. 29/513,438, filed Dec. 30, 2014.  
 U.S. Appl. No. 14/586,912, filed Dec. 30, 2014.  
 U.S. Appl. No. 14/586,916, filed Dec. 30, 2014.  
 U.S. Appl. No. 29/513,436, Nov. 24, 2015 Issue Fee Payment.  
 U.S. Appl. No. 29/513,438, Feb. 26, 2016 Notice of Allowance.  
 U.S. Appl. No. 29/513,436, Nov. 24, 2015 Issue Fee Payment.  
 U.S. Appl. No. 29/566,784, Sep. 16, 2016 Notice of Allowance.  
 U.S. Appl. No. 29/566,784, filed Jun. 2, 2016.  
 U.S. Appl. No. 29/513,437, Sep. 9, 2016 Notice of Allowance.  
 U.S. Appl. No. 29/513,437, Aug. 18, 2016 Response to Non-Final Office Action.  
 U.S. Appl. No. 29/513,437, May 20, 2016 Non-Final Office Action.  
 U.S. Appl. No. 29/513,438, Jun. 28, 2016 Notice of Allowance.  
 U.S. Appl. No. 29/513,438, May 26, 2016 Notice of Allowance.  
 U.S. Appl. No. 29/513,438, May 26, 2016 Issue Fee Payment.

\* cited by examiner

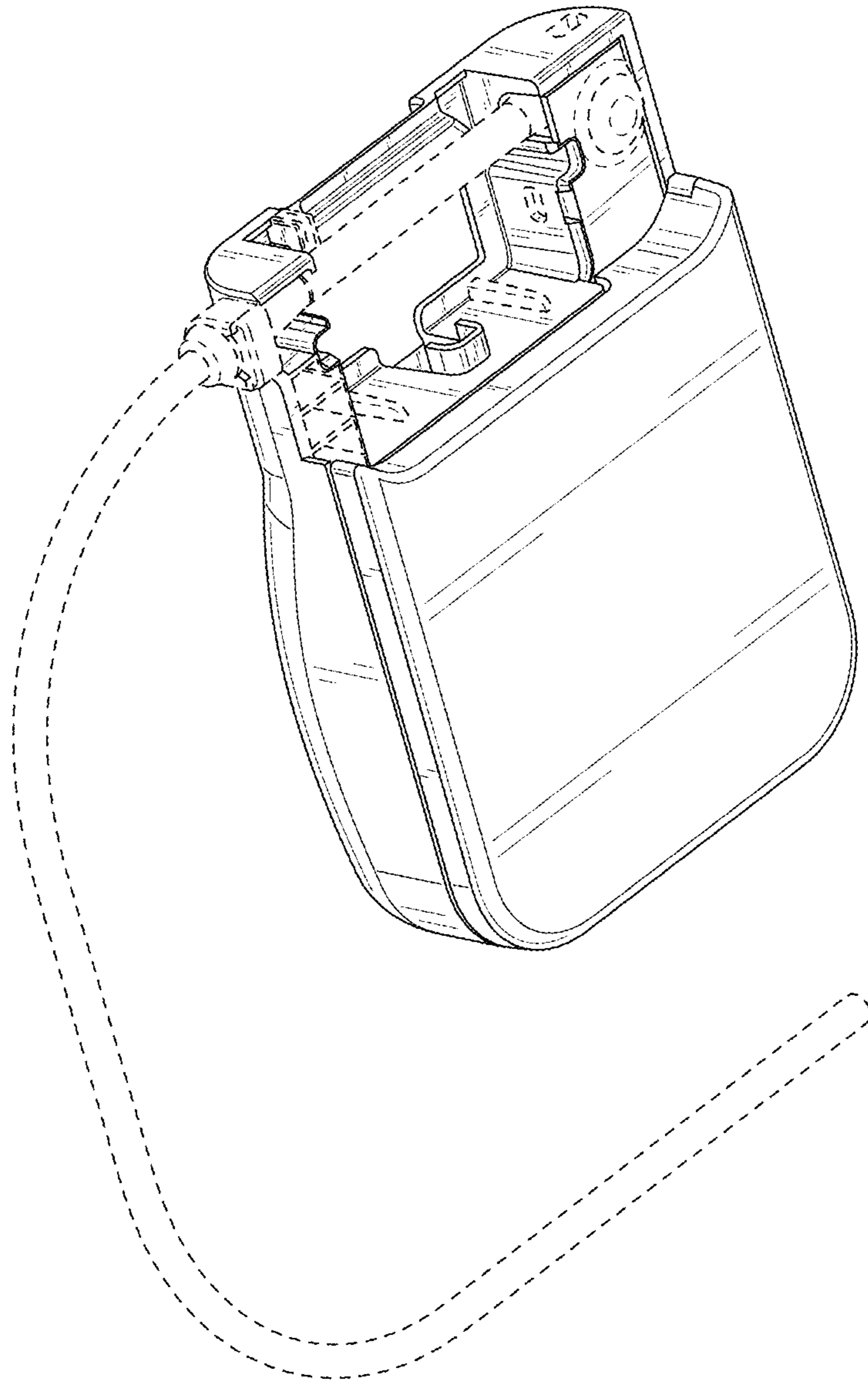

FIG. 1

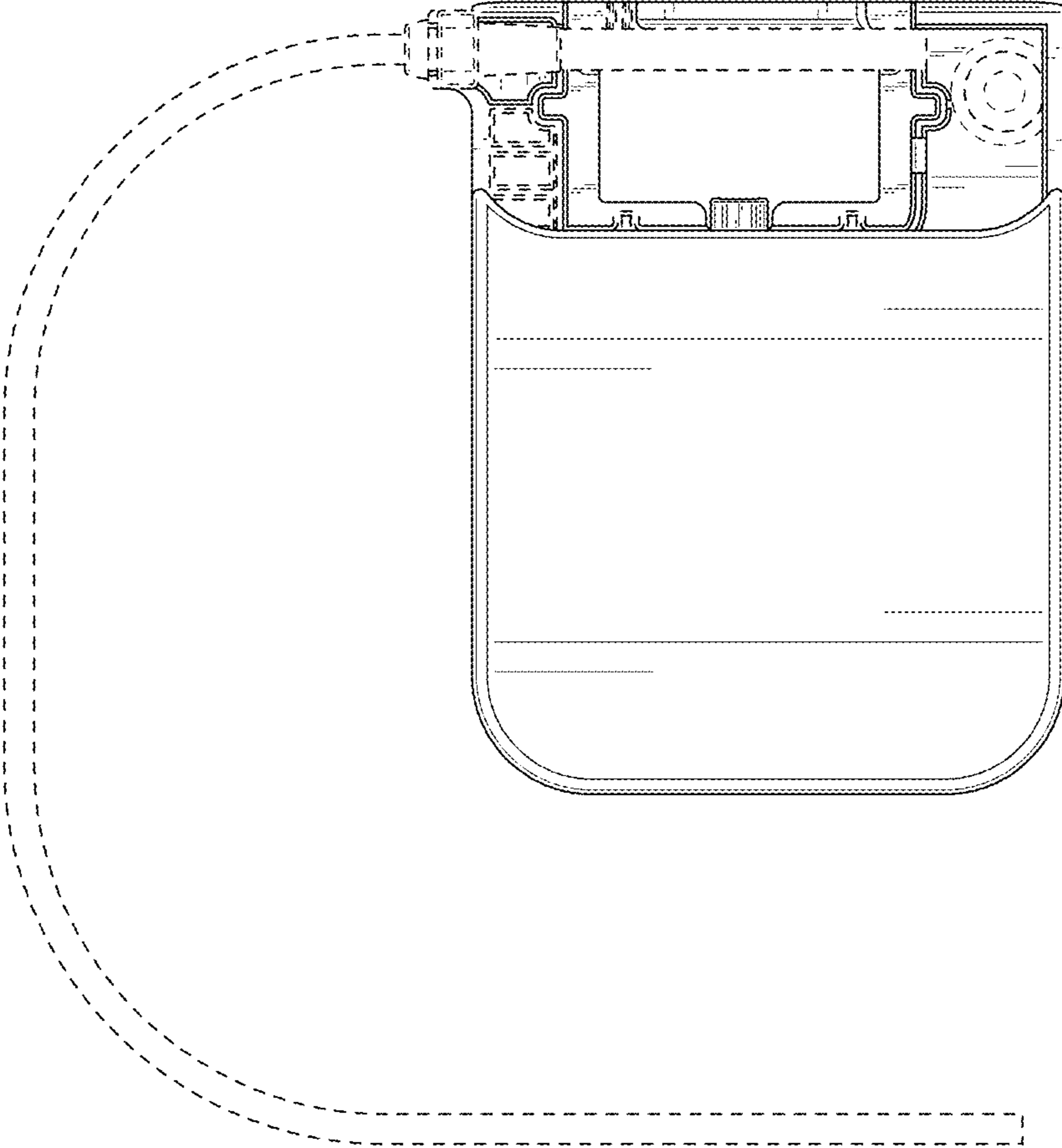

FIG. 2

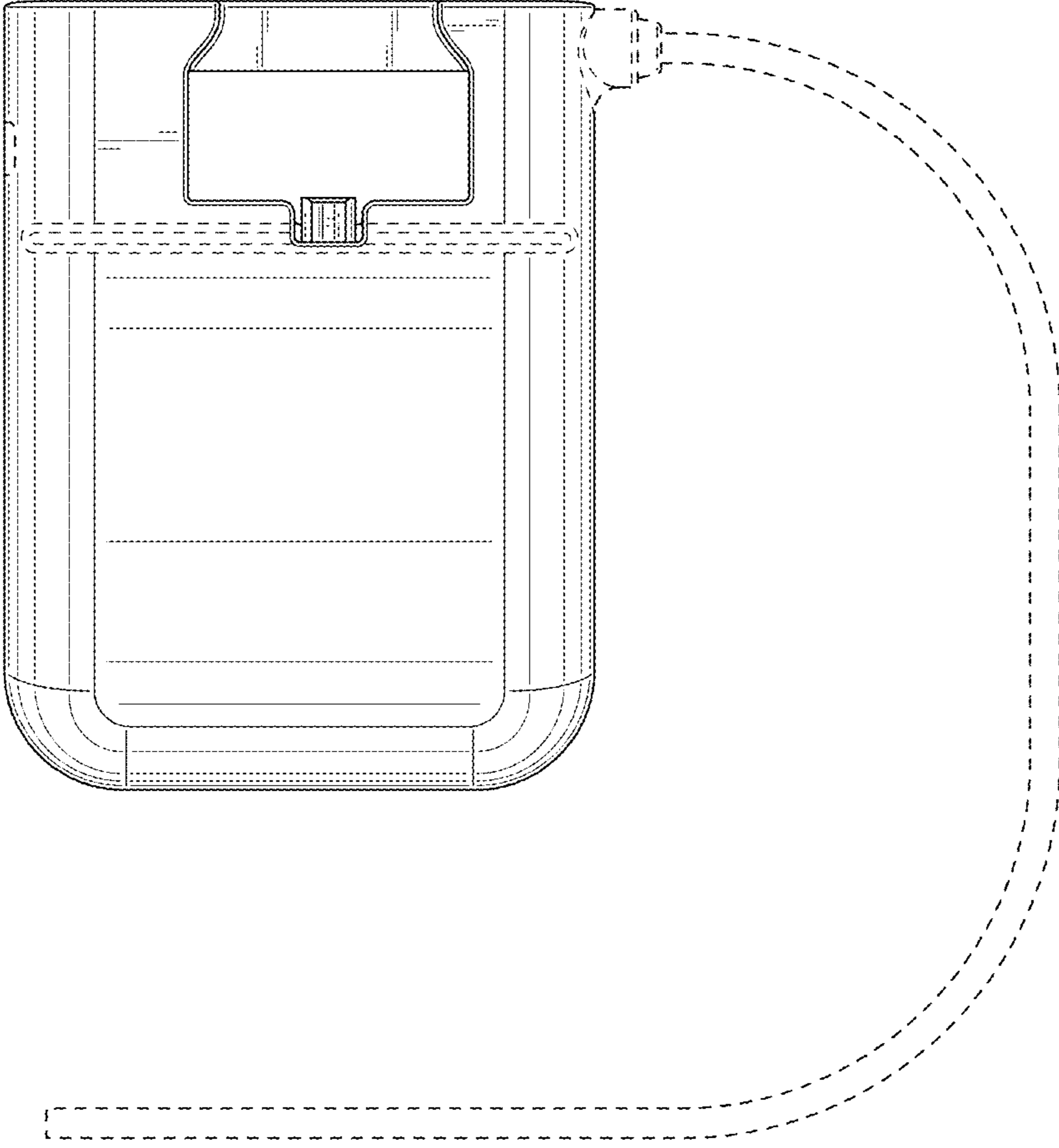

FIG. 3

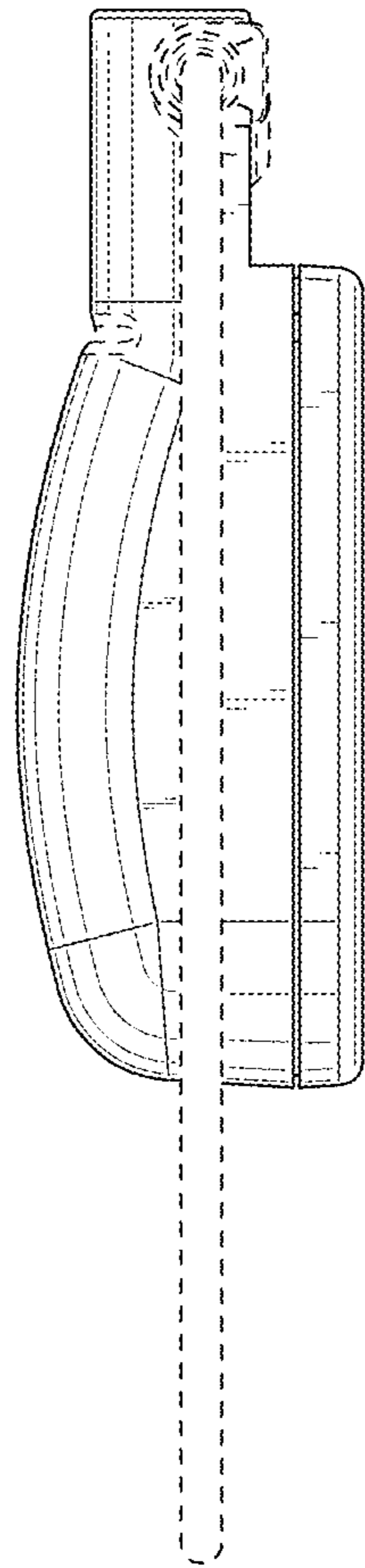

FIG. 4

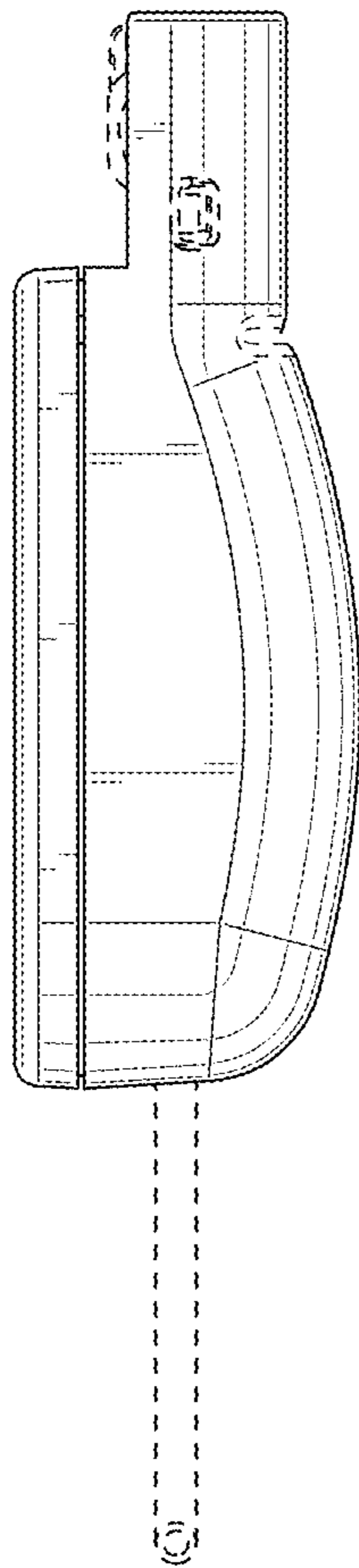

FIG. 5

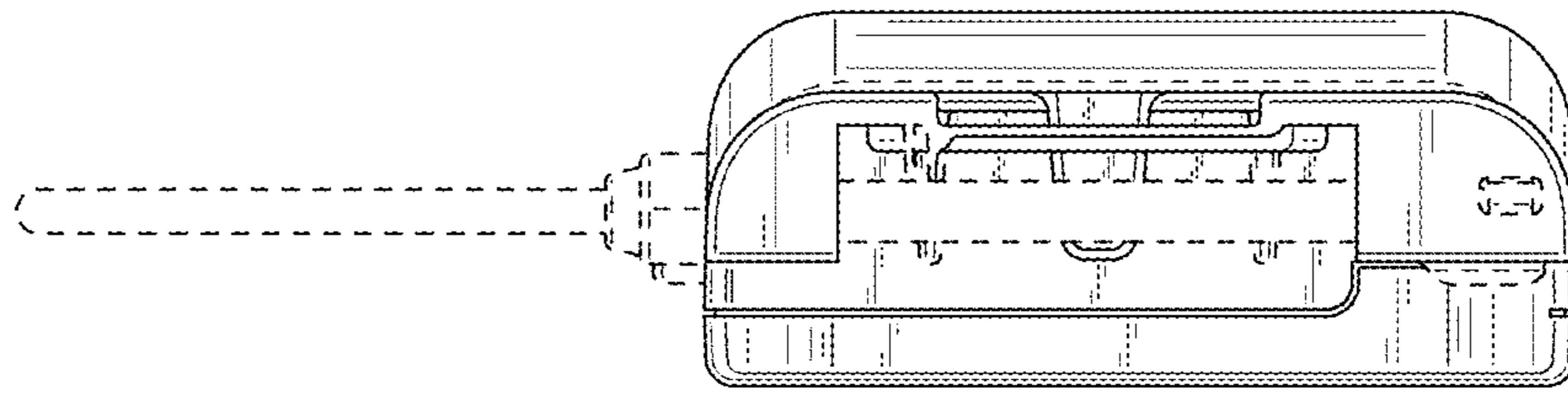

FIG. 6

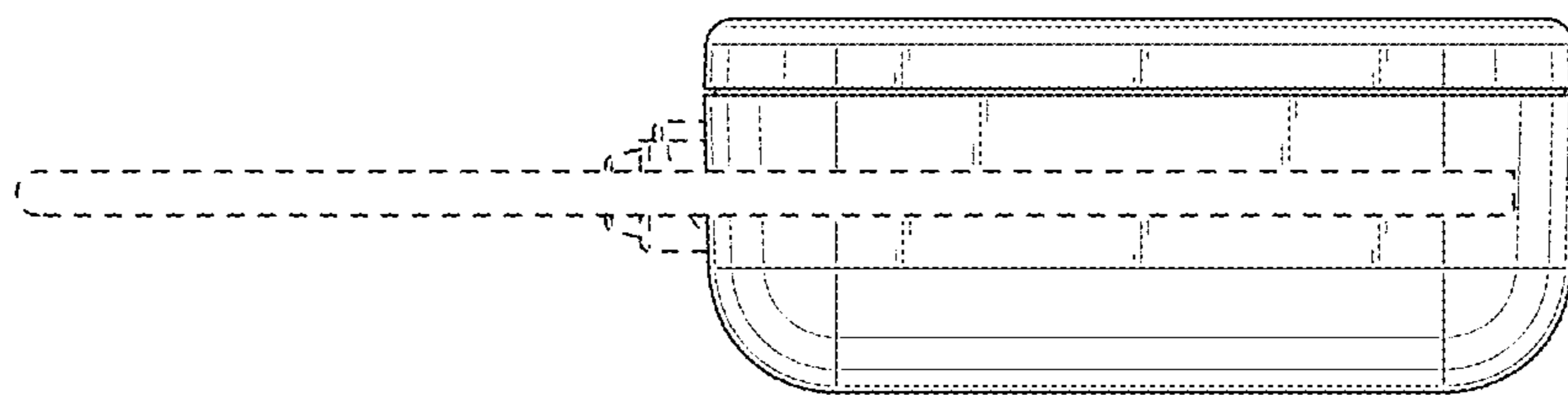

FIG. 7