



US00D777291S

(12) **United States Design Patent** (10) **Patent No.:** **US D777,291 S**  
**Seaton** (45) **Date of Patent:** **\*\* Jan. 24, 2017**

- (54) **INSECT TRAP HOUSING**
- (71) Applicant: **Dynamic Solutions Worldwide, LLC**,  
Milwaukee, WI (US)
- (72) Inventor: **Robert Seaton**, Verona, WI (US)
- (73) Assignee: **Dynamic Solutions Worldwide, LLC**,  
Milwaukee, WI (US)
- (\*\*) Term: **15 Years**
- (21) Appl. No.: **29/528,317**
- (22) Filed: **May 28, 2015**
- (51) **LOC (10) Cl.** ..... **22-06**
- (52) **U.S. Cl.**  
USPC ..... **D22/122**
- (58) **Field of Classification Search**  
USPC ..... D22/119–124; 43/112–113, 139  
CPC ..... A01M 1/08; A01M 1/023; A01M 1/04  
See application file for complete search history.

- D532,479 S \* 11/2006 Child ..... D22/122  
D590,041 S \* 4/2009 Schneidmiller ..... D22/122  
D678,457 S \* 3/2013 English, II ..... D22/122  
D733,253 S \* 6/2015 Oehlschlager ..... D22/122  
2014/0137462 A1 5/2014 Rocha  
2014/0165452 A1 6/2014 Rocha

\* cited by examiner

*Primary Examiner* — Catheri Oliver-Garcia  
(74) *Attorney, Agent, or Firm* — Boyle Fredrickson, S.C.

(57) **CLAIM**

The ornamental design for an insect trap housing, substantially as shown and described.

**DESCRIPTION**

FIG. 1 is a bottom, front and right side isometric view of the insect trap housing according to the present invention;  
FIG. 2 is a top, front and left side isometric view of the insect trap housing of FIG. 1;  
FIG. 3 is a top and rear isometric view of the insect trap housing of FIG. 1;  
FIG. 4 is a top plan view of the insect trap housing of FIG. 1; and,  
FIG. 5 is a bottom plan view of the insect trap housing of FIG. 1.

The broken lines are for illustrative purposes and represent environmental structure and unclaimed portions of the invention and therefore form no part of the claimed design.

**1 Claim, 5 Drawing Sheets**

- (56) **References Cited**
- U.S. PATENT DOCUMENTS
- 4,282,673 A 8/1981 Focks et al.  
D366,688 S \* 1/1996 Carvalho ..... D22/122  
5,515,643 A \* 5/1996 Lin ..... A01M 1/04  
43/112  
D524,902 S \* 7/2006 Masters ..... D22/122

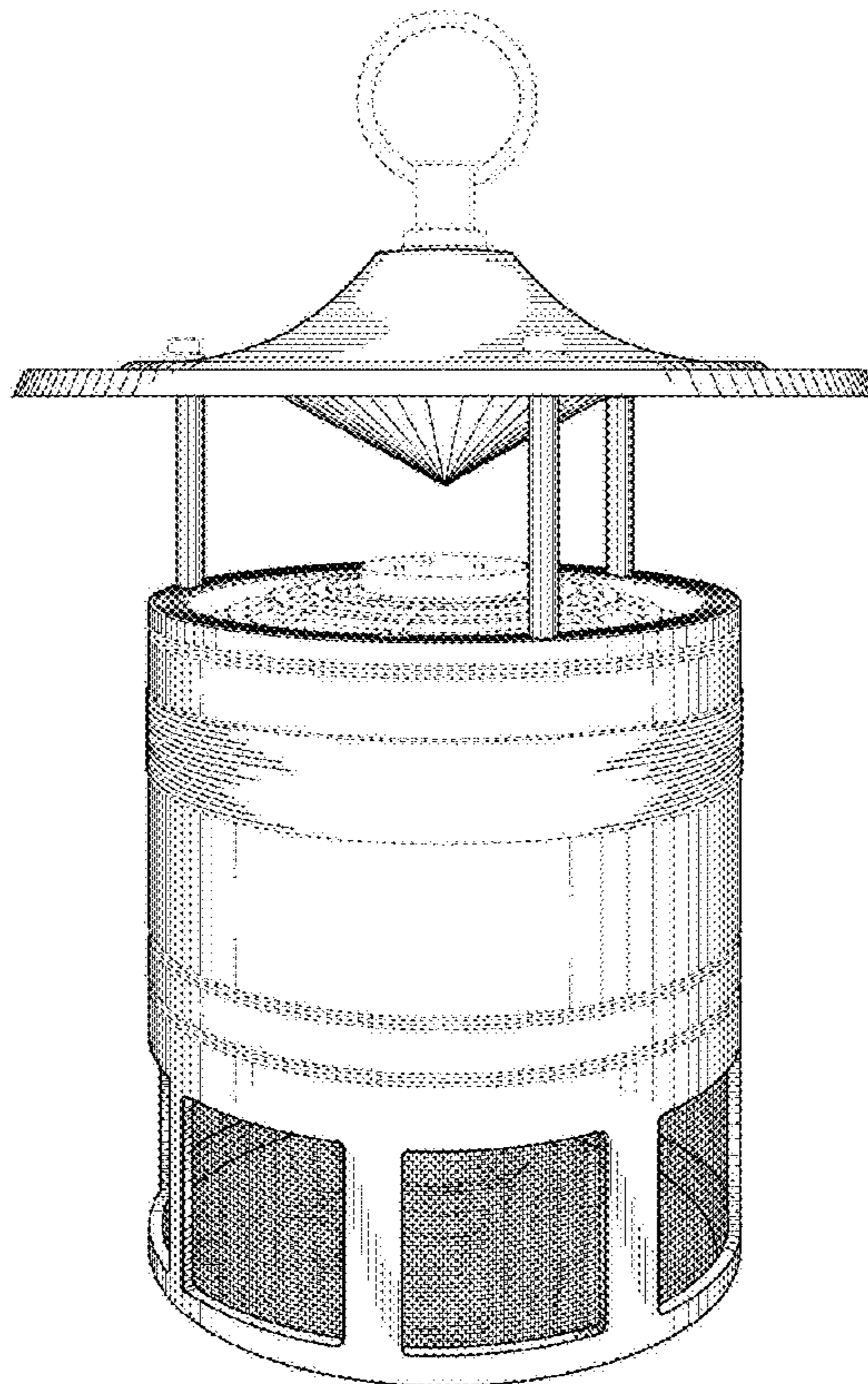

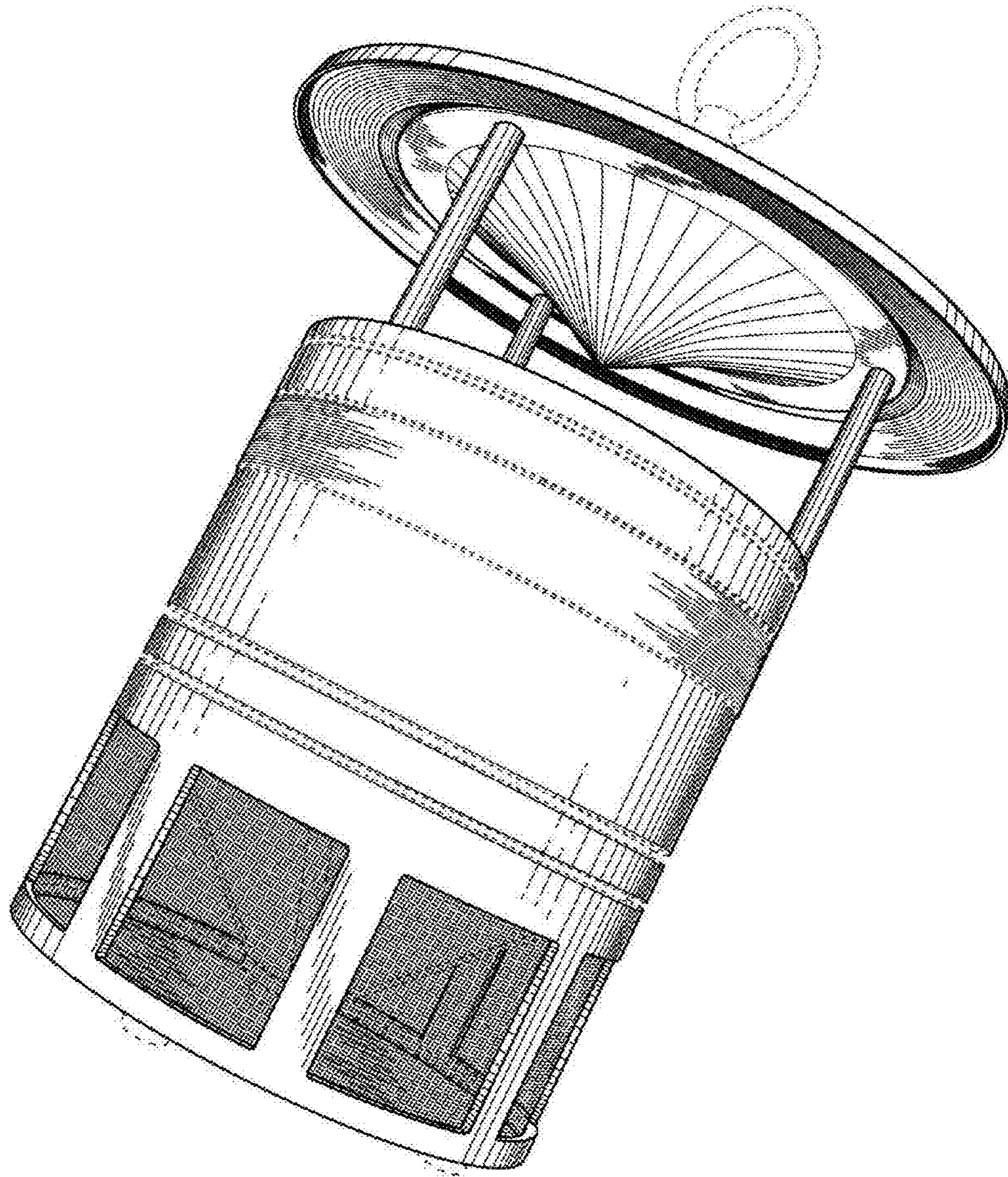

FIG. 1

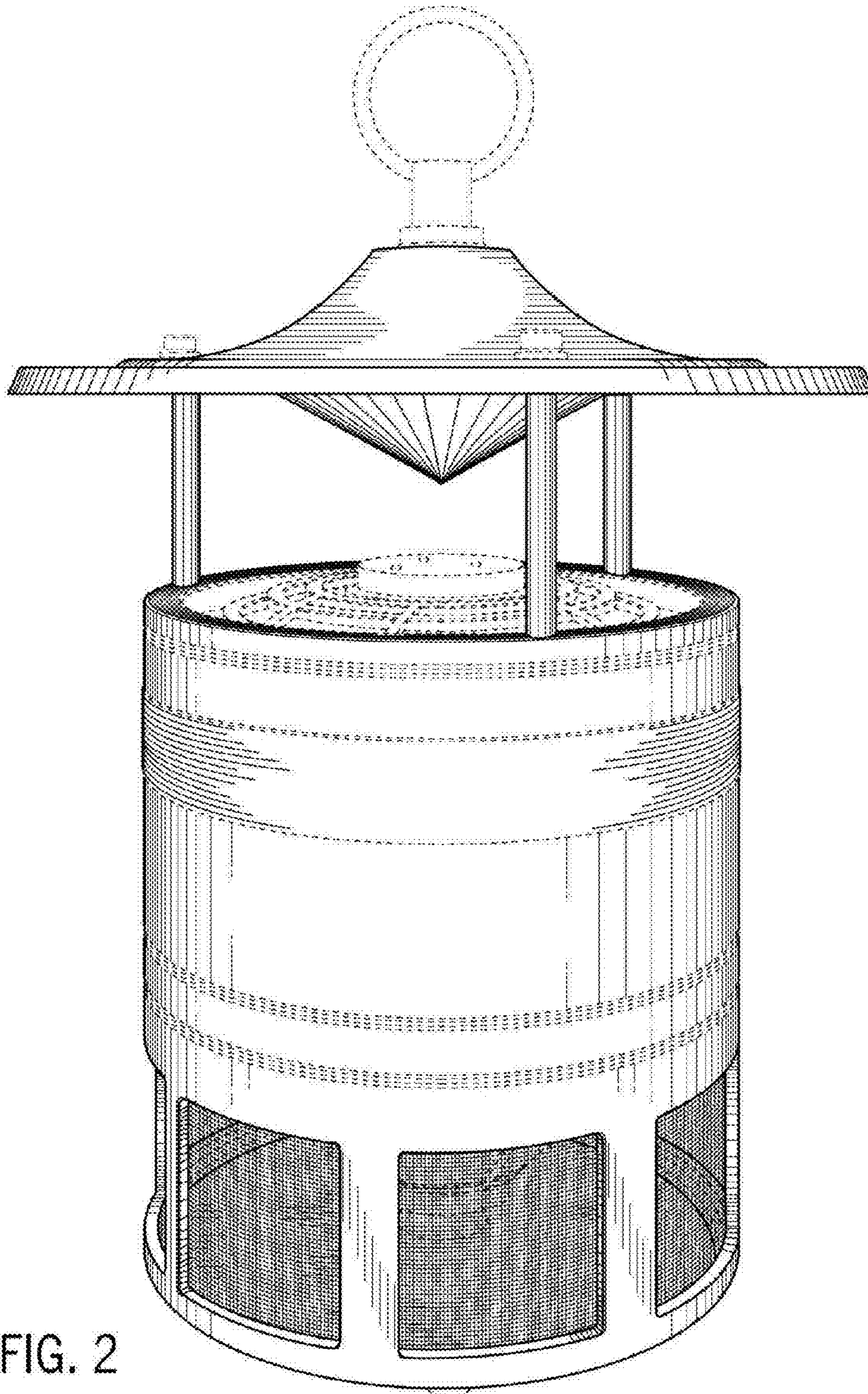

FIG. 2

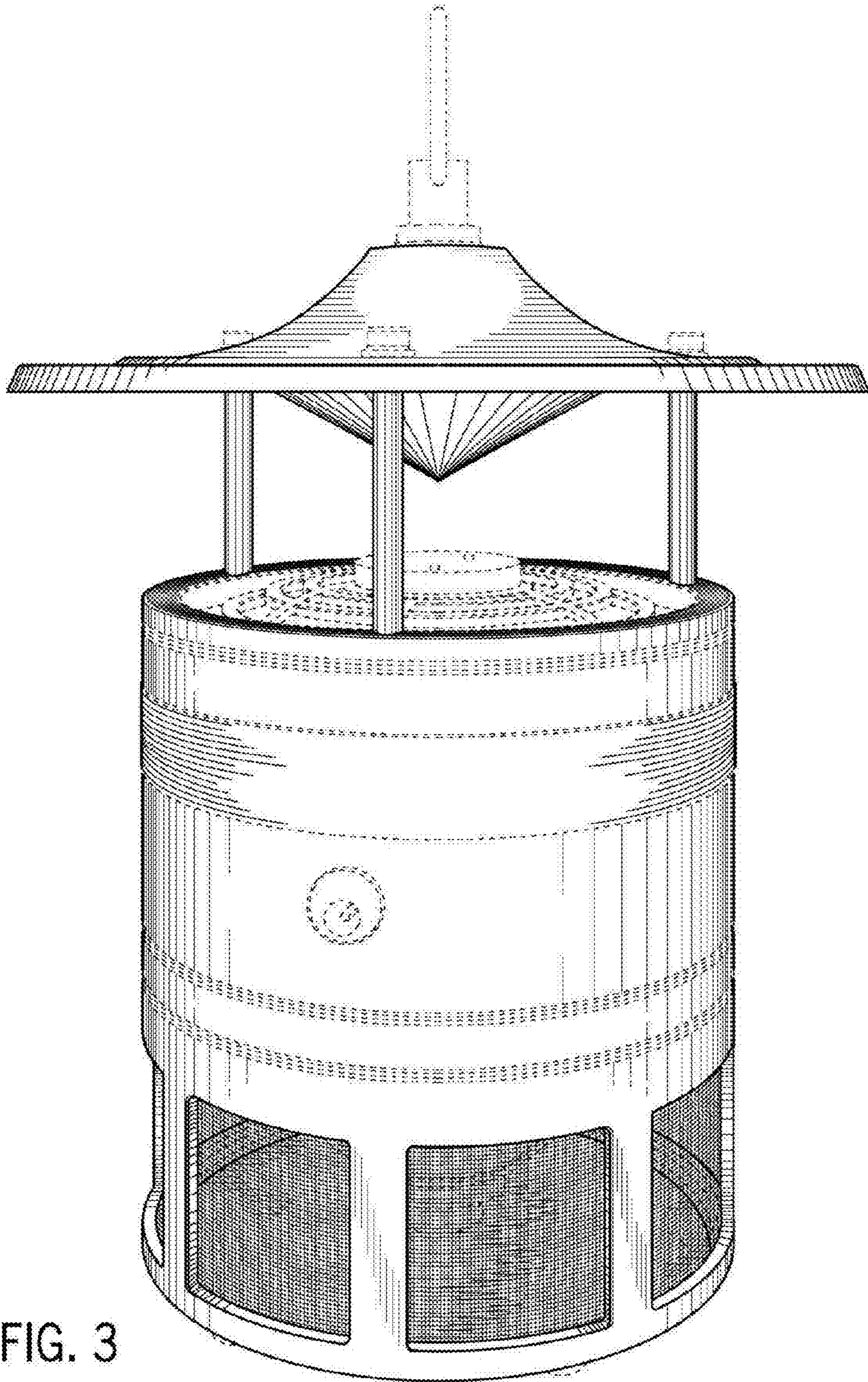

FIG. 3

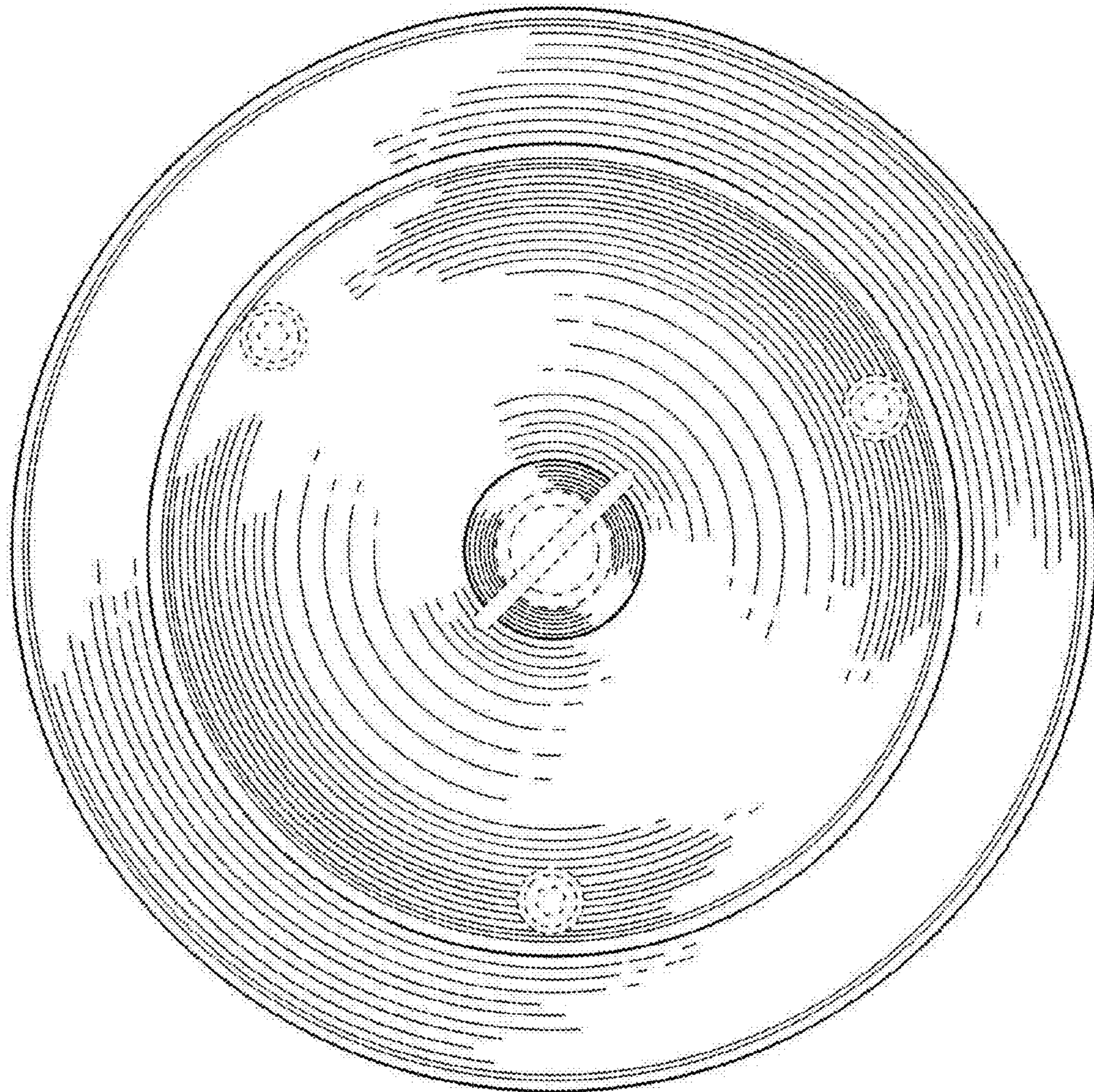

FIG. 4

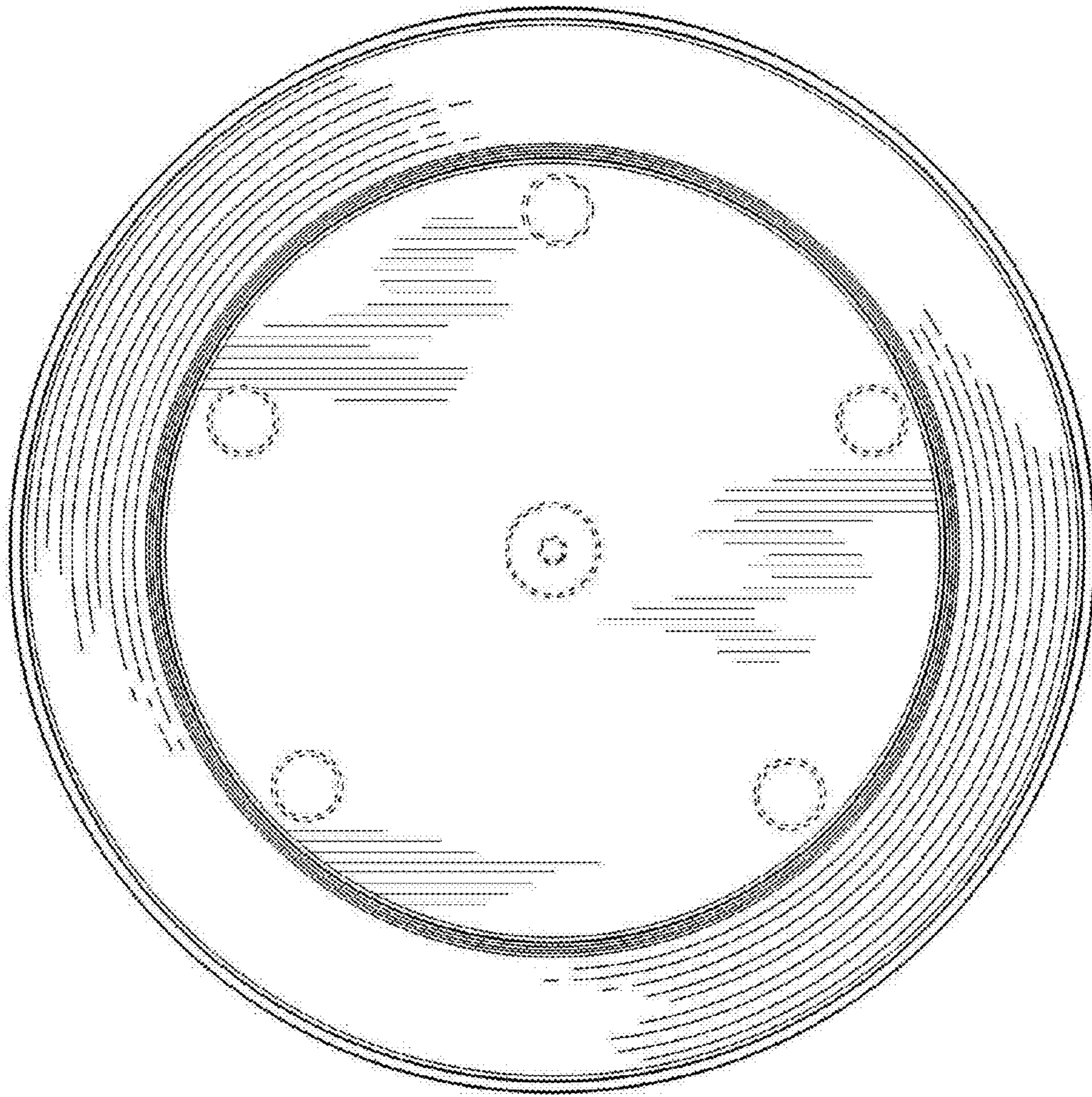

FIG. 5