



US00D777218S

(12) **United States Design Patent**
Harms et al.

(10) **Patent No.:** **US D777,218 S**

(45) **Date of Patent:** **** Jan. 24, 2017**

(54) **OPERATOR COMPARTMENT AND ENGINE HOUSING**

(71) Applicant: **Clark Equipment Company**, West Fargo, ND (US)

(72) Inventors: **Jeremy A. Harms**, Bismarck, ND (US); **James M. Breuer**, Mandan, ND (US); **Michael D. Wetzel**, Bismarck, ND (US); **Shawn M. Bauer**, Bismarck, ND (US); **Jinhup Yeu**, Yongin (KR)

(73) Assignee: **Clark Equipment Company**, West Fargo, ND (US)

(**) Term: **15 Years**

(21) Appl. No.: **29/539,079**

(22) Filed: **Sep. 10, 2015**

(51) **LOC (10) Cl.** **12-09**

(52) **U.S. Cl.**
USPC **D15/30**

(58) **Field of Classification Search**
USPC .. D15/10, 11, 15, 17, 22, 23, 25, 26, 28, 30
CPC E02F 9/0841; E02F 3/3411; E02F 3/76;
E02F 3/34; E02F 3/00; E02F 7/00; E02F 9/16; E02F 9/163; B66C 13/54; B60J 7/00; B60J 1/004; B62D 33/0617; B62D 49/00; B62D 49/0815; B62D 21/186; B62D 53/028

See application file for complete search history.

(56) **References Cited**

U.S. PATENT DOCUMENTS

D258,823 S *	4/1981	Skyer	D15/30
D297,329 S *	8/1988	Monehaie	D15/30
D312,827 S *	12/1990	Boddin	D15/30
D505,432 S *	5/2005	Antonetti	D15/30

D531,647 S *	11/2006	Stender	D15/30
D577,040 S *	9/2008	Kim	D15/30
D594,036 S *	6/2009	Iwakata	D15/30
D594,480 S *	6/2009	Gicquel	D15/30
D605,207 S *	12/2009	Menges	D15/30
D637,630 S *	5/2011	Yamamoto	D15/30
D642,205 S *	7/2011	Yamamoto	D15/30
D648,357 S *	11/2011	Hagele	D15/27
D674,411 S *	1/2013	Masumoto	D15/30
D678,360 S *	3/2013	Kozai	D15/30
D705,276 S *	5/2014	Furuki	D15/30
D707,728 S *	6/2014	Imashige	D15/30
D734,369 S *	7/2015	Miller	D15/30
D742,940 S *	11/2015	Kushita	D15/30
D748,156 S *	1/2016	Koponen	D15/30

(Continued)

Primary Examiner — Ian Simmons

Assistant Examiner — Khawaja Anwar

(74) *Attorney, Agent, or Firm* — Michael Best & Friedrich LLP

(57) **CLAIM**

We claim the ornamental design for an operator compartment and engine housing, as shown and described.

DESCRIPTION

FIG. 1 is a perspective view of an operator compartment and engine housing, showing our new design;
FIG. 2 is a right side view thereof;
FIG. 3 is a left side view thereof;
FIG. 4 is a front side view thereof;
FIG. 5 is a rear view thereof; and,
FIG. 6 is a top view thereof.

The broken lines immediately adjacent the shaded areas represent the bounds of the claimed design while all other broken lines are directed to environment and are for illustrative purposes only; the broken lines form no part of the claimed design.

1 Claim, 6 Drawing Sheets

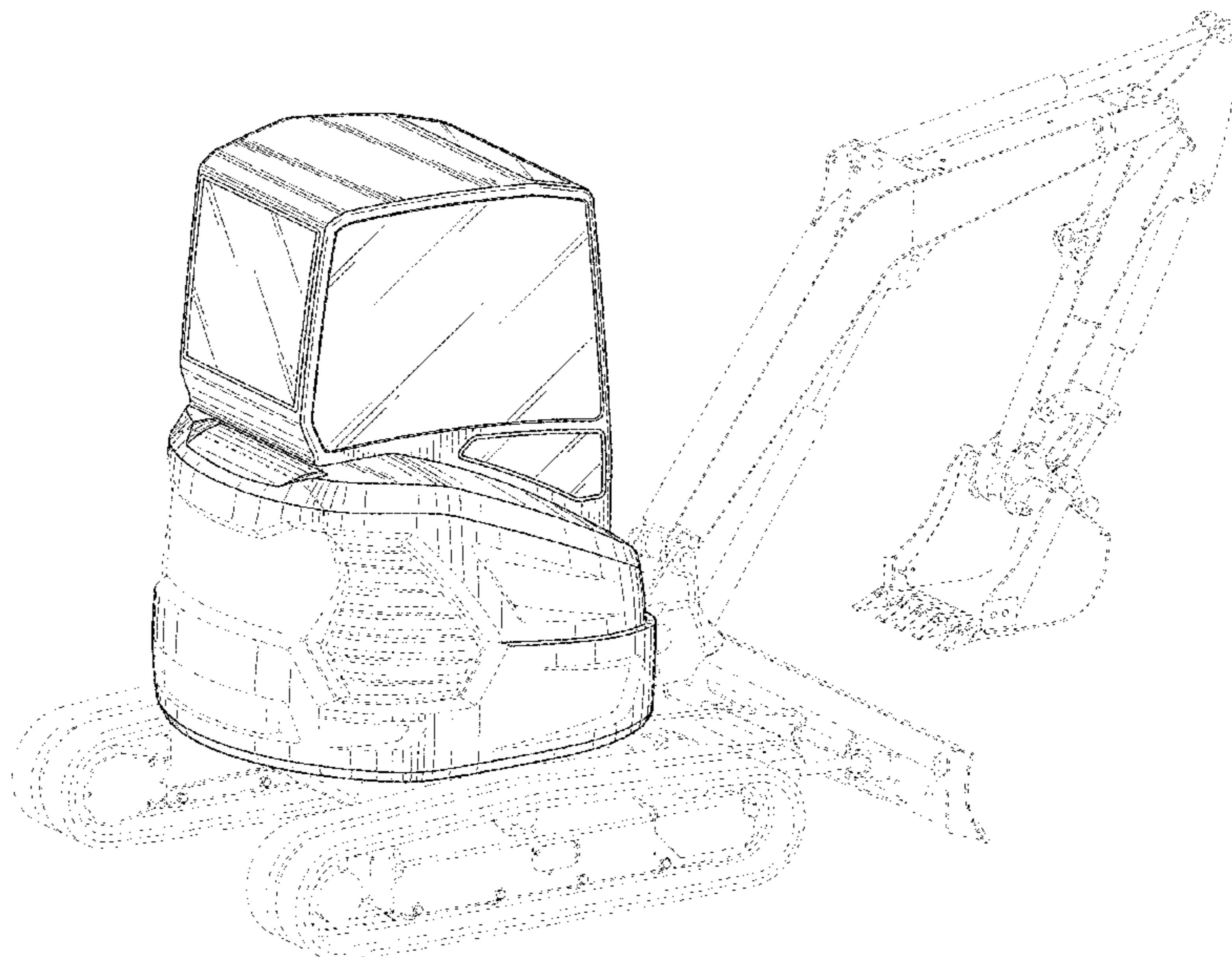

(56)

References Cited

U.S. PATENT DOCUMENTS

D749,149 S *	2/2016	McAdam	D15/30
D749,649 S *	2/2016	McAdam	D15/30
D751,123 S *	3/2016	Kzakoff	D15/30
D754,213 S *	4/2016	Okuyama	D15/30
D762,248 S *	7/2016	Steinhardt	D15/30

* cited by examiner

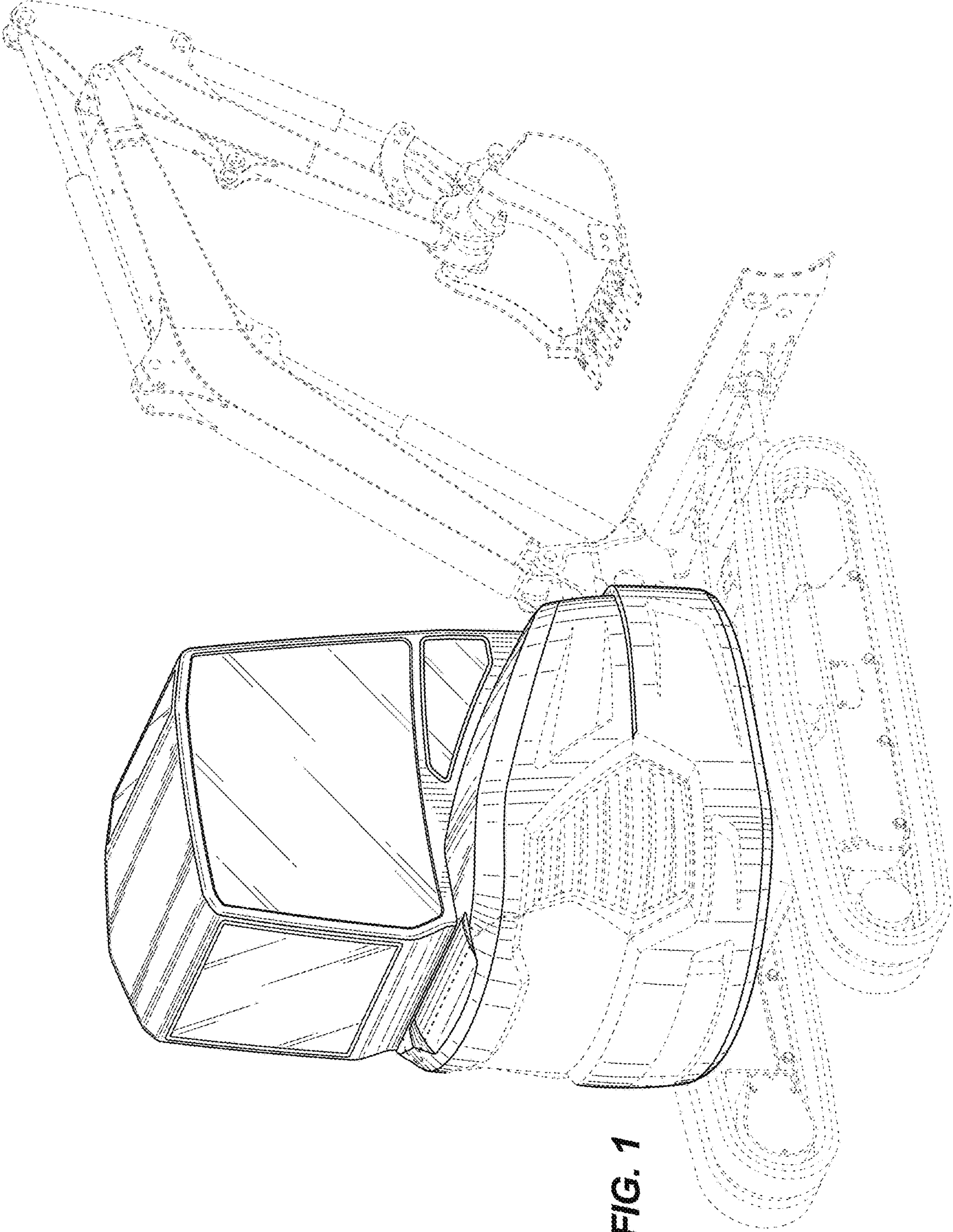

FIG. 1

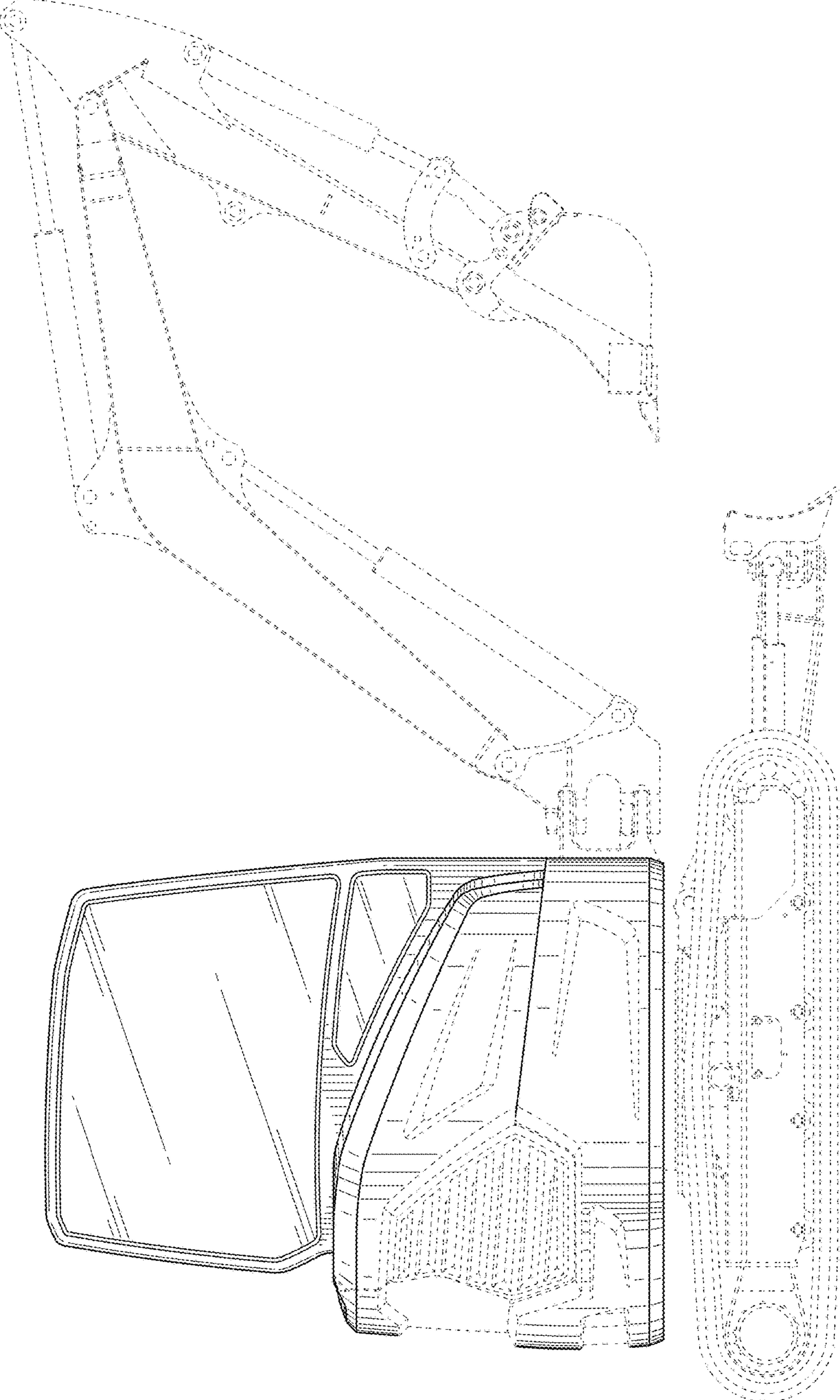
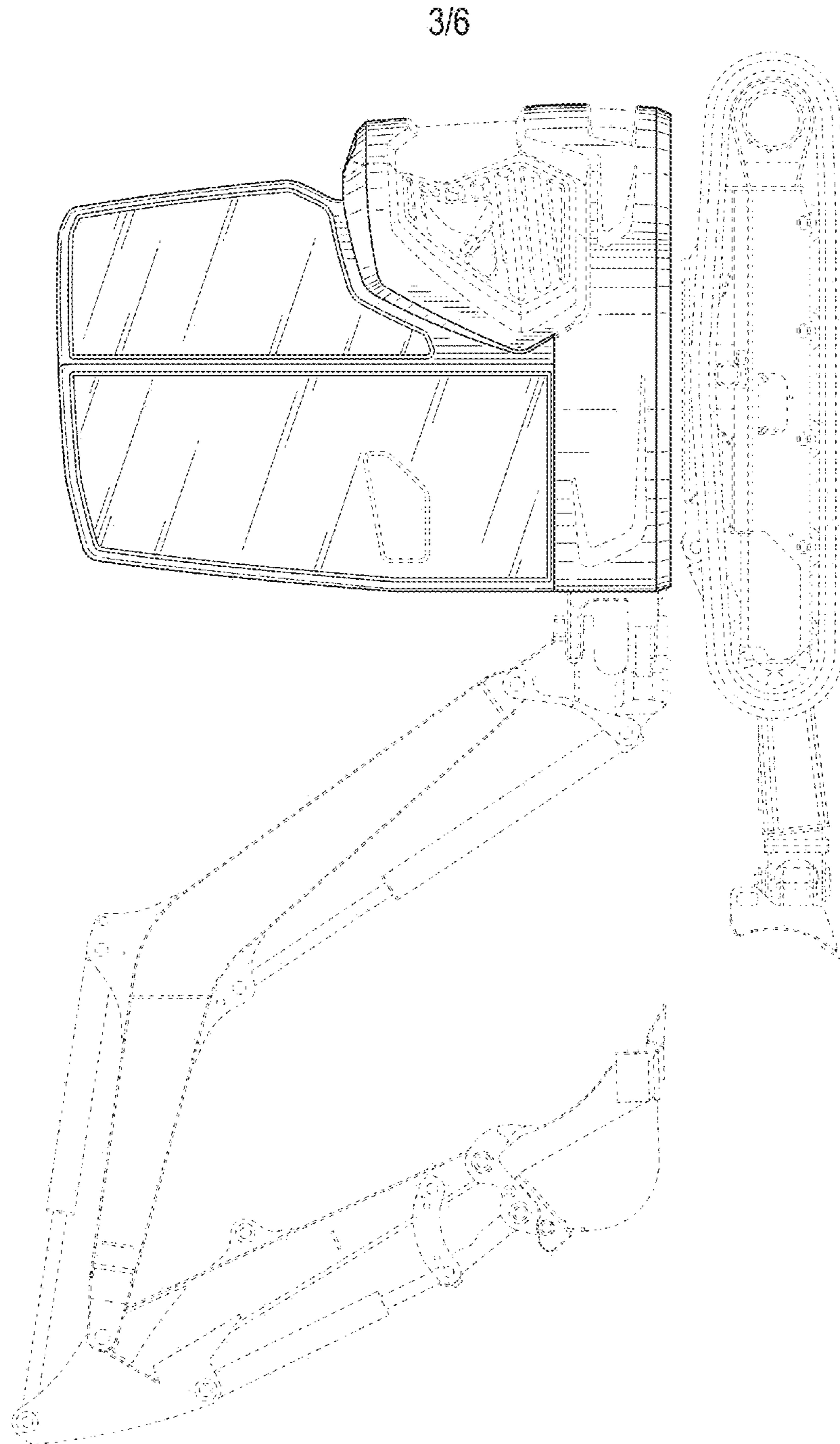

FIG. 2



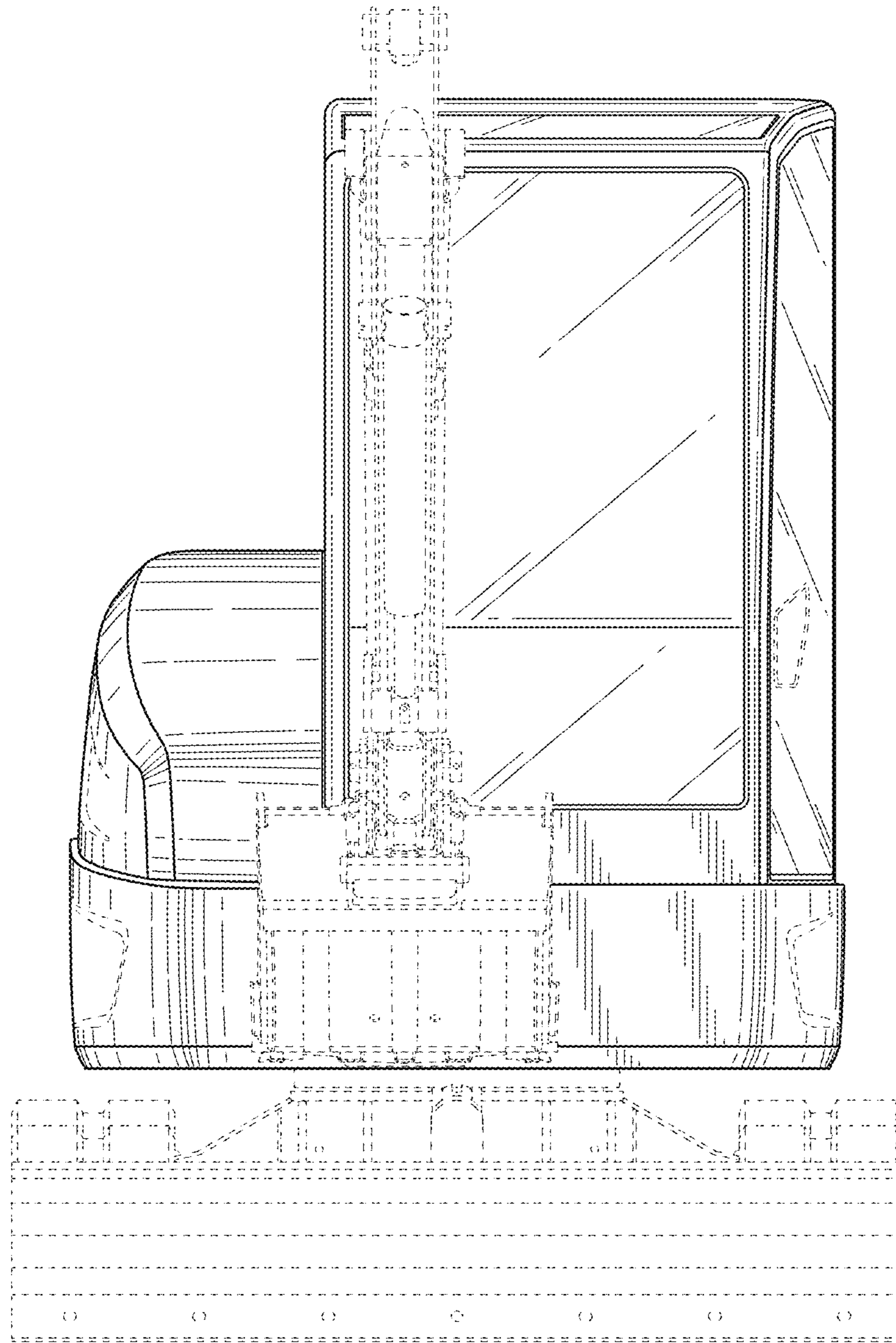

FIG. 4

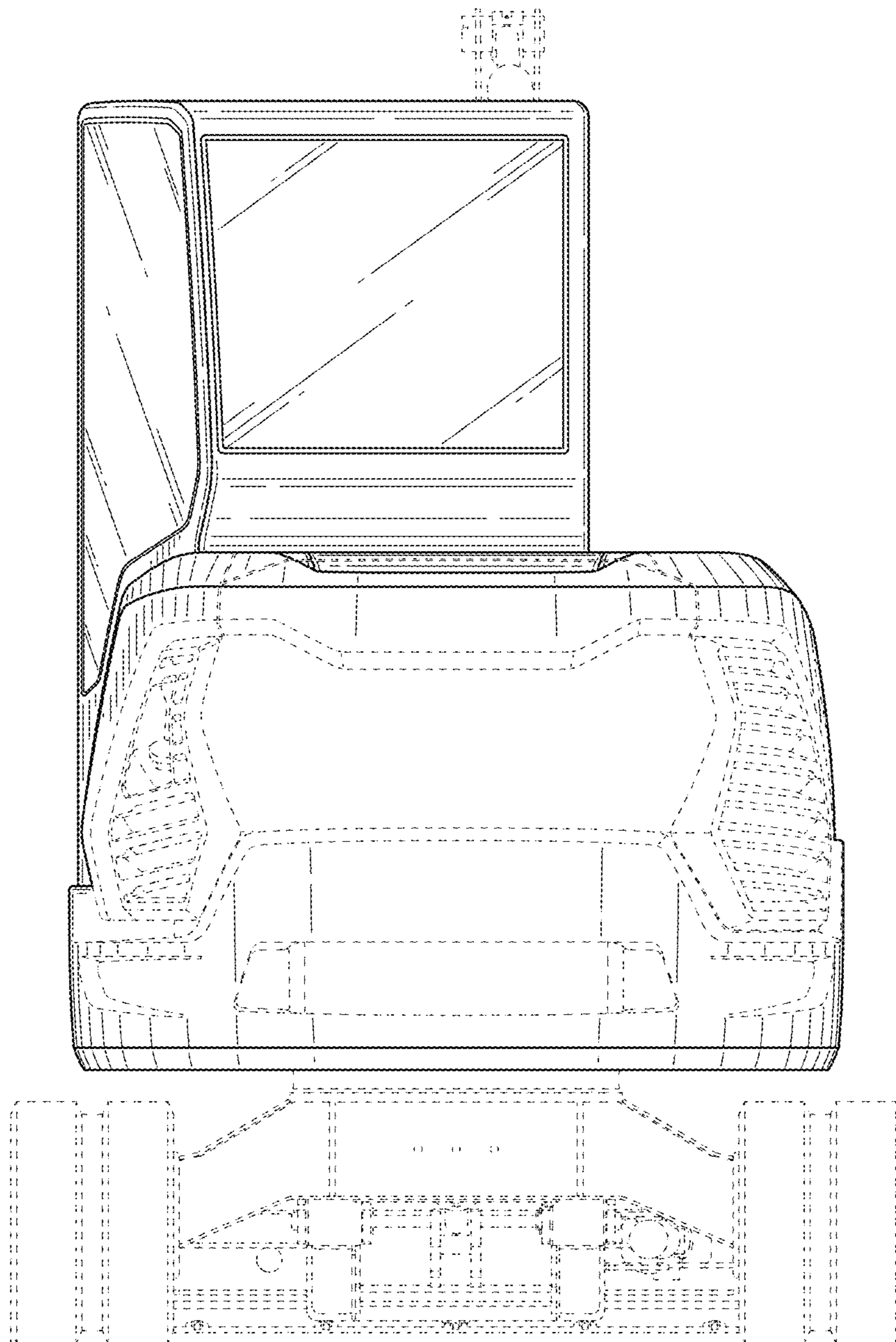

FIG. 5

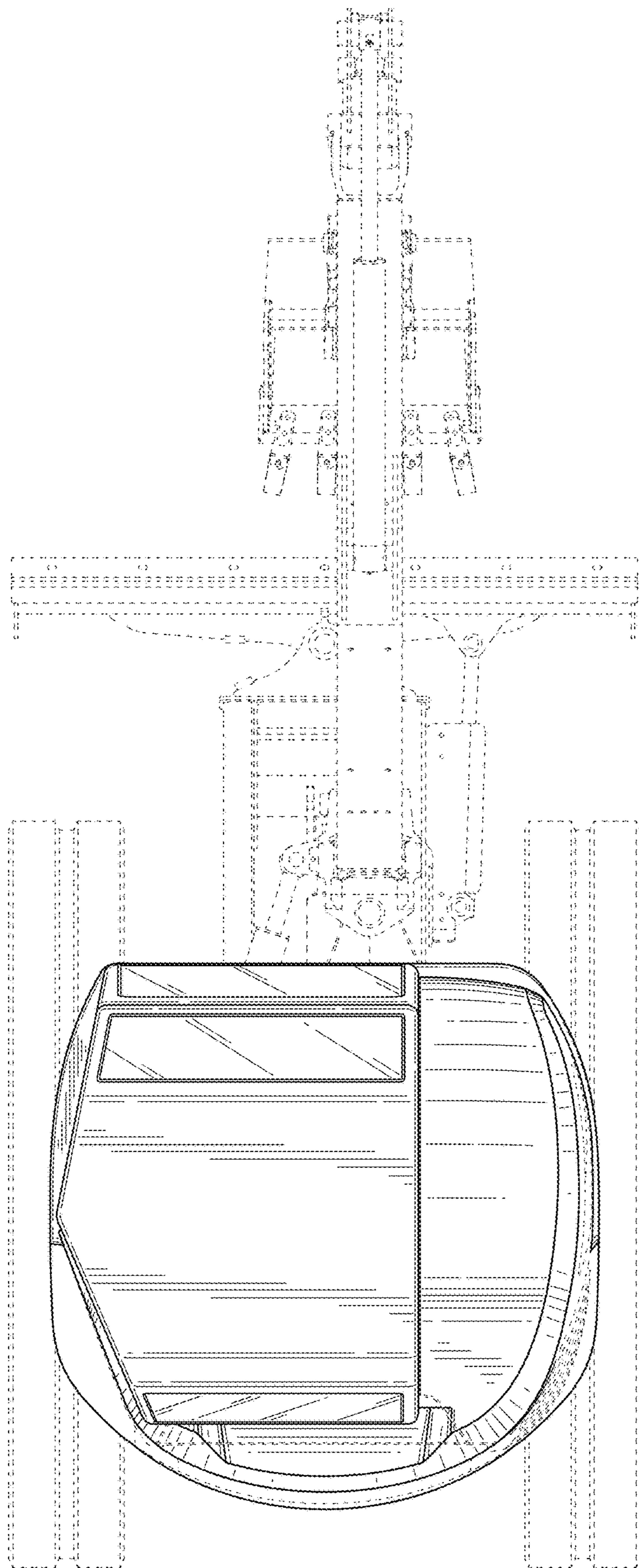

FIG. 6