



US00D777094S

(12) **United States Design Patent**
Takahashi

(10) **Patent No.:** **US D777,094 S**

(45) **Date of Patent:** **** Jan. 24, 2017**

- (54) **TIRE**
- (71) Applicant: **TOYO TIRE & RUBBER CO., LTD.**,
Osaka (JP)
- (72) Inventor: **Toshihiko Takahashi**, Osaka (JP)
- (73) Assignee: **TOYO TIRE & RUBBER CO., LTD.**,
Osaka (JP)
- (**) Term: **14 Years**
- (21) Appl. No.: **29/509,059**
- (22) Filed: **Nov. 13, 2014**

- D670,644 S * 11/2012 Miyazaki D12/605
- D674,744 S * 1/2013 Miyazaki D12/605
- D674,745 S * 1/2013 Miyazaki D12/605
- D689,815 S * 9/2013 Kuwano D12/605
- D695,211 S * 12/2013 Yasunaga D12/605
- D707,621 S * 6/2014 Tokizaki D12/605
- D754,596 S * 4/2016 Tokizaki D12/605

* cited by examiner

Primary Examiner — Robert M Spear
Assistant Examiner — Darcey E Heflin
(74) *Attorney, Agent, or Firm* — Sterne, Kessler,
Goldstein & Fox P.L.L.C.

(30) **Foreign Application Priority Data**

- Jun. 25, 2014 (JP) 2014-013859
- (51) **LOC (10) Cl.** **12-15**
- (52) **U.S. Cl.**
USPC **D12/605**
- (58) **Field of Classification Search**
USPC .. D7/396.4, 396.5, 588; D11/3, 4; D12/500,
D12/503, 506, 605; 152/209.8,
152/209.12, 517, 523, 524, DIG. 12
CPC B60C 13/00
See application file for complete search history.

(56) **References Cited**

U.S. PATENT DOCUMENTS

- D386,455 S * 11/1997 Clementz D12/605
- D412,476 S * 8/1999 Clementz D12/605
- D593,487 S * 6/2009 Takahashi D12/605
- D606,933 S 12/2009 Palma et al.
- D608,273 S * 1/2010 Scheifele D12/605
- D610,979 S 3/2010 Maxwell et al.
- D668,210 S * 10/2012 Sato D12/605

(57) **CLAIM**

The ornamental design for a tire, as shown and described.

DESCRIPTION

FIG. 1 is a perspective view of a tire showing the claimed design;
 FIG. 2 is a front view thereof;
 FIG. 3 is a rear view thereof;
 FIG. 4 is a top plan view thereof, the bottom plan view being a mirror image;
 FIG. 5 is a left side view thereof, the right side view being a mirror image;
 FIG. 6 is an enlarged view taken along lines 6-6 and 6'-6' in FIG. 2;
 FIG. 7 is an enlarged cross-sectional view taken along line 7-7 in FIG. 6;
 FIG. 8 is another enlarged view taken along lines 6-6 and 6'-6' in FIG. 2; and,
 FIG. 9 is an enlarged cross-sectional view taken along line 9-9 in FIG. 8.
 In the drawings, the broken lines showing portions of the tire tread, sidewall, and inner bead depict portions of the tire that form no part of the claimed design.

1 Claim, 9 Drawing Sheets

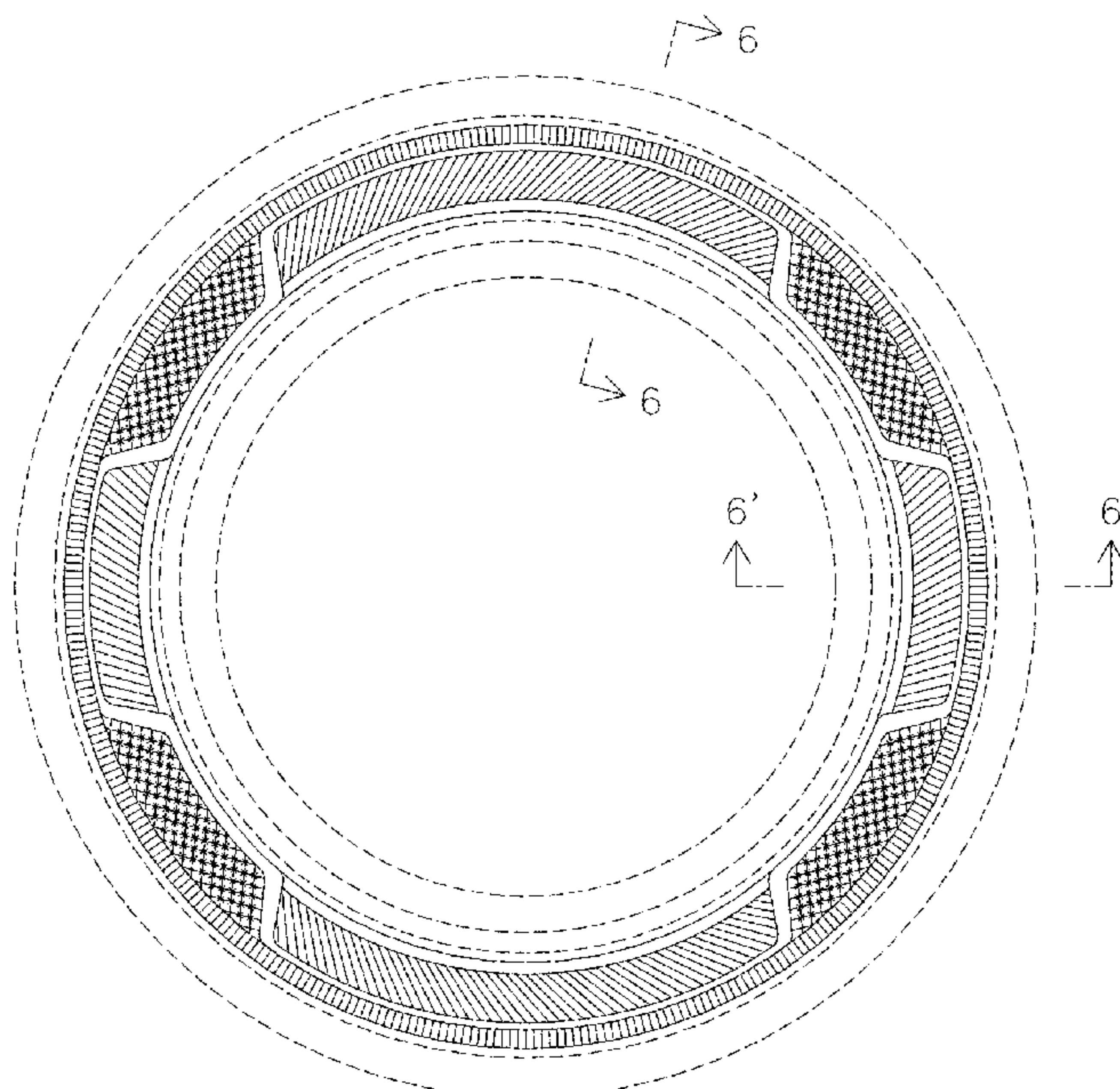

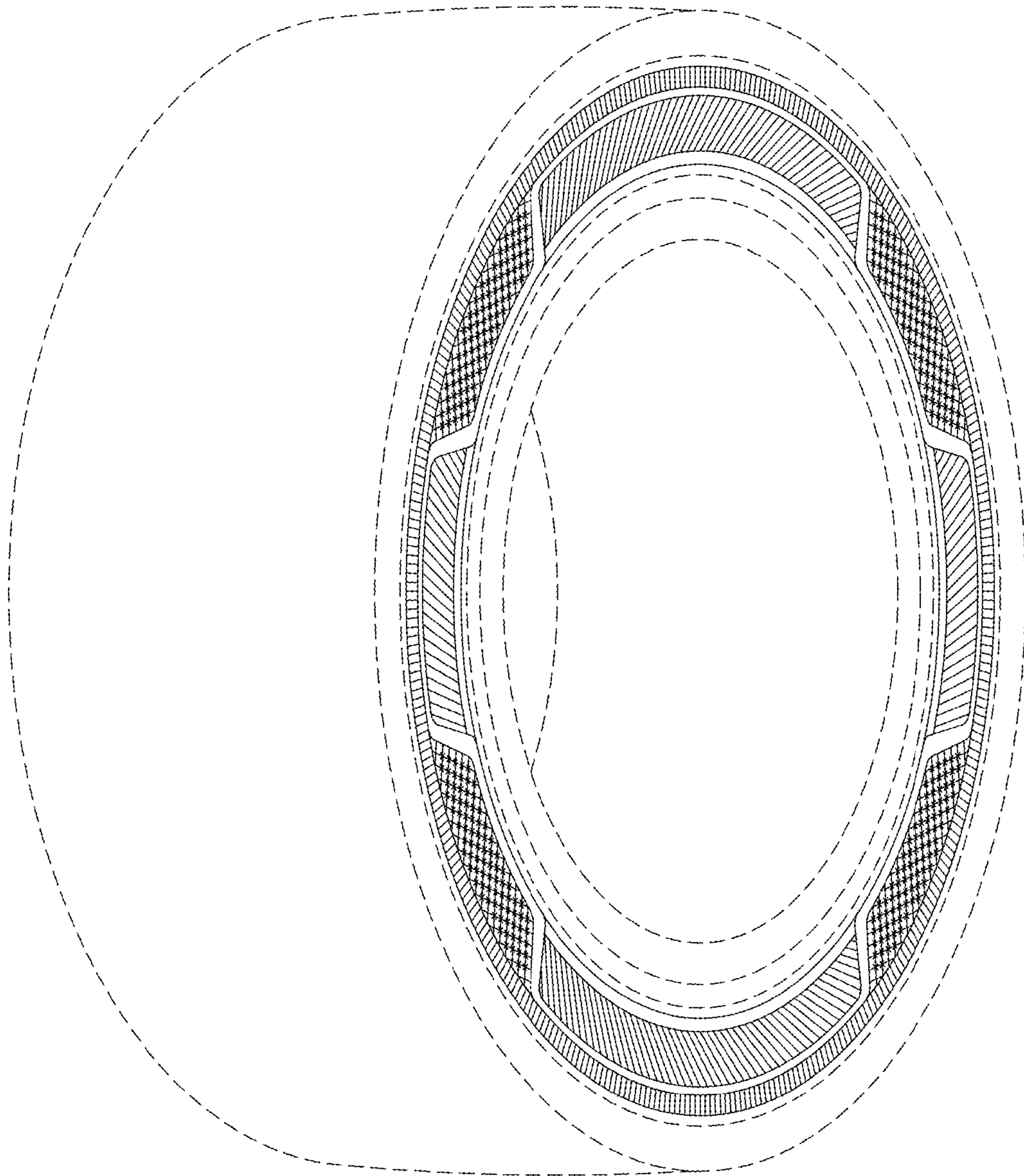

FIG. 1

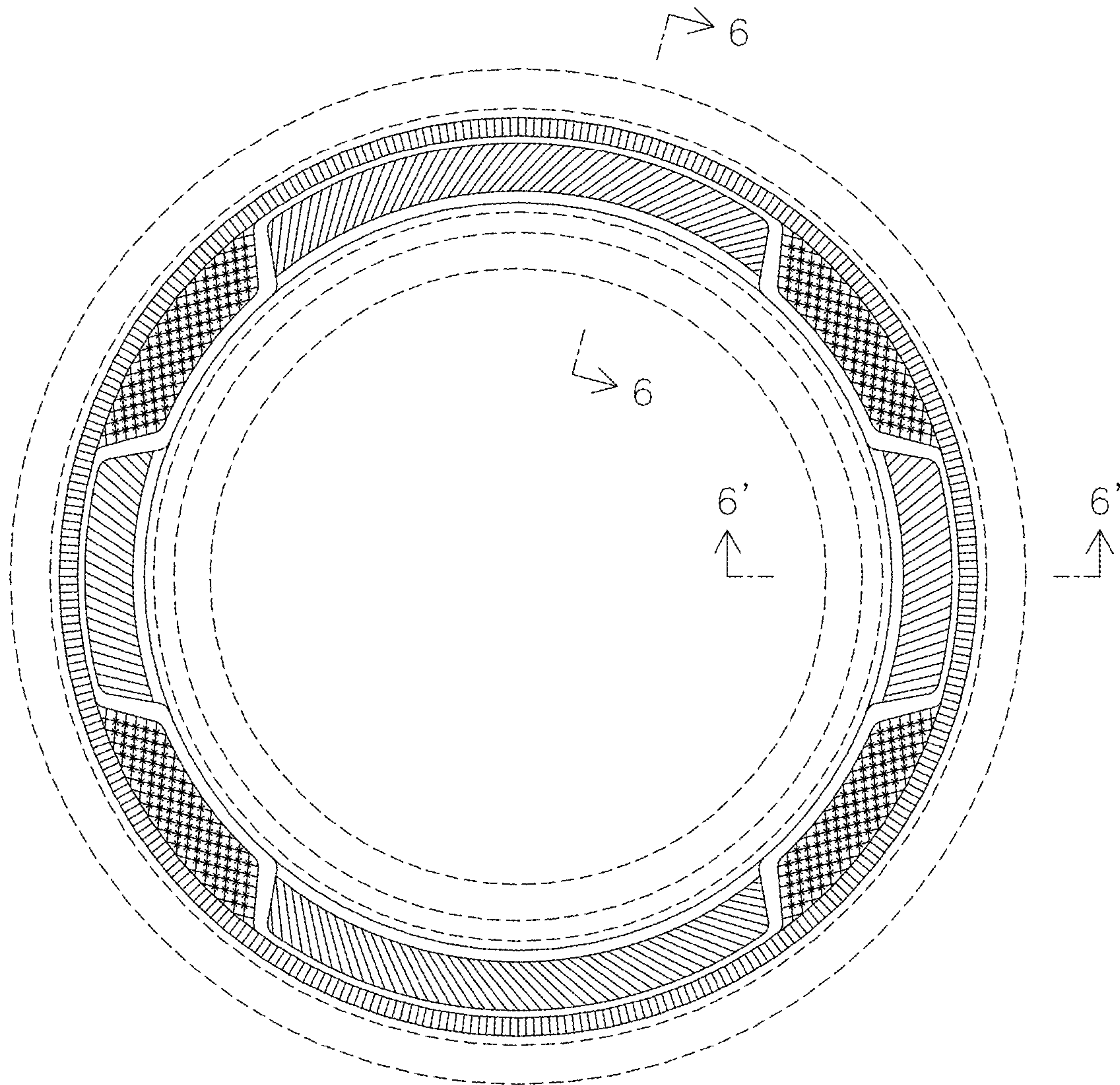

FIG. 2

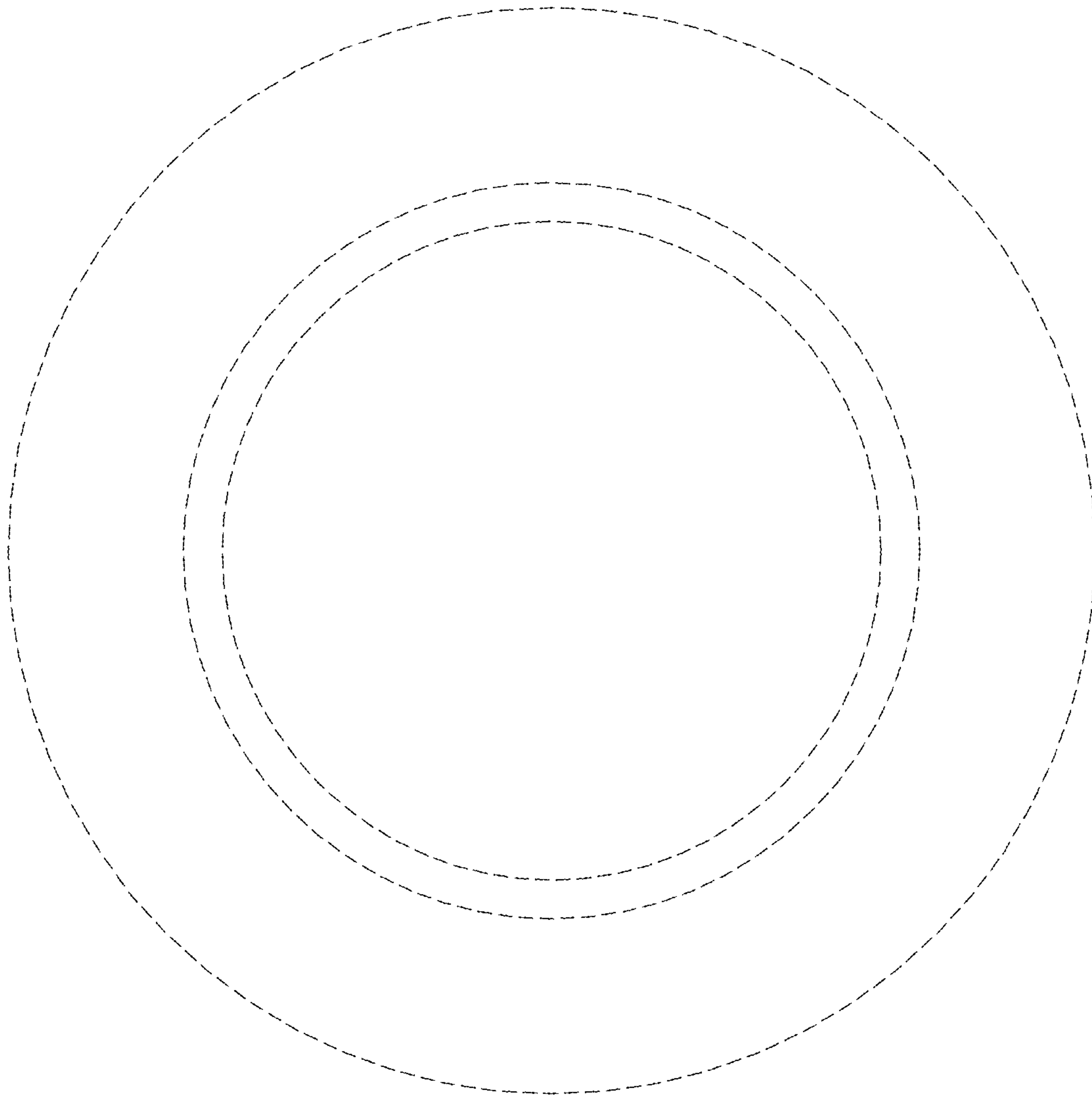

FIG. 3

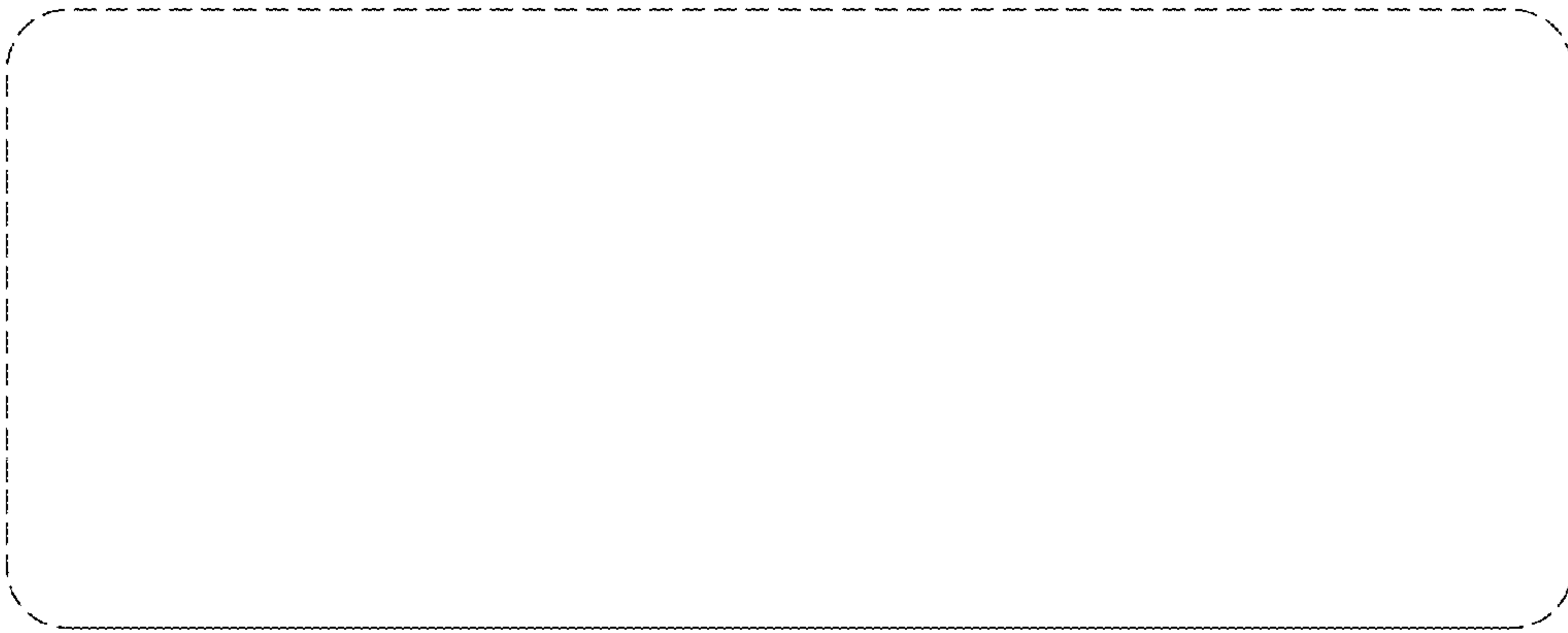

FIG. 4

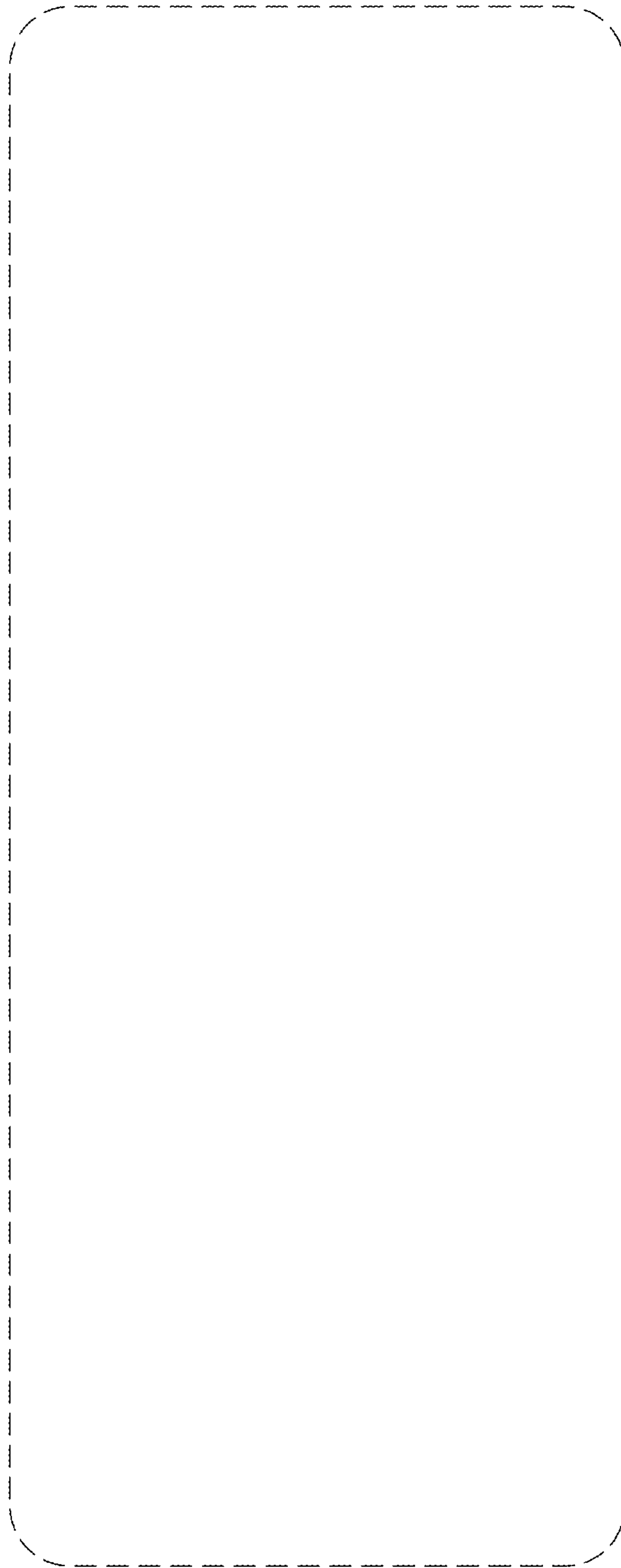

FIG. 5

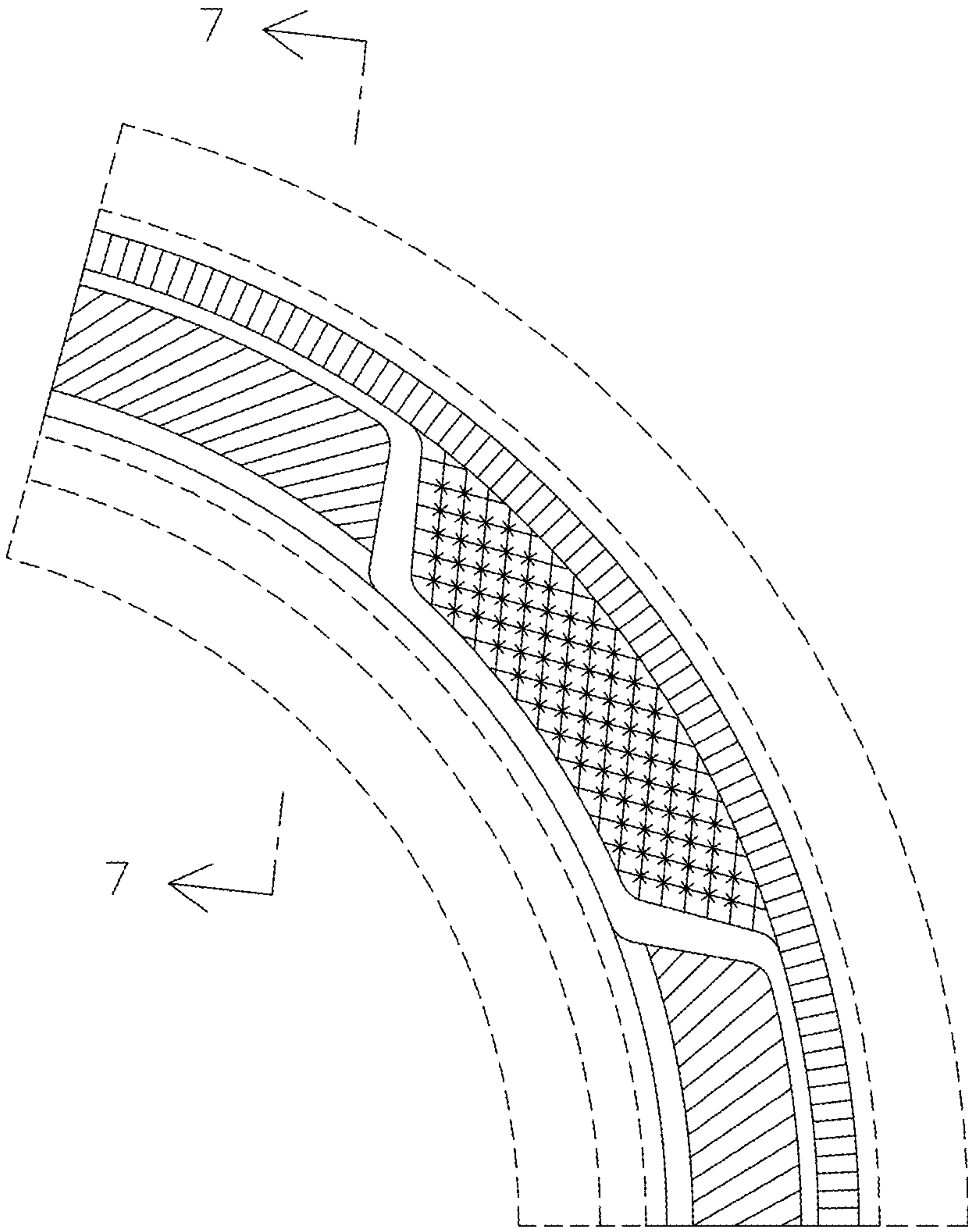

FIG. 6

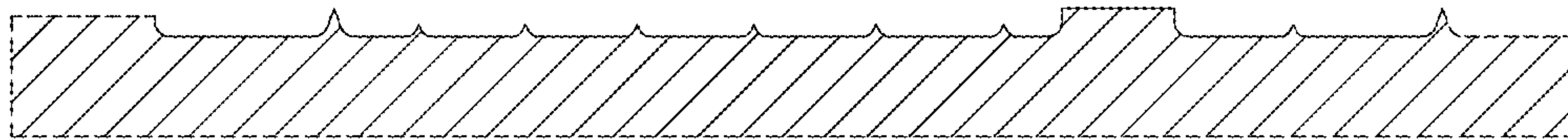

FIG. 7

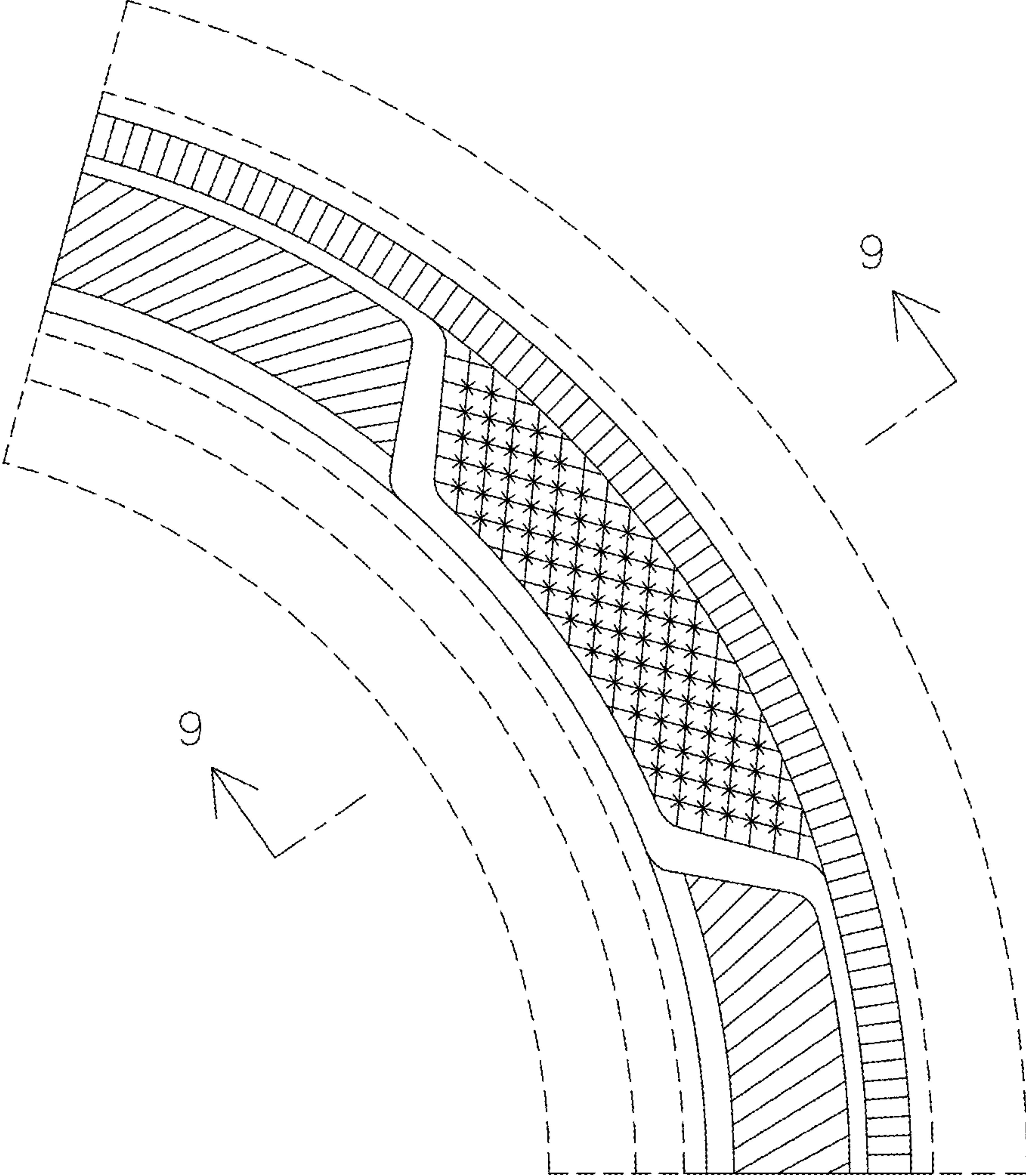

FIG. 8

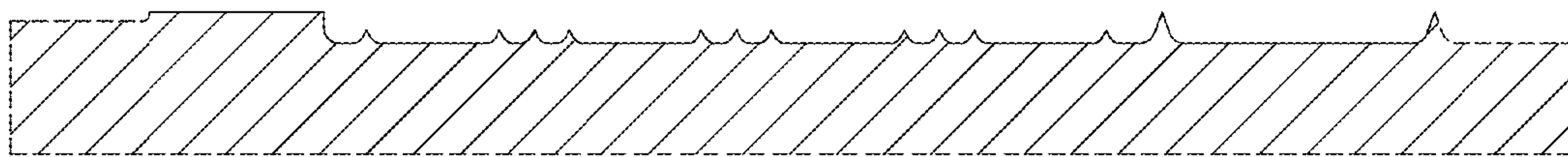

FIG. 9