



US00D776969S

(12) **United States Design Patent**
Ishii et al.

(10) **Patent No.:** **US D776,969 S**

(45) **Date of Patent:** **** Jan. 24, 2017**

(54) **VEHICLE SEAT**

FOREIGN PATENT DOCUMENTS

(71) Applicant: **TACHI-S CO., LTD.**, Tokyo (JP)

JP 1005171 S 3/1998
JP 1497916 S 5/2014

(72) Inventors: **Atsushi Ishii**, Tokyo (JP); **Shinichi Mizuno**, Tokyo (JP)

(Continued)

(73) Assignee: **Tachi-S Co., Ltd.**, Tokyo (JP)

Primary Examiner — Mimosa De

(**) Term: **14 Years**

(74) *Attorney, Agent, or Firm* — Miles & Stockbridge P.C.

(21) Appl. No.: **29/499,498**

(57) **CLAIM**

(22) Filed: **Aug. 15, 2014**

We claim the ornamental design for a vehicle seat, as shown and described.

(30) **Foreign Application Priority Data**

Feb. 27, 2014 (JP) 2014-004103

(51) **LOC (10) Cl.** **06-01**

DESCRIPTION

(52) **U.S. Cl.**

USPC **D6/716.1; D6/356**

(58) **Field of Classification Search**

USPC D6/334-336, 356, 367, 368, 374, 375,
D6/716, 716.1, 716.2, 716.3, 716.4

CPC B60N 2/48; B60N 2/22; B60N 2/449;
B60N 2/4882; A47C 7/022; A47C 7/18

See application file for complete search history.

(56) **References Cited**

U.S. PATENT DOCUMENTS

D371,465 S * 7/1996 Stulik D6/356
D383,320 S * 9/1997 Gilbertson D6/356
D480,570 S * 10/2003 Gryp D6/356
D605,420 S * 12/2009 Krauss D6/356
D626,349 S * 11/2010 Bashir D6/356
D644,047 S * 8/2011 Fujii D6/356
D644,461 S * 9/2011 Fujii D6/716
D644,462 S * 9/2011 Fujii D6/716
D644,463 S * 9/2011 Fujii D6/356
D644,464 S * 9/2011 Fujii D6/356
D644,465 S * 9/2011 Fujii D6/716
D665,181 S * 8/2012 Crepeau D6/356

(Continued)

FIG. 1 is a front, top and right side perspective view of a vehicle seat showing our new design;
FIG. 2 is a front elevational view thereof;
FIG. 3 is a rear elevational view thereof;
FIG. 4 is a right side elevational view thereof;
FIG. 5 is a left side elevational view thereof;
FIG. 6 is a top plan view thereof;
FIG. 7 is a bottom plan view thereof;
FIG. 8 is an enlarged cross sectional view taken along line 8-8 in FIG. 4 thereof;
FIG. 9 is a cross-sectional view taken along line 9-9 in FIG. 5 thereof; and,
FIG. 10 is an enlarged cross sectional view taken along line 10-10 in FIG. 9.

The dashed-dot-dashed lines represent the boundary lines of the claimed design.

The heavier weight dashed broken lines shown on the seat in FIGS. 1, 2, 4, 5, and 8 are understood to represent stitching.

The broken lines shown in the drawings represent portions of the vehicle seat that form no part of the claimed design.

1 Claim, 9 Drawing Sheets

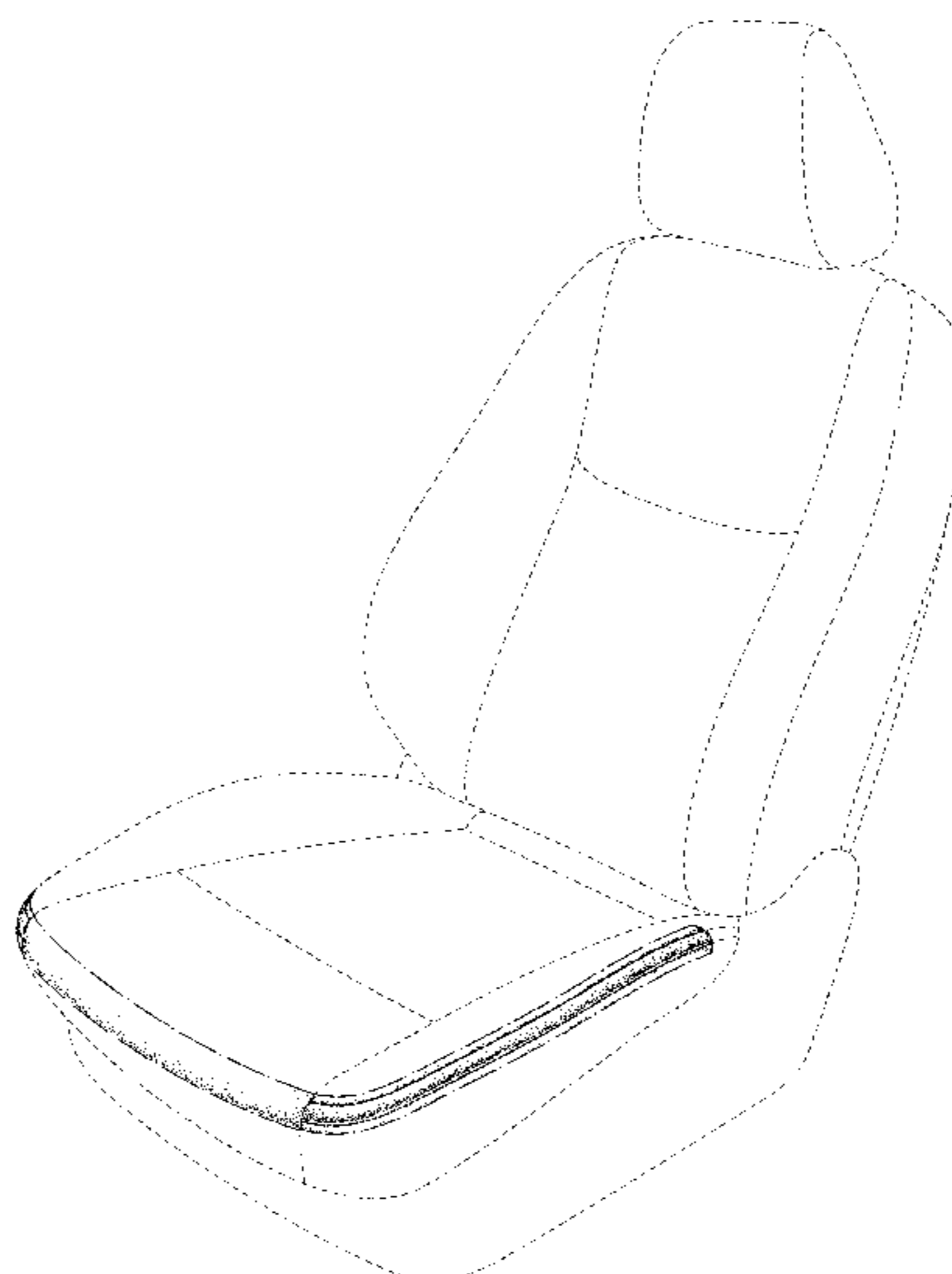

(56)

References Cited

U.S. PATENT DOCUMENTS

D682,571 S *	5/2013	Ali	D6/356
D684,386 S *	6/2013	Ashley	D6/356
D684,387 S *	6/2013	Ashley	D6/356
D684,391 S *	6/2013	Ashley	D6/356
D723,820 S *	3/2015	Ashley	D6/356
D724,332 S *	3/2015	Ashley	D6/356
D724,333 S *	3/2015	Ashley	D6/356
D724,334 S *	3/2015	Ashley	D6/356
D737,586 S *	9/2015	Taguchi	D6/356

FOREIGN PATENT DOCUMENTS

JP	1497917 S	5/2014
JP	1502246 S	7/2014

* cited by examiner

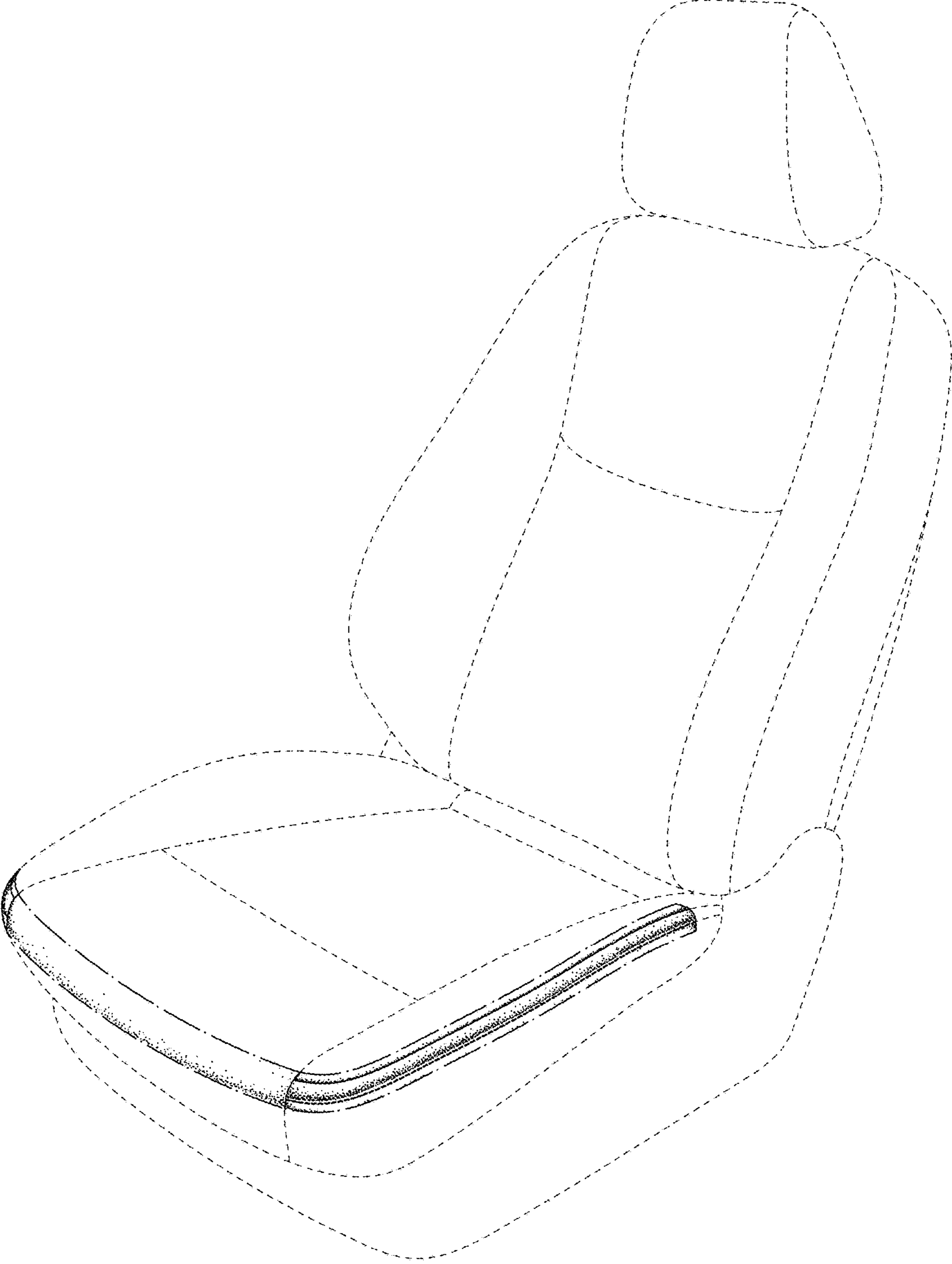

Fig. 1

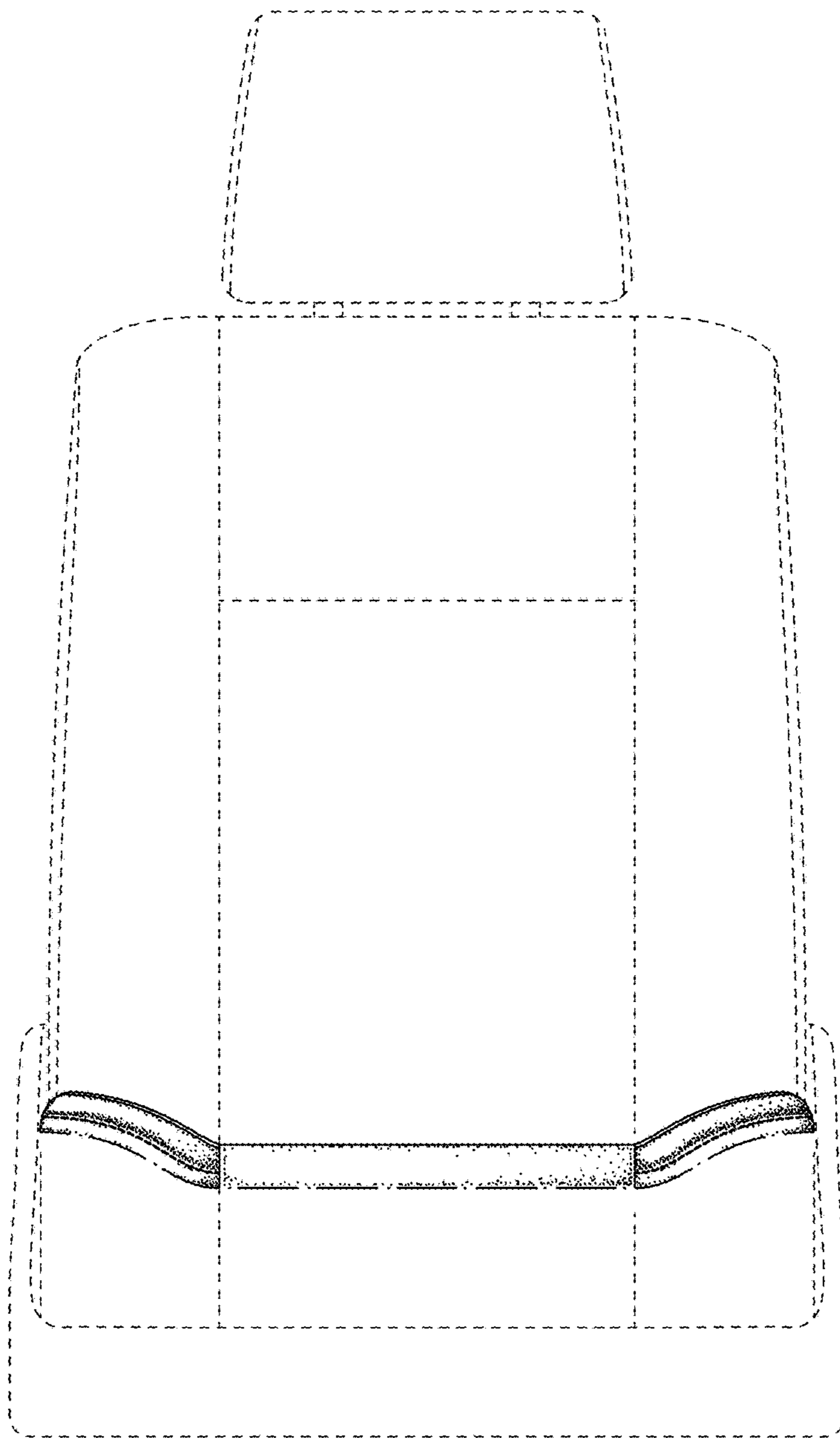

Fig. 2

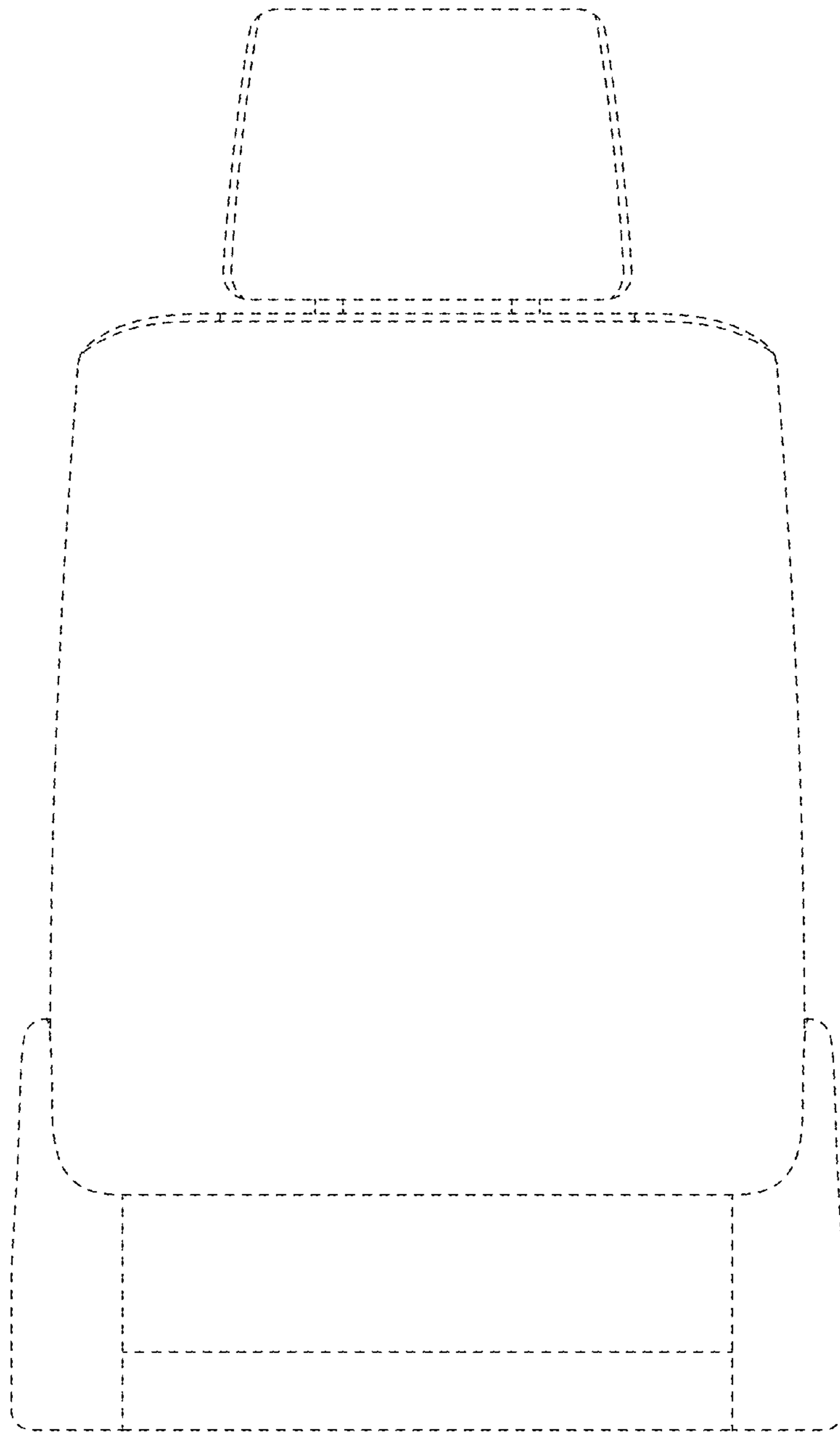

Fig. 3

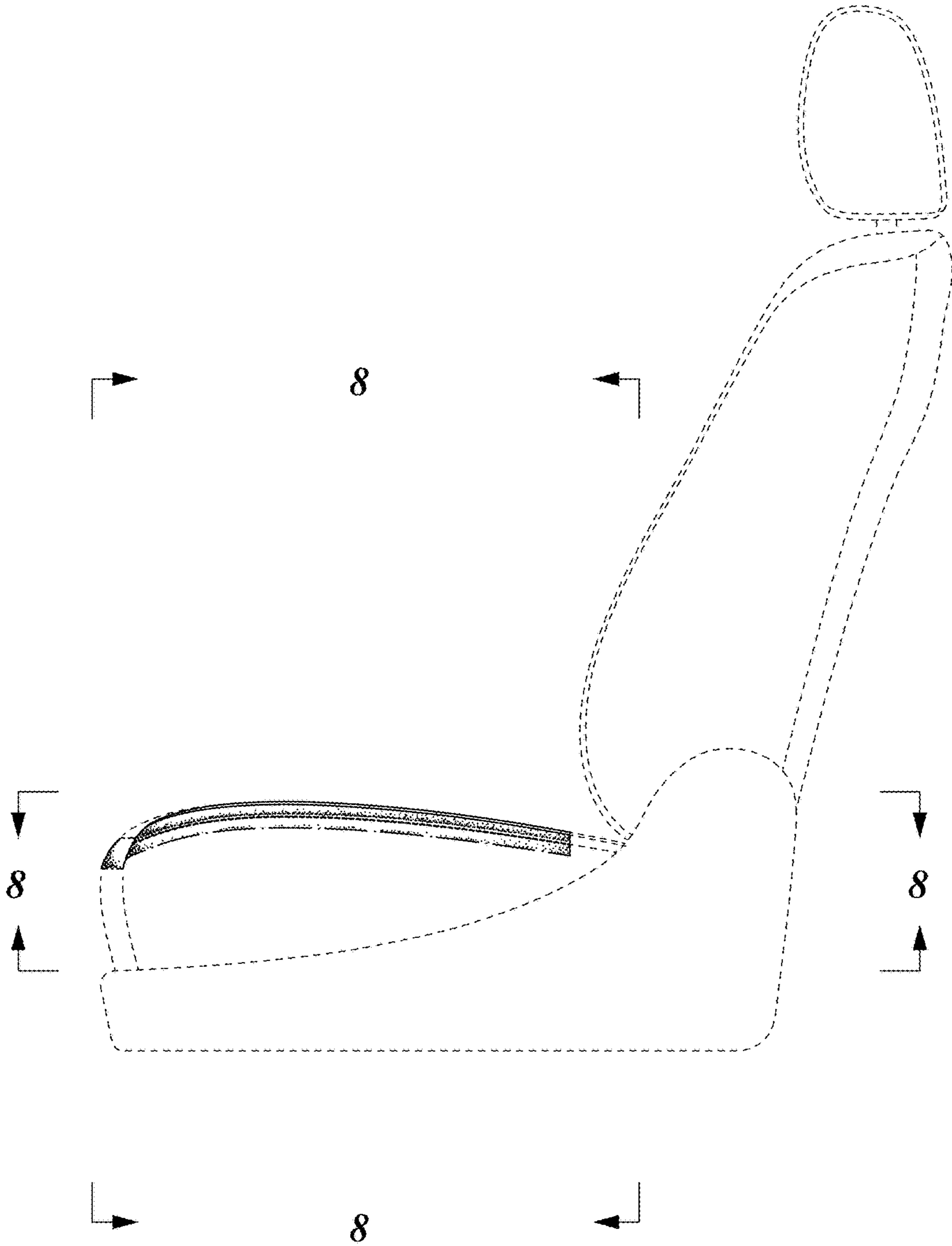

Fig. 4

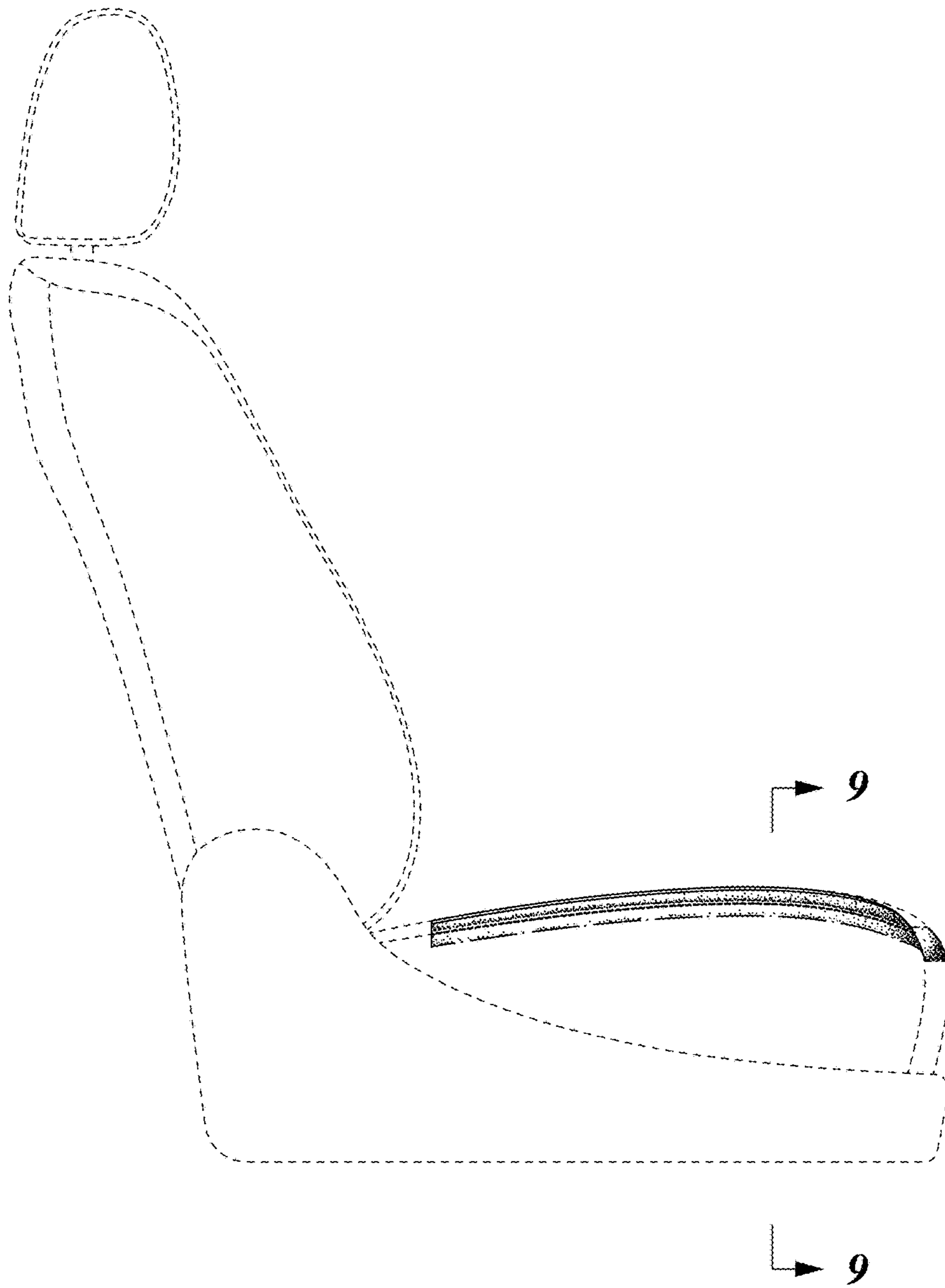

Fig. 5

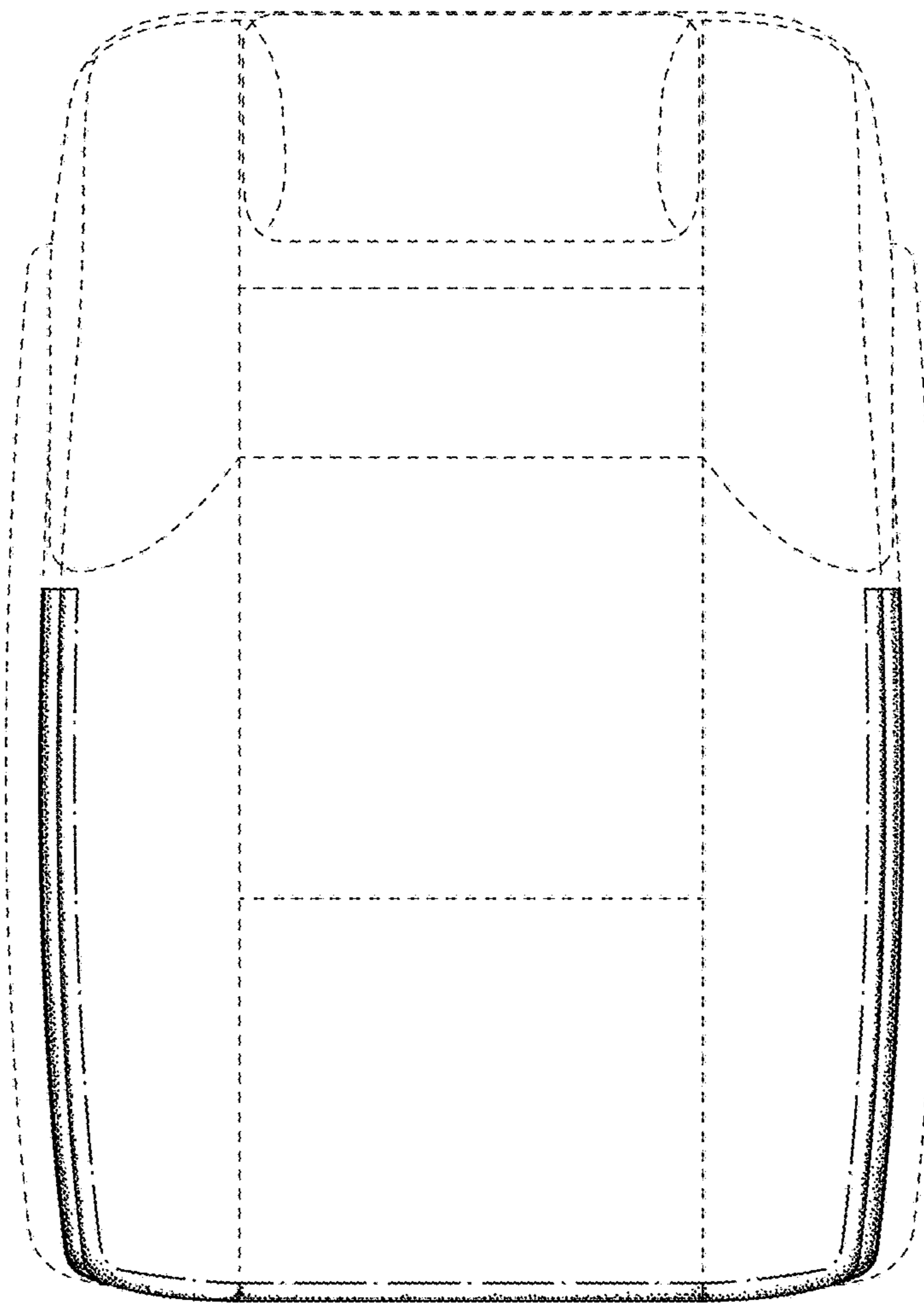

Fig. 6

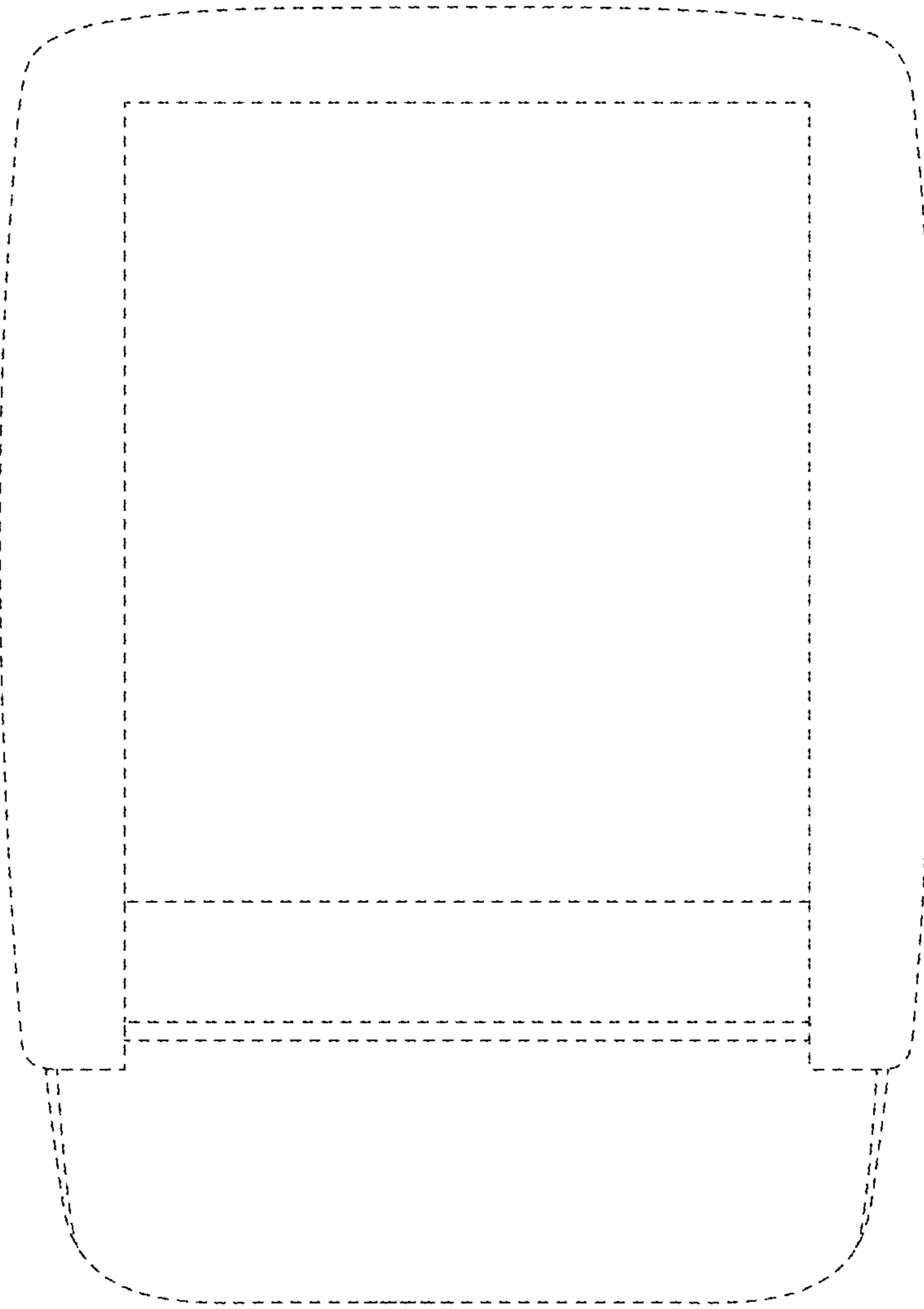

Fig. 7

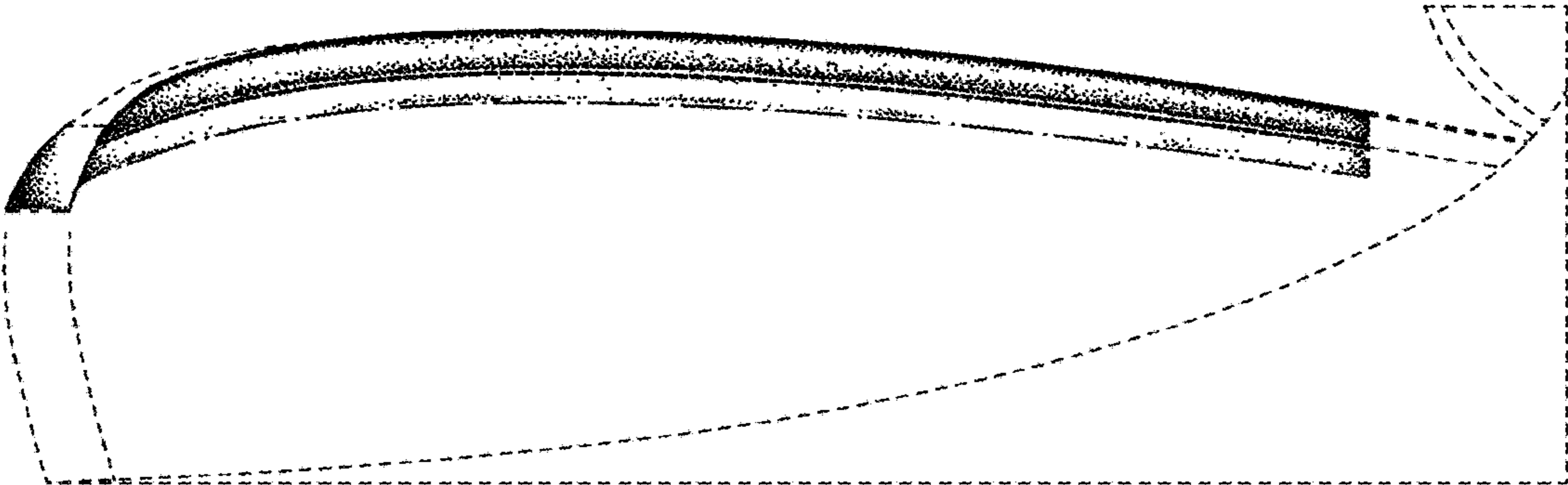

Fig. 8

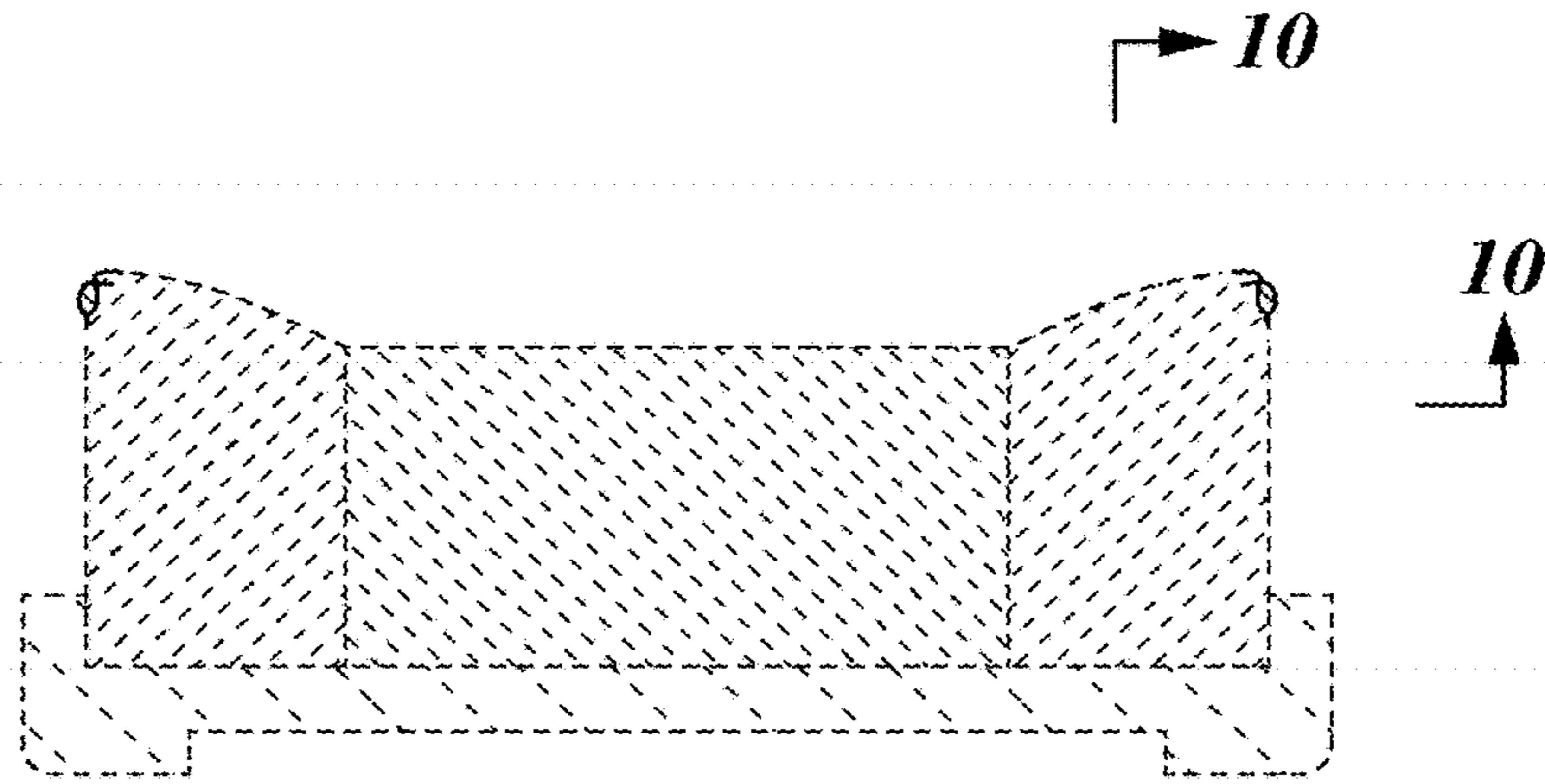

Fig. 9

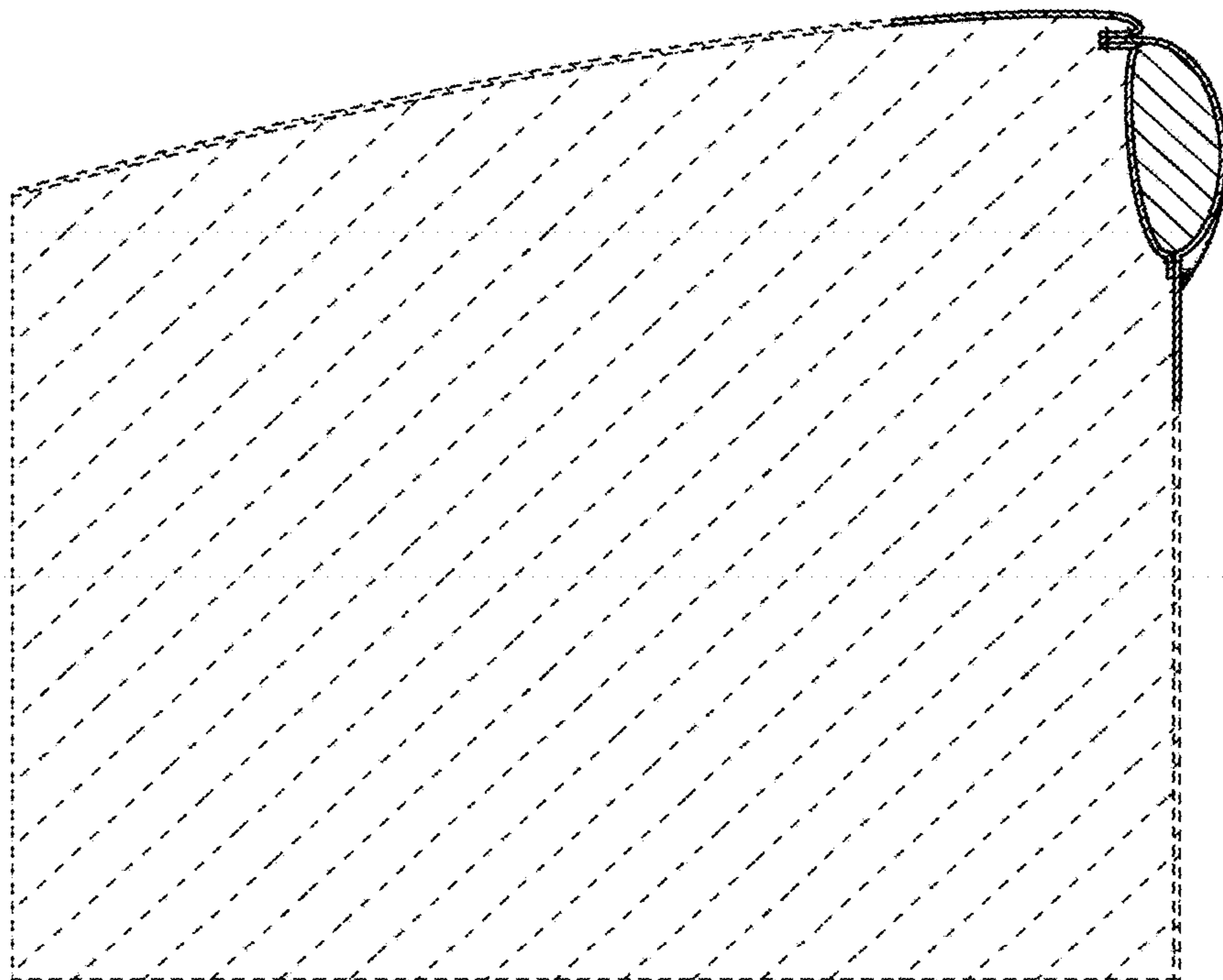

Fig. 10