



US00D776888S

(12) **United States Design Patent**  
**Gu et al.**

(10) **Patent No.:** **US D776,888 S**  
(45) **Date of Patent:** **\*\* Jan. 17, 2017**

(54) **PORTION OF A VACUUM CLEANER**

(71) Applicant: **BISSELL Homecare, Inc.**, Grand Rapids, MI (US)

(72) Inventors: **Yilin Gu**, Shanghai (CN); **Martin Rauch**, Shanghai (CN); **Christopher John Reinke**, Saint Joseph, MI (US)

(73) Assignee: **BISSELL Homecare, Inc.**, Grand Rapids, MI (US)

(\*\*) Term: **14 Years**

(21) Appl. No.: **29/490,968**

(22) Filed: **May 15, 2014**

(51) **LOC (10) Cl.** ..... **15-05**

(52) **U.S. Cl.**  
USPC ..... **D32/22**

(58) **Field of Classification Search**  
USPC ..... D32/17-18, 21-24, 31, 34  
CPC ..... A47L 5/28; A47L 5/32; A47L 5/362;  
A47L 5/365; A47L 5/24; A47L  
5/34; A47L 7/0038; A47L 9/26; A47L  
9/2857; A47L 9/20; A47L 9/02; A47L  
9/322; A47L 9/325; A47L 11/34  
See application file for complete search history.

(56) **References Cited**

**U.S. PATENT DOCUMENTS**

D307,656 S *	5/1990	Yuen	.....	D32/22
D307,657 S *	5/1990	Li	.....	15/329
D418,266 S *	12/1999	Medema	.....	D32/22
D437,666 S *	2/2001	Park	.....	D32/22
D483,160 S *	12/2003	Houghton	.....	D32/18
D510,162 S *	9/2005	Ma	.....	D32/18

D545,011 S *	6/2007	Ågren	.....	D32/22
D564,156 S *	3/2008	Ågren	.....	D32/31
D565,814 S *	4/2008	Ågren	.....	D32/22
D565,816 S *	4/2008	Ågren	.....	D32/22
D574,563 S *	8/2008	Fjellman	.....	D32/22
D582,111 S *	12/2008	Ågren	.....	D32/22
D613,469 S *	4/2010	Ågren	.....	D32/22
D636,954 S *	4/2011	Liu	.....	D32/22
D643,980 S *	8/2011	Kim	.....	D32/22
D680,286 S *	4/2013	Gray	.....	D32/22
D728,176 S *	4/2015	Yu	.....	D32/22
D743,124 S *	11/2015	Gray	.....	D32/22
2007/0136984 A1 *	6/2007	Hsu	.....	A47L 5/225 15/339
2007/0271724 A1 *	11/2007	Hakan	.....	A47L 5/225 15/329
2015/0067981 A1 *	3/2015	Faremo	.....	A47L 5/28 15/354

\* cited by examiner

*Primary Examiner* — Ruth McInroy

(74) *Attorney, Agent, or Firm* — McGarry Bair PC

(57) **CLAIM**

The ornamental design for a portion of a vacuum cleaner, as shown and described.

**DESCRIPTION**

FIG. 1 is a front and right-side perspective view of a portion of a vacuum cleaner showing our new design;  
FIG. 2 is a front view thereof;  
FIG. 3 is a rear view thereof;  
FIG. 4 is a left side view thereof;  
FIG. 5 is a right side view thereof; and,  
FIG. 6 is an enlarged top view thereof.  
The broken lines in the figures illustrate the boundaries of the claim, and form no part of the claimed design.

**1 Claim, 4 Drawing Sheets**

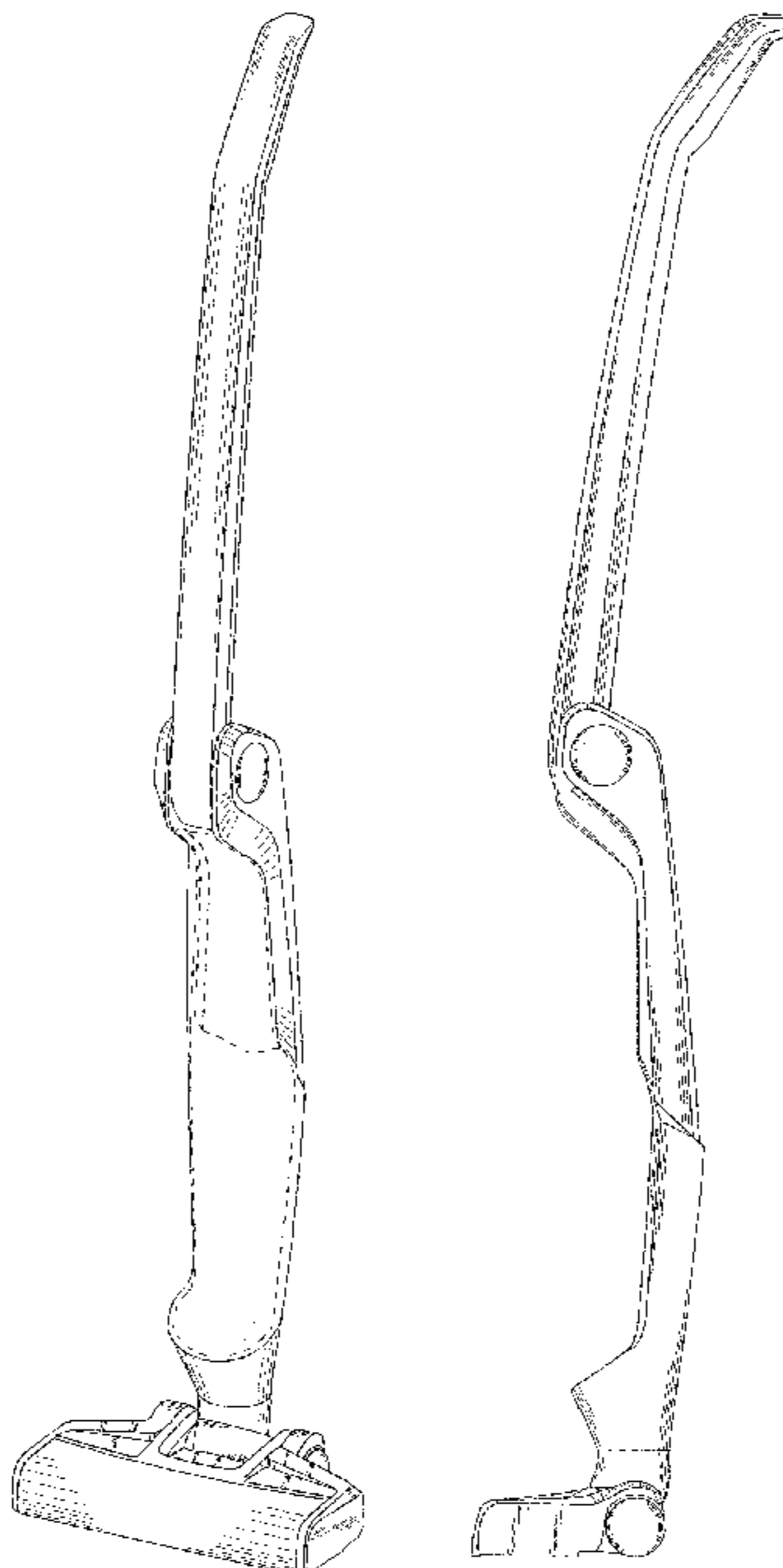

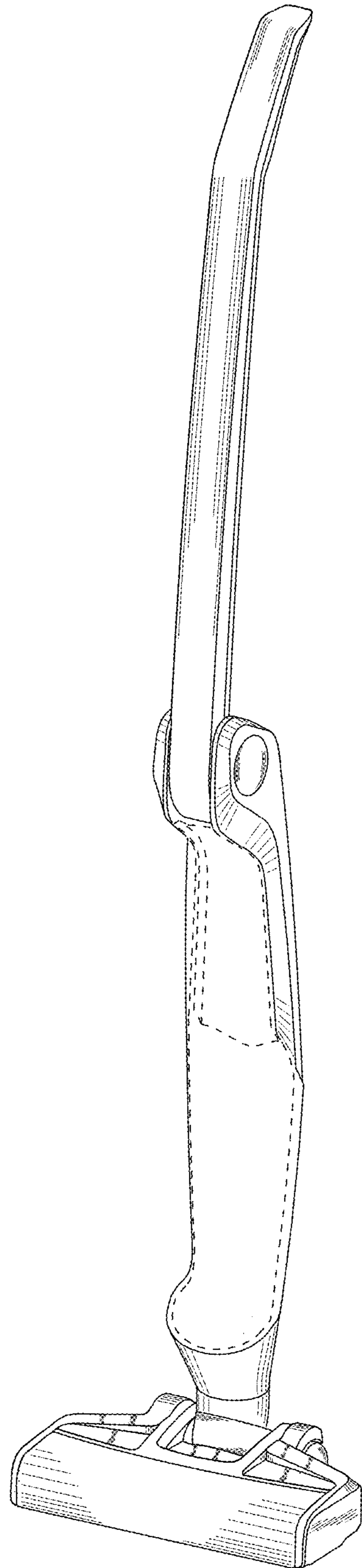

**FIG. 1**

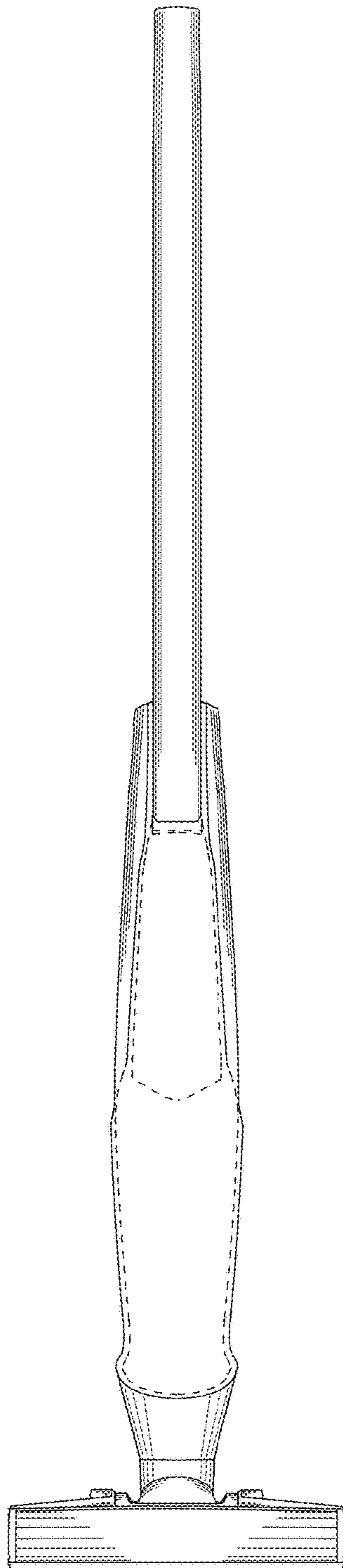
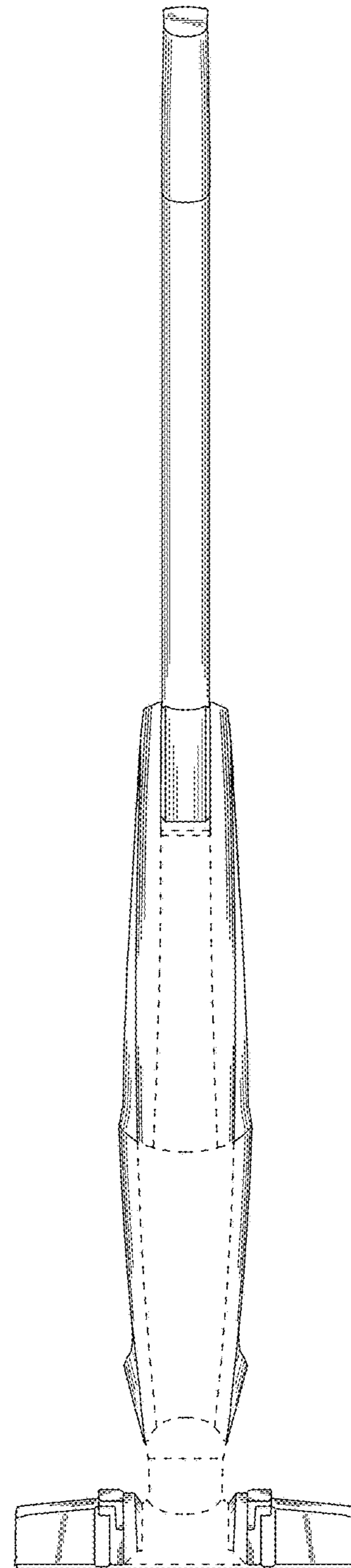

FIG. 3



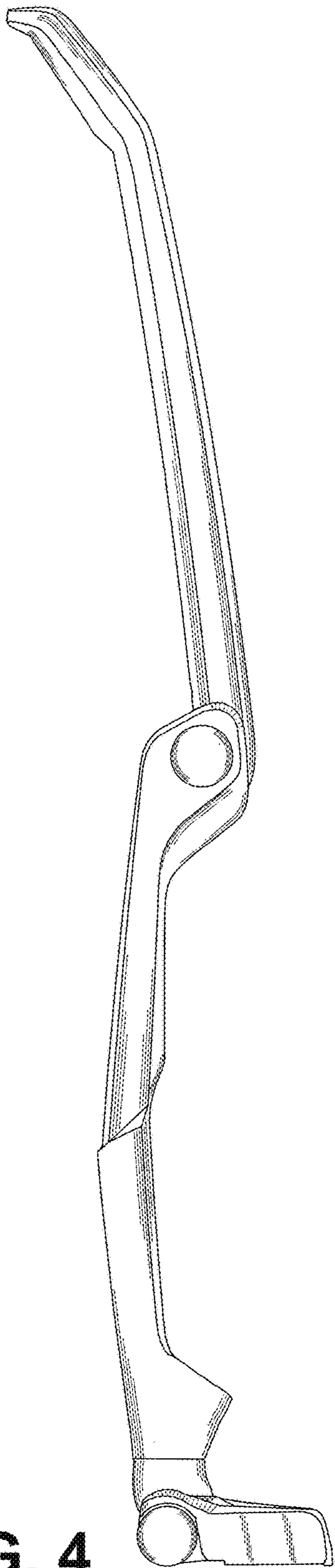
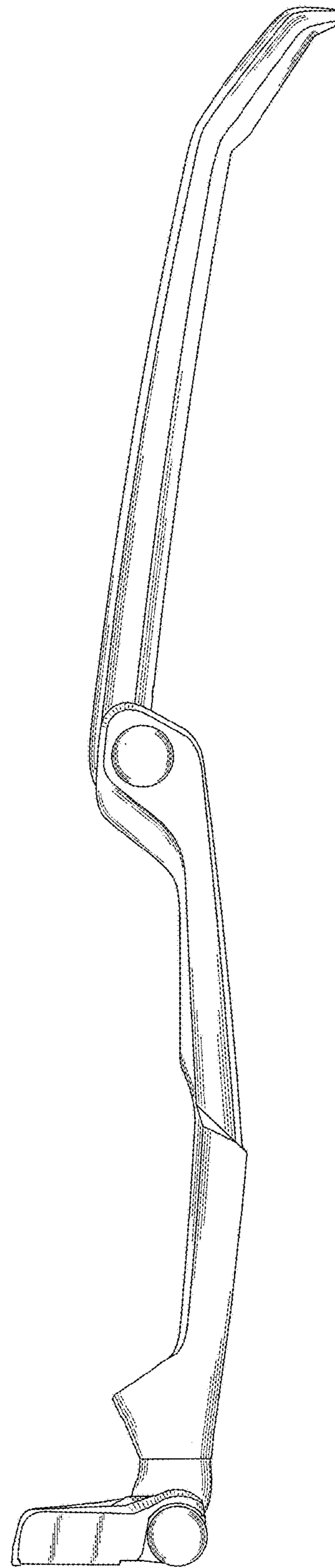
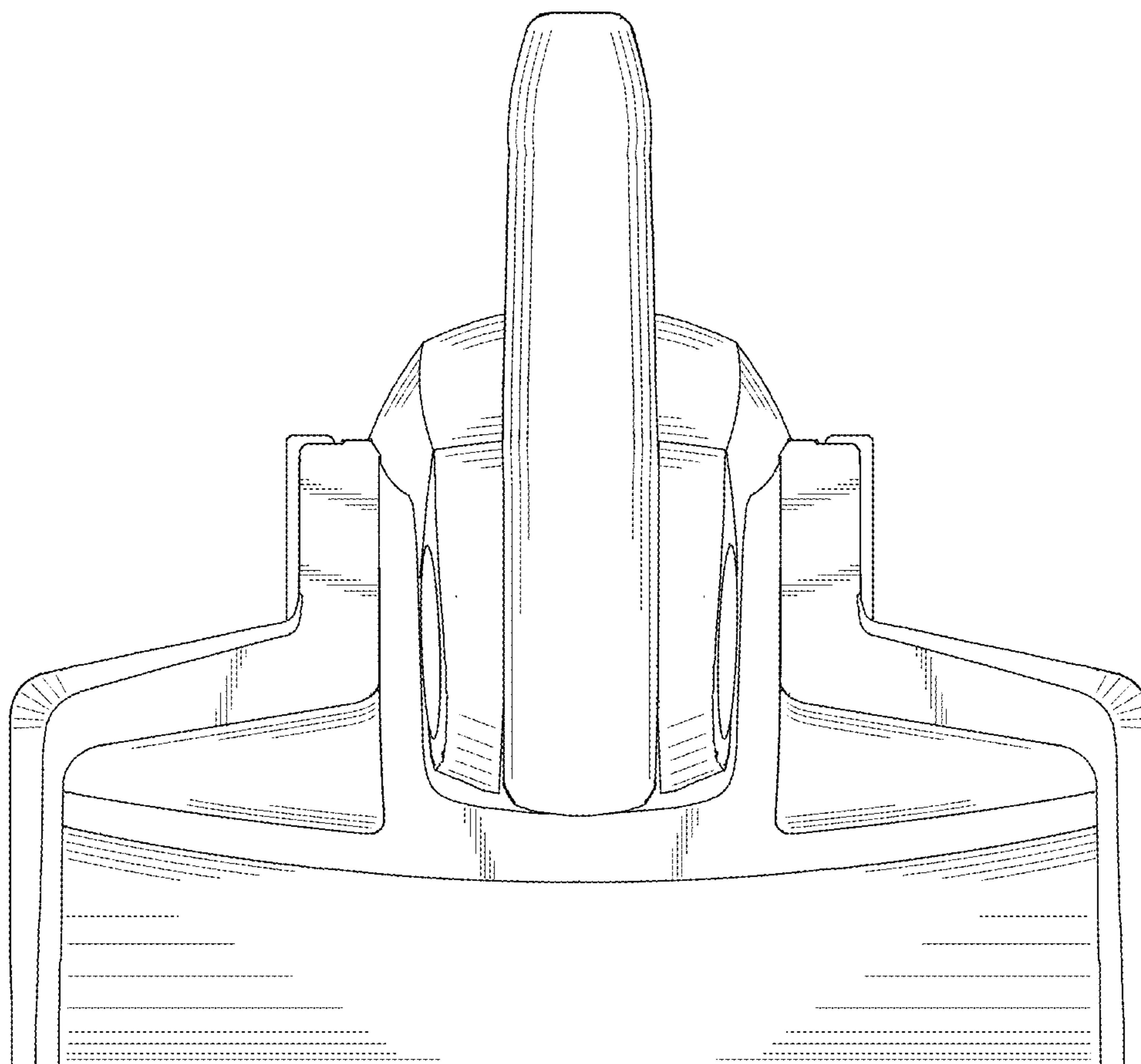

FIG. 5





**FIG. 6**