



US00D776618S

(12) **United States Design Patent** (10) **Patent No.:** **US D776,618 S**  
**Wieser et al.** (45) **Date of Patent:** **\*\* Jan. 17, 2017**

(54) **VEHICLE INTERFACE CONNECTOR DEVICE**

*Primary Examiner* — Daniel Bui  
(74) *Attorney, Agent, or Firm* — Maginot, Moore & Beck LLP

(71) Applicant: **Robert Bosch GmbH**, Stuttgart (DE)

(57) **CLAIM**

(72) Inventors: **Matthias Wieser**, Stuttgart (DE);  
**Thomas Frank**, Berlin (DE); **Bankoley Florian**, Berlin (DE)

The ornamental design for a vehicle interface connector device, as shown and described.

(73) Assignee: **Robert Bosch GmbH**, Stuttgart (DE)

**DESCRIPTION**

(\*\*) Term: **14 Years**

Cross reference is made to copending U.S. design patent application Ser. No. 29/523,544 entitled “Vehicle Interface Connector Device” by Wieser et al., which was filed on Apr. 10, 2015; U.S. design patent application Ser. No. 29/523,546 entitled “Vehicle Interface Connector Device” by Wieser et al., which was filed on Apr. 10, 2015; U.S. design patent application Ser. No. 29/523,548 entitled “Vehicle Interface Connector Device” by Wieser et al., which was filed on Apr. 10, 2015; U.S. design patent application Ser. No. 29/523,550 entitled “Vehicle Interface Connector Device” by Wieser et al., which was filed on Apr. 10, 2015; U.S. design patent application Ser. No. 29/523,553 entitled “Vehicle Interface Connector Device” by Wieser et al., which was filed on Apr. 10, 2015; and U.S. design patent application Ser. No. 29/523,556 entitled “Vehicle Interface Connector Device” by Wieser et al., which was filed on Apr. 10, 2015.

(21) Appl. No.: **29/523,559**

(22) Filed: **Apr. 10, 2015**

(30) **Foreign Application Priority Data**

Oct. 10, 2014 (EM) ..... 002555235

(51) **LOC (10) Cl.** ..... **13-03**

(52) **U.S. Cl.**  
USPC ..... **D13/147**

(58) **Field of Classification Search**  
USPC ..... D13/133, 134, 146, 147, 148, 153, 154,  
D13/184, 199  
See application file for complete search history.

FIG. 1 is a perspective view of a vehicle interface connector device showing our new design;  
FIG. 2 is a left side elevational view thereof;  
FIG. 3 is a right side elevational view thereof;  
FIG. 4 is a top plan view thereof;  
FIG. 5 is a bottom plan view thereof;  
FIG. 6 is a front elevational view thereof; and,  
FIG. 7 is a rear elevational view thereof.

(56) **References Cited**

**U.S. PATENT DOCUMENTS**

D204,136 S *	3/1966	Schaeffer	.....	D13/133
D233,438 S *	10/1974	Bruner	.....	D13/148
D361,745 S *	8/1995	Geroux	.....	D13/120
D411,983 S *	7/1999	Awbrey	.....	D13/148
8,872,402 B2 *	10/2014	Tanaka	.....	H02K 11/0068 310/43

The broken lines shown in the drawings illustrate portions of the vehicle interface connector device that form no part of the claimed design.

\* cited by examiner

**1 Claim, 7 Drawing Sheets**

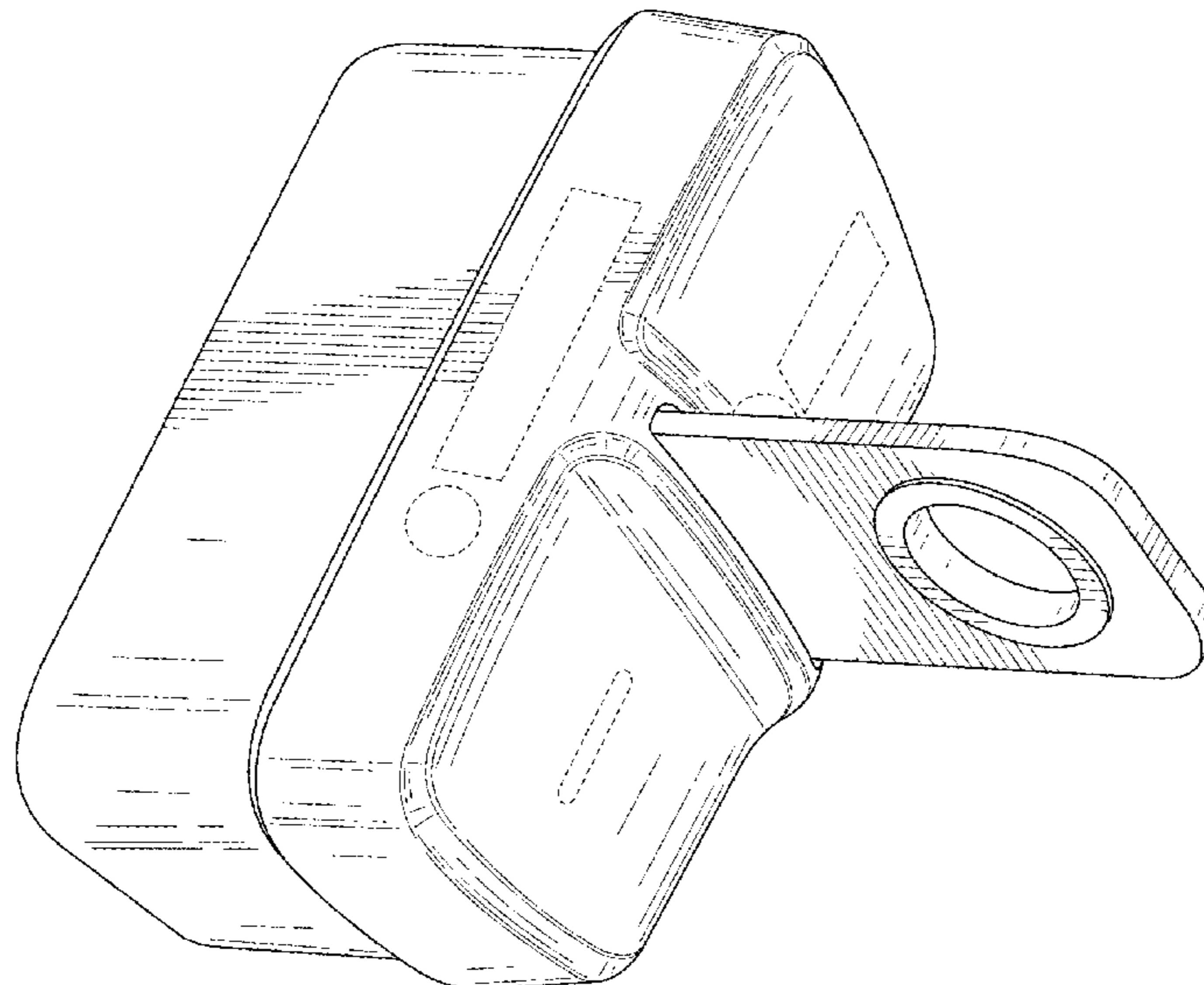

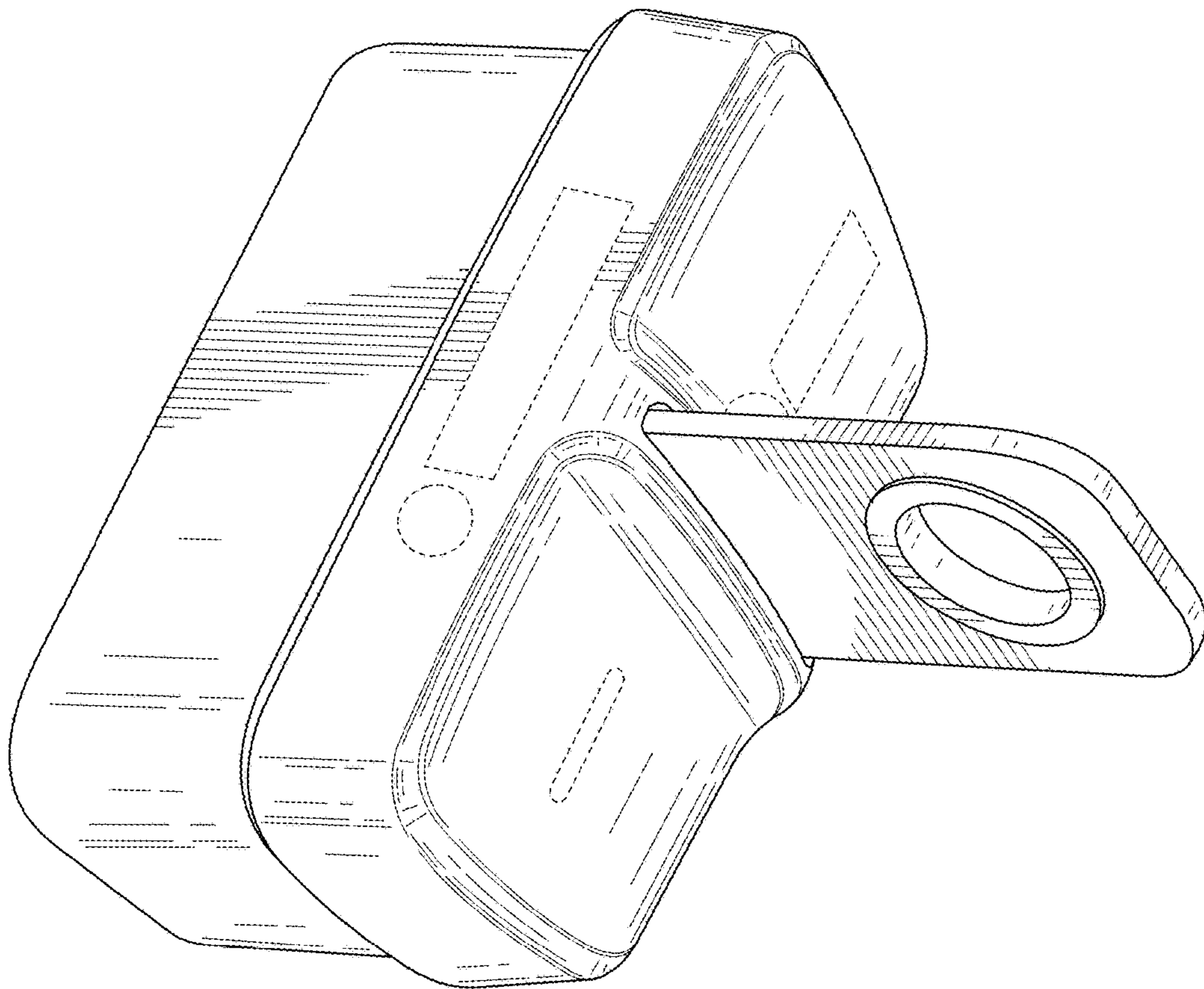

FIG. 1

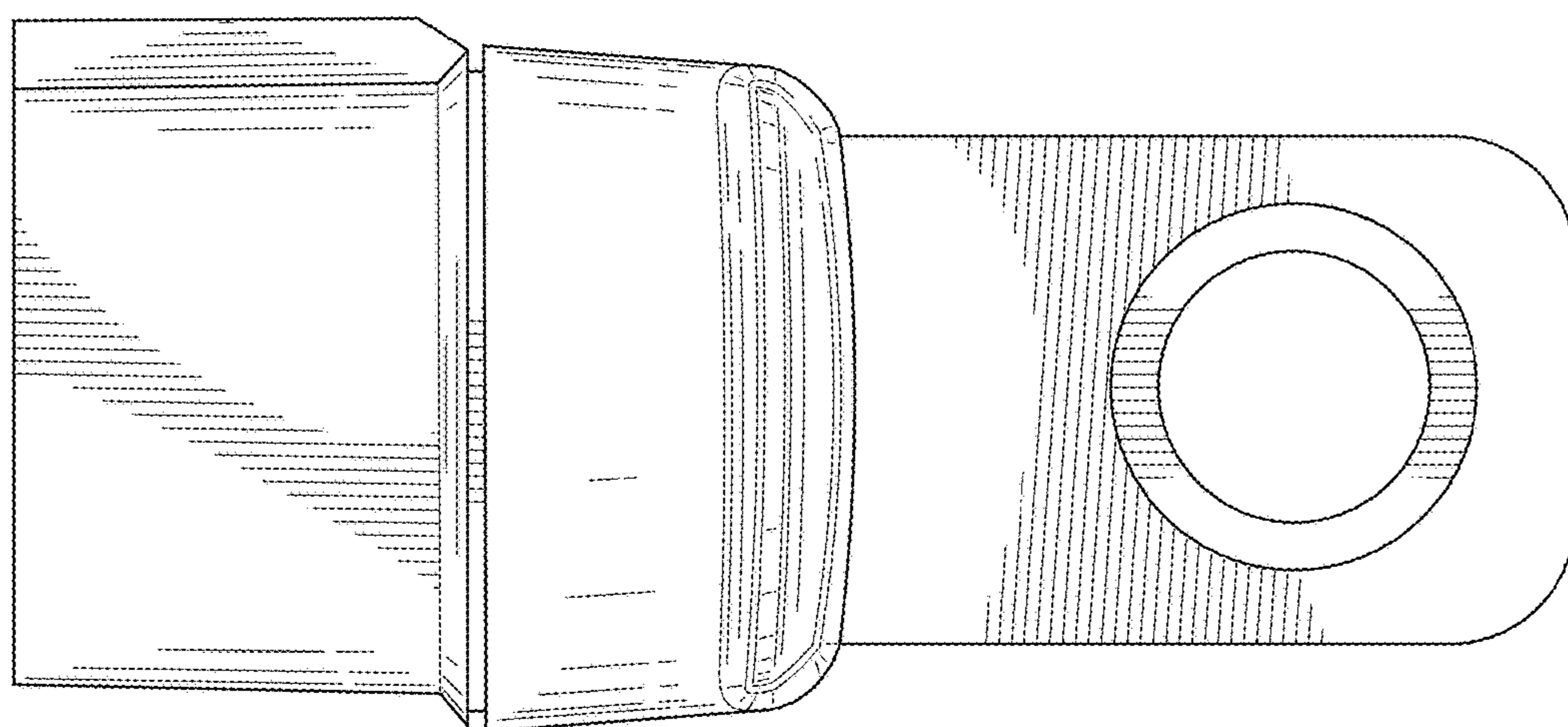

FIG. 2

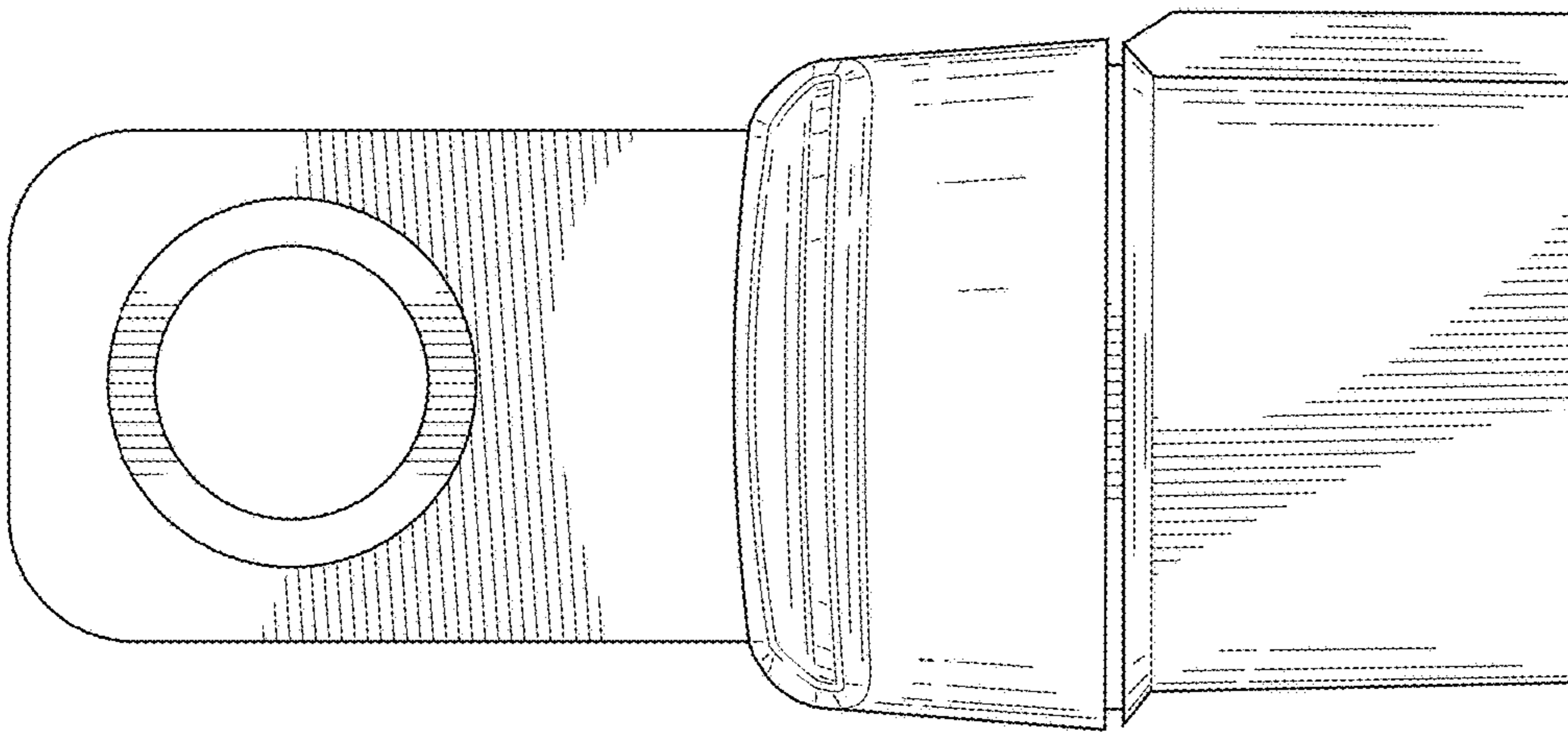

FIG. 3

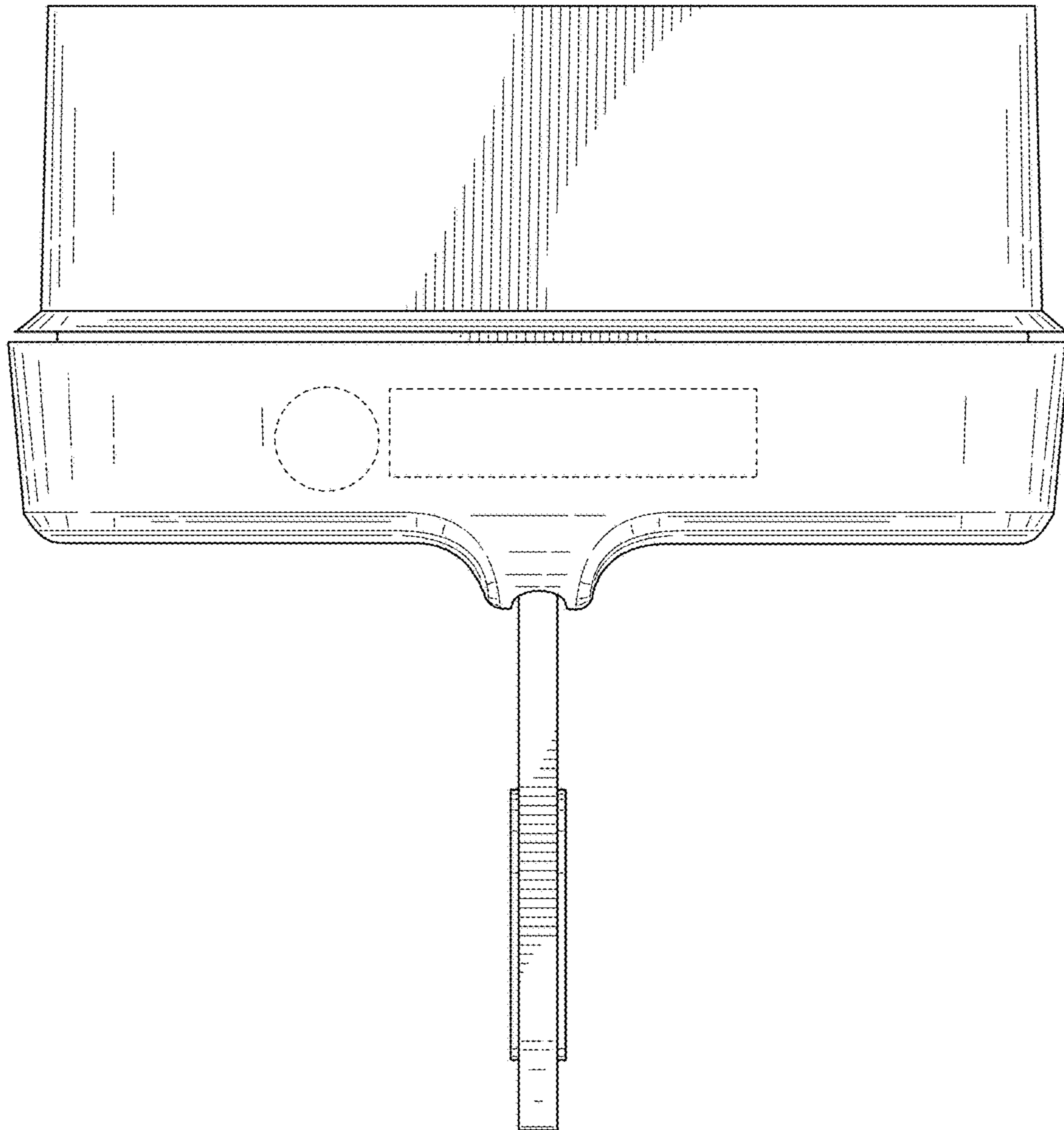

FIG. 4

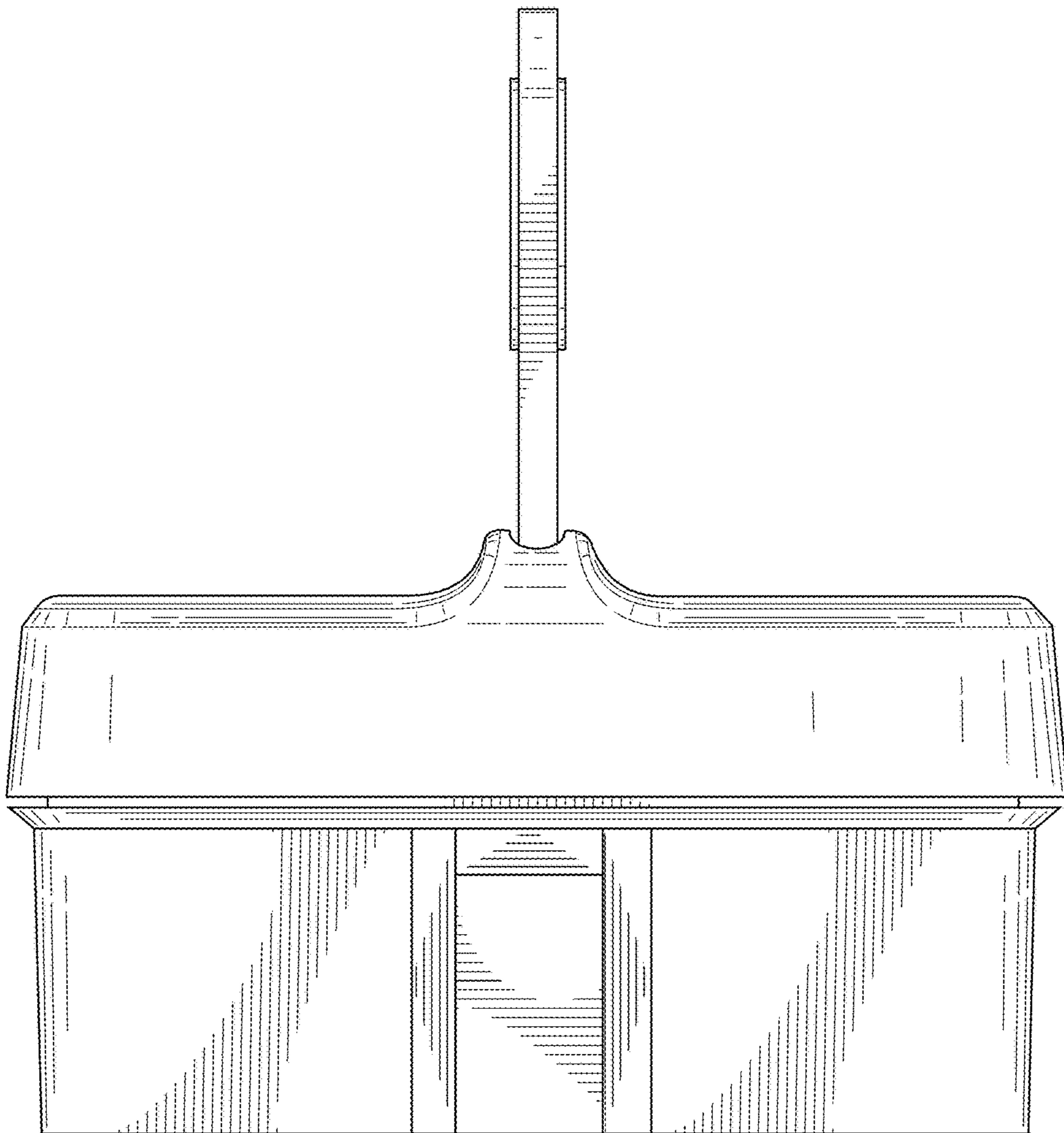
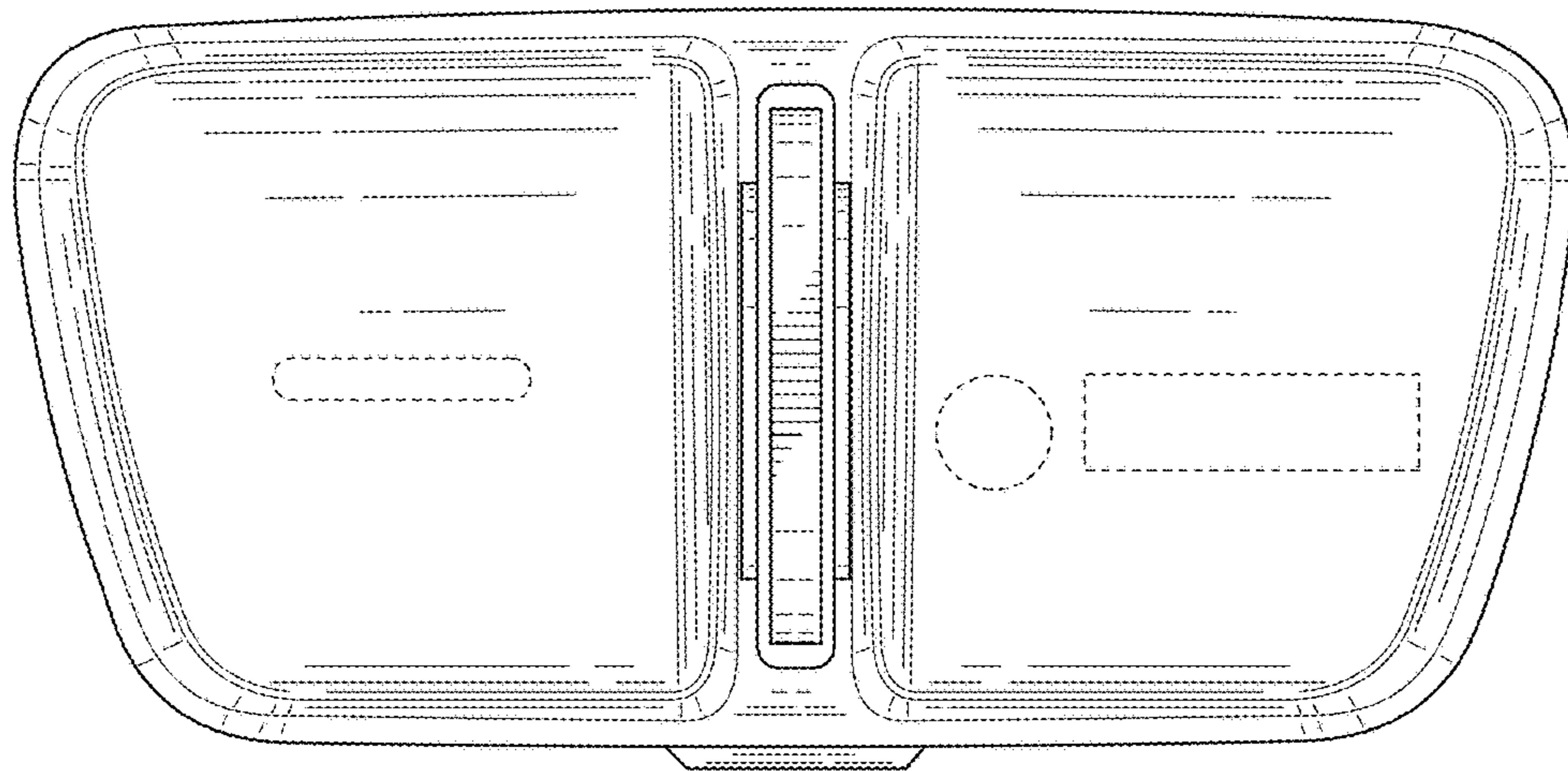

FIG. 5



**FIG. 6**

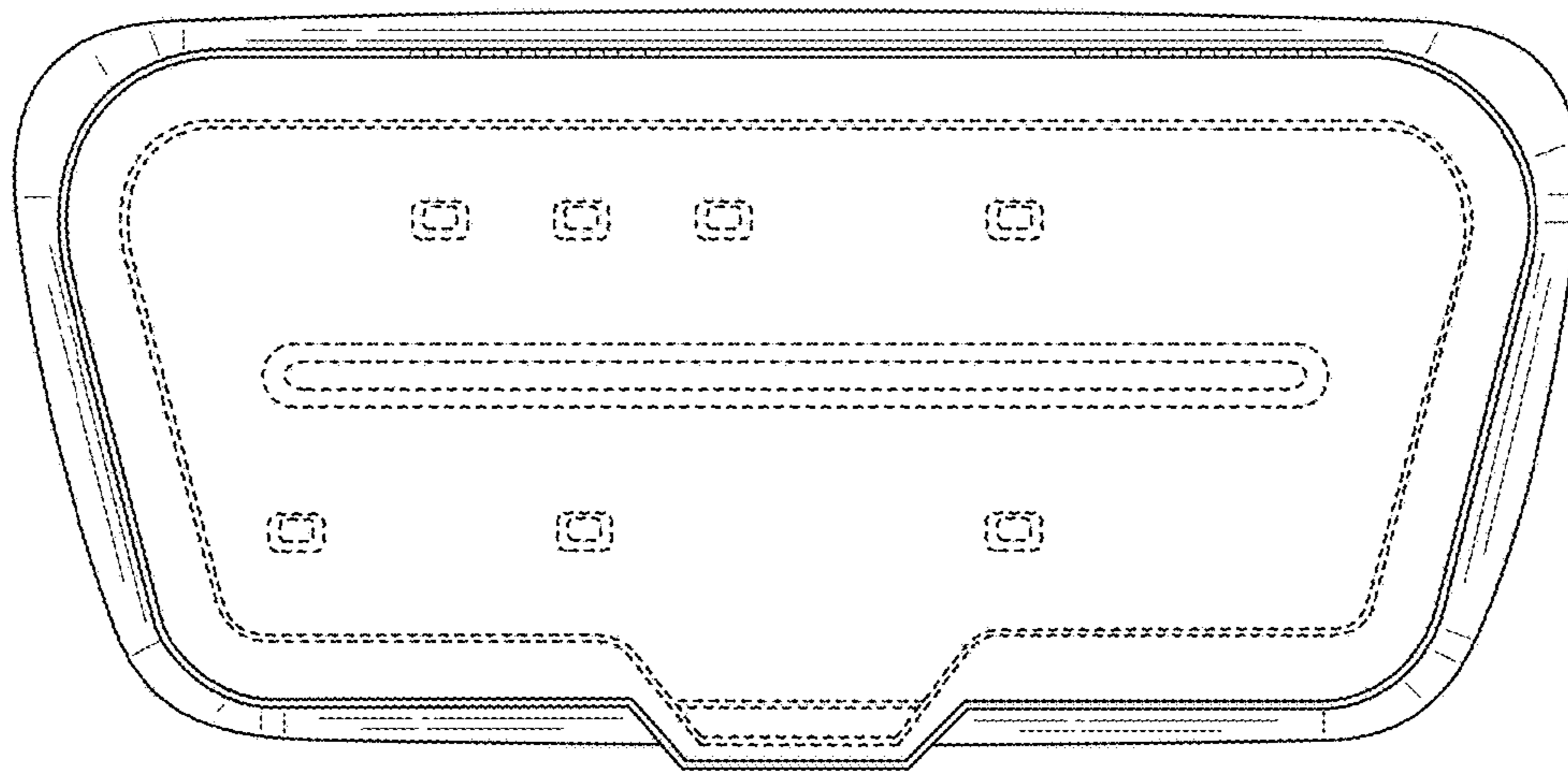

FIG. 7