



US00D776106S

(12) **United States Design Patent** (10) **Patent No.:** **US D776,106 S**
Gessford et al. (45) **Date of Patent:** **** Jan. 10, 2017**

- (54) **STACKING SYSTEM FOR ELECTRONIC EQUIPMENT**
- (71) Applicant: **TEKTRONIX, INC.**, Beaverton, OR (US)
- (72) Inventors: **Marc A. Gessford**, North Plains, OR (US); **Samuel A. Cassel**, Portland, OR (US); **Lawrence M. Le Mon**, Beaverton, OR (US); **Neil Clayton**, Hillsboro, OR (US); **Stanley G. Miller**, Beaverton, OR (US); **Jessica Anna Dunn**, Beaverton, OR (US); **Karl A. Rinder**, Beaverton, OR (US); **Michael J. Wadzita**, Vancouver, WA (US); **Thuy T. Nguyen**, Beaverton, OR (US); **Michael C. Moore**, Beaverton, OR (US)
- (73) Assignee: **TEKTRONIX, INC.**, Beaverton, OR (US)

(**) Term: **15 Years**

(21) Appl. No.: **29/539,197**

(22) Filed: **Sep. 11, 2015**

(51) **LOC (10) Cl.** **14-02**

(52) **U.S. Cl.**
USPC **D14/313**

(58) **Field of Classification Search**
USPC D14/240, 300, 301, 308, 310, 313, 314, D14/348-356, 364-368, 188; D13/123, D13/158, 162, 184, 199; 312/223.1-223.3, 351.11; 360/99.01-99.12; 369/34.01-36.01; 361/679.31-679.33, 679.37, 679.39, 361/679.46, 679.53, 679.4, 679.41, 727
(Continued)

(56) **References Cited**

U.S. PATENT DOCUMENTS

- D310,825 S * 9/1990 Crease D14/355
 - D319,225 S * 8/1991 Kline D14/368
- (Continued)

Primary Examiner — Freda S Nunn
(74) *Attorney, Agent, or Firm* — Michael A. Nelson; Marger Johnson

(57) **CLAIM**

The ornamental design for a stacking system for electronic equipment, as shown and described.

DESCRIPTION

FIG. 1 is a perspective view of a first aspect of the stacking system for electronic equipment, in which both pieces of electronic equipment are right-side up.
 FIG. 2 is a front view of the stacking system for electronic equipment of FIG. 1.
 FIG. 3 is a rear view of the stacking system for electronic equipment of FIG. 1.
 FIG. 4 is a right side view of the stacking system for electronic equipment of FIG. 1.
 FIG. 5 is a left side view of the stacking system for electronic equipment of FIG. 1.
 FIG. 6 is a top view of the stacking system for electronic equipment of FIG. 1.
 FIG. 7 is a bottom view of the stacking system for electronic equipment of FIG. 1.
 FIG. 8 is a perspective view of a second aspect of the stacking system for electronic equipment, in which the lower piece of electronic equipment is upside down.
 FIG. 9 is a front view of the stacking system for electronic equipment of FIG. 8.
 FIG. 10 is a rear view of the stacking system for electronic equipment of FIG. 8.
 FIG. 11 is a right side view of the stacking system for electronic equipment of FIG. 8.
 FIG. 12 is a left side view of the stacking system for electronic equipment of FIG. 8.
 FIG. 13 is a top view of the stacking system for electronic equipment of FIG. 8.
 FIG. 14 is a bottom view of the stacking system for electronic equipment of FIG. 8.
 FIG. 15 is a perspective view of a third aspect of the stacking system for electronic equipment, in which the lower piece of

(Continued)

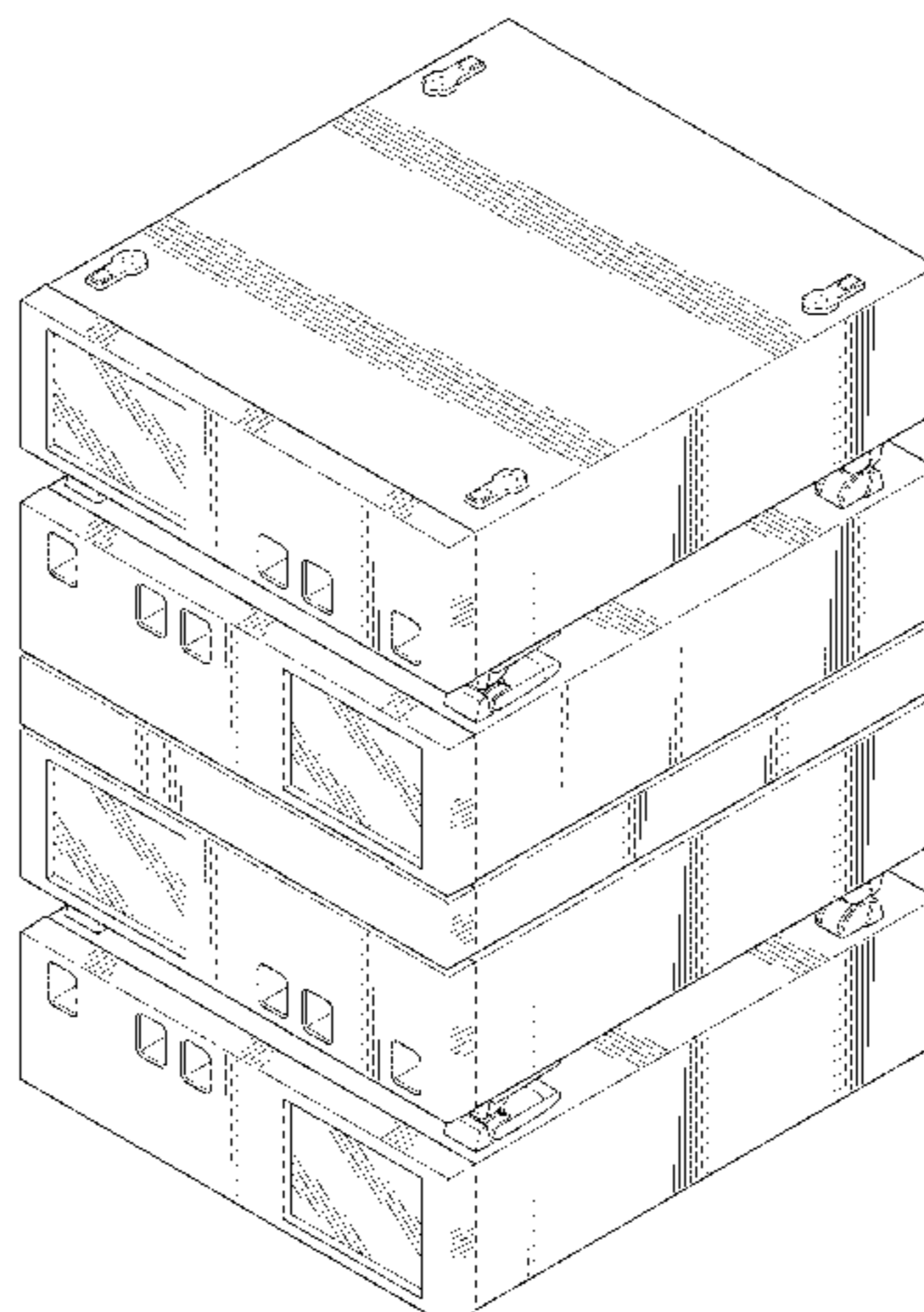

electronic equipment is upside down and both pieces of equipment are secured by a flat, plain, rectangular element. FIG. 16 is a front view of the stacking system for electronic equipment of FIG. 15.

FIG. 17 is a rear view of the stacking system for electronic equipment of FIG. 15.

FIG. 18 is a right side view of the stacking system for electronic equipment of FIG. 15.

FIG. 19 is a left side view of the stacking system for electronic equipment of FIG. 15.

FIG. 20 is a top view of the stacking system for electronic equipment of FIG. 15.

FIG. 21 is a bottom view of the stacking system for electronic equipment of FIG. 15.

FIG. 22 is a perspective view of a fourth aspect of the stacking system for electronic equipment, in which two of the stacking systems for electronic equipment shown in FIG. 15 are separated by an additional piece of electronic equipment.

FIG. 23 is a front view of the stacking system for electronic equipment of FIG. 22.

FIG. 24 is a rear view of the stacking system for electronic equipment of FIG. 22.

FIG. 25 is a right side view of the stacking system for electronic equipment of FIG. 22.

FIG. 26 is a left side view of the stacking system for electronic equipment of FIG. 22.

FIG. 27 is a top view of the stacking system for electronic equipment of FIG. 22; and,

FIG. 28 is a bottom view of the stacking system for electronic equipment of FIG. 22.

The portions of the stacking system for electronic equipment shown in broken lines form no part of the claimed design.

1 Claim, 22 Drawing Sheets

(58) **Field of Classification Search**

CPC G06F 1/20; G06F 1/181; G06F 1/187;
G06F 1/183; G06F 1/184; H05K
7/16; H05K 7/1424; H05K 7/1409; H05K
7/20; H05K 7/20545; H05K
7/20727; H05K 7/1425; H05K 7/1488;
H05K 7/183; H05K 7/14; H05K 5/0021;
H05H 7/20; G11B 33/126; G11B 33/128;
G11B 33/08; G11B 33/02

See application file for complete search history.

(56) **References Cited**

U.S. PATENT DOCUMENTS

D367,852	S *	3/1996	Iino	D14/434
D371,768	S *	7/1996	Kammersgard	D14/313
D380,200	S *	6/1997	Hill	D14/313
D410,231	S *	5/1999	Alo	D14/313
6,085,925	A *	7/2000	Chung	H05K 5/0021 206/511
6,328,612	B1 *	12/2001	Chung	G06F 1/181 361/732
D463,427	S *	9/2002	Sherry	D14/356
D483,756	S *	12/2003	Tanaka	D14/356
6,760,218	B2 *	7/2004	Fan	H05K 5/0021 312/223.2
D505,949	S *	6/2005	Chen	D14/313
D516,550	S *	3/2006	Taniho	D14/314

* cited by examiner

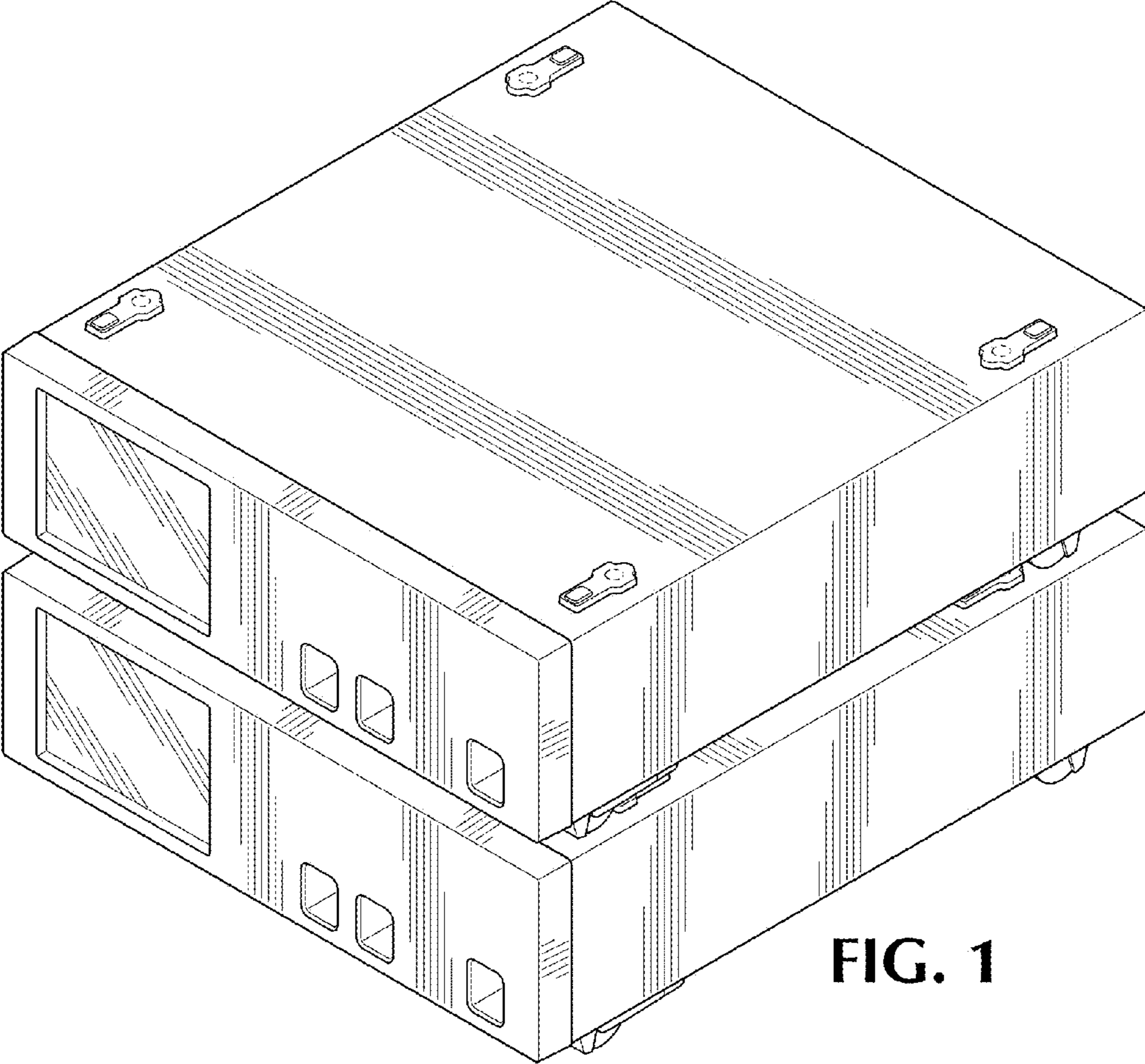

FIG. 1

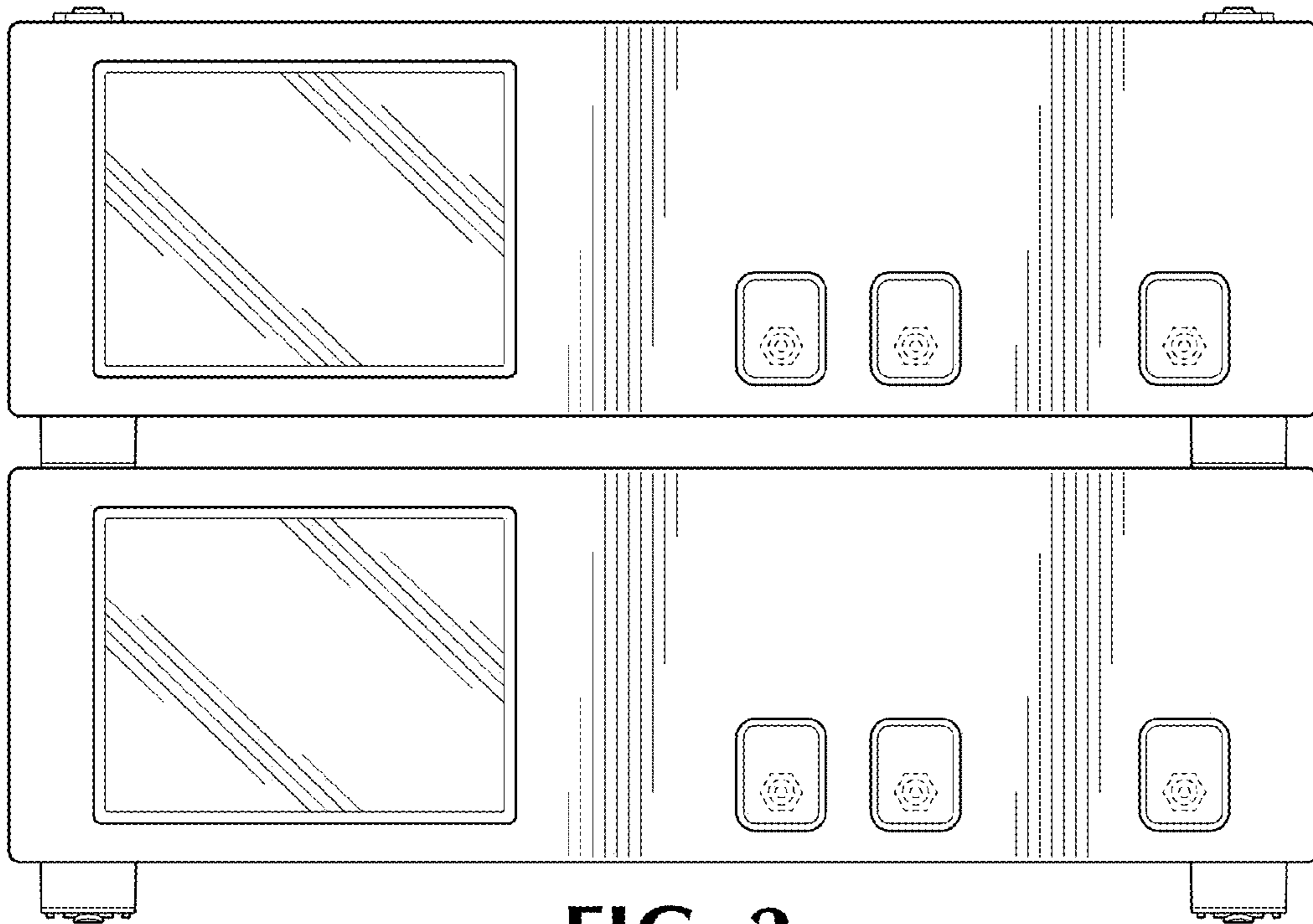

FIG. 2

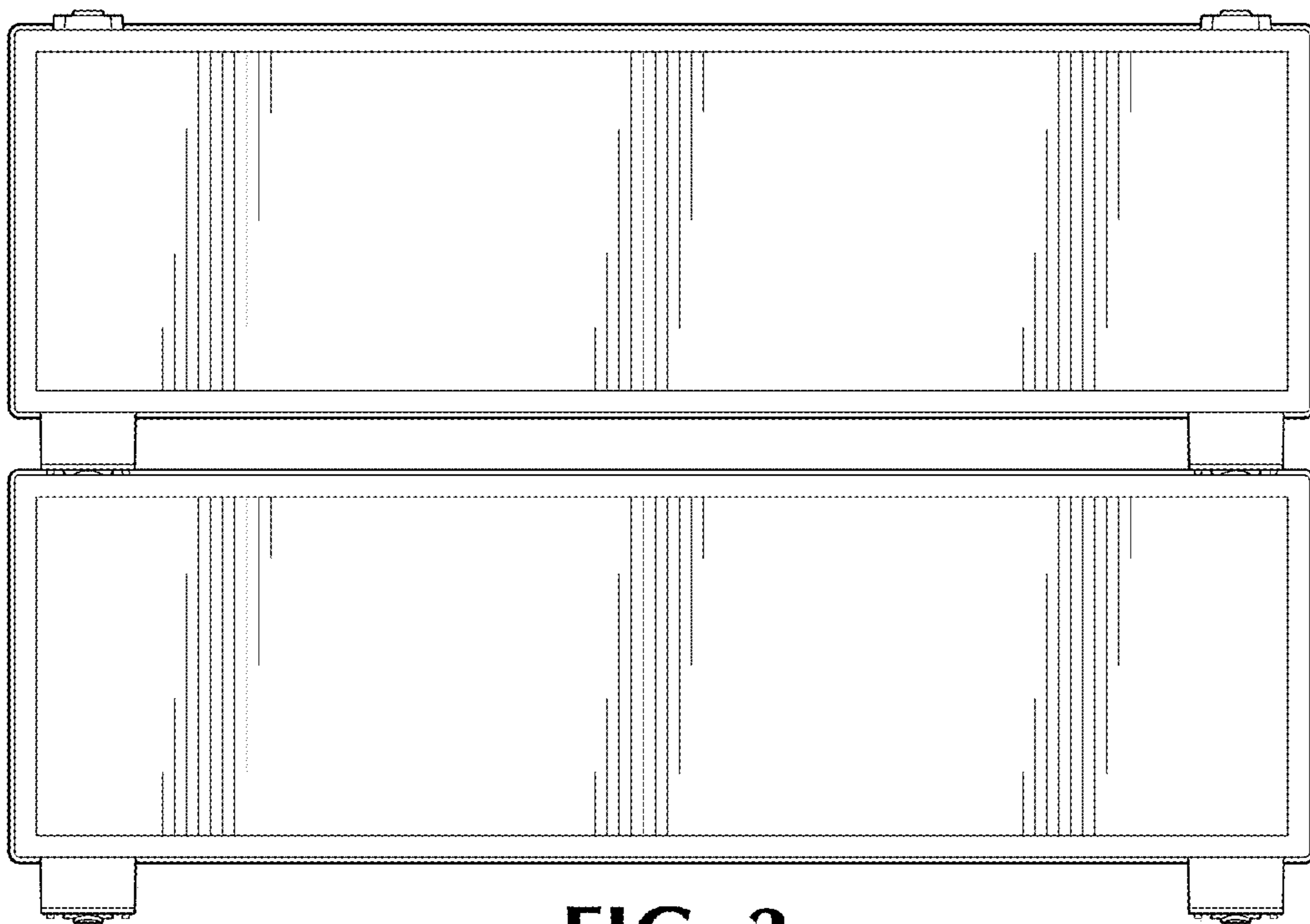

FIG. 3

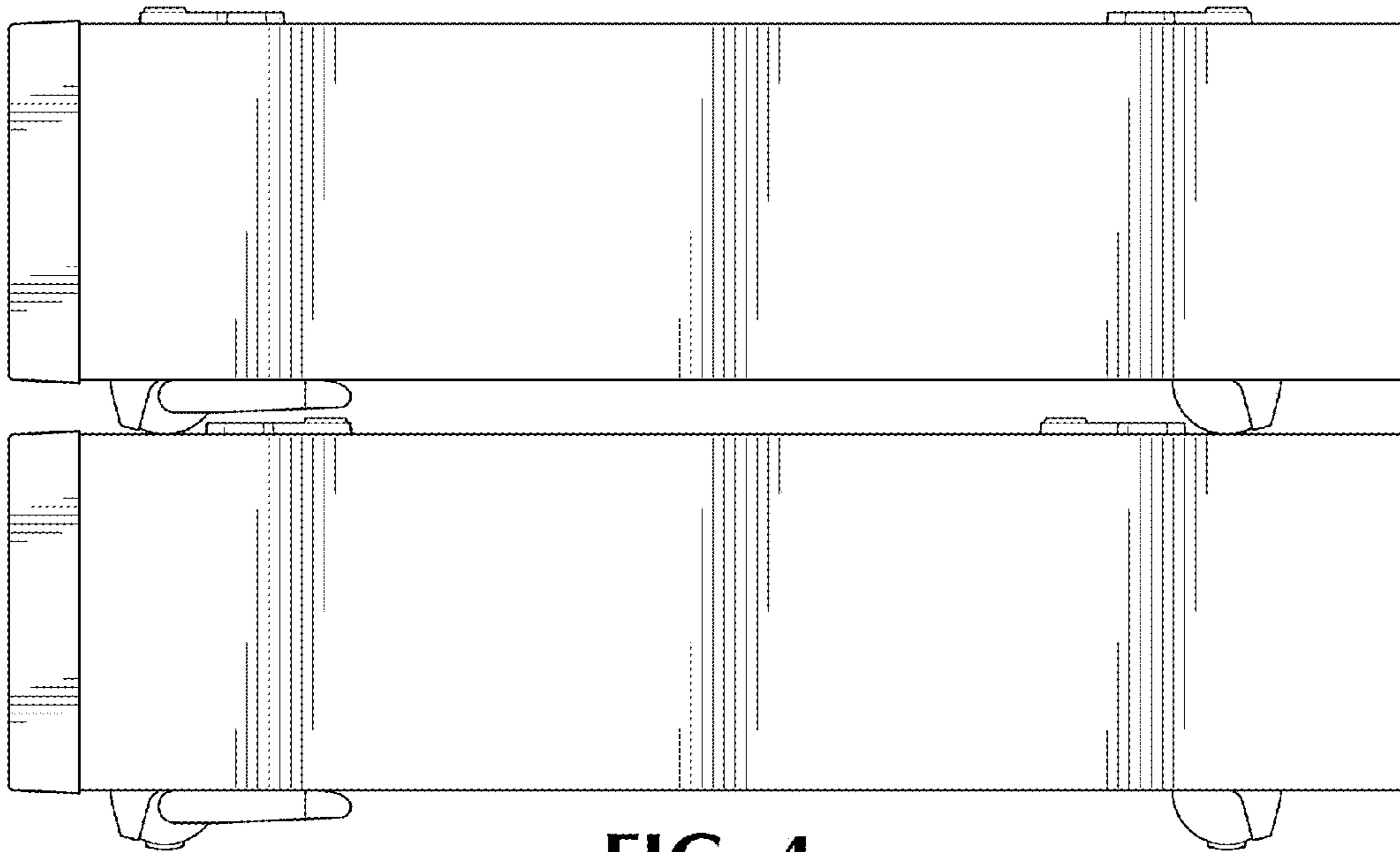

FIG. 4

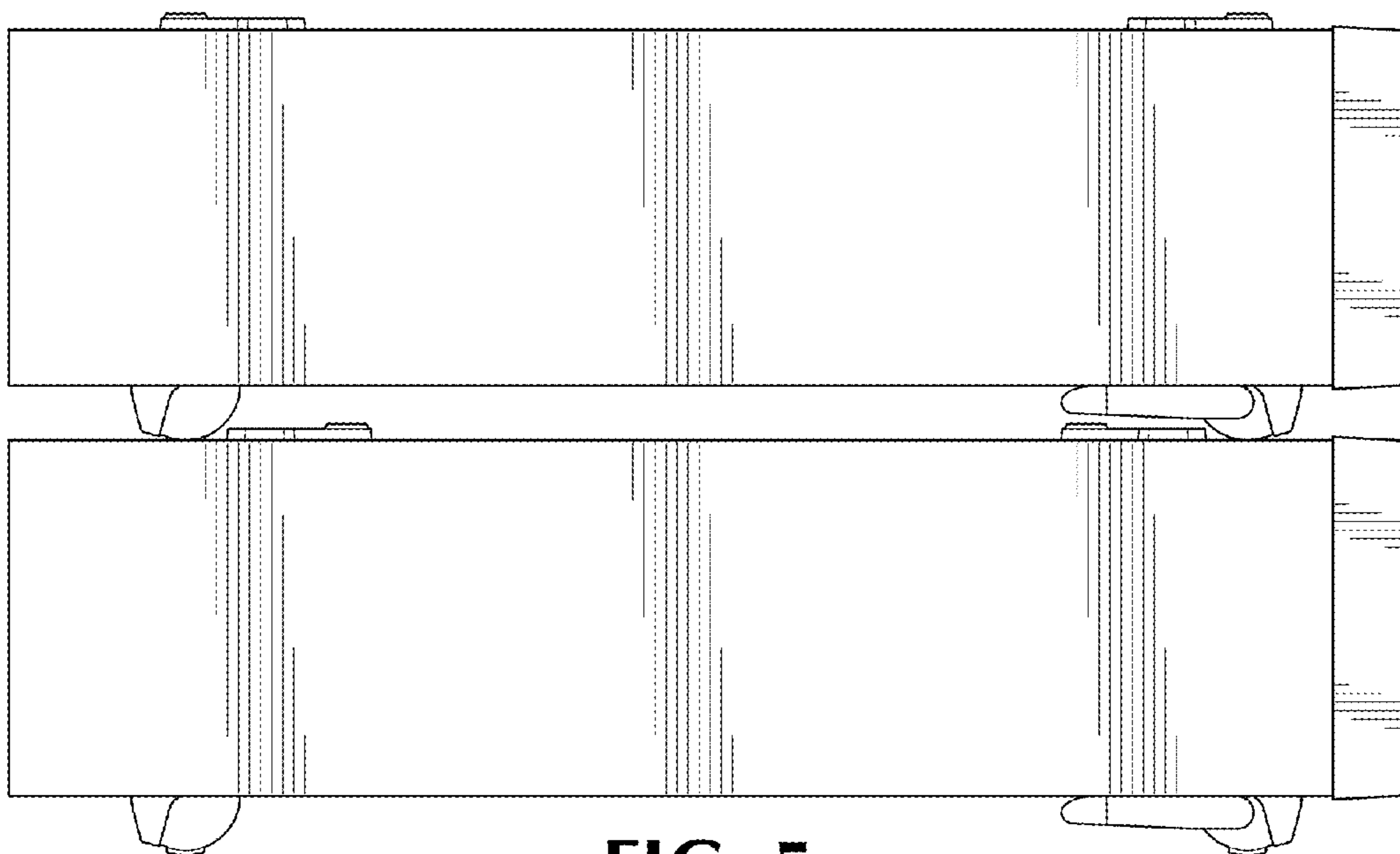

FIG. 5

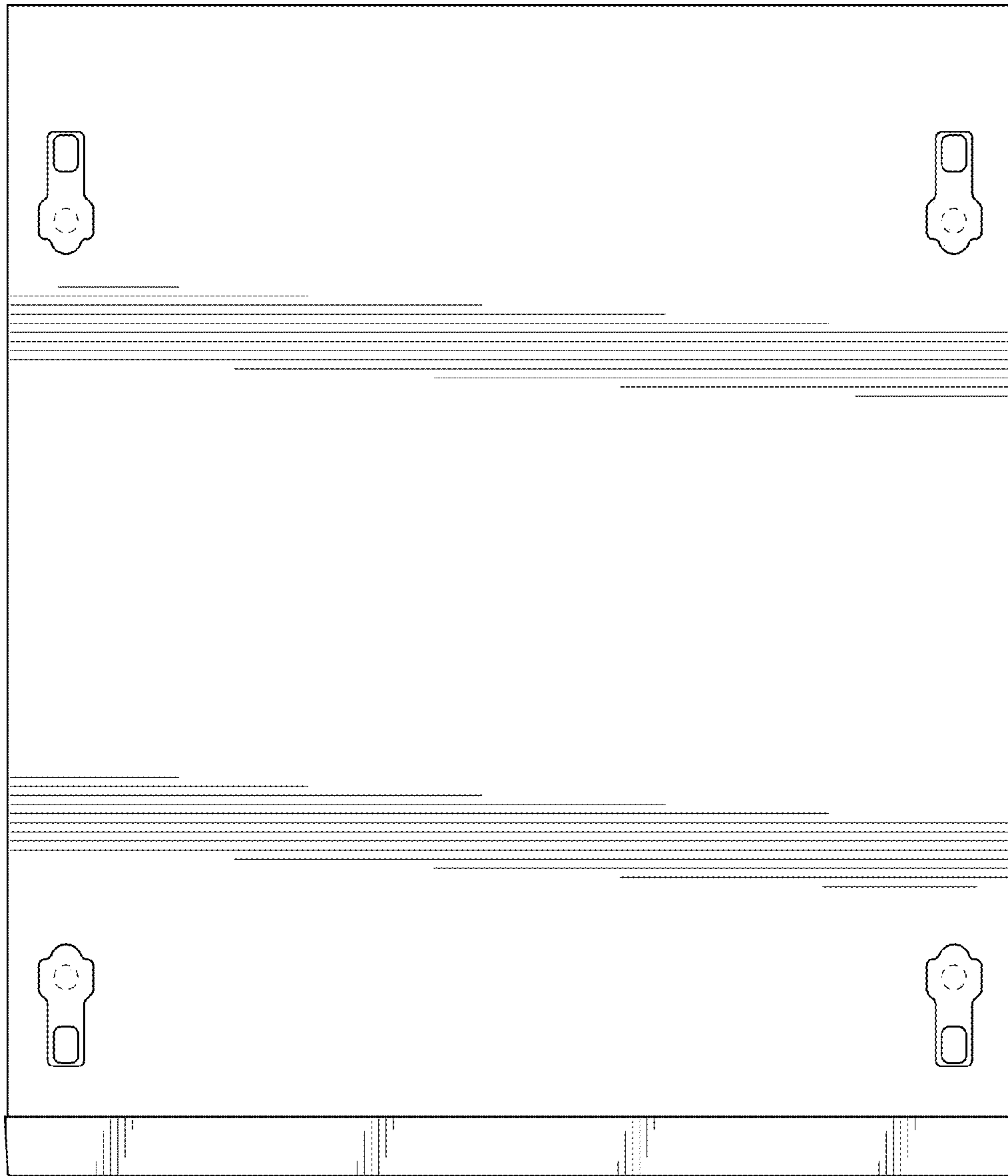

FIG. 6

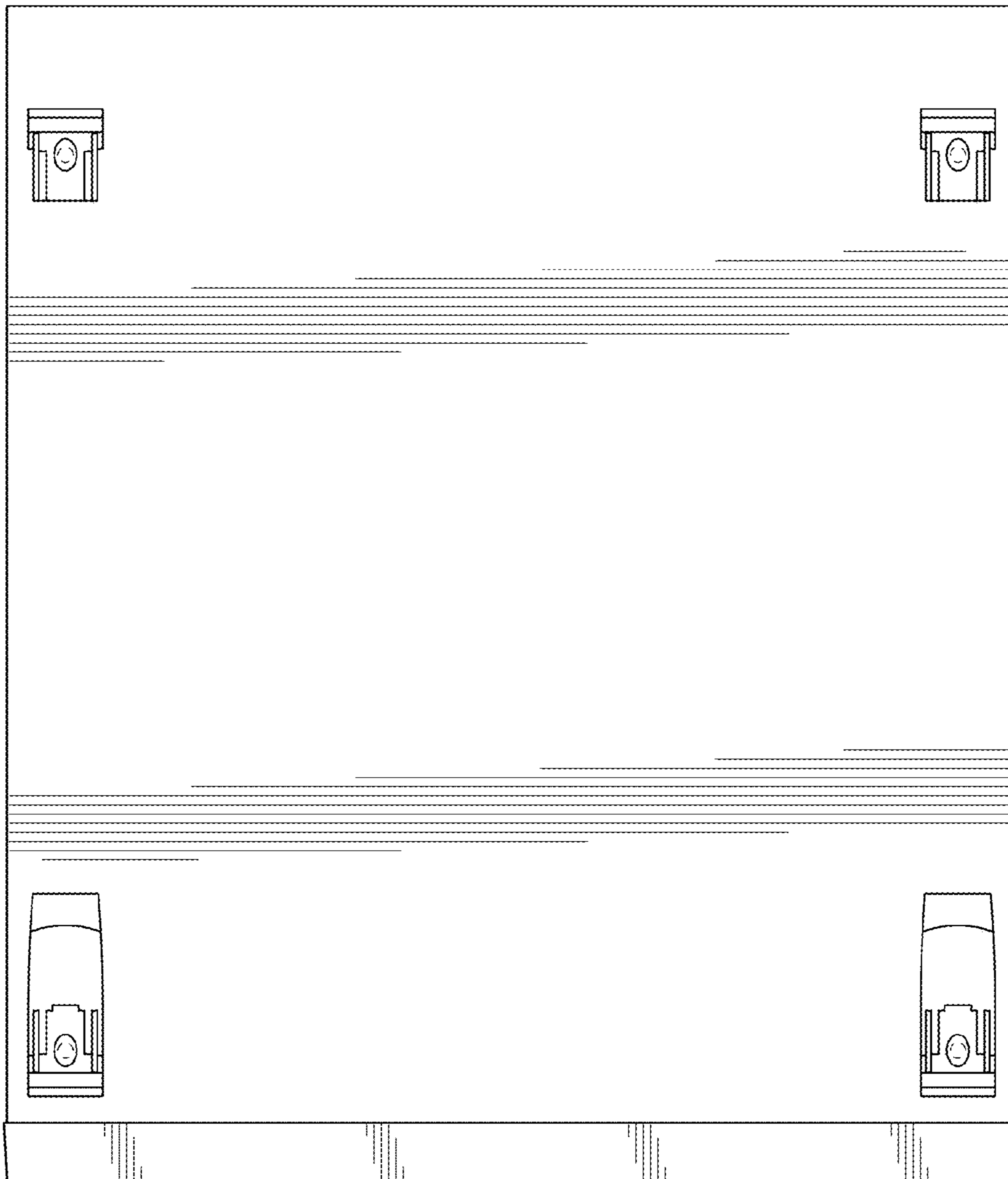

FIG. 7

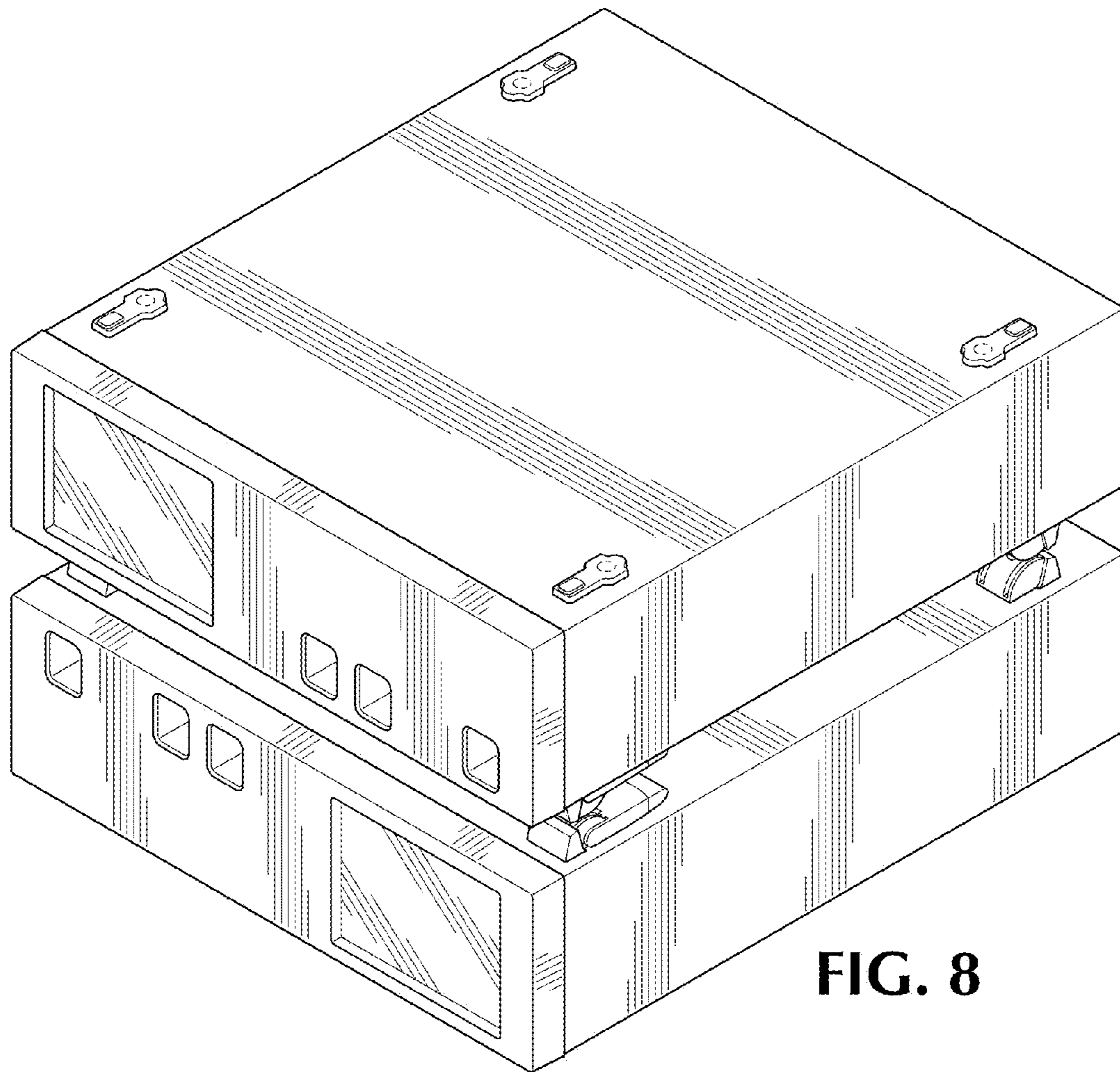

FIG. 8

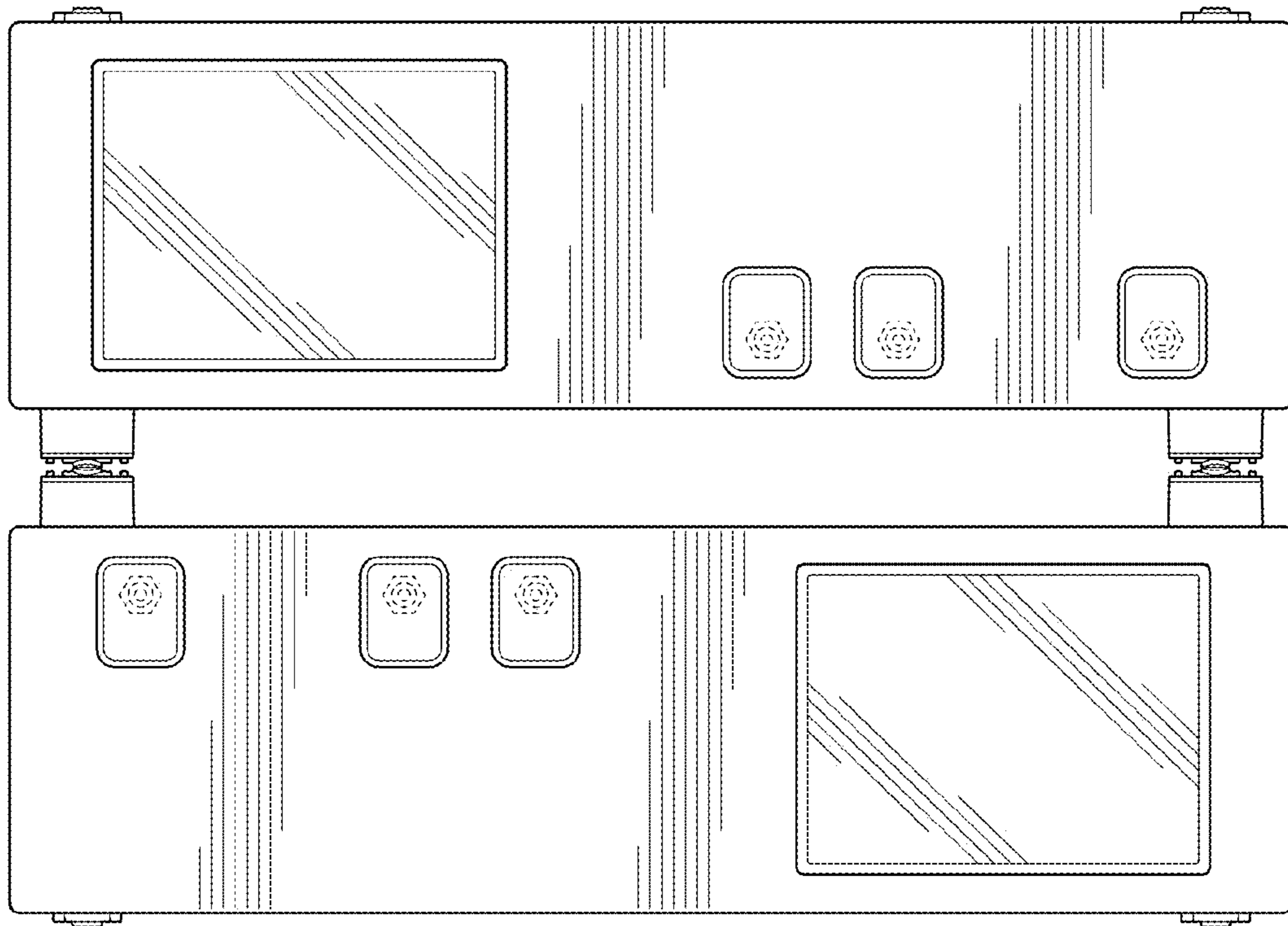

FIG. 9

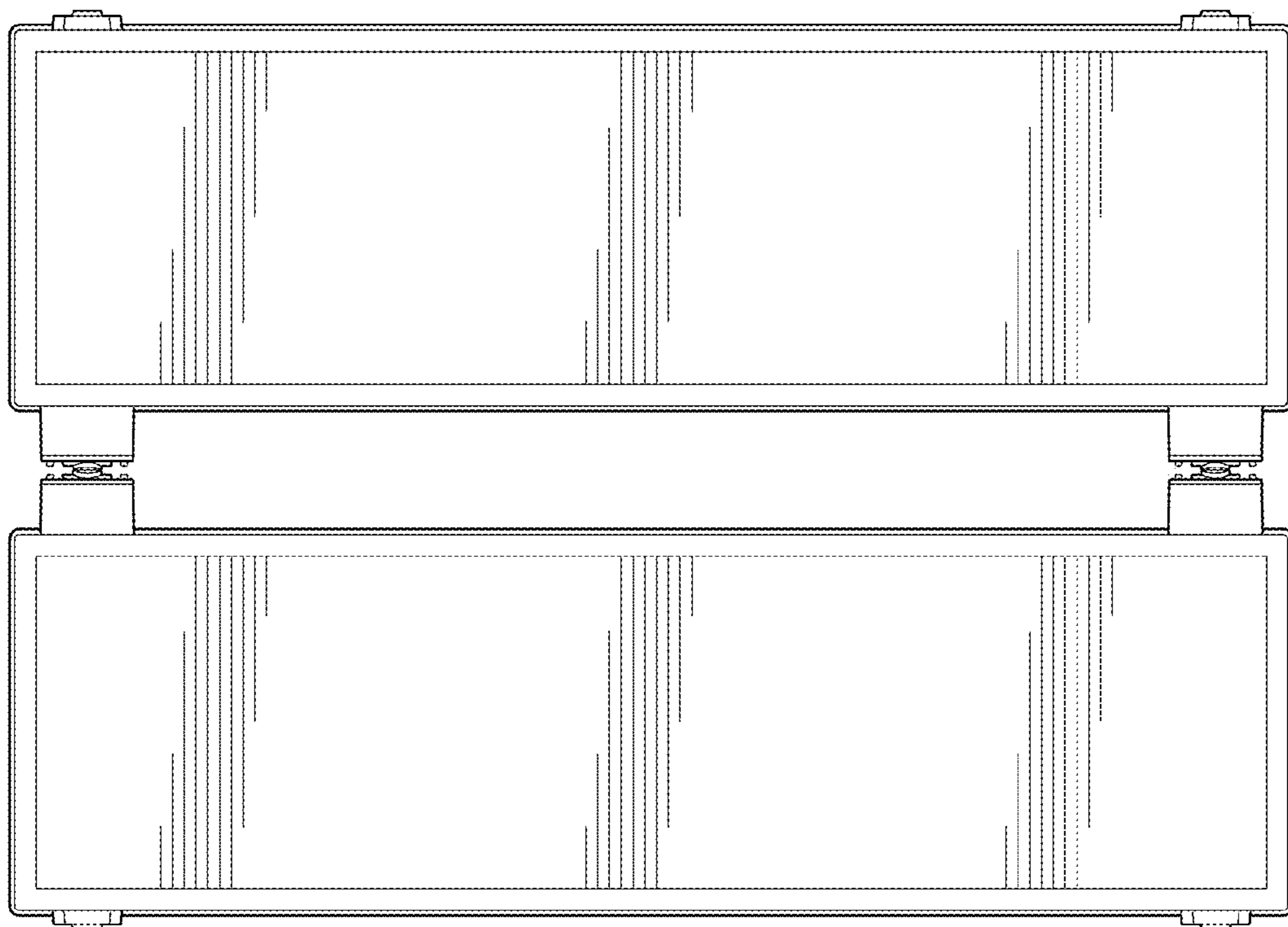

FIG. 10

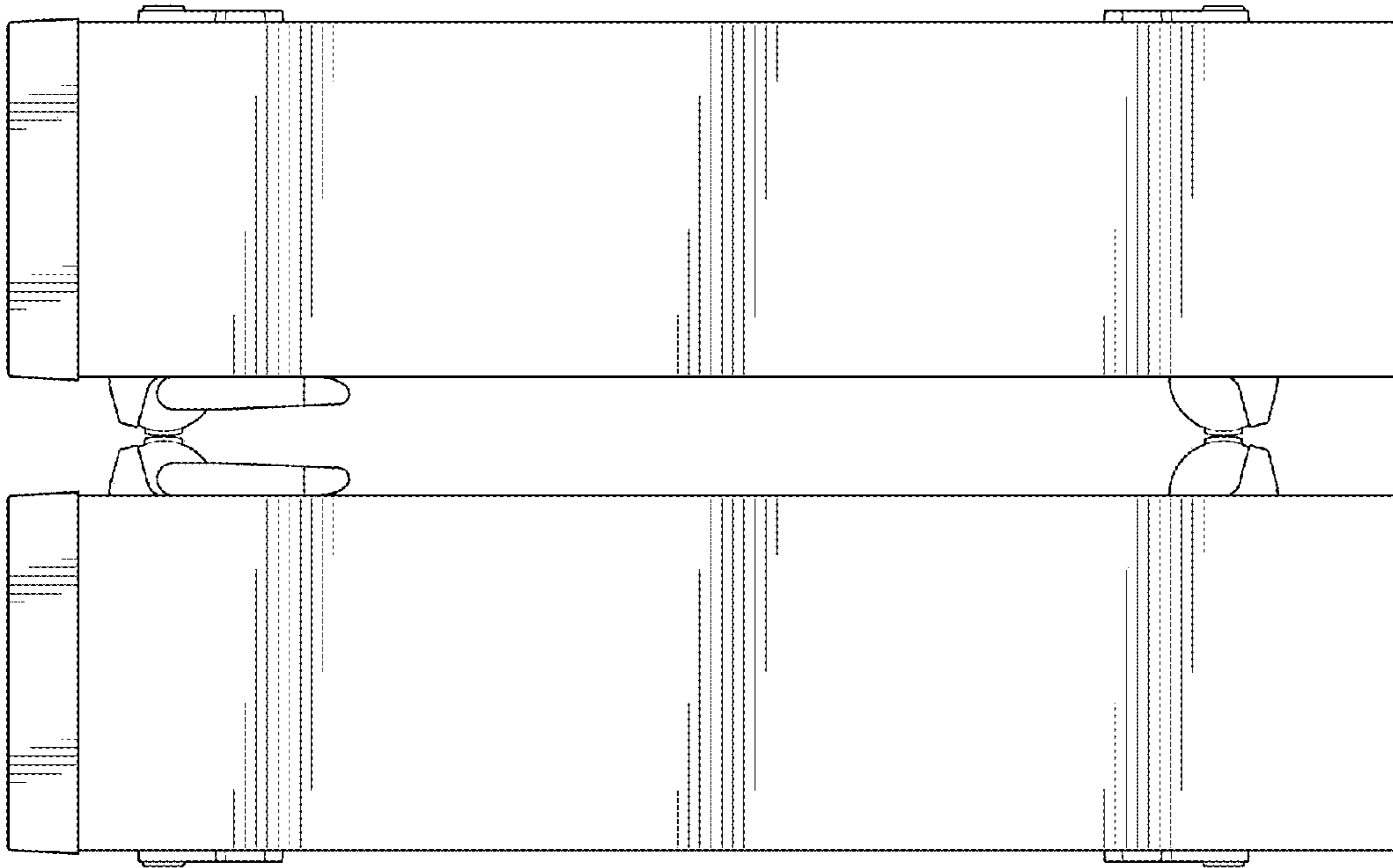

FIG. 11

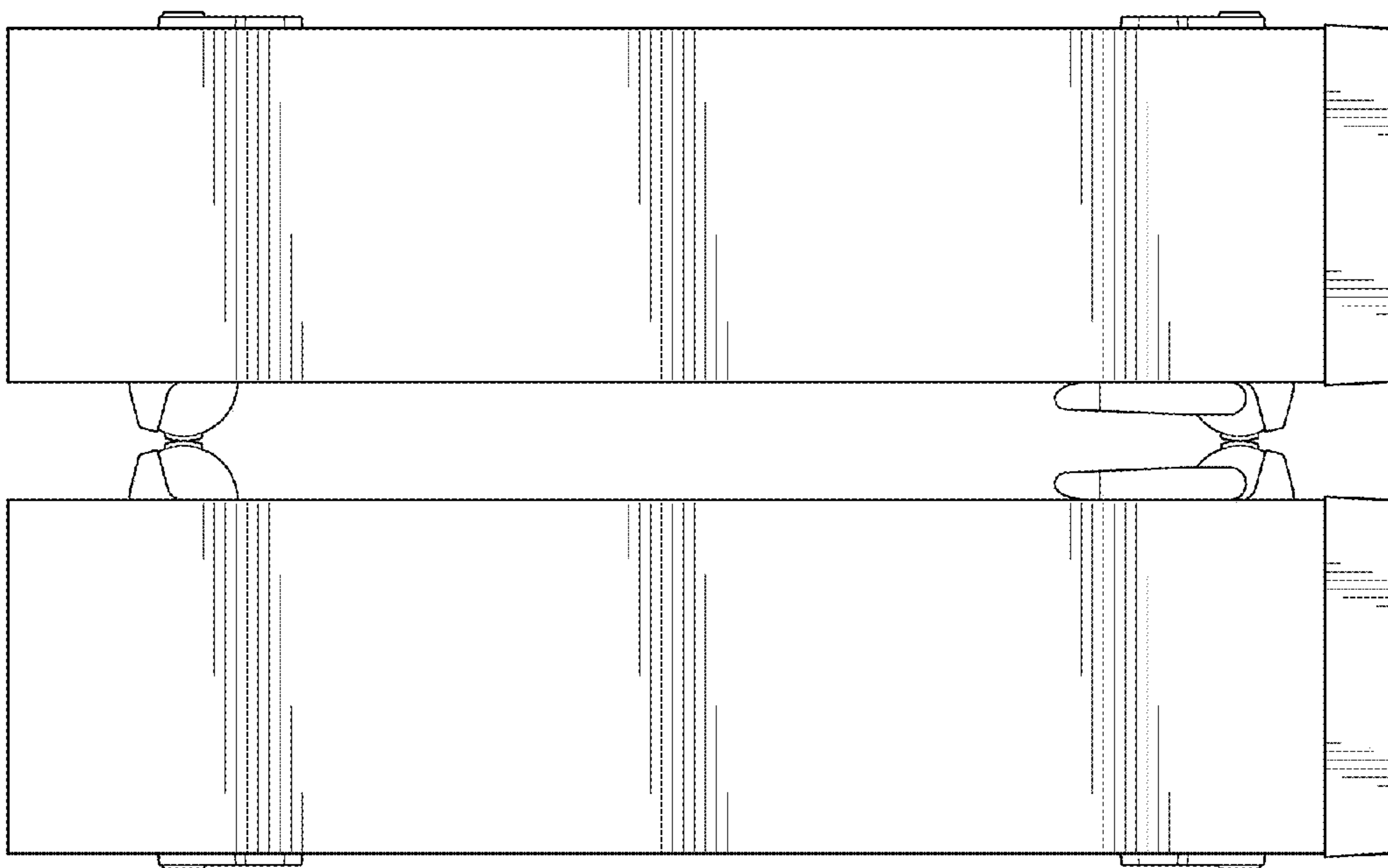

FIG. 12

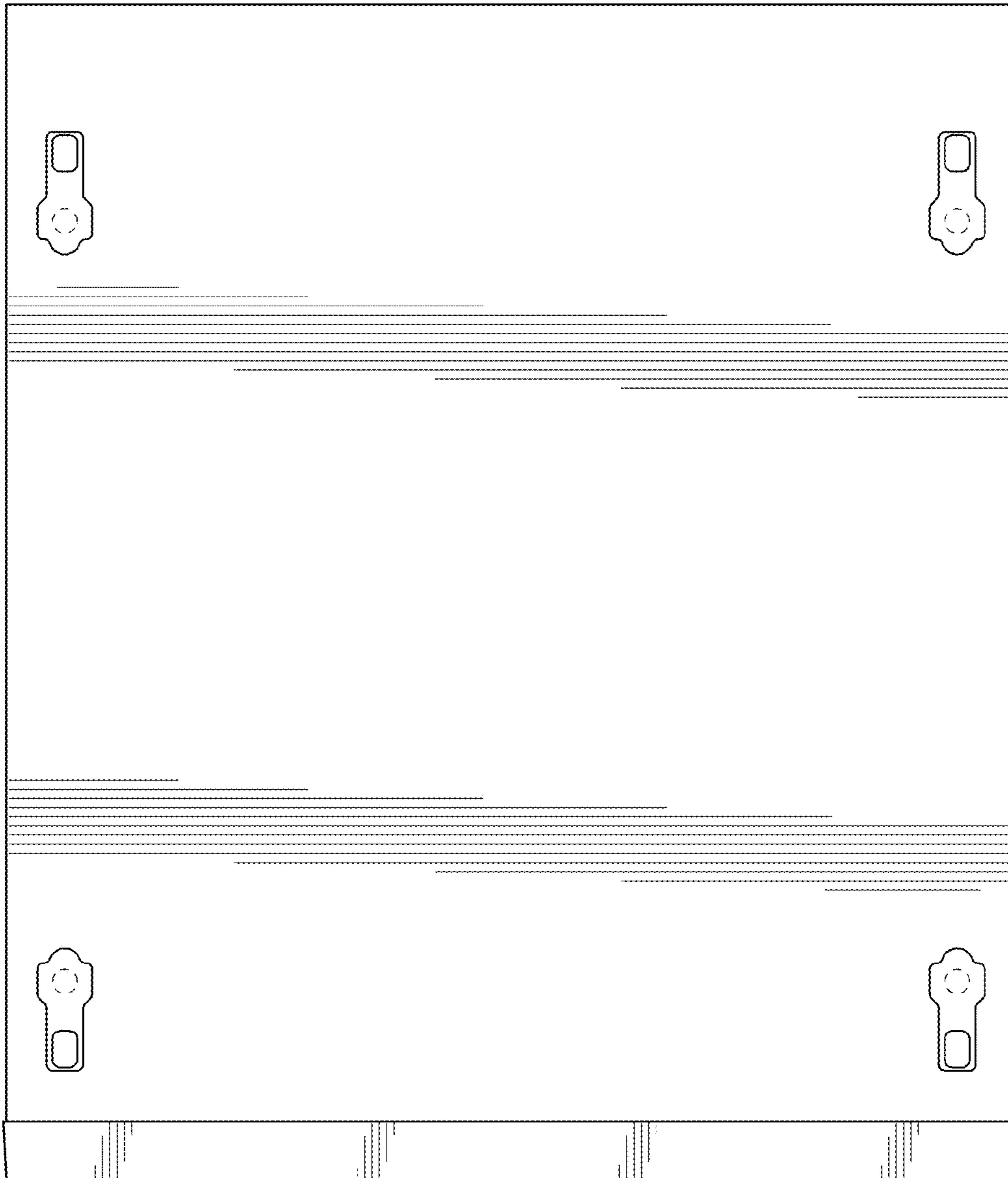

FIG. 13

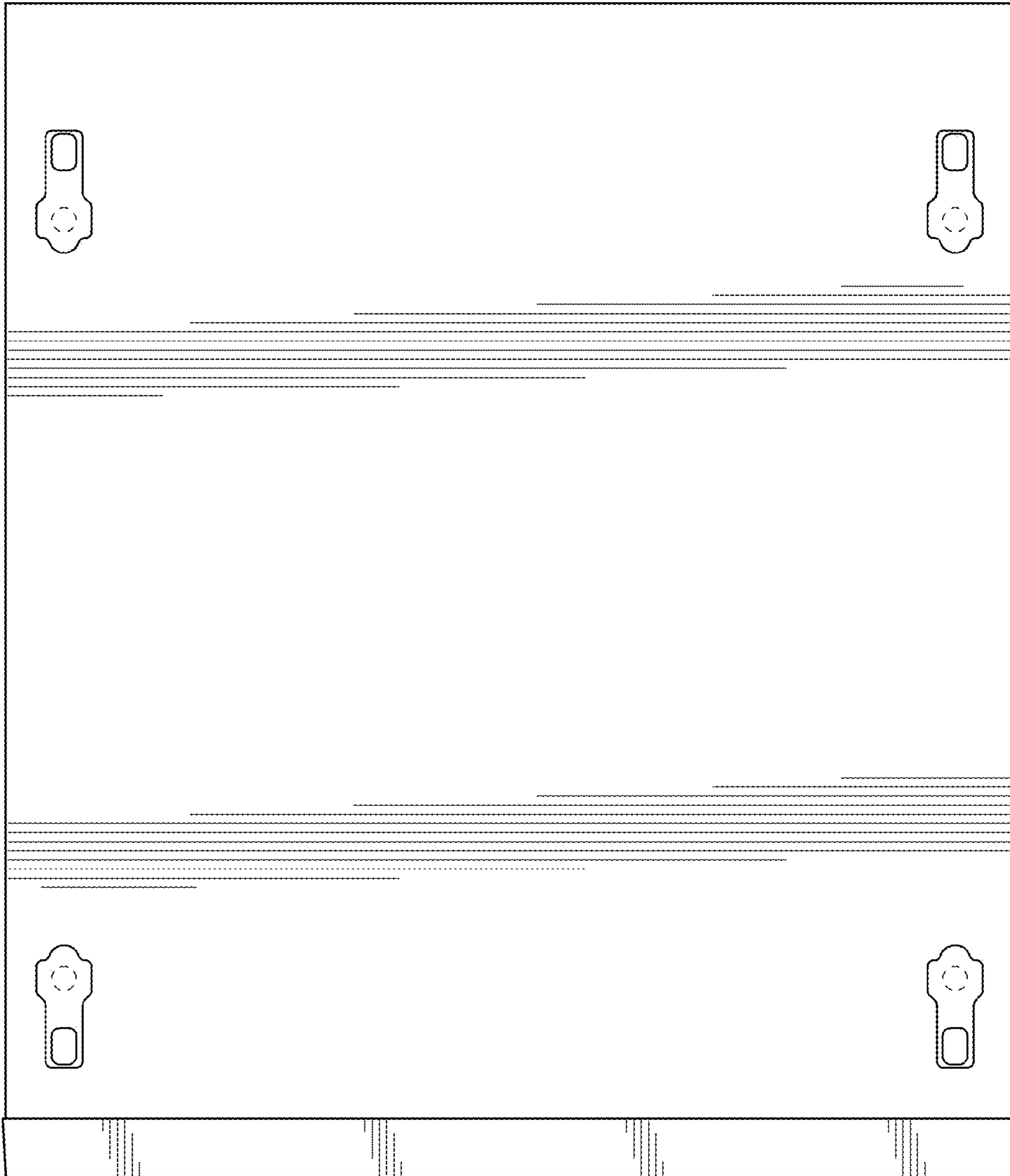

FIG. 14

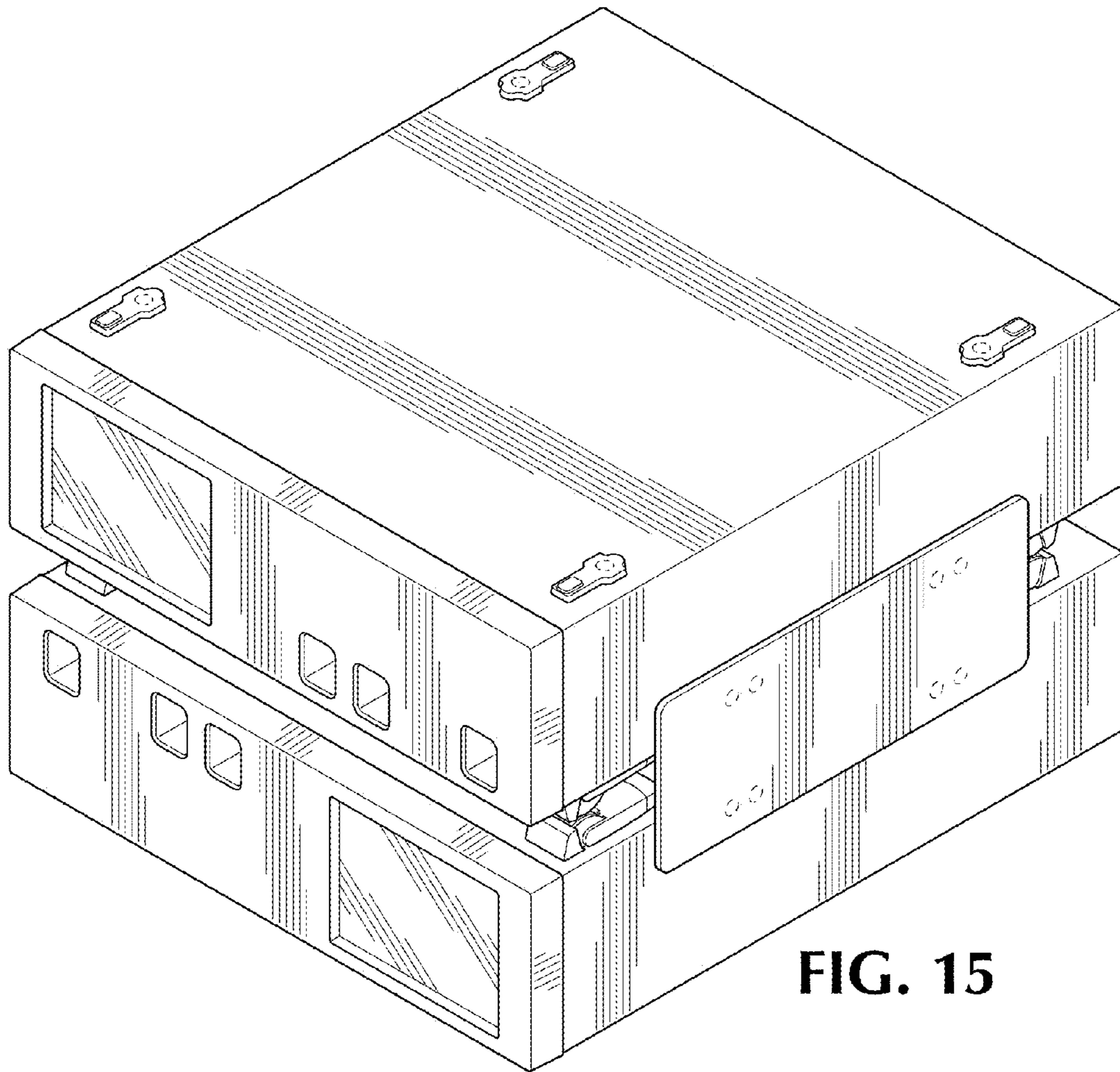

FIG. 15

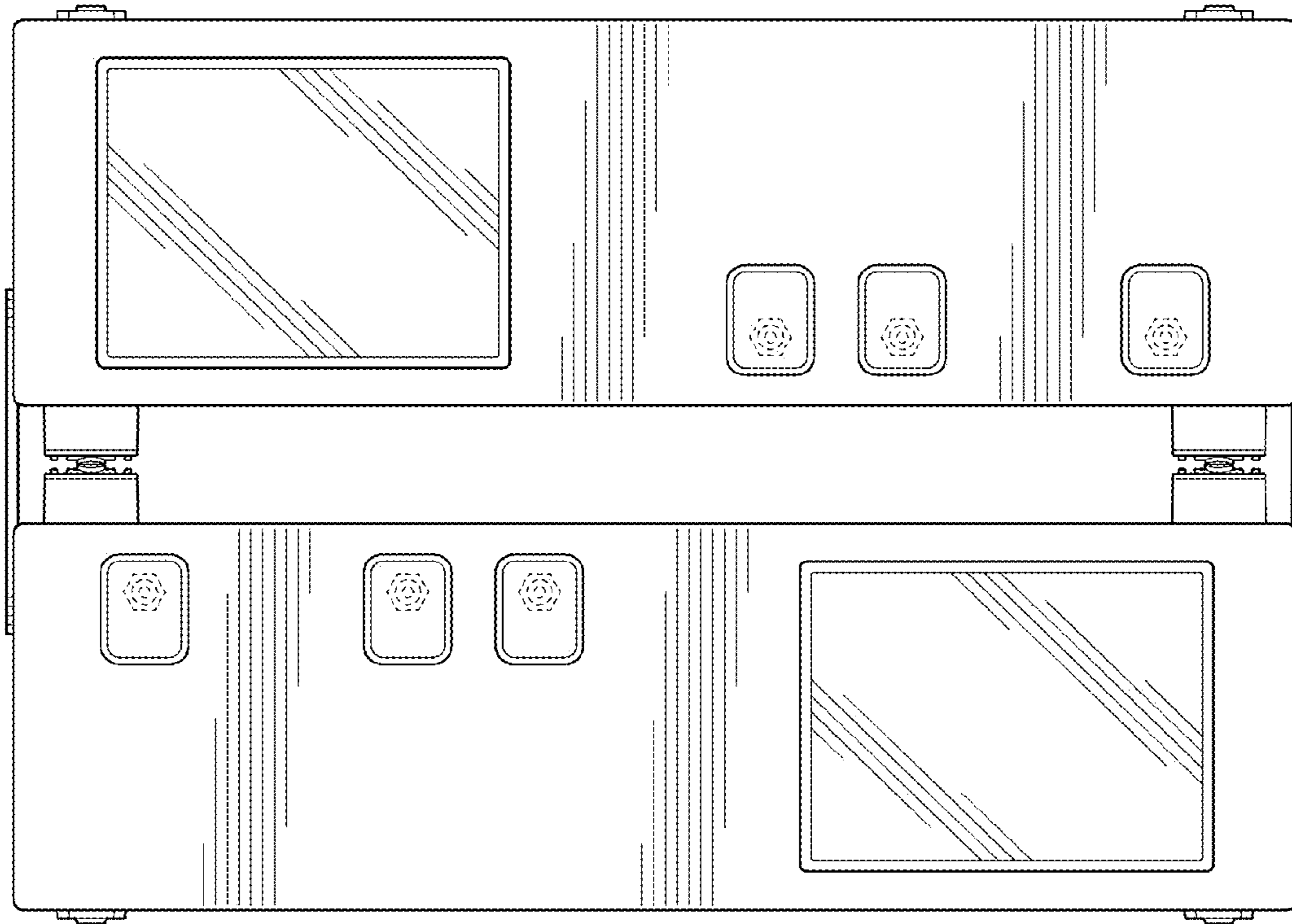

FIG. 16

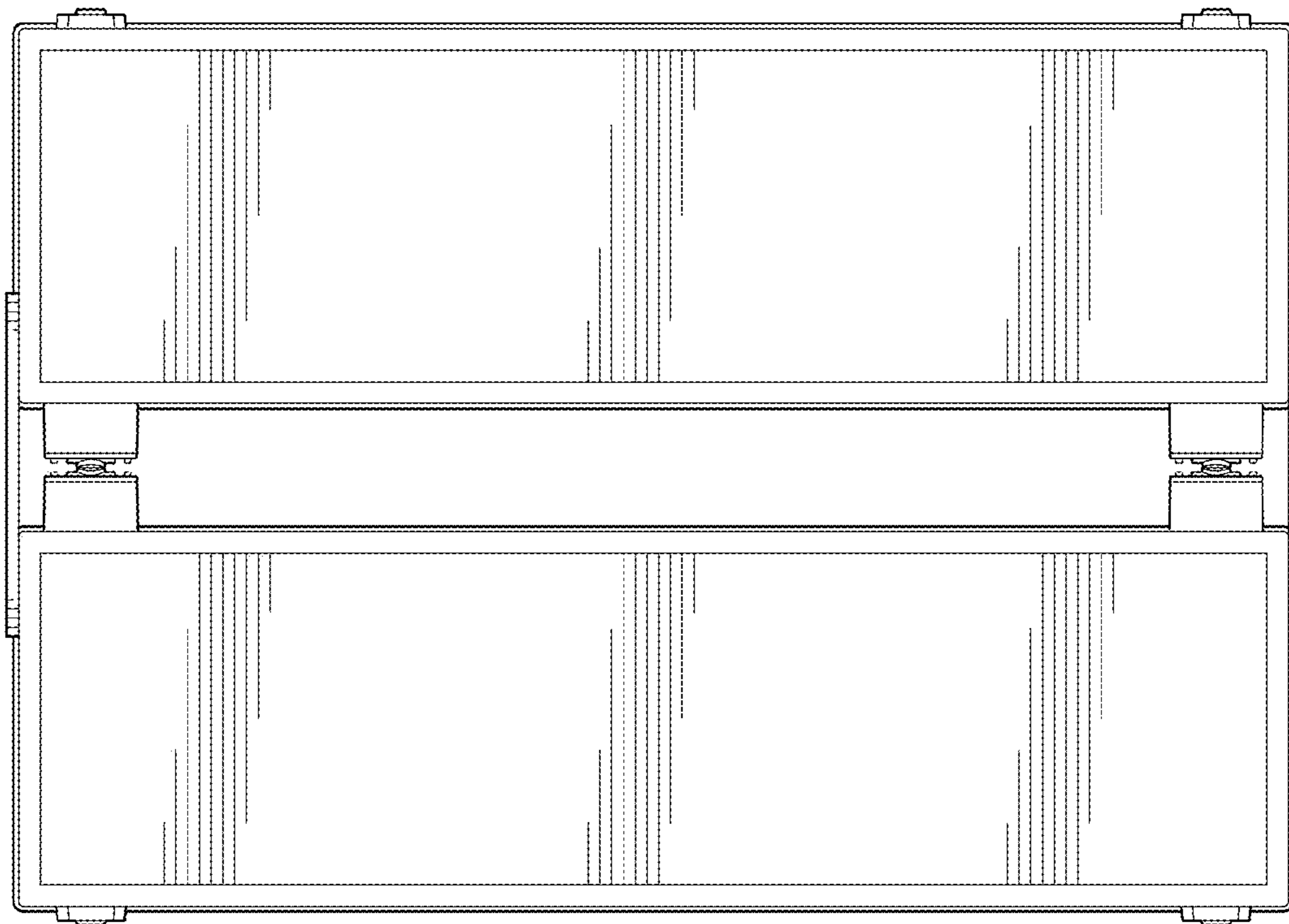

FIG. 17

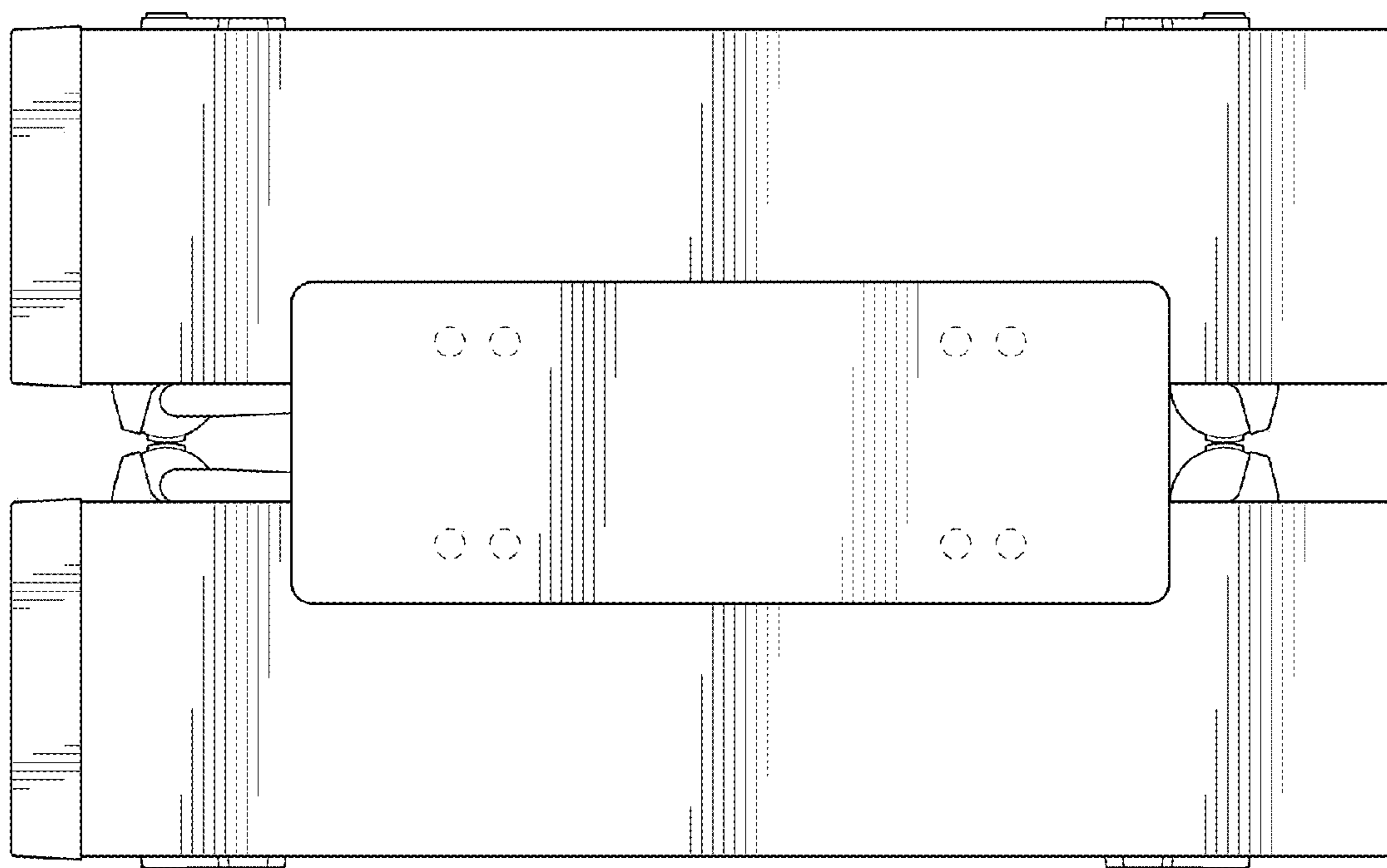

FIG. 18

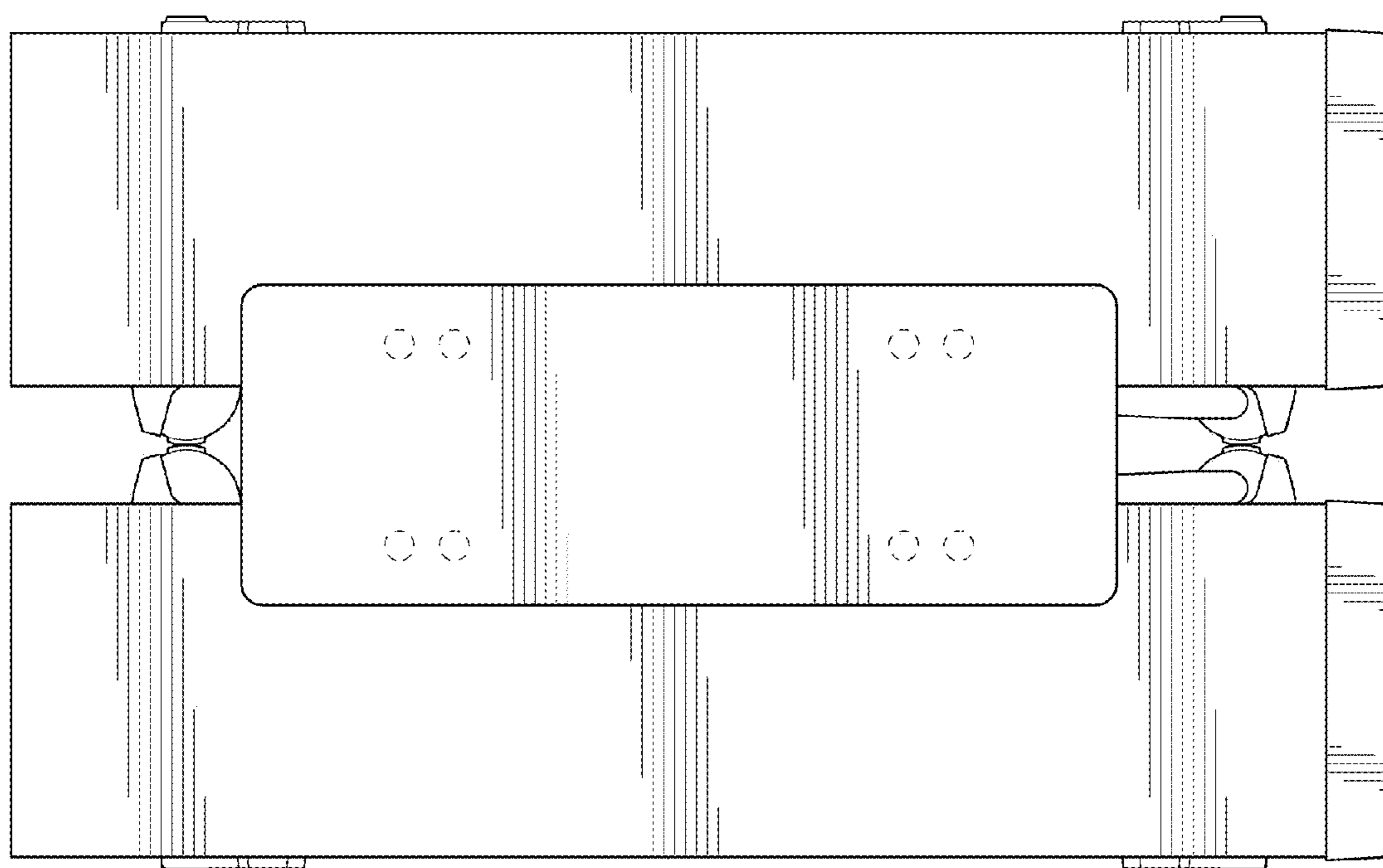

FIG. 19

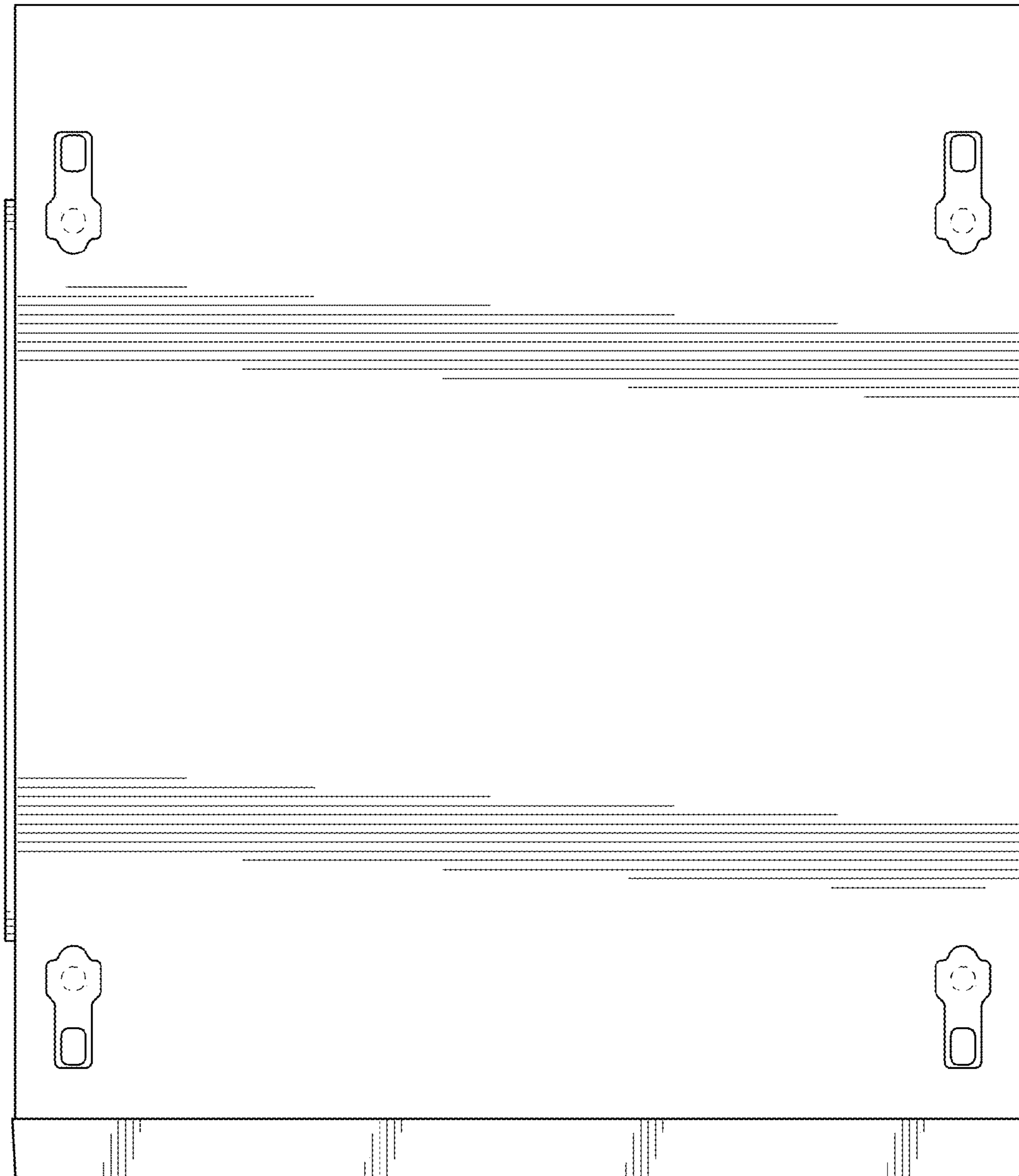

FIG. 20

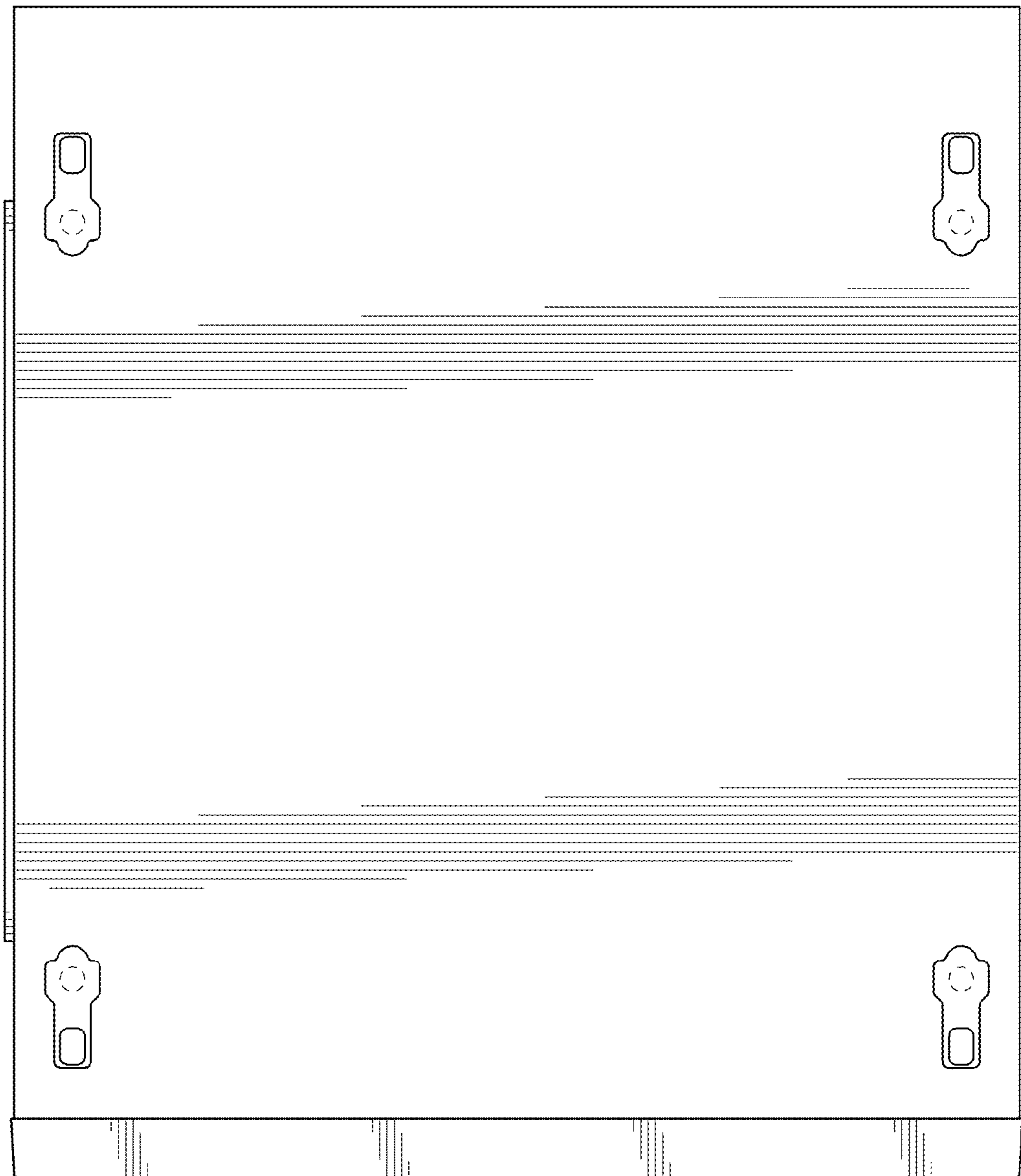

FIG. 21

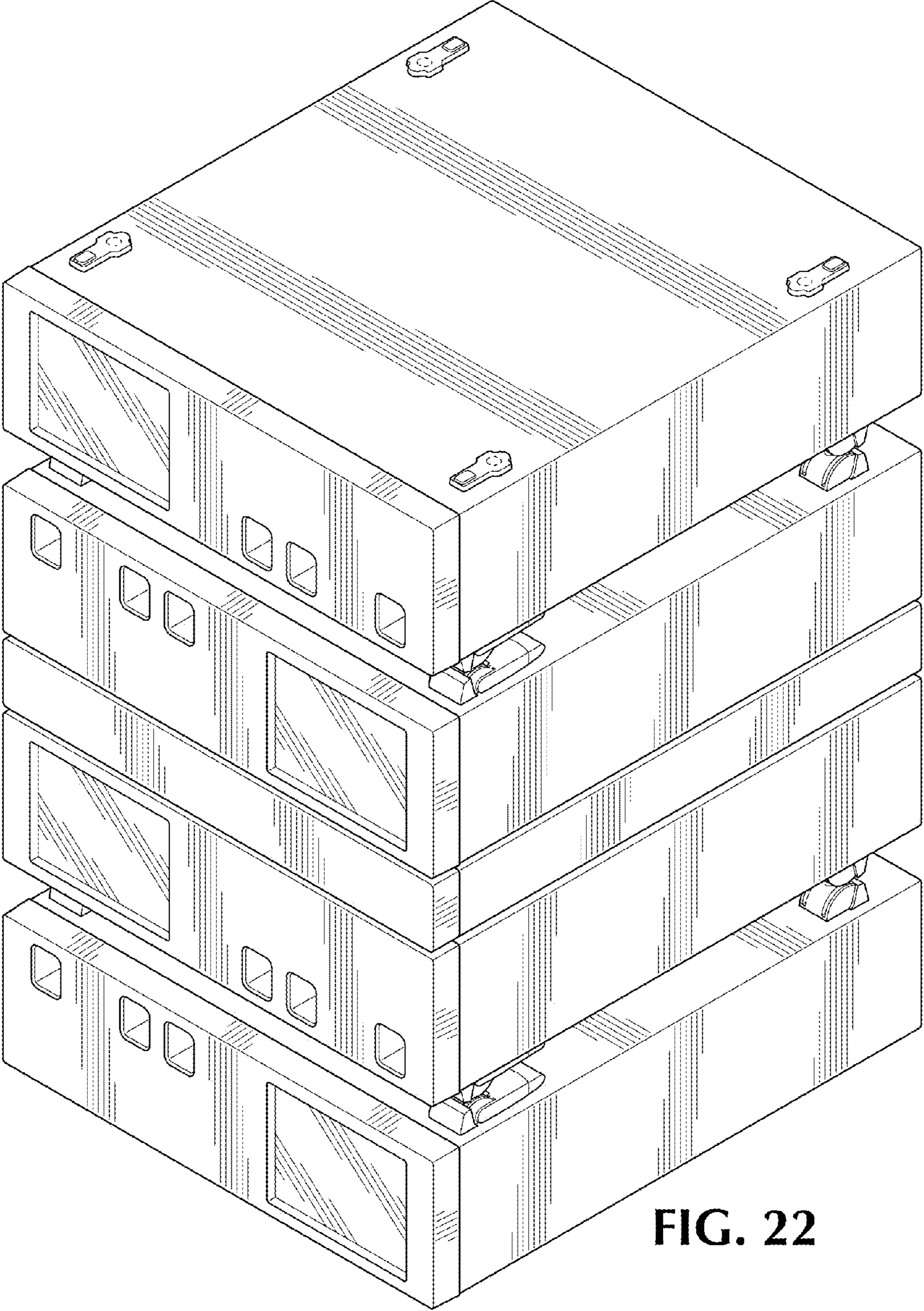

FIG. 22

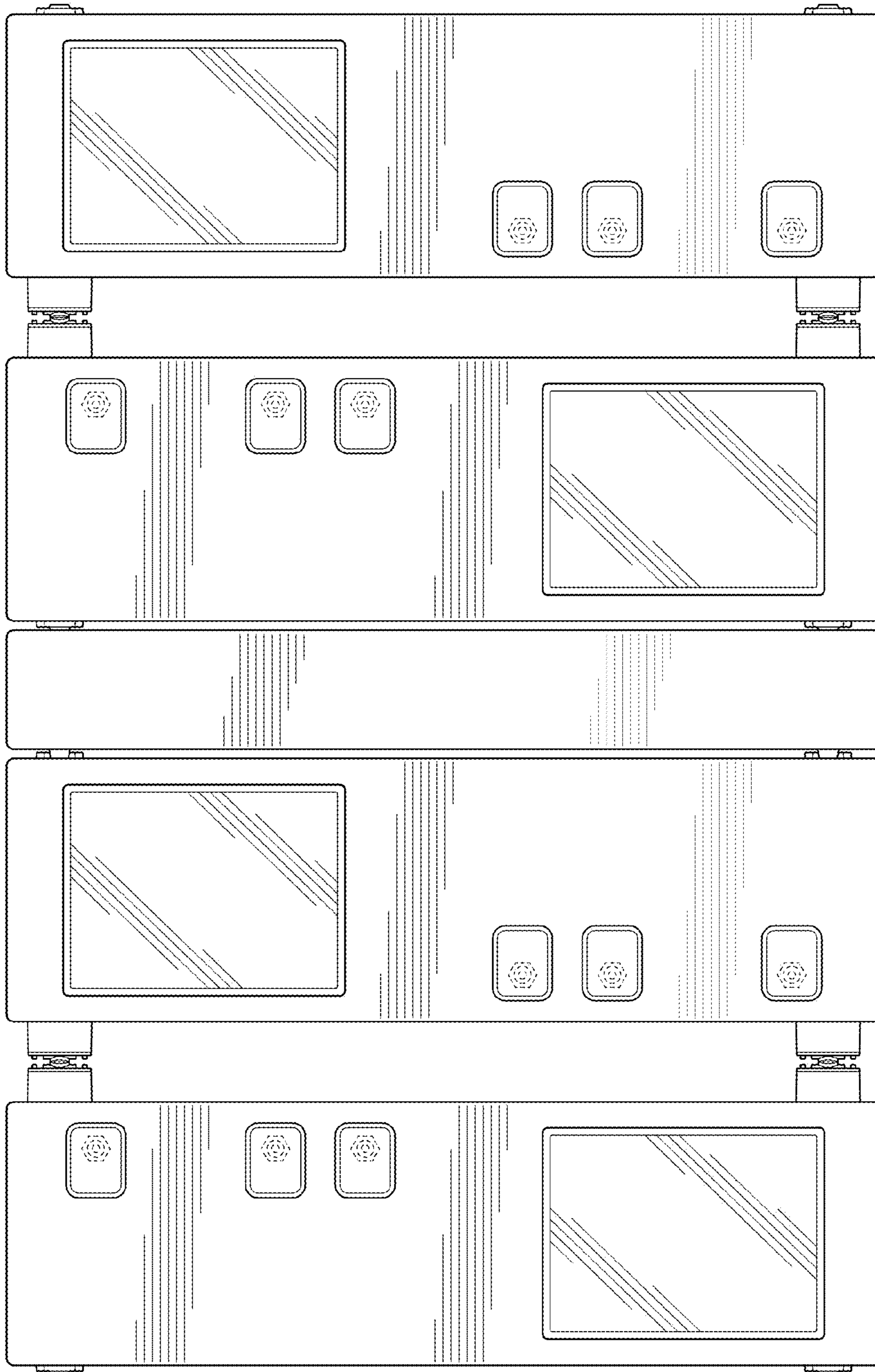

FIG. 23

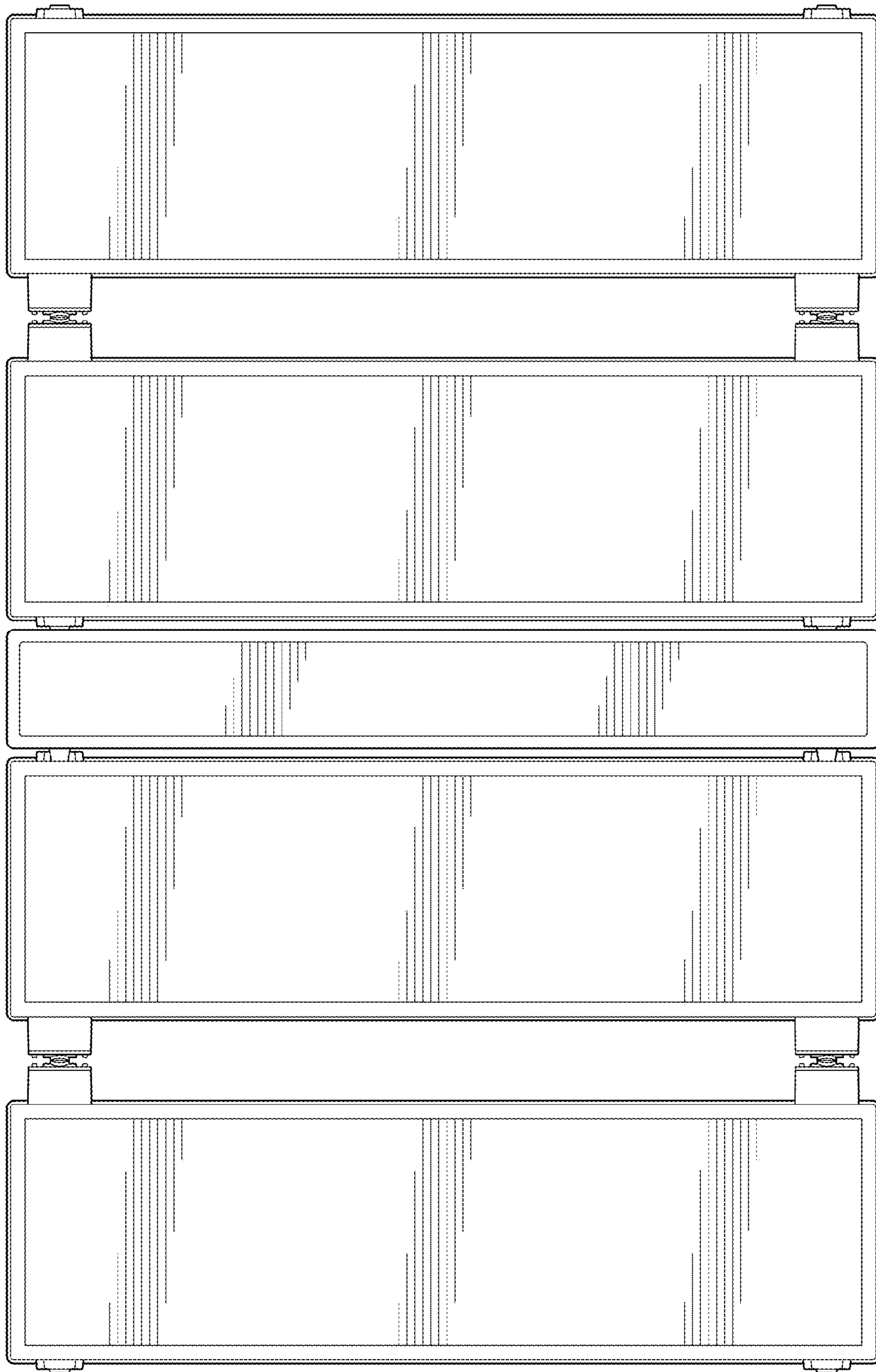

FIG. 24

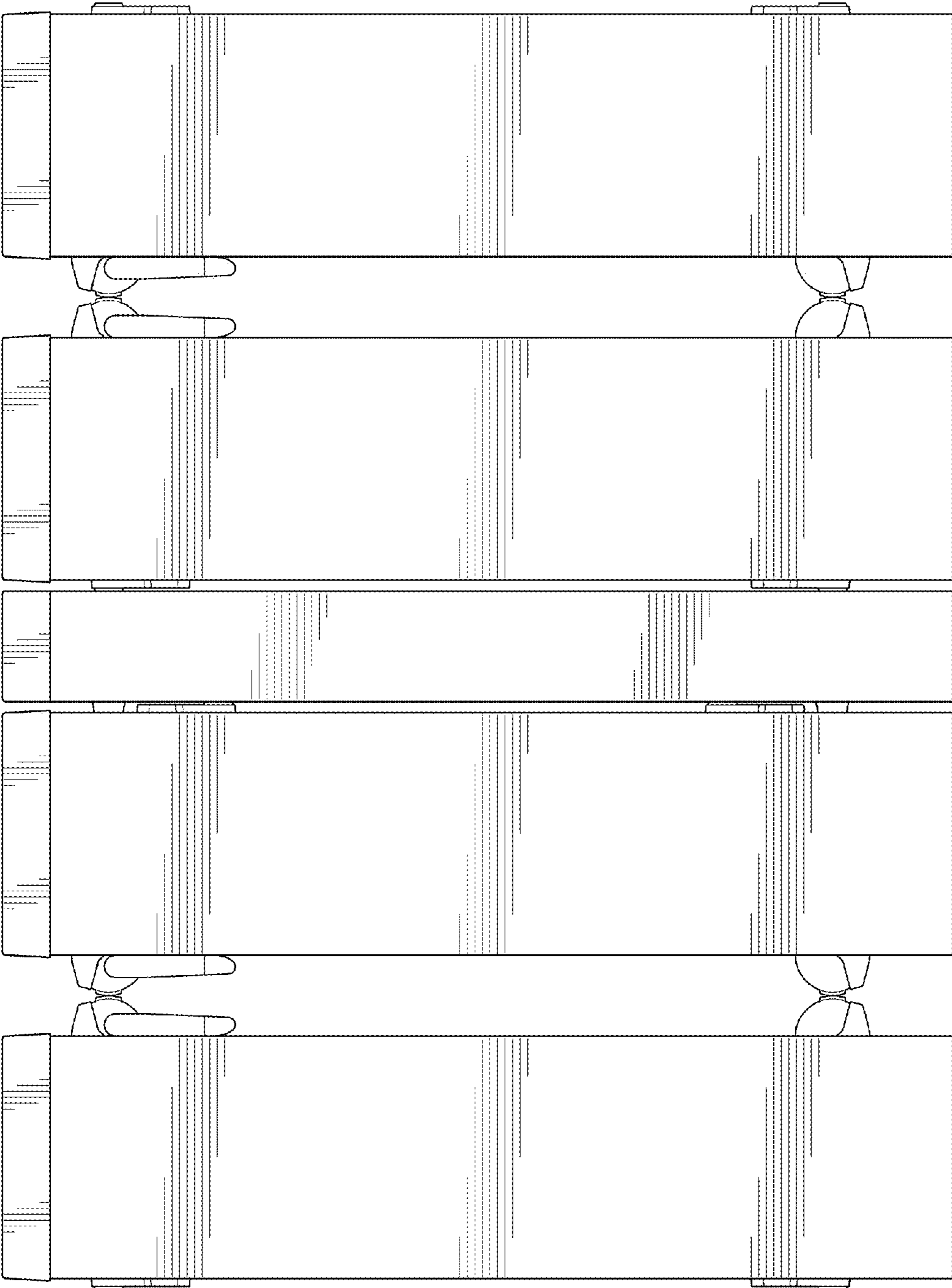

FIG. 25

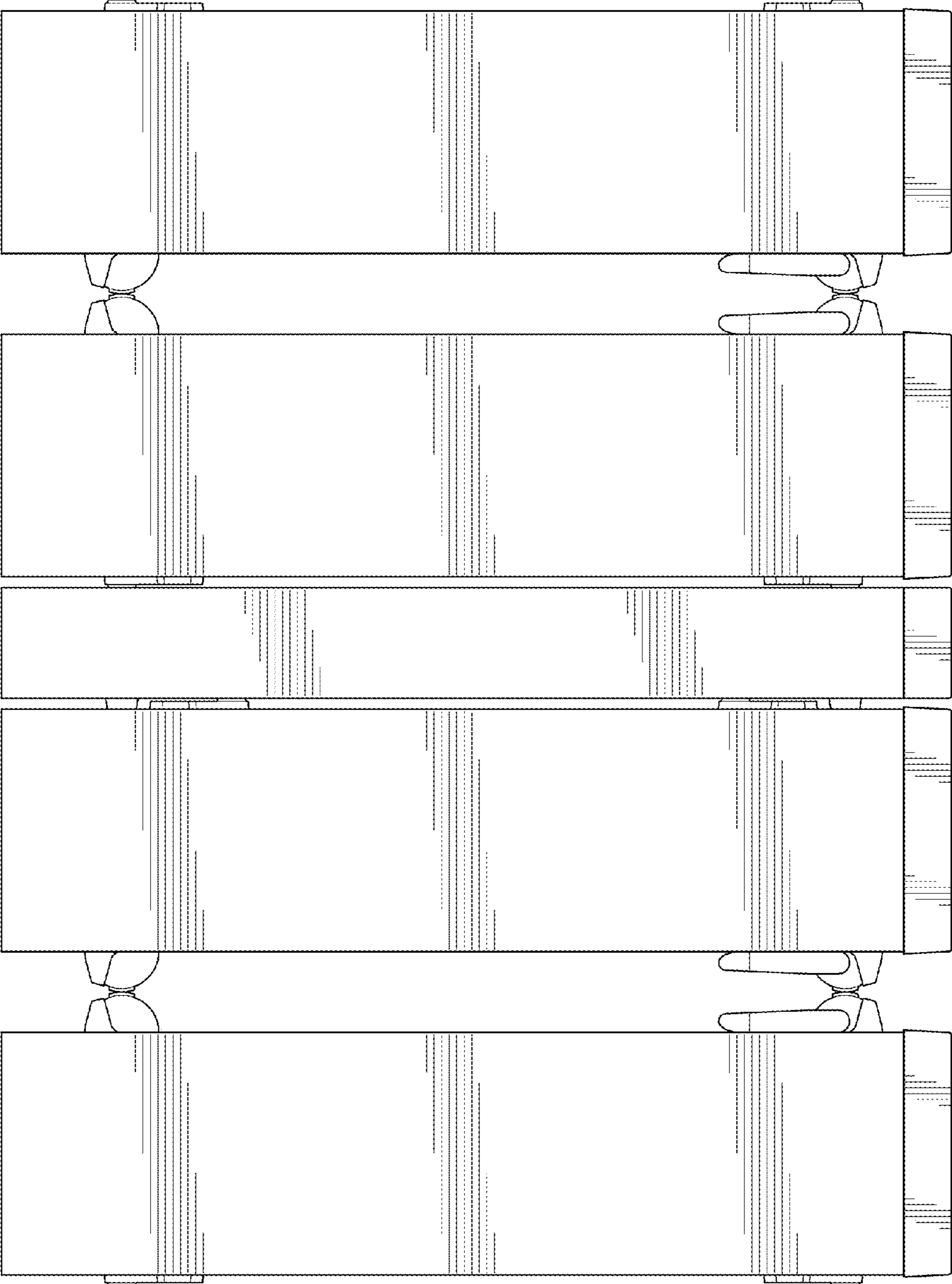

FIG. 26

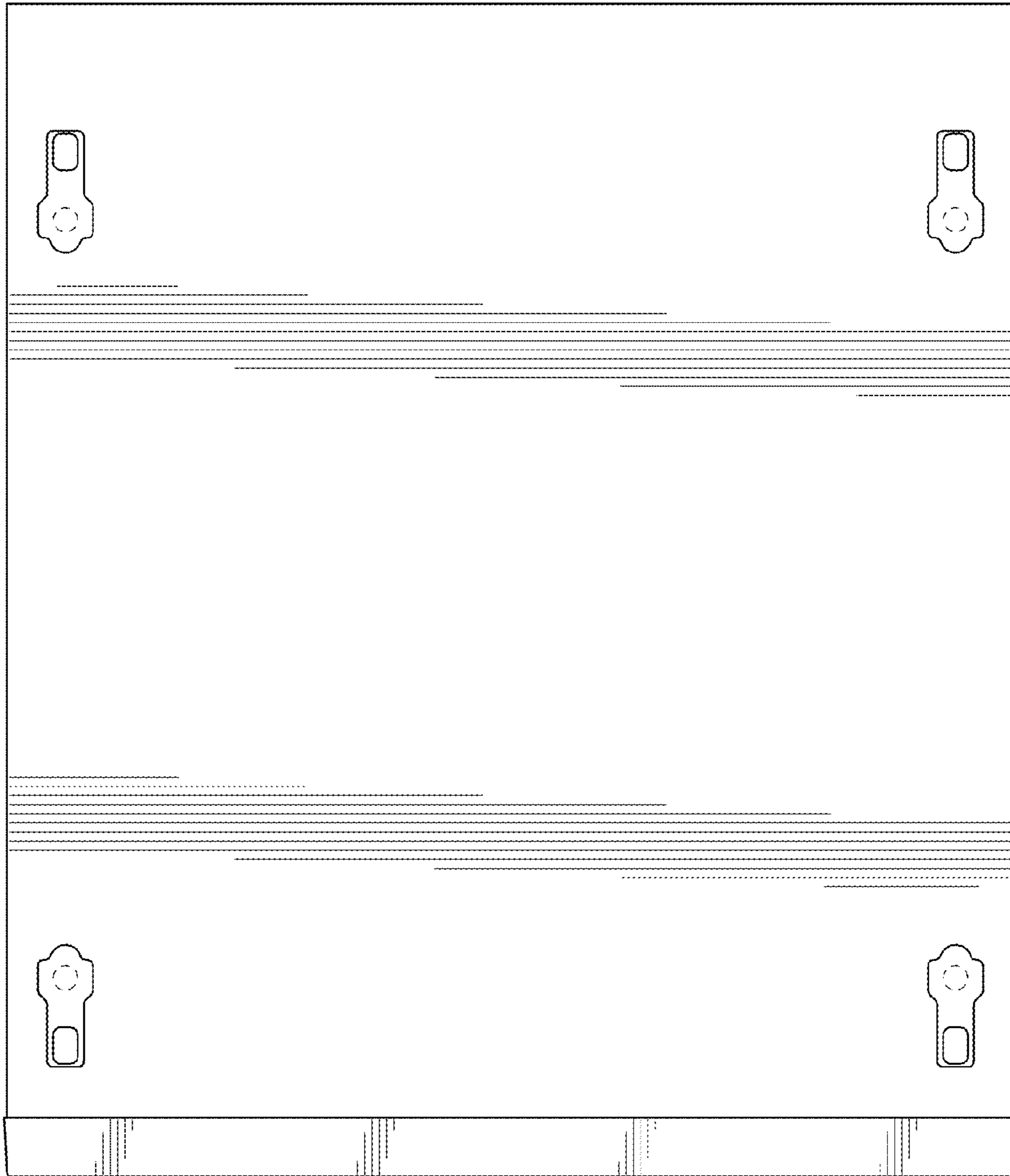

FIG. 27

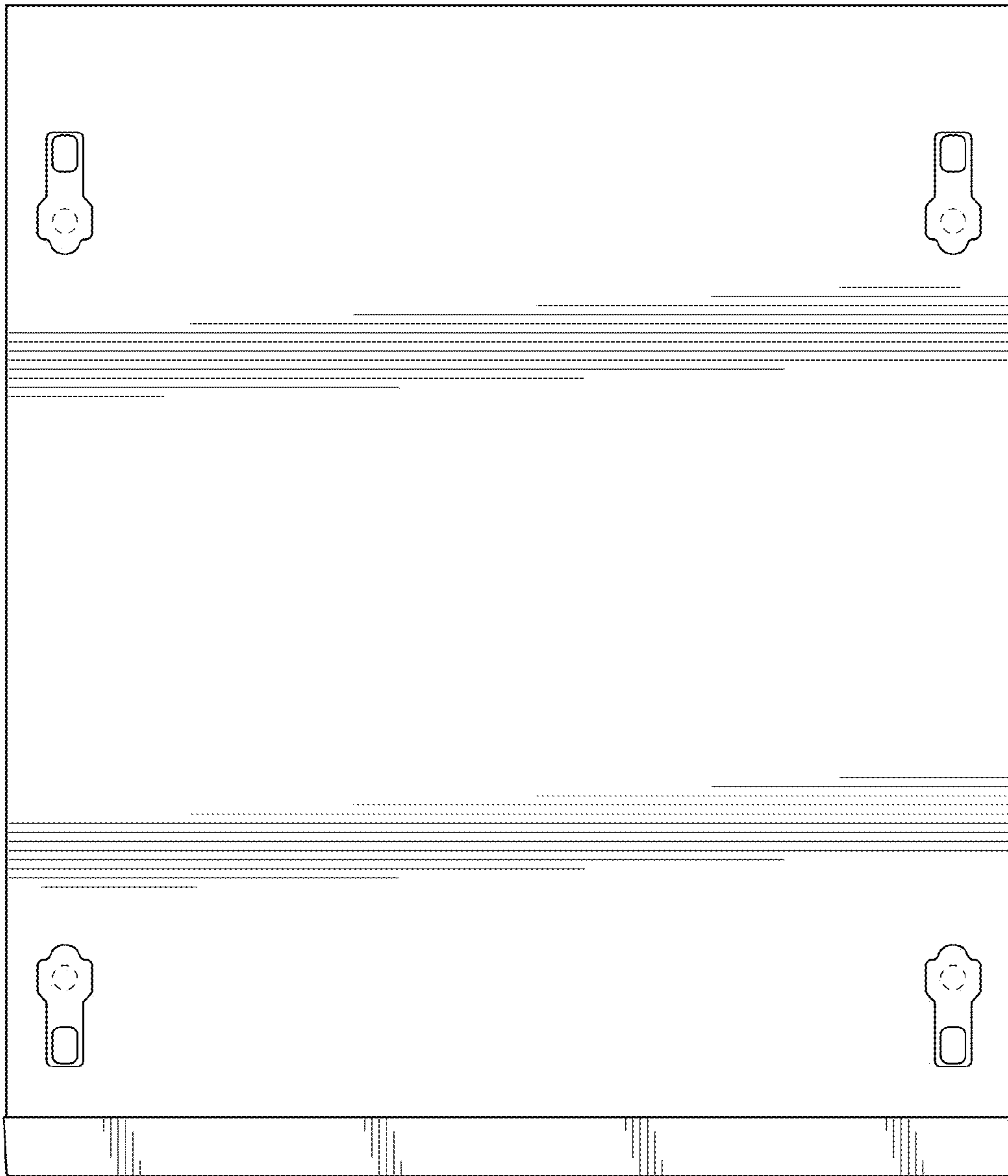

FIG. 28

UNITED STATES PATENT AND TRADEMARK OFFICE
CERTIFICATE OF CORRECTION

PATENT NO. : D776,106 S
APPLICATION NO. : 29/539197
DATED : January 10, 2017
INVENTOR(S) : Marc A. Gessford et al.

Page 1 of 1

It is certified that error appears in the above-identified patent and that said Letters Patent is hereby corrected as shown below:

On the Title Page

On page 2, left-hand Column, Line 1, please replace “upside flown” with “upside down”.

On page 2, left-hand Column, Line 2, please replace “fiat” with “flat”.

Signed and Sealed this
Nineteenth Day of September, 2017



Joseph Matal
*Performing the Functions and Duties of the
Under Secretary of Commerce for Intellectual Property and
Director of the United States Patent and Trademark Office*