



US00D776047S

(12) **United States Design Patent** (10) **Patent No.:** **US D776,047 S**
Matsumoto (45) **Date of Patent:** **** Jan. 10, 2017**

(54) **SPIKE PIN FOR AUTOMOBILE TIRE**

D706,709 S * 6/2014 Matsumoto D12/608
D708,567 S * 7/2014 Matsumoto D12/608
2013/0000807 A1* 1/2013 Pons B60C 11/1643
152/210

(71) Applicant: **THE YOKOHAMA RUBBER CO., LTD.**, Minato-ku, Tokyo (JP)

(72) Inventor: **Kenichi Matsumoto**, Hiratsuka (JP)

(73) Assignee: **THE YOKOHAMA RUBBER CO., LTD.**, Minato-ku, Tokyo (JP)

(**) Term: **15 Years**

(21) Appl. No.: **29/526,860**

(22) Filed: **May 13, 2015**

(30) **Foreign Application Priority Data**

Nov. 14, 2014 (JP) 2014-025498

(51) **LOC (10) Cl.** **12-15**

(52) **U.S. Cl.**
USPC **D12/608**

(58) **Field of Classification Search**
USPC D12/500, 501, 544, 579, 604, 606-608;
152/210, 243
CPC B60C 27/08; B60C 11/1675
See application file for complete search history.

(56) **References Cited**

U.S. PATENT DOCUMENTS

3,837,386 A * 9/1974 Lejeune B60C 11/16
152/210
D452,212 S * 12/2001 Davidoski D12/604
D550,611 S * 9/2007 Liukkula D12/608
D551,614 S * 9/2007 Liukkula D12/608
D584,979 S * 1/2009 Pirhonen D12/608
D608,233 S * 1/2010 Pirhonen D12/608

OTHER PUBLICATIONS

Tire Rack. Get the Most Life Out of Your Studdable Winter/Snow Tires. Oct. 9, 2013 [earliest online date], [site visited Jul. 18, 2016]. Available from Internet, <URL:http://blog.tirerack.com/blog/yokohama-s-drives-on-pch-1/get-the-most-life-out-of-your-studdable-winter-snow-tires>.*

* cited by examiner

Primary Examiner — Robert M Spear
Assistant Examiner — Darcey E Heflin
(74) *Attorney, Agent, or Firm* — Banner & Witcoff, Ltd.

(57) **CLAIM**

The ornamental design for a spike pin for automobile tire, as shown and described.

DESCRIPTION

FIG. 1 is a perspective view of a spike pin for an automobile tire showing my new design;
FIG. 2 is a front view thereof;
FIG. 3 is a right side view thereof;
FIG. 4 is a top view thereof;
FIG. 5 is a bottom view thereof;
FIG. 6 is a cross sectional view taken along lines 6-6 shown in FIG. 2; and,
FIG. 7 is a cross sectional view taken along lines 7-7 shown in FIG. 3.
A rear view is identical to the front view and is omitted. A left side view is identical to the right side view and is omitted. The broken line showing portions of a spike pin depicts environment and forms no part of the claim.

1 Claim, 7 Drawing Sheets

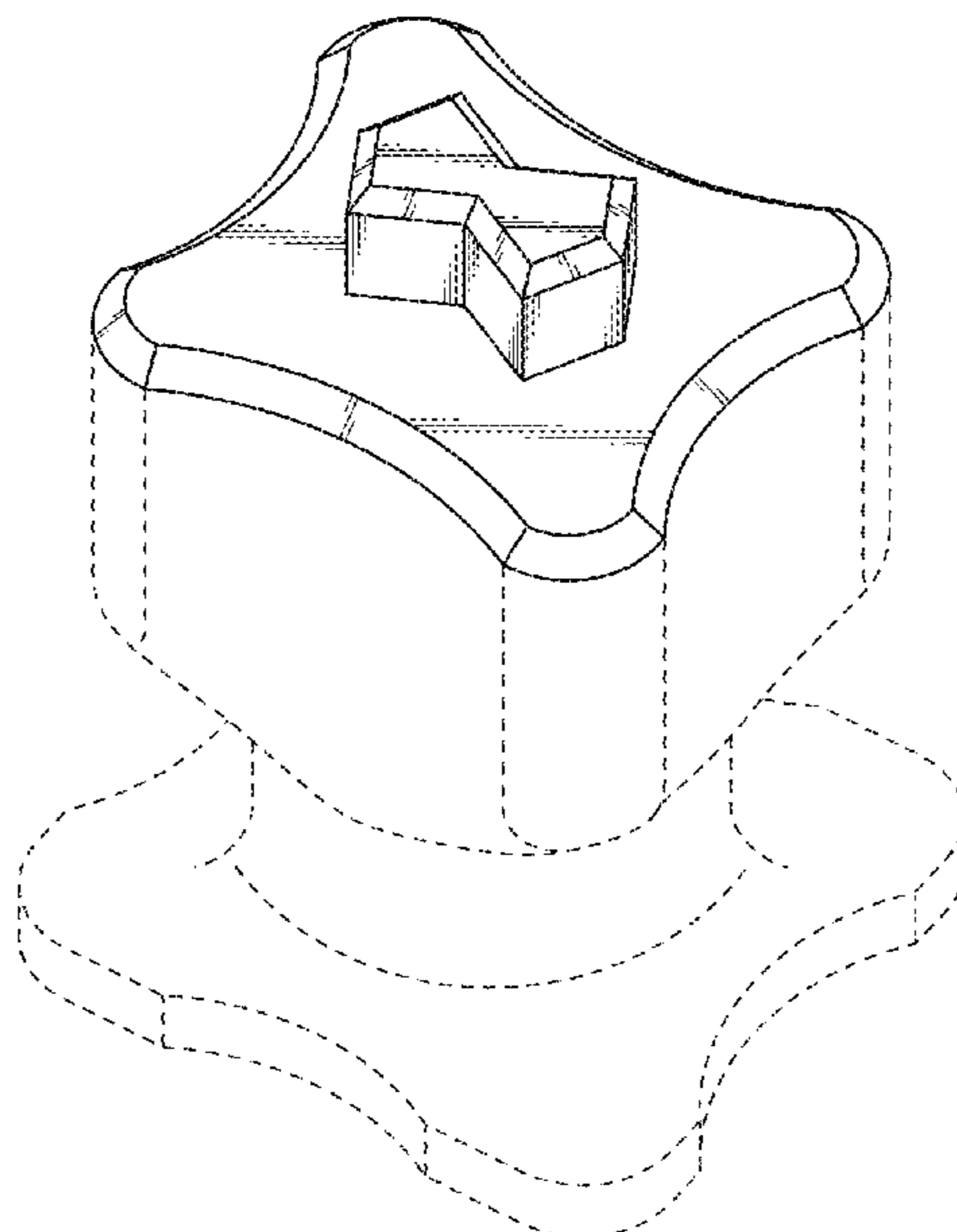

FIG. 1

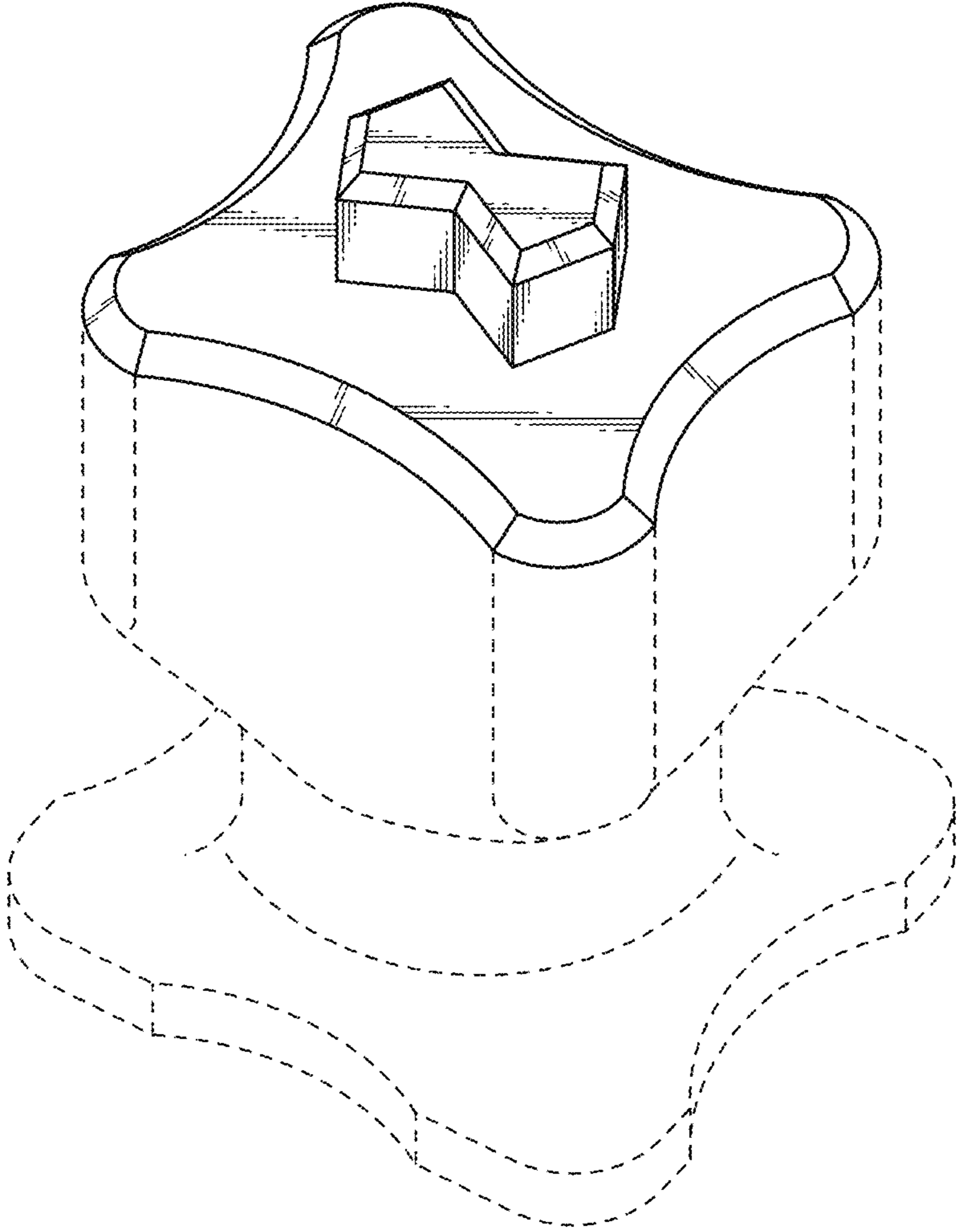

FIG. 2

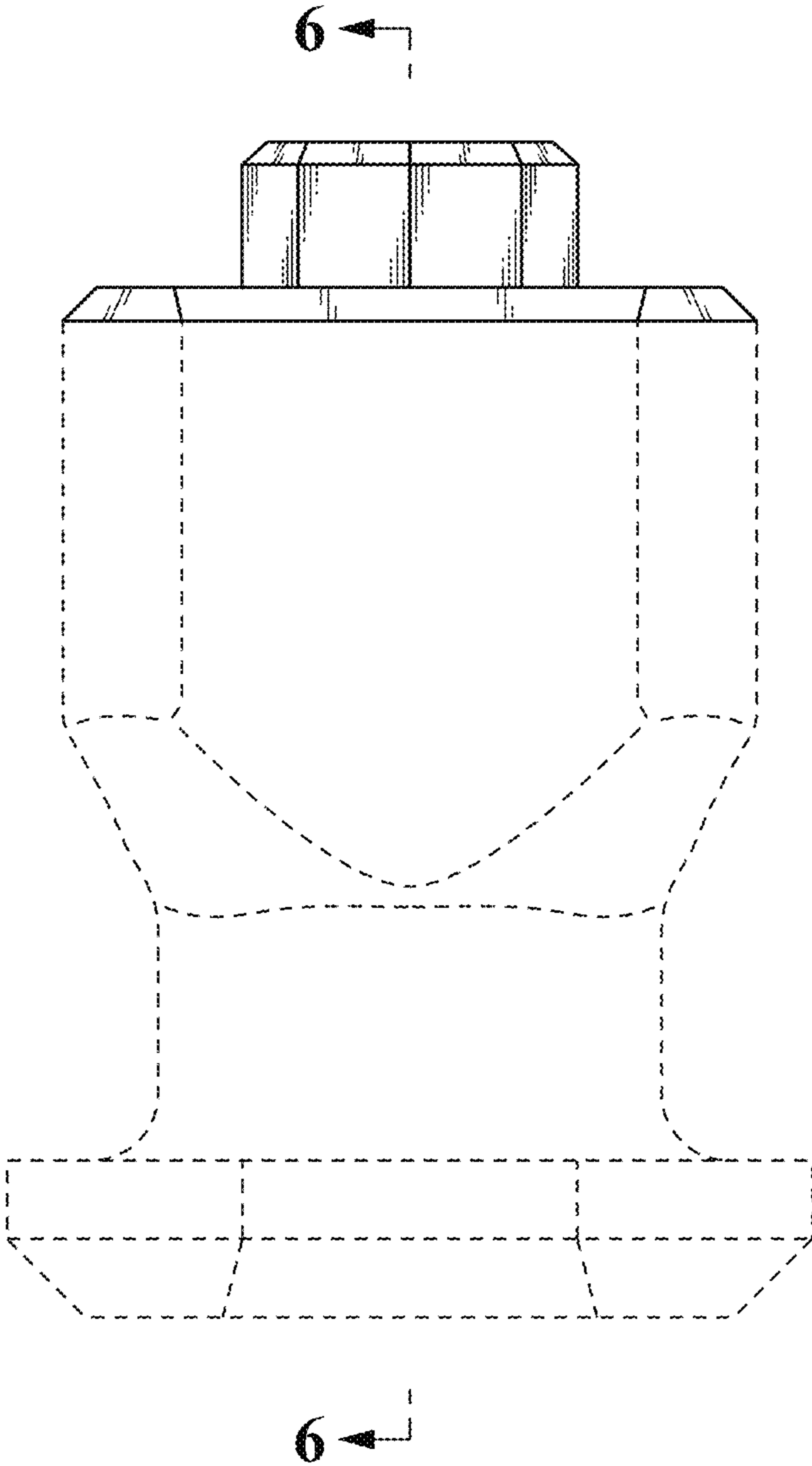

FIG. 3

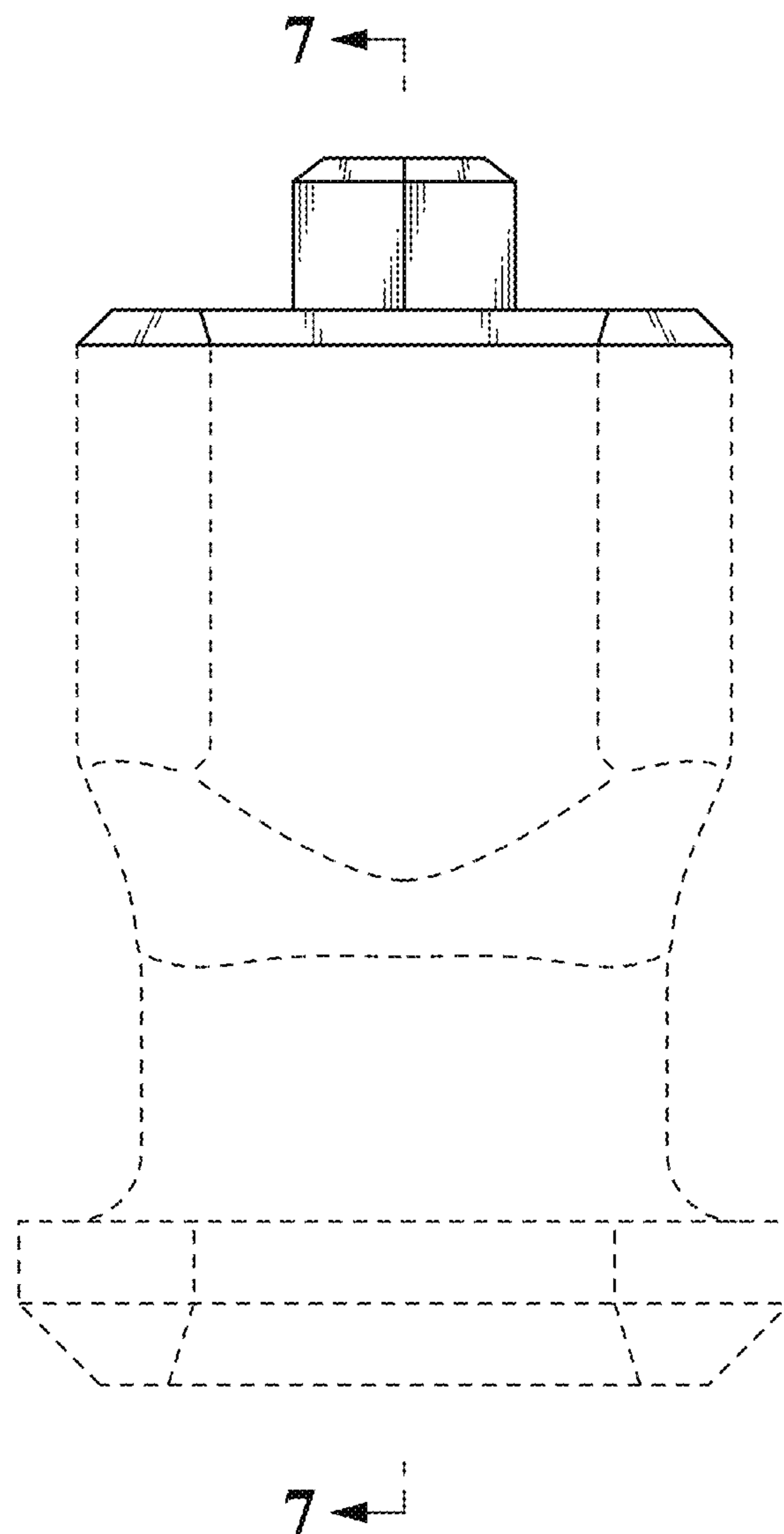

FIG. 4

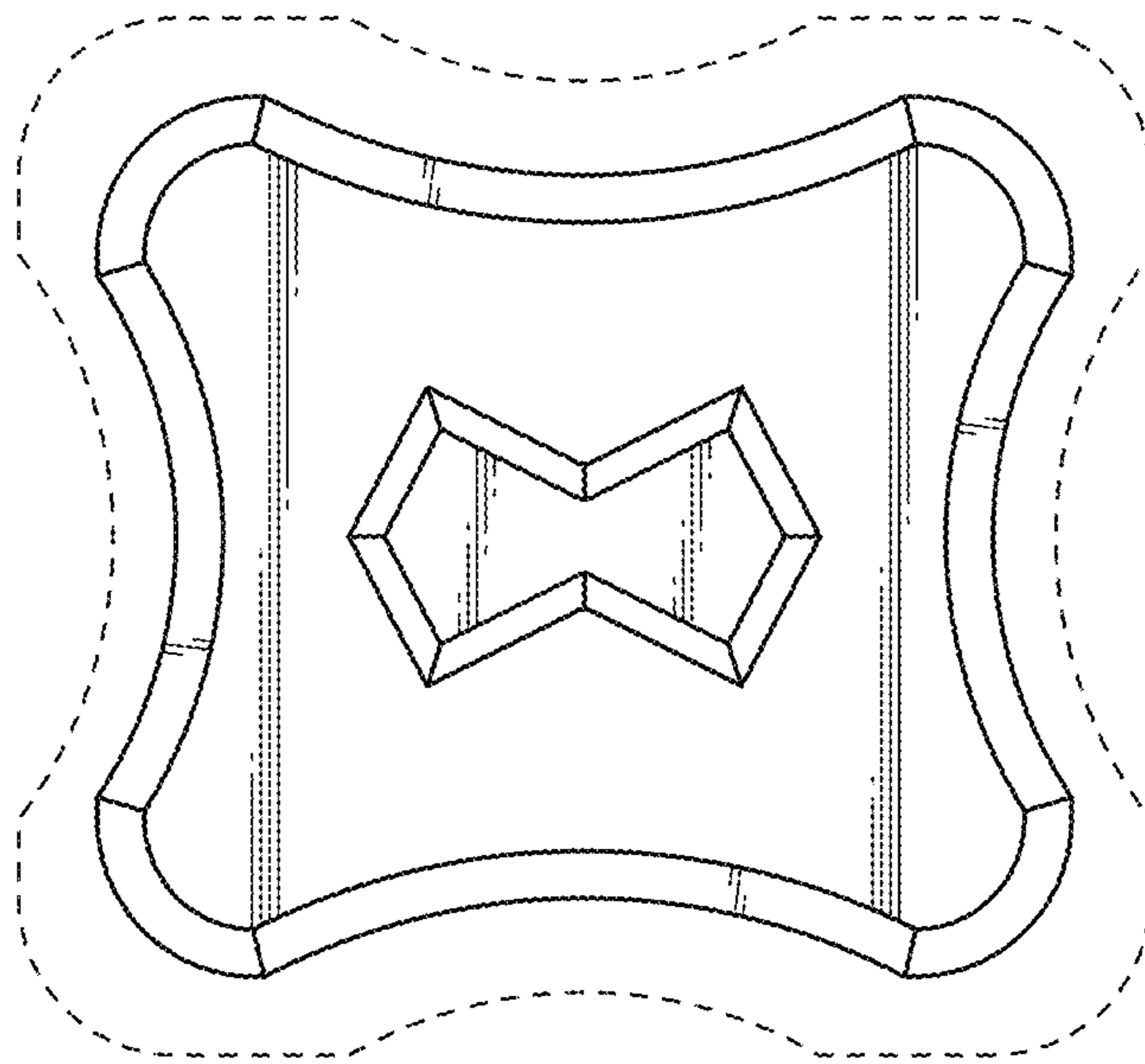

FIG. 5

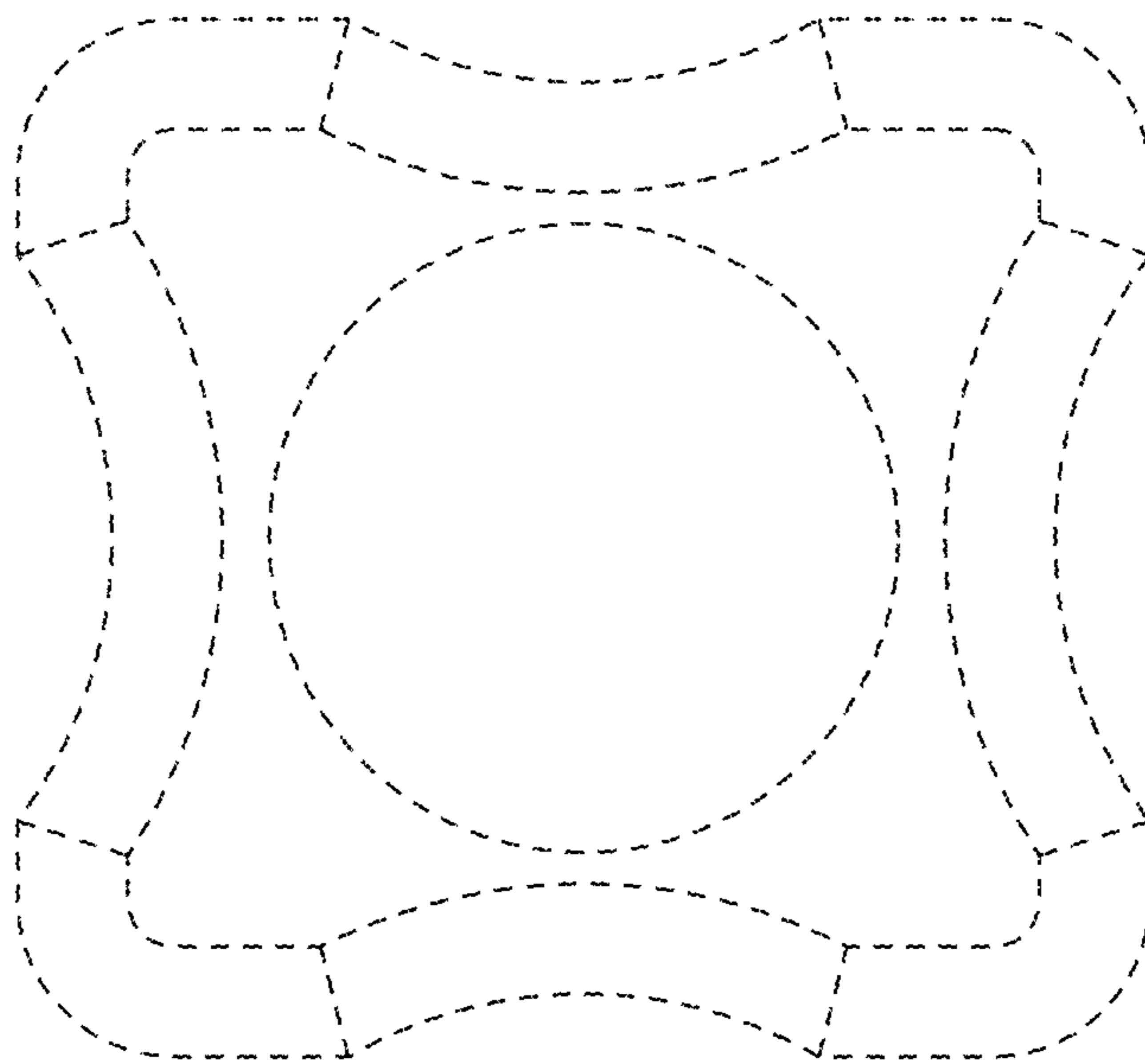

FIG. 6

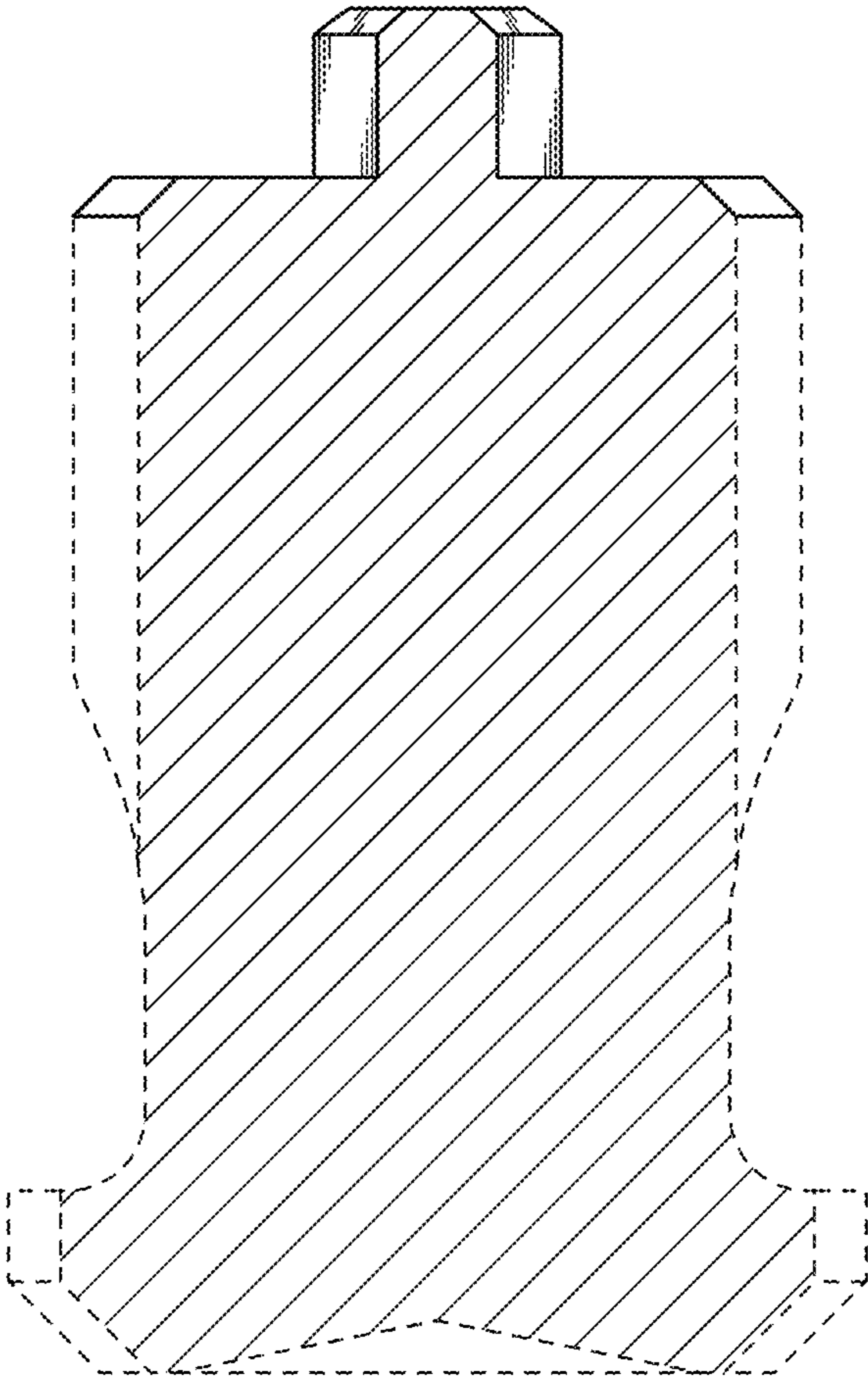

FIG. 7

