



US00D776013S

(12) **United States Design Patent**
Kiska

(10) **Patent No.:** **US D776,013 S**

(45) **Date of Patent:** **** Jan. 10, 2017**

- (54) **MOTORCYCLE**
- (71) Applicant: **KTM Motorrad AG**, Mattighofen (AT)
- (72) Inventor: **Gerald Kiska**, Anif-Salzburg (AT)
- (73) Assignee: **KTM MOTORRAD AG**, Mattighofen (AT)

D401,892 S	*	12/1998	Sugimoto	D12/110
D407,047 S	*	3/1999	Otsubo	D12/110
D447,985 S	*	9/2001	Ino	D12/110
D506,163 S	*	6/2005	Uemoto	D12/110
D588,503 S	*	3/2009	Idei	D12/110
D605,088 S	*	12/2009	Tanaka	D12/110
D723,979 S	*	3/2015	Yu	D12/110
D732,436 S	*	6/2015	Christoph	D12/110
D734,214 S	*	7/2015	Honda	D12/110
D744,906 S	*	12/2015	Song	D12/110

(**) Term: **14 Years**

(21) Appl. No.: **29/525,435**

(22) Filed: **Apr. 29, 2015**

(51) **LOC (10) Cl.** **12-11**

(52) **U.S. Cl.**
USPC **D12/110**

(58) **Field of Classification Search**
 USPC D12/109, 110, 111, 114, 117, 126, 184,
 D12/186; D21/432, 458, 538;
 180/210–217, 219, 220, 225, 229, 908;
 280/103, 124, 152.1–152.3, 288.2, 288.4,
 280/304.3, 770, 827, 828, 847, 848;
 296/77.1, 78.1, 181.1, 187.01, 187.12,
 296/192, 193.01, 193.04, 193.05, 193.09;
 446/440
 CPC B62D 37/00; B62D 57/00; B62K 9/00;
 B62K 11/04; B62K 17/00; B62K 19/48;
 B62K 11/00; B62K 11/02; B62K 11/10;
 B62K 19/00; B62K 2202/00; B62M 7/12;
 F02B 61/02; A63H 17/21; B62J
 17/00; B62J 17/04; B62J 29/00
 See application file for complete search history.

(56) **References Cited**

U.S. PATENT DOCUMENTS

4,809,800 A	*	3/1989	Suzuki	B62K 11/00 180/219
D333,806 S	*	3/1993	Davidson	D12/110
D392,601 S	*	3/1998	Ban	D12/110

OTHER PUBLICATIONS

“2009 KTM Street Bike Models Photos.” Moto USA., Jul. 7, 2008 [online], [retrieved on Jul. 20, 2016]. Retrieved from the Internet <URL: <http://www.motorcycle-usa.com/photo-gallery/2009-ktm-street-bike-models/>>.*

(Continued)

Primary Examiner — Darlington Ly
(74) *Attorney, Agent, or Firm* — Lewis Roca Rothgerber Christie LLP

(57) **CLAIM**

The ornamental design for a motorcycle, as shown and described.

DESCRIPTION

FIG. 1 is a front and right side perspective view of a motorcycle showing my new design;
 FIG. 2 is a front elevation view thereof;
 FIG. 3 is a rear elevation view thereof;
 FIG. 4 is a left side elevation view thereof;
 FIG. 5 is a right side elevation view thereof;
 FIG. 6 is a top plan view thereof;
 FIG. 7 is a bottom plan view thereof;
 FIG. 8 is a rear and right side perspective view thereof; and,
 FIG. 9 is a rear, top, and right side perspective view thereof.
 The broken lines in the drawings illustrate portions of the motorcycle that form no part of the claimed design.

1 Claim, 9 Drawing Sheets

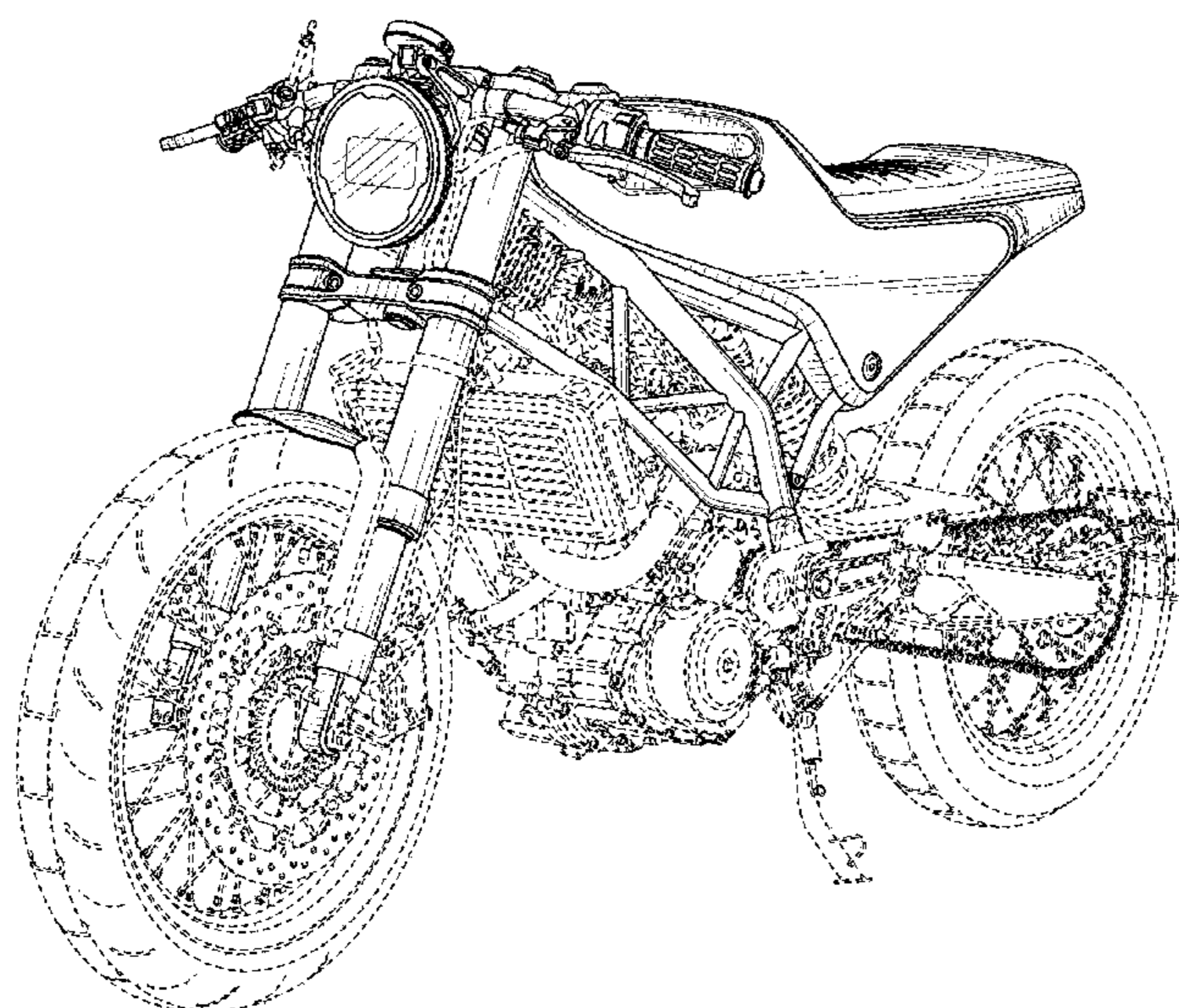

(56)

References Cited

OTHER PUBLICATIONS

Duke, Kevin. "2013 KTM 690 Duke Review—Video." Motorcycle., Jun. 5, 2013 [online], [retrieved on Jul. 20, 2016]. Retrieved from the Internet <URL: <http://www.motorcycle.com/manufacture/ktm/2013-ktm-690-duke-review-video-91645.html>>.*

Wilson, Bryan. "2015 Zero Motorcycle Line First Look." Moto USA., Sep. 30, 2014 [online], [retrieved on Jul. 20, 2016]. Retrieved from the Internet <URL: <http://www.motorcycle-usa.com/2014/09/article/2015-zero-motorcycle-line-first-look/>>.*

Duke, Kevin. "2015 Ducati Scrambler Unveiled! + Video." Motorcycle., Sep. 30, 2014 [online], [retrieved on Jul. 20, 2016]. Retrieved from the Internet <URL: <http://www.motorcycle.com/manufacture/ducati/2015-ducati-scrambler-unveiled-video.html>>.*

U.S. Appl. No. 29/525,436, Gerald Kiska, Motorcycle, filed Apr. 29, 2015.

U.S. Appl. No. 29/525,437, Gerald Kiska, Engine Cover for Motorcycles, filed Apr. 29, 2015.

* cited by examiner

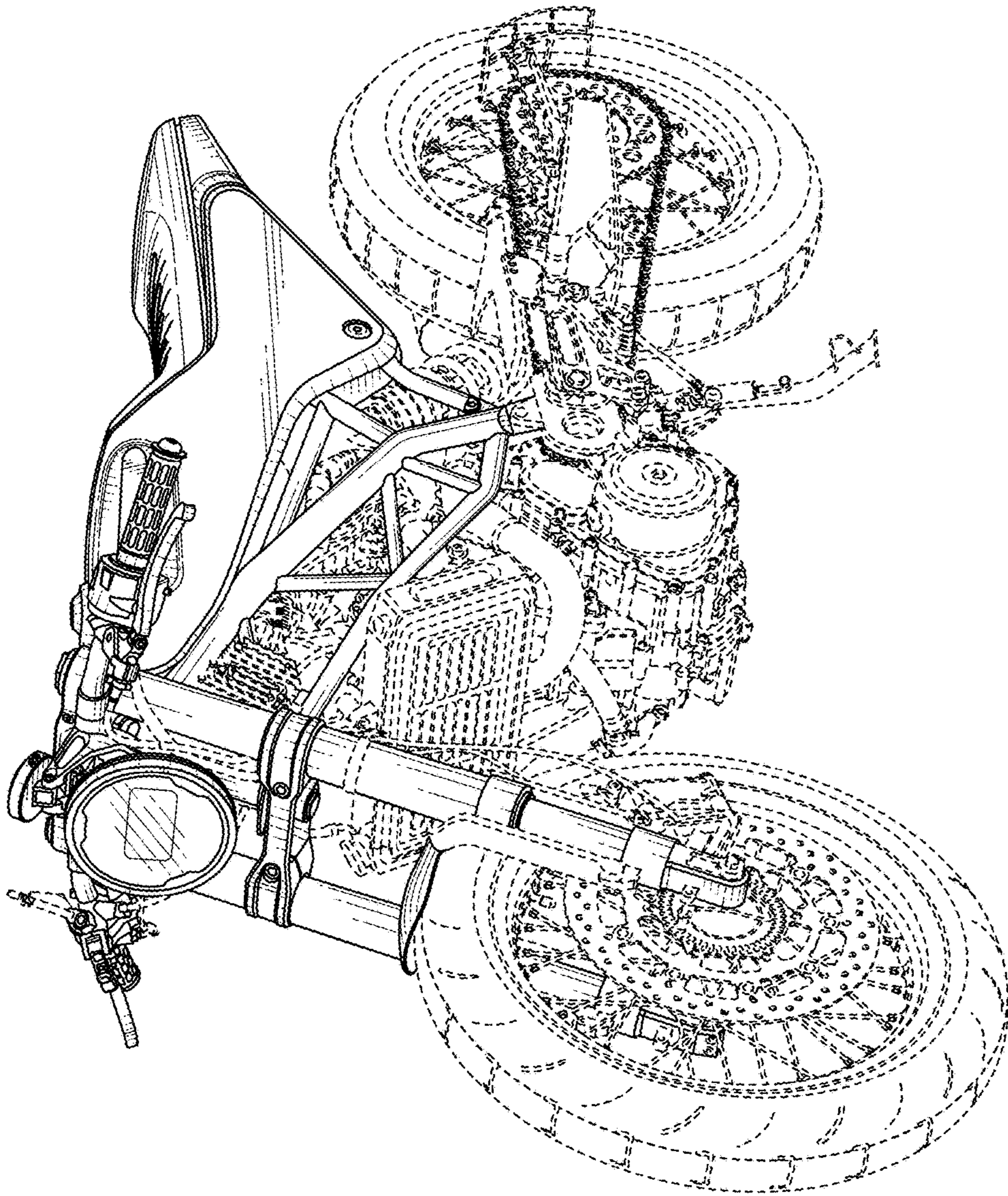

FIG. 1

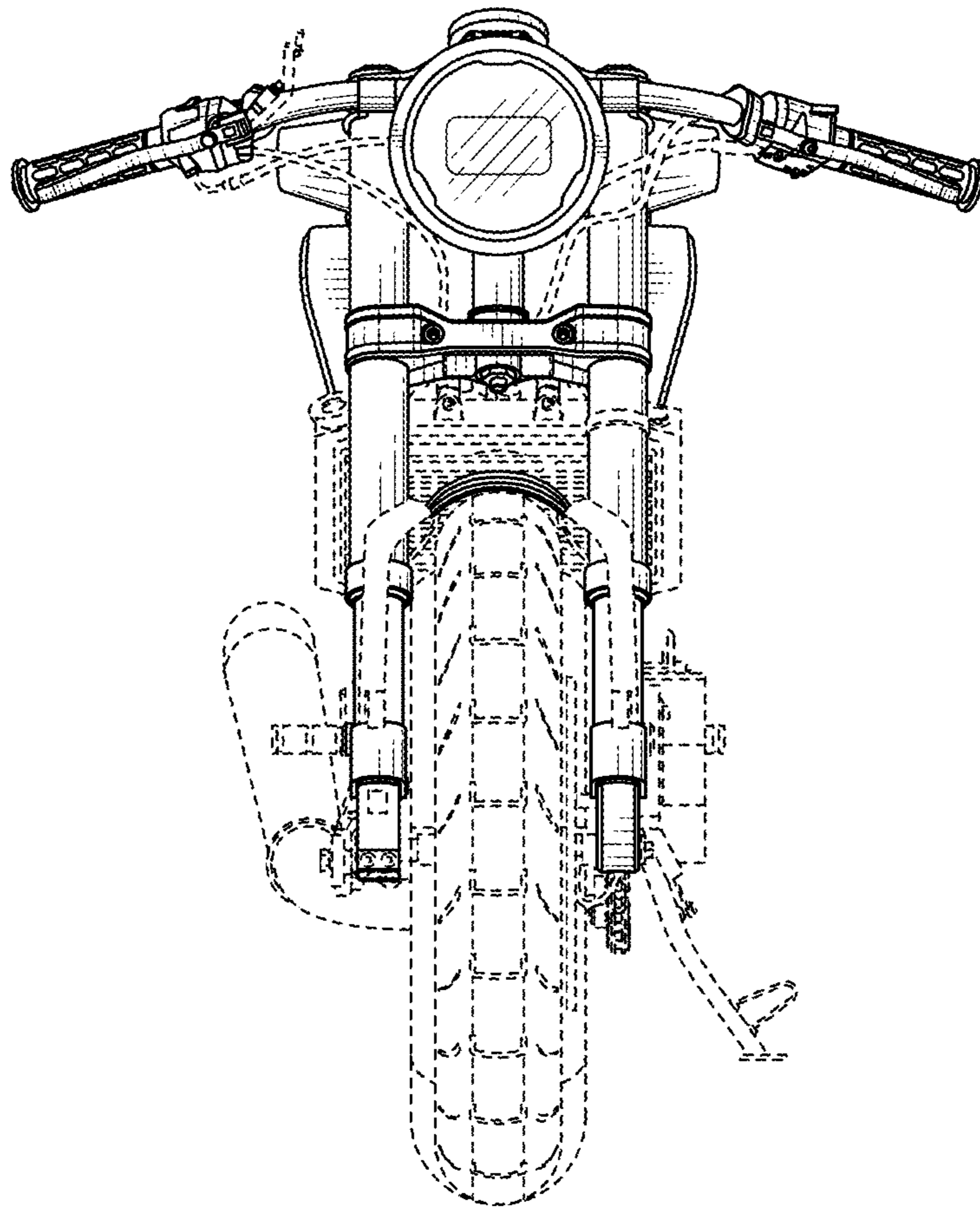

FIG. 2

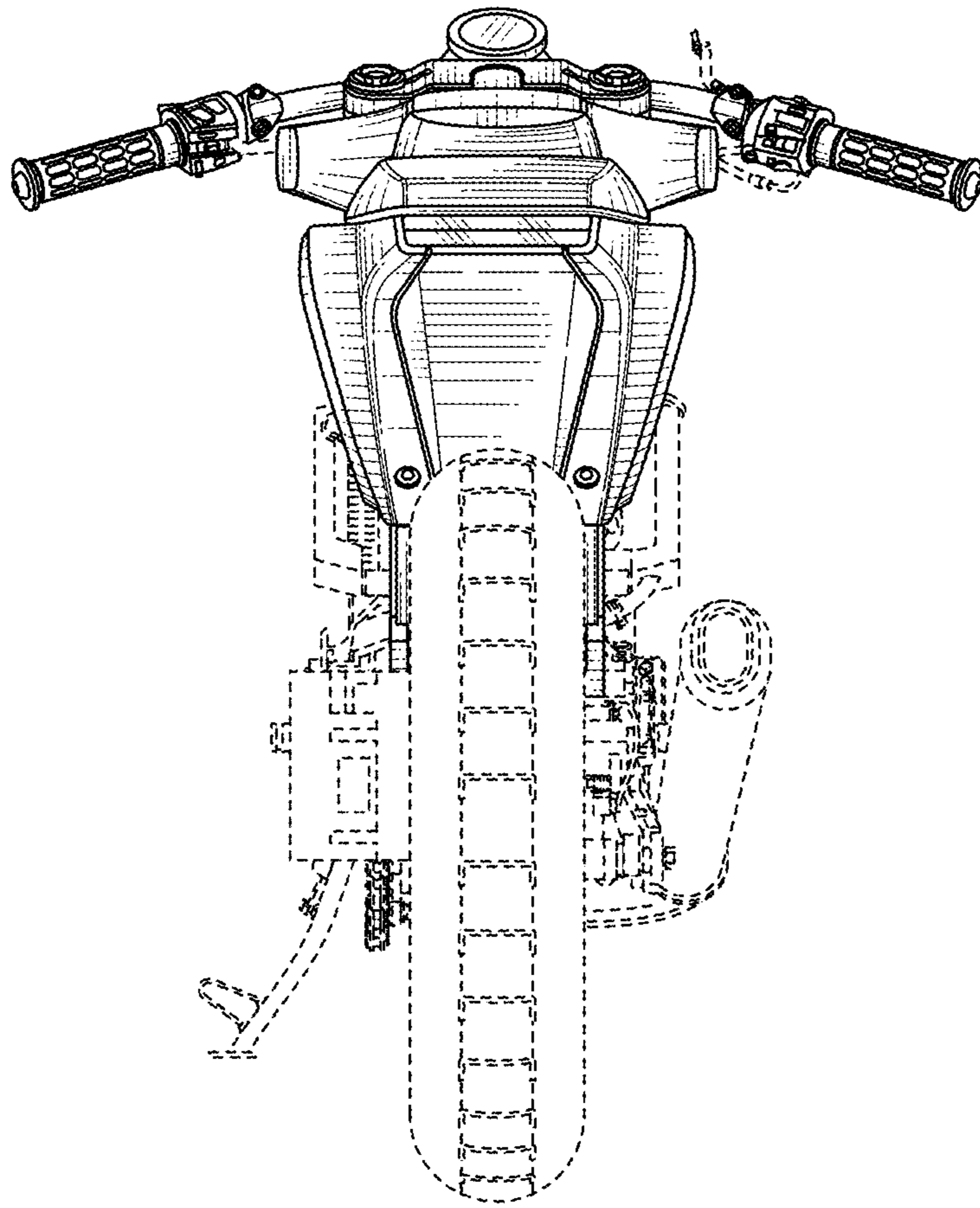

FIG. 3

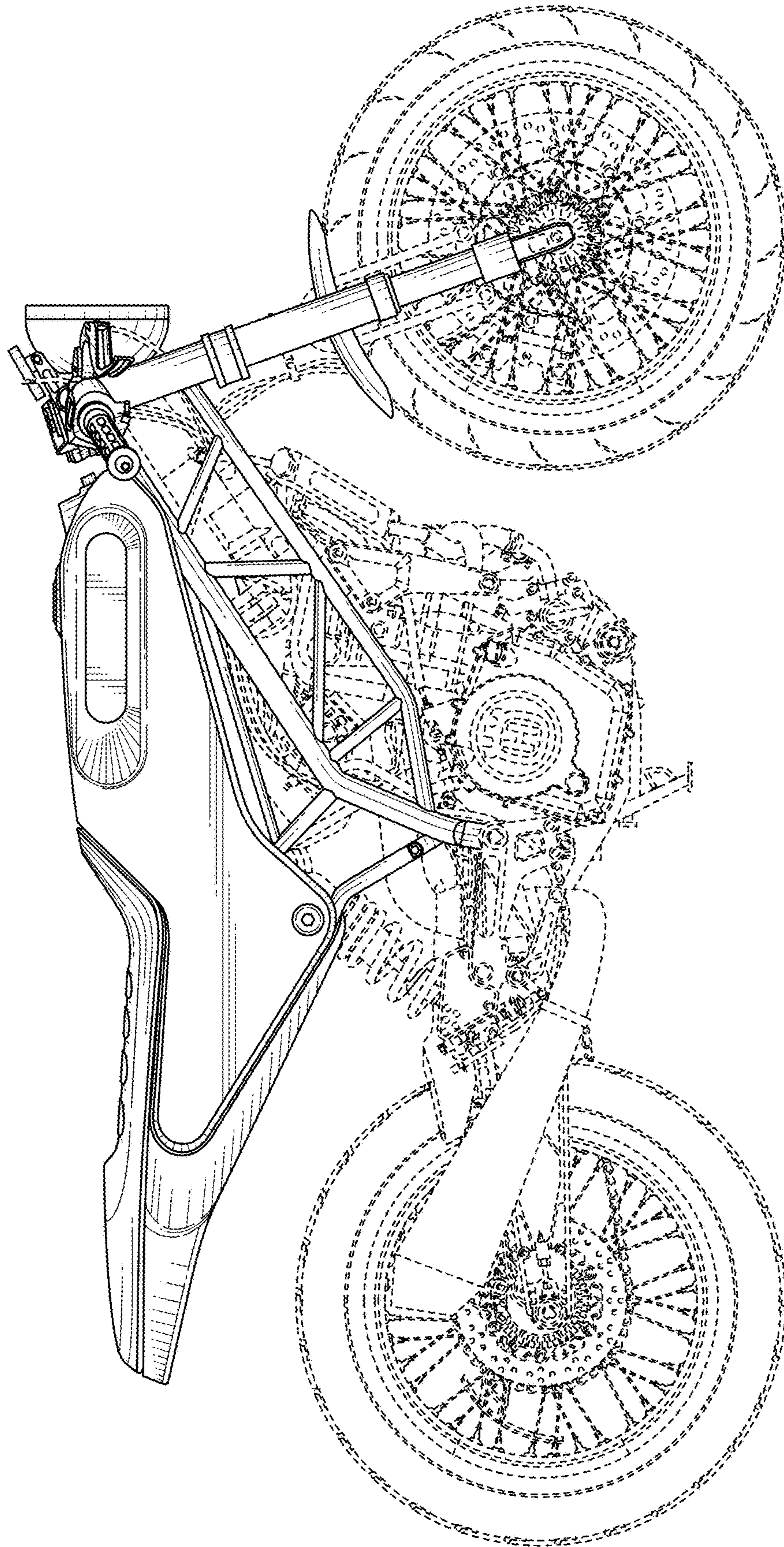

FIG. 4

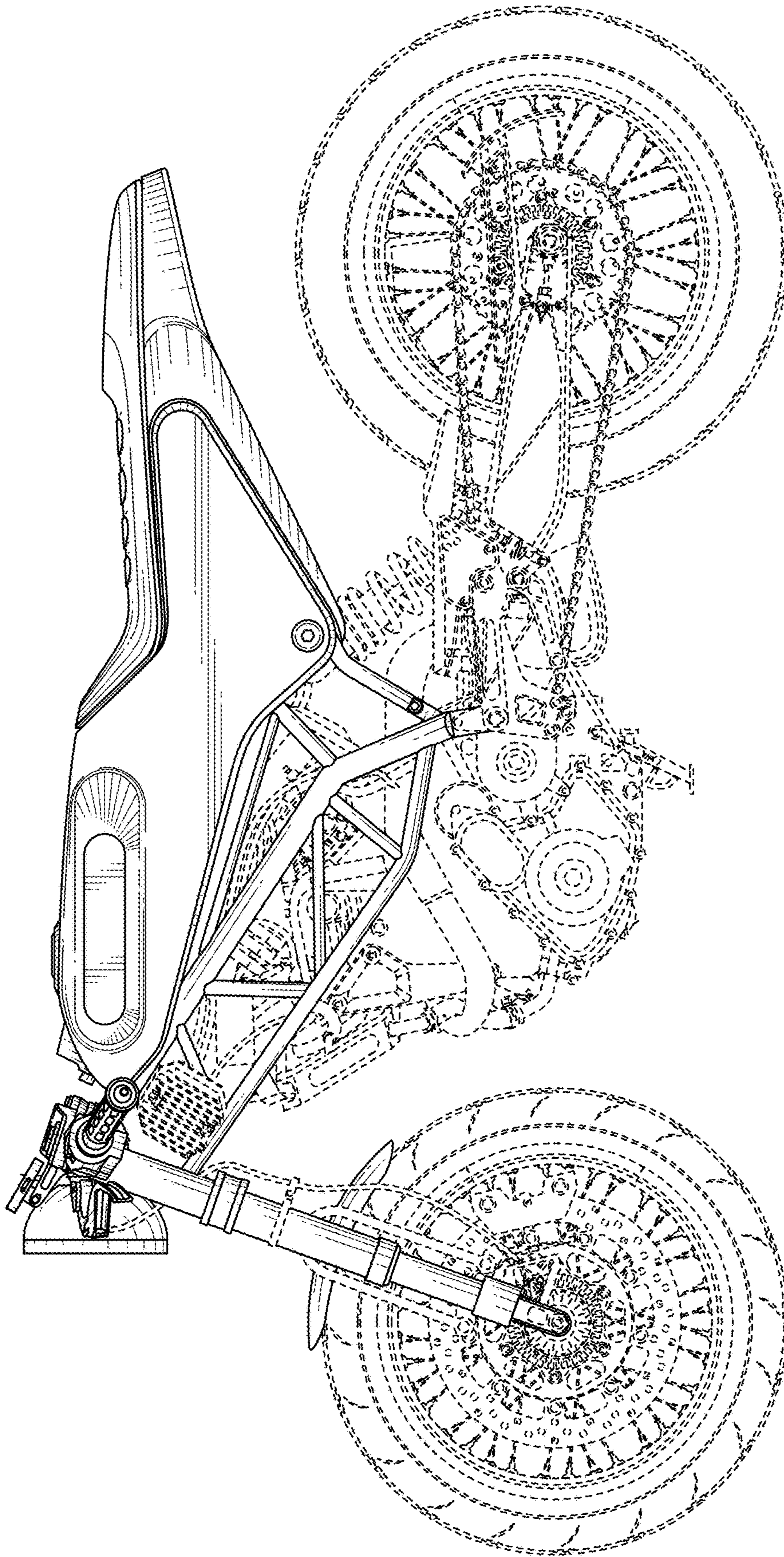

FIG. 5

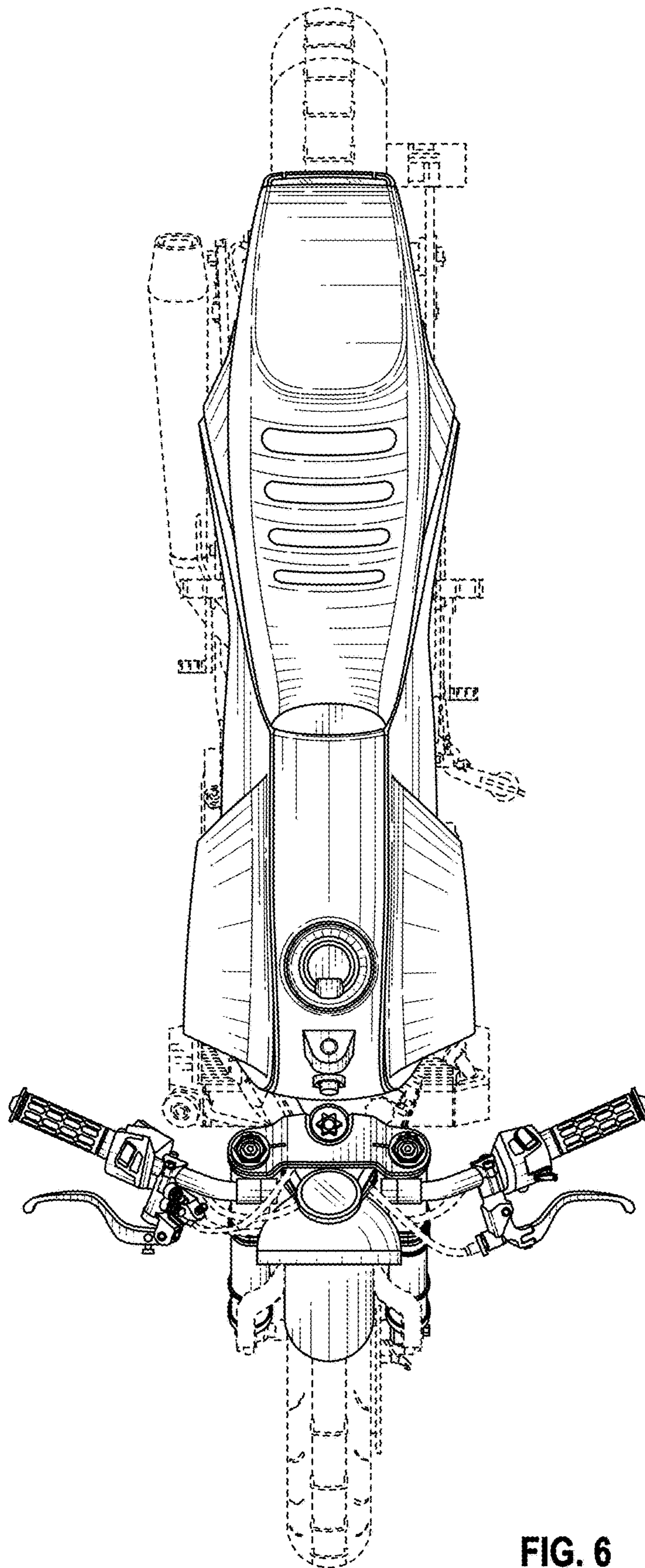

FIG. 6

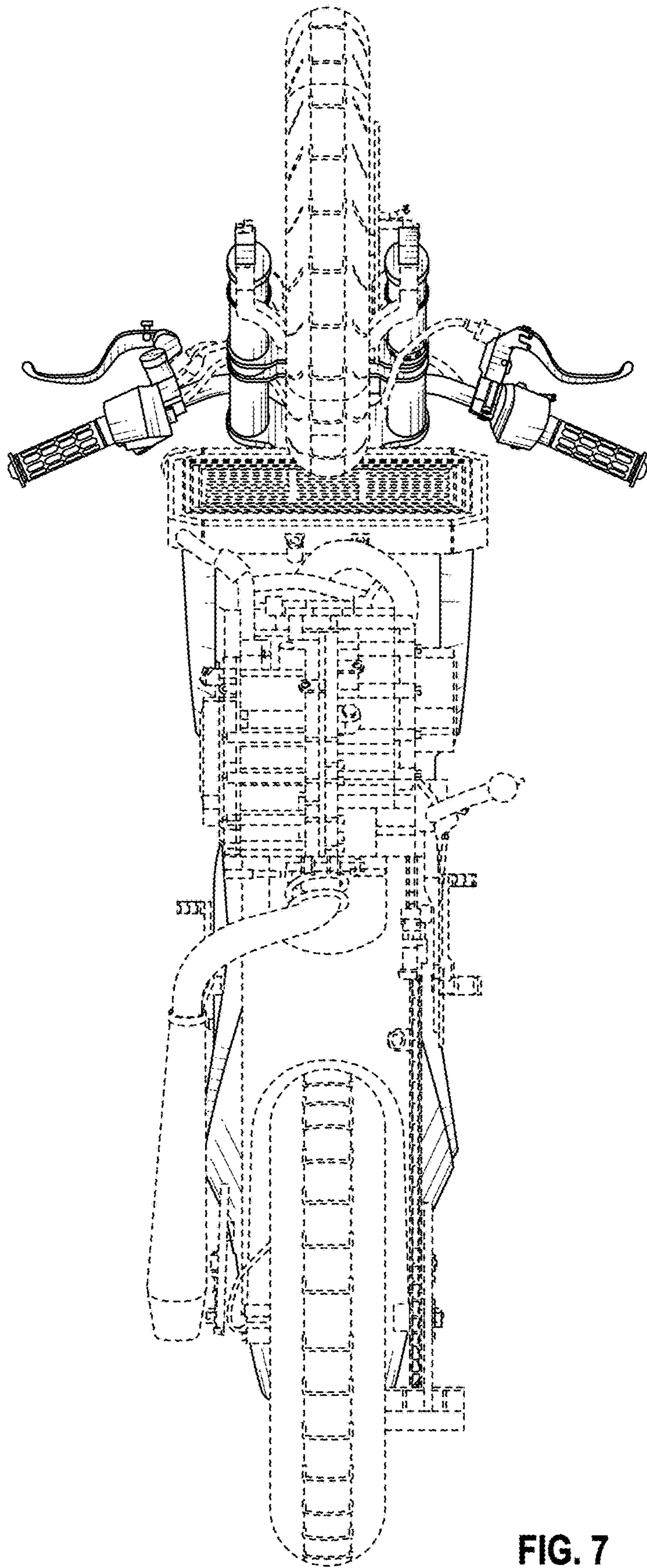

FIG. 7

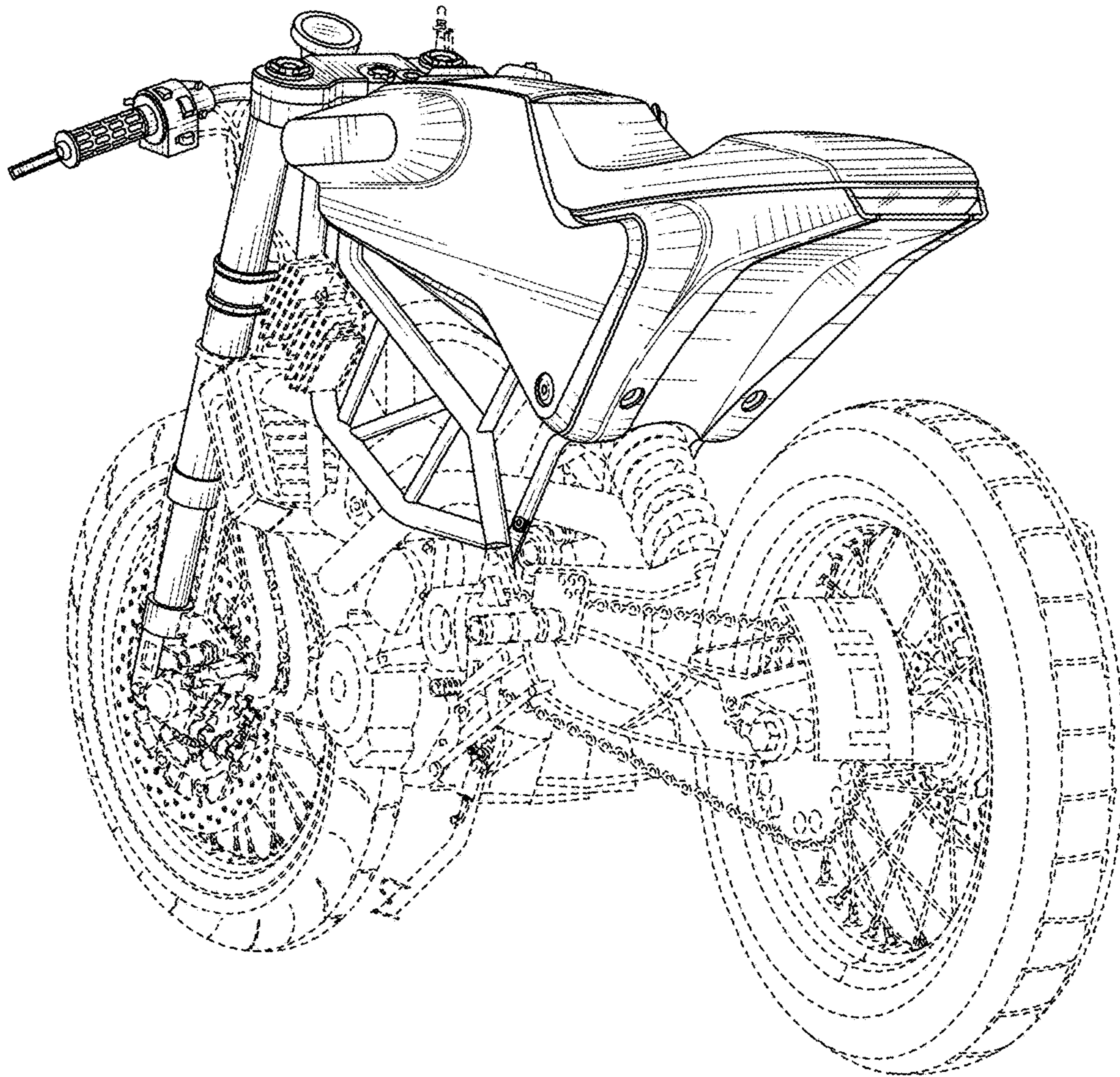

FIG. 8

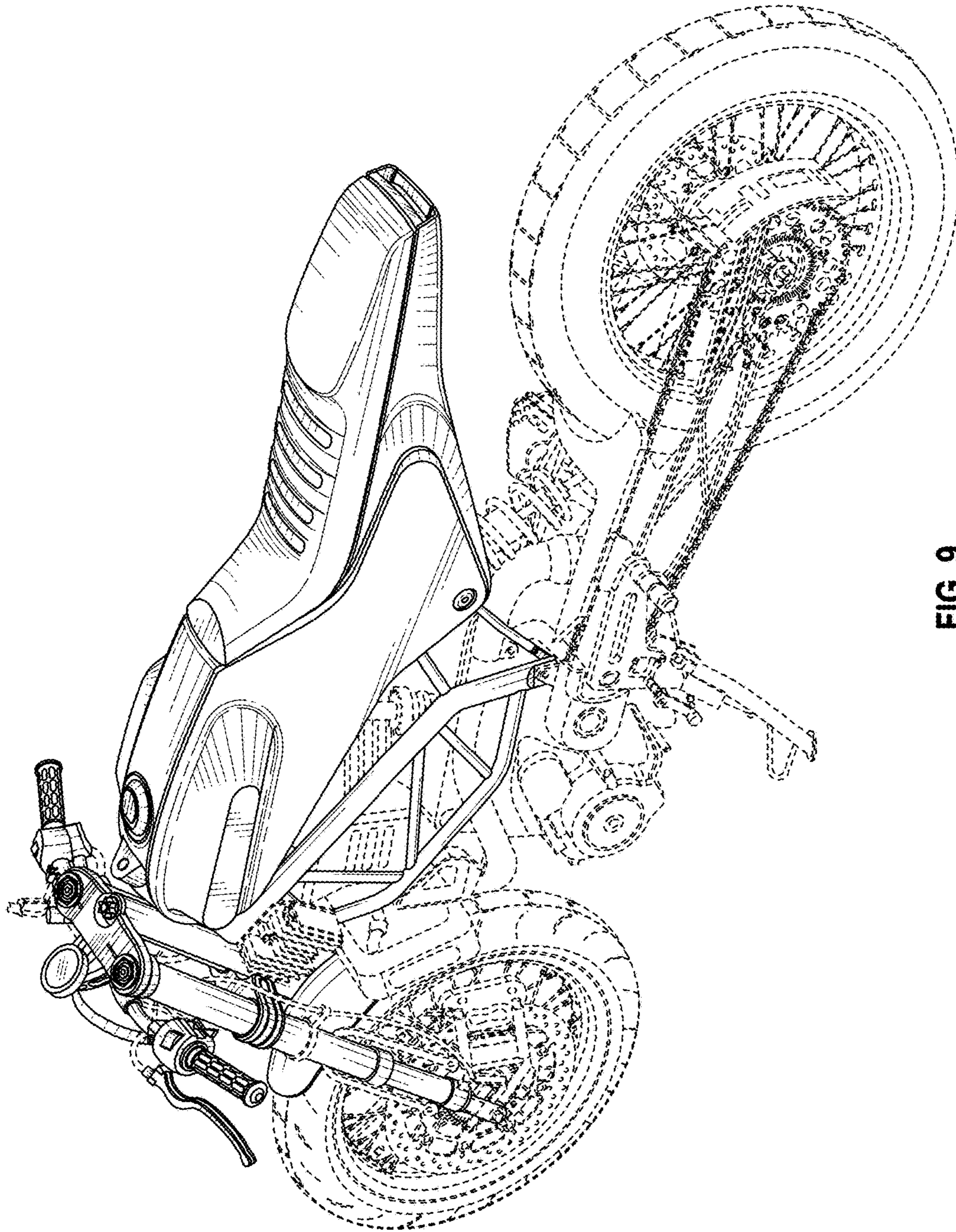

FIG. 9