



US00D775730S

(12) **United States Design Patent** (10) **Patent No.:** **US D775,730 S**
Suwito et al. (45) **Date of Patent:** **** Jan. 3, 2017**

(54) **INSERTION TOOL FOR AN IMPLANTABLE MONITORING DEVICE**

D405,883 S * 2/1999 Emerson D24/133
D708,324 S * 7/2014 Schwarz D24/133
D708,741 S * 7/2014 Harrison D24/133
D714,936 S * 10/2014 Weber D24/133

(71) Applicant: **BIOTRONIK SE & Co. KG**, Berlin (DE)

* cited by examiner

(72) Inventors: **Wantjinarjo Suwito**, West Linn, OR (US); **Hannes Kraetschmer**, West Linn, OR (US); **Jeffrey A. von Arx**, Lake Oswego, OR (US); **Dirk Muessig**, West Linn, OR (US); **Larry Stotts**, Tigard, OR (US)

Primary Examiner — Robert M Spear
Assistant Examiner — Eliza Bennett-Hattan
(74) *Attorney, Agent, or Firm* — Buchanan Ingersoll & Rooney PC

(73) Assignee: **BIOTRONIK SE & Co. KG**, Berlin (DE)

(57) **CLAIM**

(**) Term: **15 Years**

The ornamental design for an insertion tool for an implantable monitoring device, as shown and described.

(21) Appl. No.: **29/526,738**

(22) Filed: **May 13, 2015**

DESCRIPTION

(51) **LOC (10) Cl.** **24-02**

(52) **U.S. Cl.**
USPC **D24/147**

(58) **Field of Classification Search**
USPC D24/108, 112, 117, 118, 133, 135, 137, D24/138, 222, 141, 111, 113, 127, 143, D24/148, 179, 216, 152, 153, 154, 176; D8/4, 29.1, 29.2, 30, 31, 39; D17/10, D17/13; D23/266
CPC A61B 17/1604; A61B 17/3468; A61B 2017/0409; A61B 17/15; A61C 8/0089; A61N 1/05; A61M 25/0662; A61M 27/002; A61M 2210/0681; A61M 25/0105; A61M 31/00; A61M 2025/0004; A61M 2025/0006

See application file for complete search history.

FIG. 1 is a bottom, front, proximal side (i.e. perspective) view of the insertion tool for an implantable monitoring device with a distal end on the left side and a proximal end on the right side;
FIG. 2 is a rear side view of the insertion tool for an implantable monitoring device with a distal end on the right side and a proximal end on the left side;
FIG. 3 is a front side view of the insertion tool for an implantable monitoring device with a distal end on the left side and a proximal end on the right side;
FIG. 4 is a distal front view of the insertion tool for an implantable monitoring device;
FIG. 5 is a proximal rear view of the insertion tool for an implantable monitoring device;
FIG. 6 is a top view of the insertion tool for an implantable monitoring device; and,
FIG. 7 is a bottom view of the insertion tool for an implantable monitoring device.

The broken lines in the drawing depict environmental subject matter only and form no part of the claimed design.

(56) **References Cited**

U.S. PATENT DOCUMENTS

D389,912 S * 1/1998 Emerson D24/133
D398,995 S * 9/1998 Muller D24/133

1 Claim, 7 Drawing Sheets

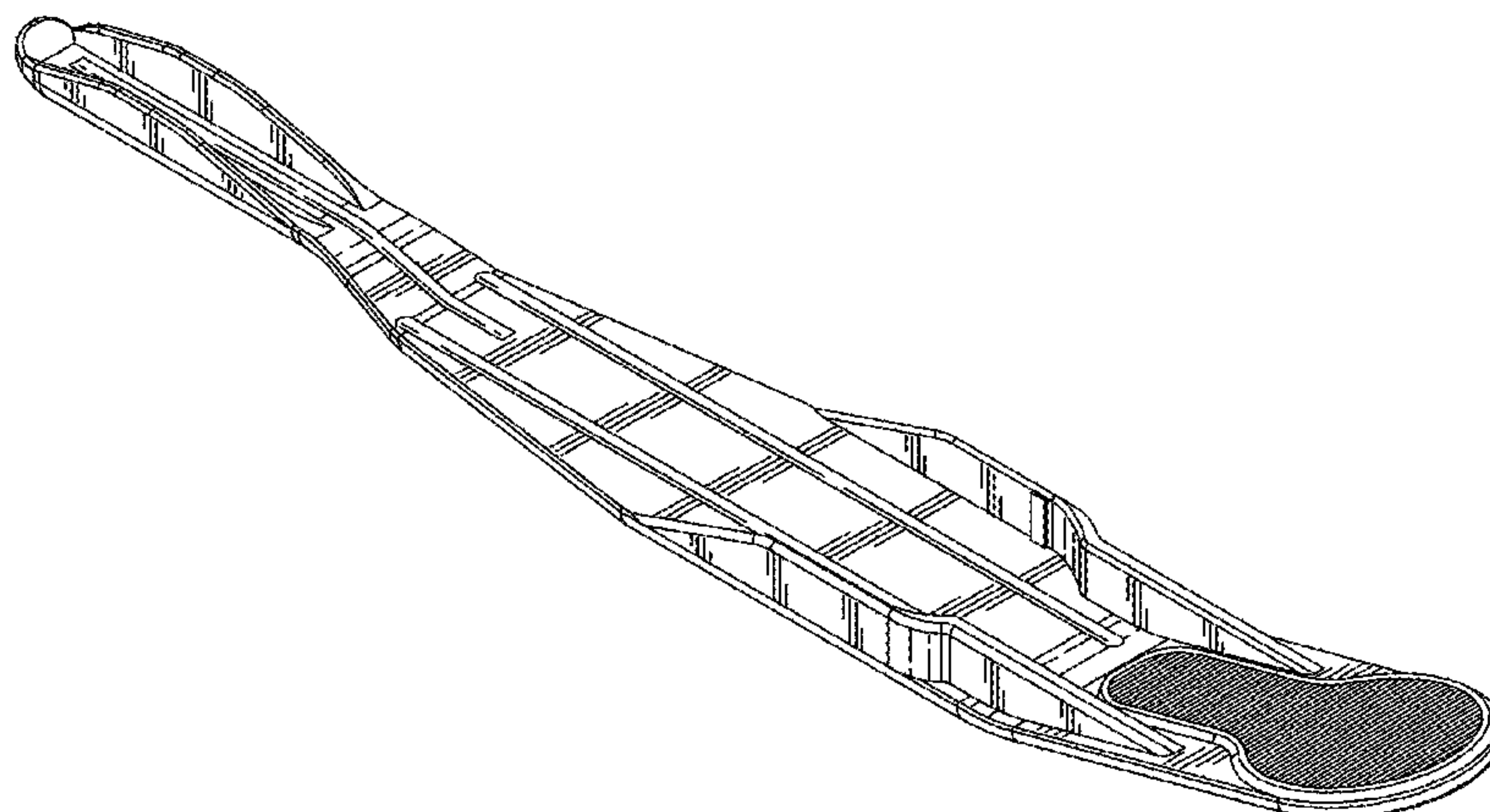

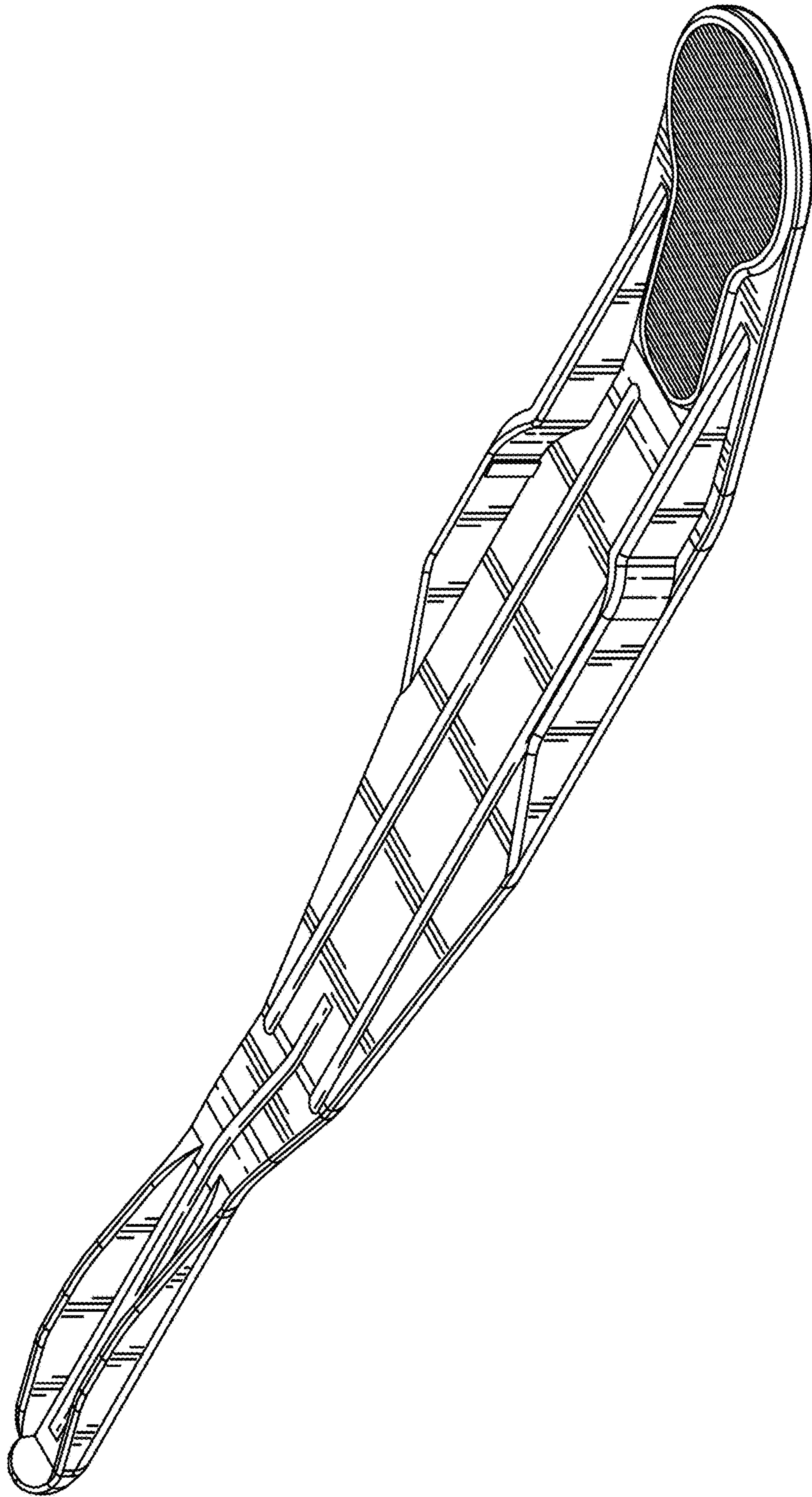

Fig. 1



Fig. 2

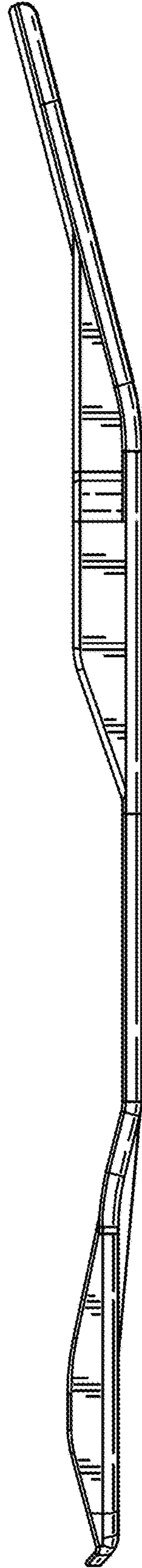

Fig. 3

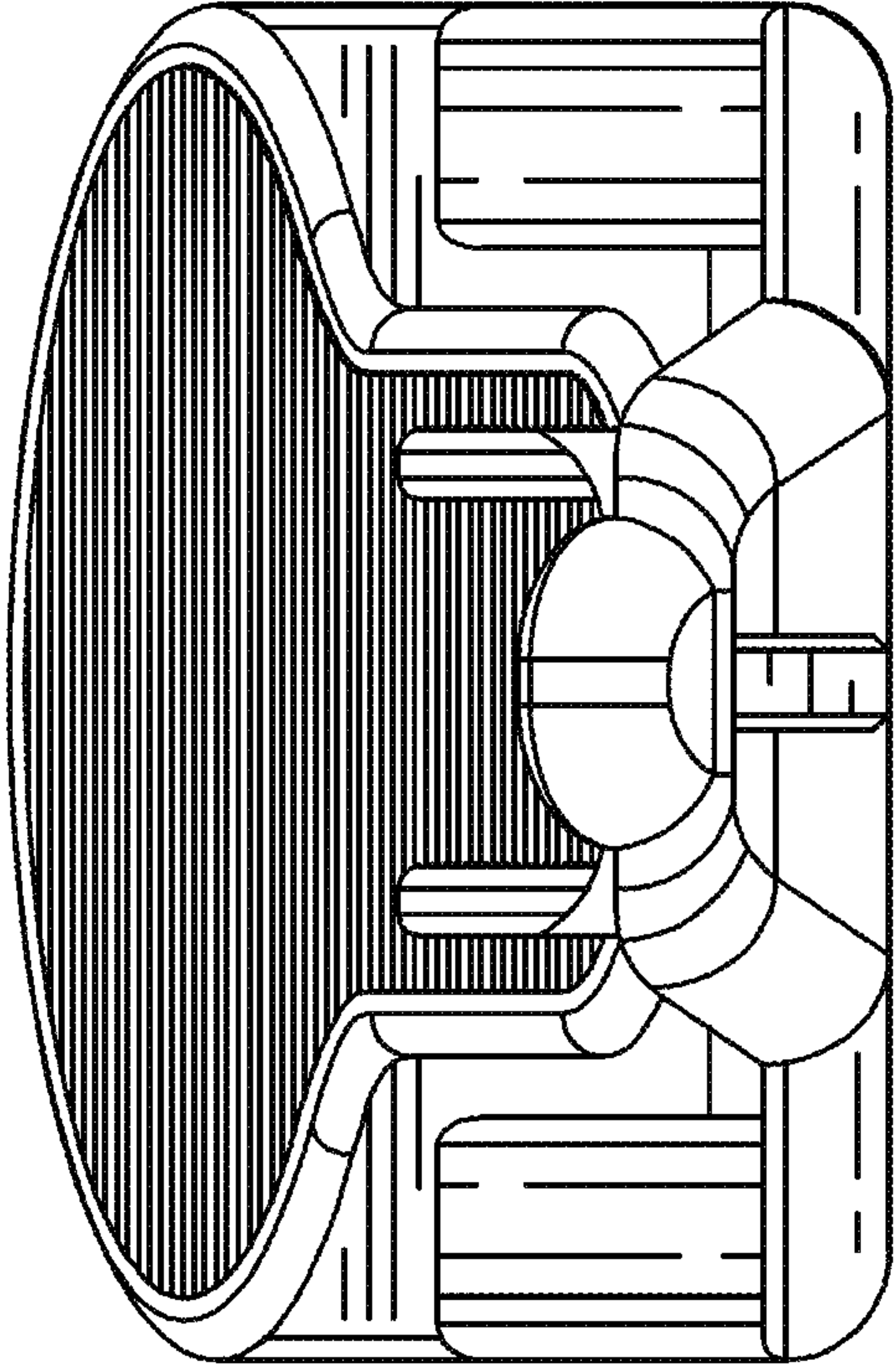

Fig. 4

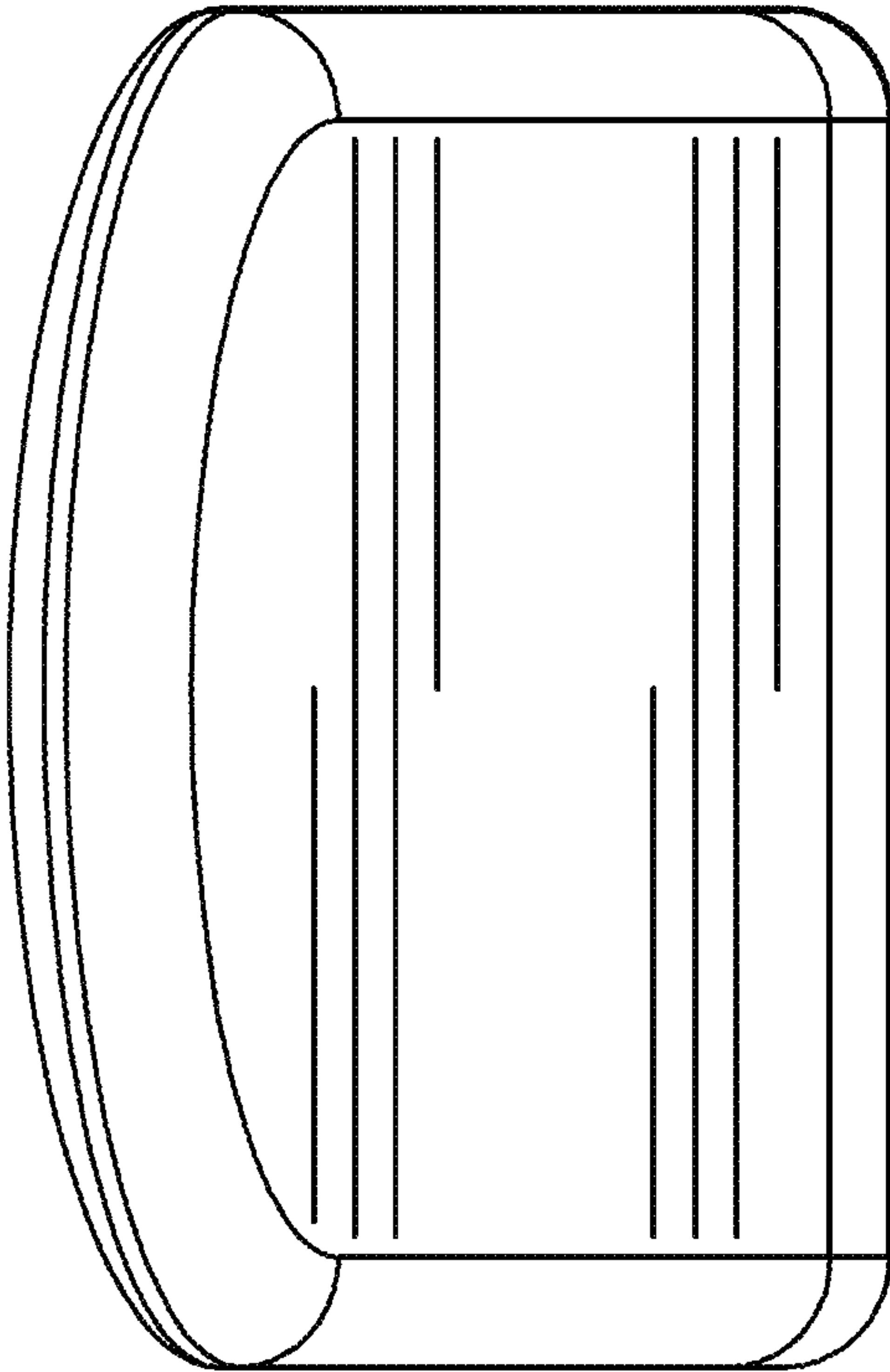

Fig. 5

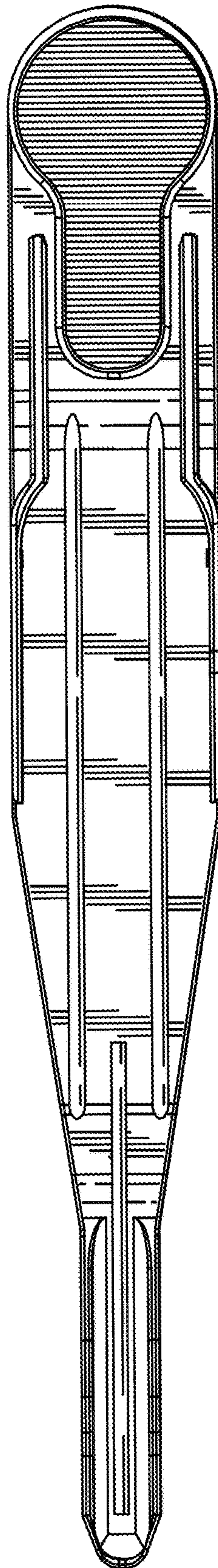

Fig. 6

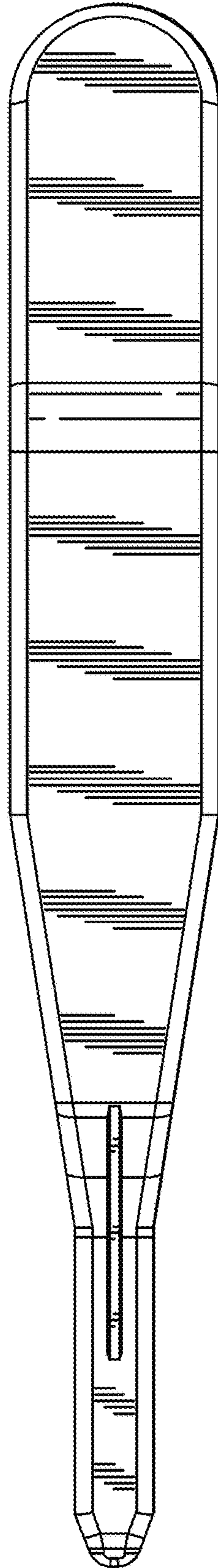

Fig. 7