



US00D775548S

(12) **United States Design Patent**
Beaupré et al.

(10) **Patent No.:** **US D775,548 S**
(45) **Date of Patent:** **** Jan. 3, 2017**

- (54) **BUS**
- (71) Applicant: **CORPORATION MICRO BIRD INC.**, Drummondville (CA)
- (72) Inventors: **Hugues Beaupré**, Drummondville (CA); **Pascal Chabot**, Drummondville (CA)
- (73) Assignee: **CORPORATION MICRO BIRD INC.**, Drummondville (CA)

D551,377 S *	9/2007	Nunes	D26/73
2005/0189802 A1 *	9/2005	Mattes	B60N 2/242
				297/216.13
2007/0101668 A1 *	5/2007	Snider	B60J 1/17
				52/204.51
2009/0189433 A1 *	7/2009	Wilson	B60N 2/242
				297/440.14
2010/0320826 A1 *	12/2010	Wilson	B60N 2/682
				297/452.18
2012/0177336 A1 *	7/2012	Bhan	H04N 5/77
				386/224
2012/0268599 A1 *	10/2012	Schmidt	B60R 1/00
				348/148

(**) Term: **14 Years**

(21) Appl. No.: **29/508,690**

(22) Filed: **Nov. 10, 2014**

(51) **LOC (10) Cl.** **12-08**

(52) **U.S. Cl.**
USPC **D12/84**

(58) **Field of Classification Search**
USPC D12/82, 84, 86, 92, 100; 296/25, 178, 296/203; 280/6.152; 29/897.2
CPC B62D 23/00; B62D 25/00; B62D 31/02; B62D 31/04; B62D 53/062; B62D 65/00; B60G 2202/152; B60G 2300/14; B60P 3/007; B21D 53/88

See application file for complete search history.

(56) **References Cited**

U.S. PATENT DOCUMENTS

D237,699 S *	11/1975	Brennan	D12/84
D272,524 S *	2/1984	Legueu	D12/84
D287,112 S *	12/1986	Legueu	D12/84
D309,643 S *	7/1990	Picozza	D21/552
D314,733 S *	2/1991	Richter, Jr.	D12/84
D329,830 S *	9/1992	Girardin	D12/84
D364,893 S *	12/1995	Willard	D12/84
D409,951 S *	5/1999	Grech	D12/84
D466,442 S *	12/2002	Cornell	D12/84

OTHER PUBLICATIONS

Collins Bus Corporation, Products: Model SL400, <http://www.collinsbuscorp.com/products.php?id=1>.
Collins Bus Corporation, Products: Model SH400, <http://www.collinsbuscorp.com/products.php?id=2>.

(Continued)

Primary Examiner — Darlington Ly

(74) *Attorney, Agent, or Firm* — Gwendoline Bruneau

(57) **CLAIM**

The ornamental design for a bus, as shown and described.

DESCRIPTION

FIG. 1 is a perspective view of a bus according to our new design;

FIG. 2 is a front elevational view thereof;

FIG. 3 is a left side elevational view thereof;

FIG. 4 is a right side elevational view thereof;

FIG. 5 is a rear elevational view thereof; and,

FIG. 6 is a top plan view thereof.

The broken lines in the drawings illustrate portions of the bus that form no part of the claimed design.

1 Claim, 6 Drawing Sheets

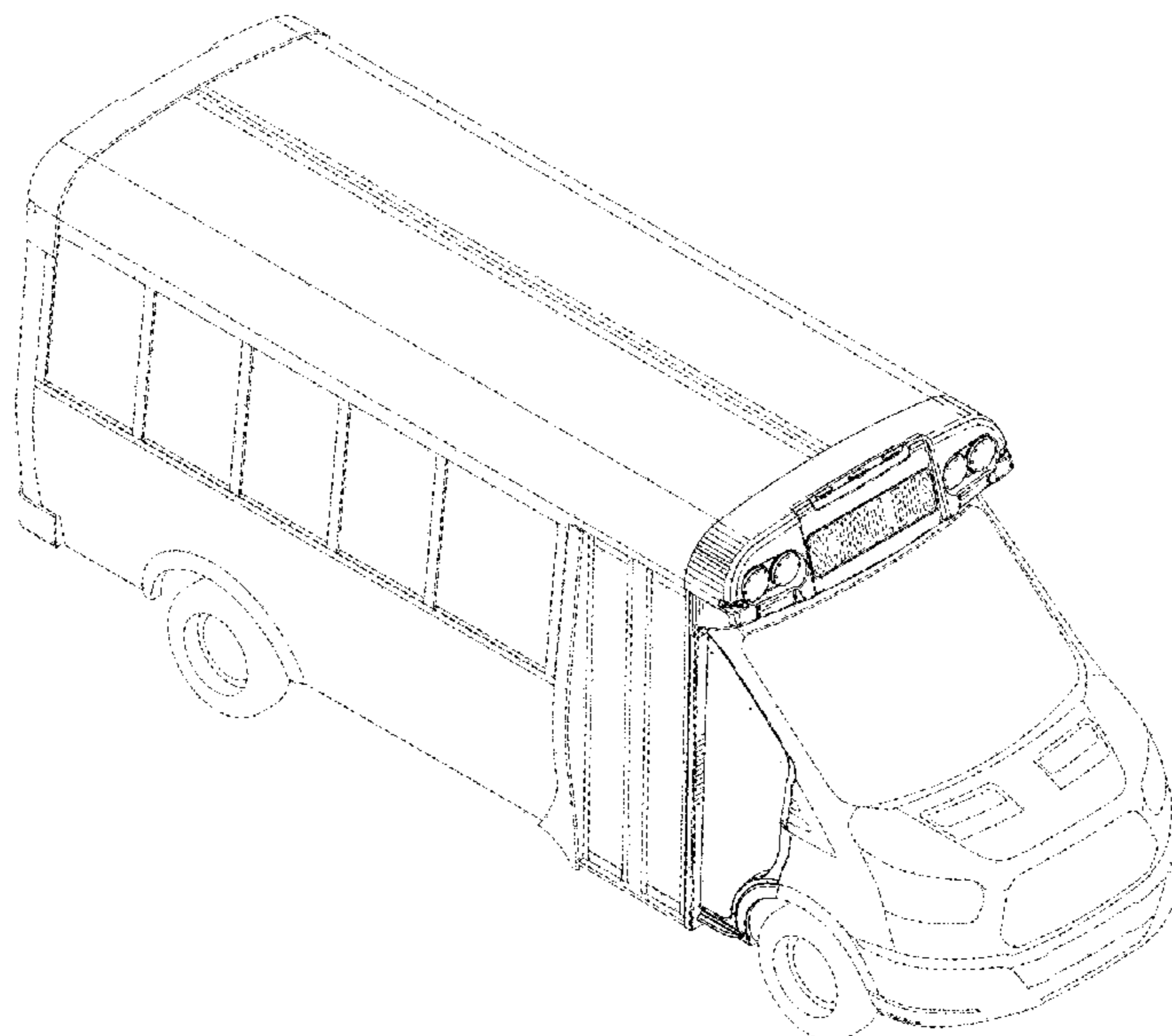

(56)

References Cited

OTHER PUBLICATIONS

- Collins Bus Corporation, Products: Model SL408, <http://www.collinsbuscorp.com/products.php?id=3>.
- Collins Bus Corporation, Products: Model DH400, <http://www.collinsbuscorp.com/products.php?id=4>.
- Collins Bus Corporation, Products: Model DE416, <http://www.collinsbuscorp.com/products.php?id=5>.
- Collins Bus Corporation, Products: Model DH416, <http://www.collinsbuscorp.com/products.php?id=6>.
- Collins Bus Corporation, Products: Model DH416WR, <http://www.collinsbuscorp.com/products.php?id=7>.
- Collins Bus Corporation, Products: Model DH500, <http://www.collinsbuscorp.com/products.php?id=8>.
- Collins Bus Corporation, Products: Model DH516, <http://www.collinsbuscorp.com/products.php?id=9>.
- Collins Bus Corporation, Products: Model DE416WR, <http://www.collinsbuscorp.com/products.php?id=10>.
- Collins Bus Corporation, Products: Model DE516, <http://www.collinsbuscorp.com/products.php?id=11>.
- Collins Bus Corporation, Products: Model DE516WR, <http://www.collinsbuscorp.com/products.php?id=12>.
- Collins Bus Corporation, Products: Model MFSAB, <http://www.collinsbuscorp.com/products.php?id=13>.
- Collins Bus Corporation, Products: Model MPV—Multipurpose Passenger Vehicle, <http://www.collinsbuscorp.com/products.php?id=18>.
- Collins Bus Corporation, Products: Model Compressed Natural Gas—CNG, http://www.collinsbuscorp.com/products_php?id=19.
- Collins Bus Corporation, Products: Model SH408, <http://www.collinsbuscorp.com/products.php?id=20>.

* cited by examiner

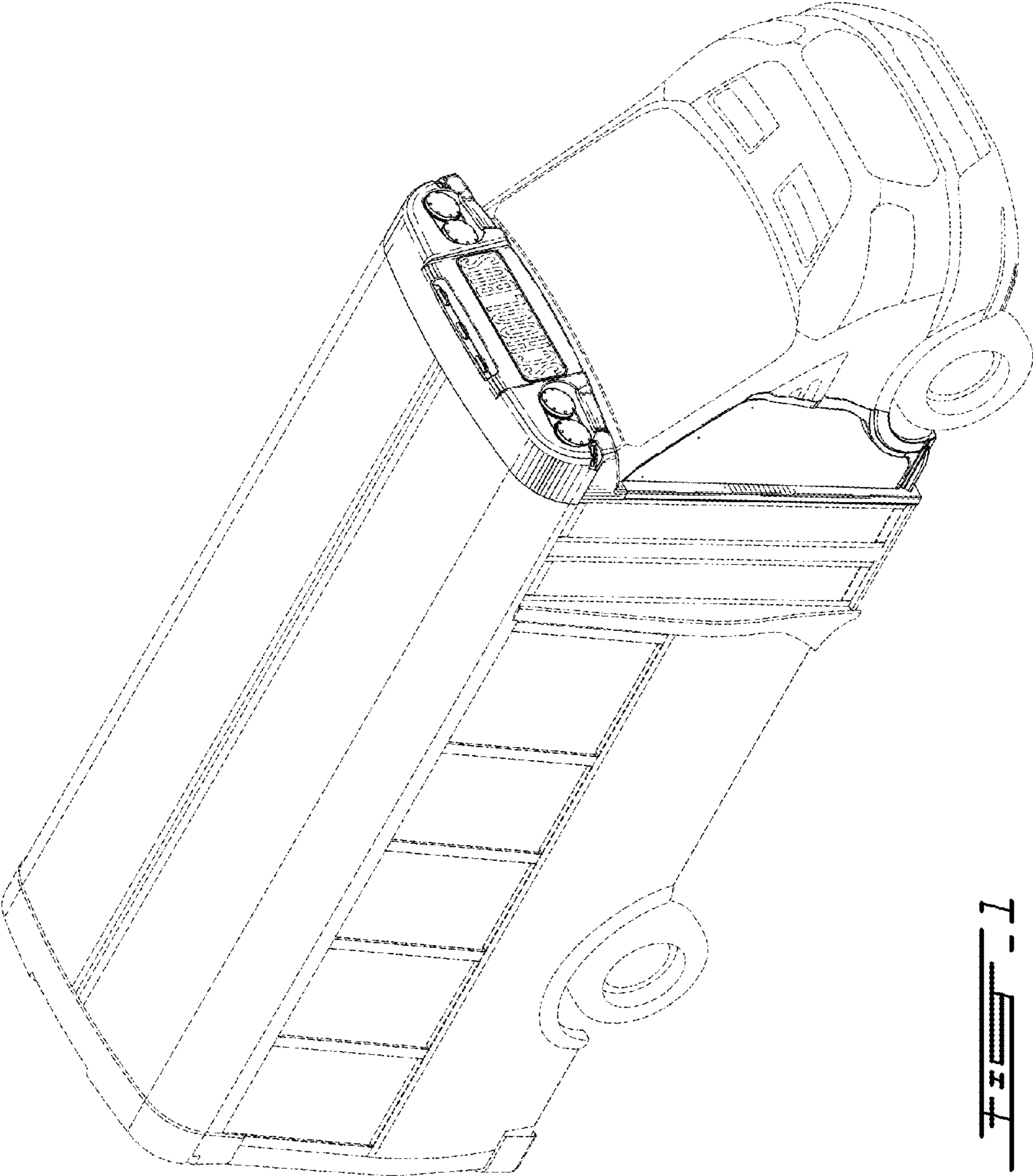

FIG. 1

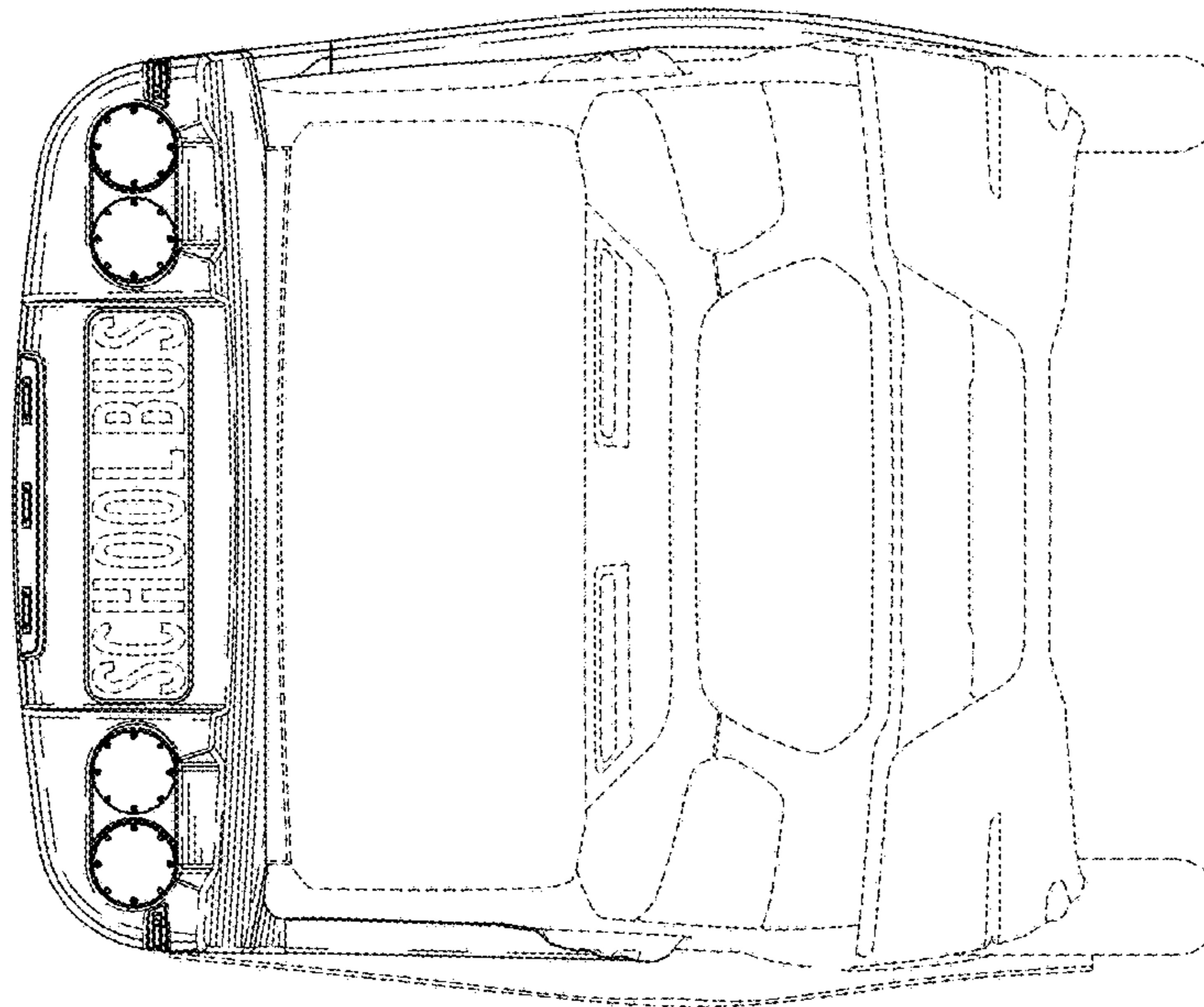

FIG. 2

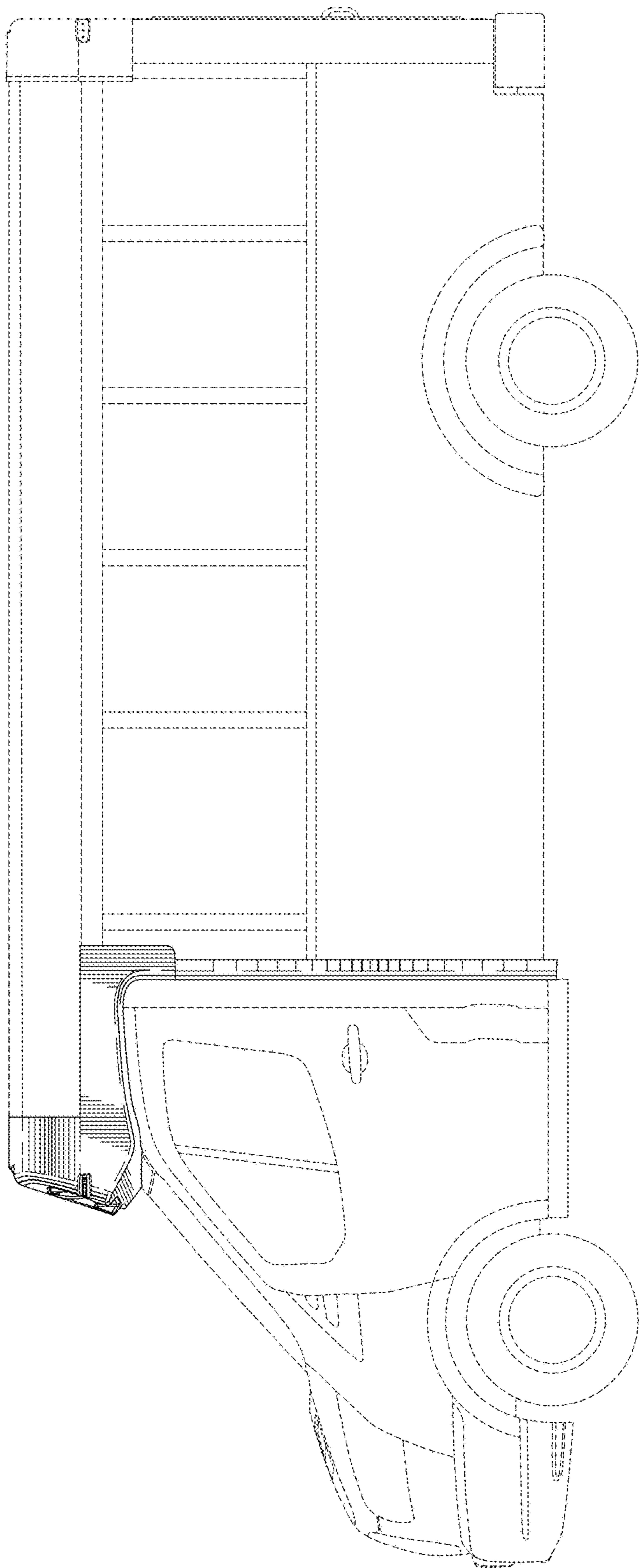

FIG. 3

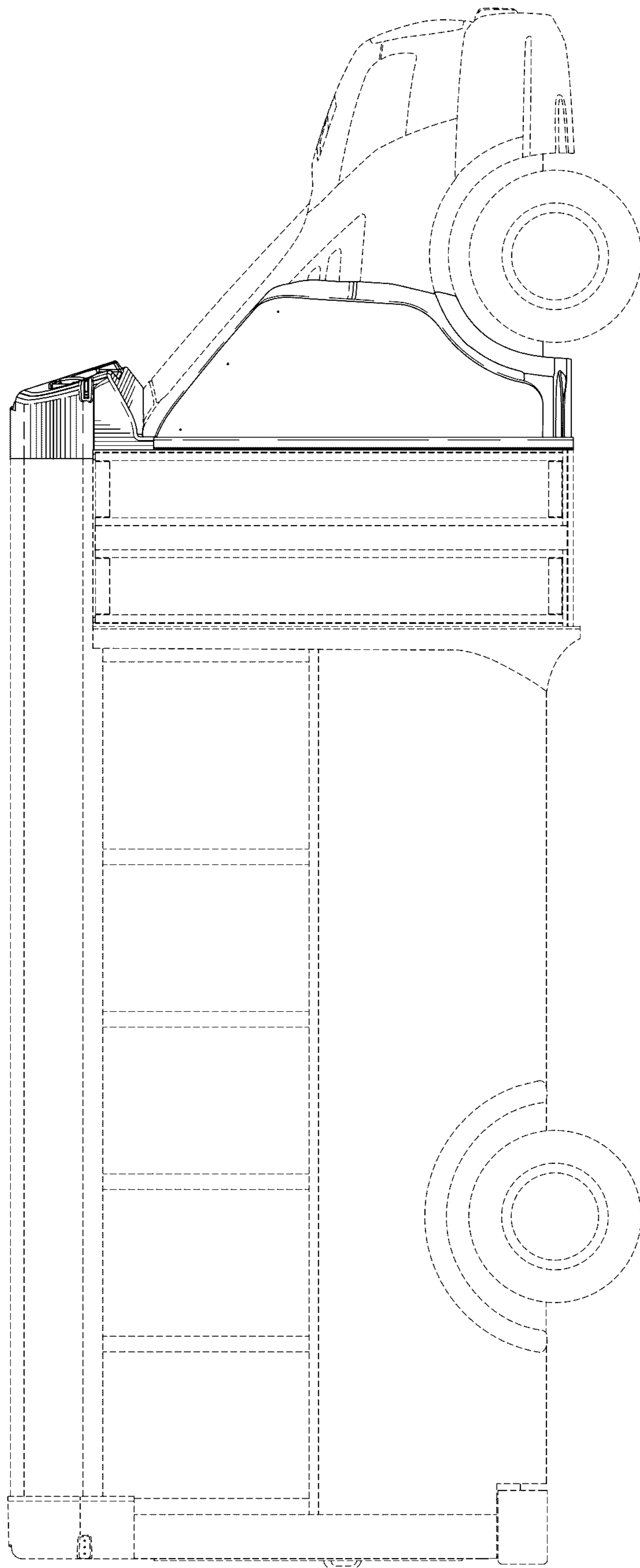

FIG. 4

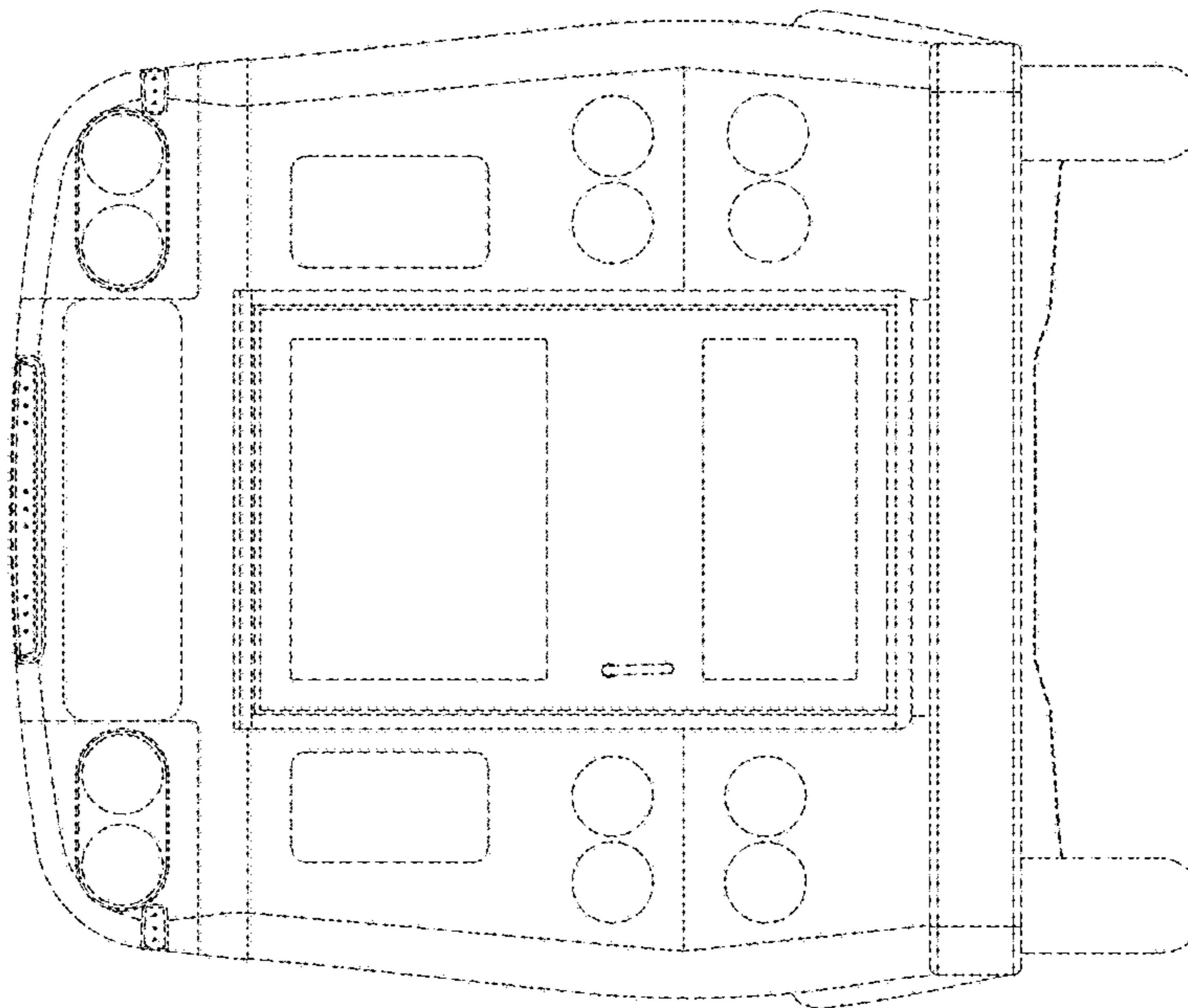

FIG. 5

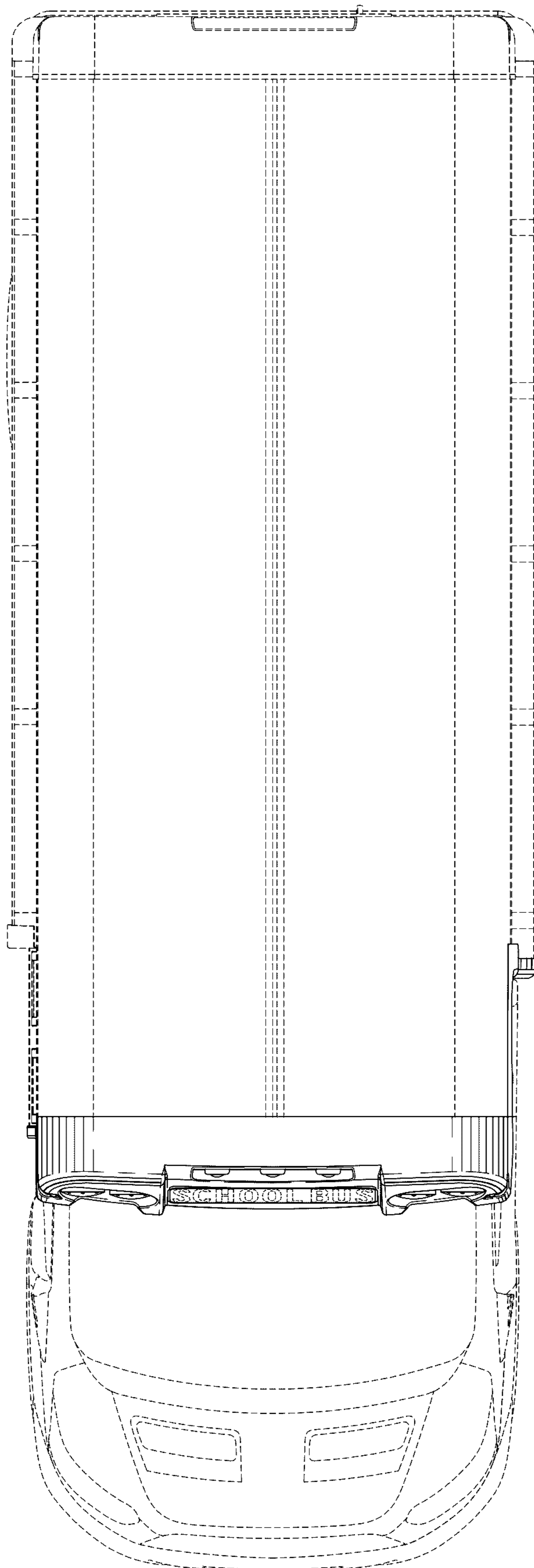

FIG. 6