



US00D775342S

(12) **United States Design Patent** (10) **Patent No.:** **US D775,342 S**
LeBlanc et al. (45) **Date of Patent:** **** Dec. 27, 2016**

(54) **LIQUID-FREE TRAP FOR TRACE LEVEL ACIDIC AND BASIC AMC AND COMPONENTS THEREOF**

(71) Applicant: **Entegris, Inc.**, Billerica, MA (US)

(72) Inventors: **Thomas LeBlanc**, Mendon, MA (US);
John C. Gaudreau, Chepachet, RI (US);
Jürgen M. Lobert, Franklin, MA (US);
Tyler Moulton, Grafton, MA (US)

(73) Assignee: **Entegris, Inc.**, Billerica, MA (US)

(**) Term: **14 Years**

(21) Appl. No.: **29/511,388**

(22) Filed: **Dec. 10, 2014**

(51) **LOC (10) Cl.** **24-00**

(52) **U.S. Cl.**
 USPC **D24/162**

(58) **Field of Classification Search**
 USPC ... D24/162, 164, 219, 110.6, 216; D23/209;
 D15/138; 210/335; 385/104; 96/134
 (Continued)

(56) **References Cited**

U.S. PATENT DOCUMENTS

3,985,017 A 10/1976 Goldsmith
 D320,842 S 10/1991 Roman
 (Continued)

OTHER PUBLICATIONS

Search Report for Taiwan Application No. 104305936, "Liquid-Free Trap for Trace Level Acidic and Basic AMC and Components Thereof", date of completion: Jan. 5, 2016.
 (Continued)

Primary Examiner — Rhea Shields

(74) *Attorney, Agent, or Firm* — John E. Pillion

(57) **CLAIM**

The ornamental design for a liquid-free trap for trace level acidic and basic AMC and components thereof, as shown and described.

DESCRIPTION

FIG. 1 is a front perspective view of the liquid-free trap for trace level acidic and basic AMC and components thereof, according to our new design;
 FIG. 2 is a back perspective view thereof;
 FIG. 3 is a front view thereof;
 FIG. 4 is a back view thereof;
 FIG. 5 is a top view thereof;
 FIG. 6 is a top sectional view taken on line 6-6 of FIG. 5.
 FIG. 7 is an exploded view of FIG. 5.
 FIG. 8 is a front perspective view of locking nut member of the liquid-free trap;
 FIG. 9 is a back perspective view thereof;
 FIG. 10 is a front view thereof;
 FIG. 11 is a back view thereof;
 FIG. 12 is a top view thereof; and,
 FIG. 13 is a top sectional view taken on line 13-13 of FIG. 12.

In the drawings, the broken lines are for the purpose of illustrating environment only and form no part of the claimed design.

The liquid-free trap for trace level acidic and basic AMC and components thereof in the present invention relies on a solid material to trap acidic or basic AMC in a gas stream, for example, from a cleanroom or a semiconductor manufacturing facility. The liquid-free trap for trace level acidic and basic AMC and components thereof can be used in any suitable orientation, including horizontal and vertical orientations. The liquid-free trap for trace level acidic and basic AMC and components thereof can comprise a housing comprising a hollow, elongate upstream component with tubular portions; a hollow, elongate downstream component with tubular portions; and a locking nut member to secure the upstream component to the downstream component, the upstream component and the downstream component together creating a chamber space that is sealed from the

(Continued)

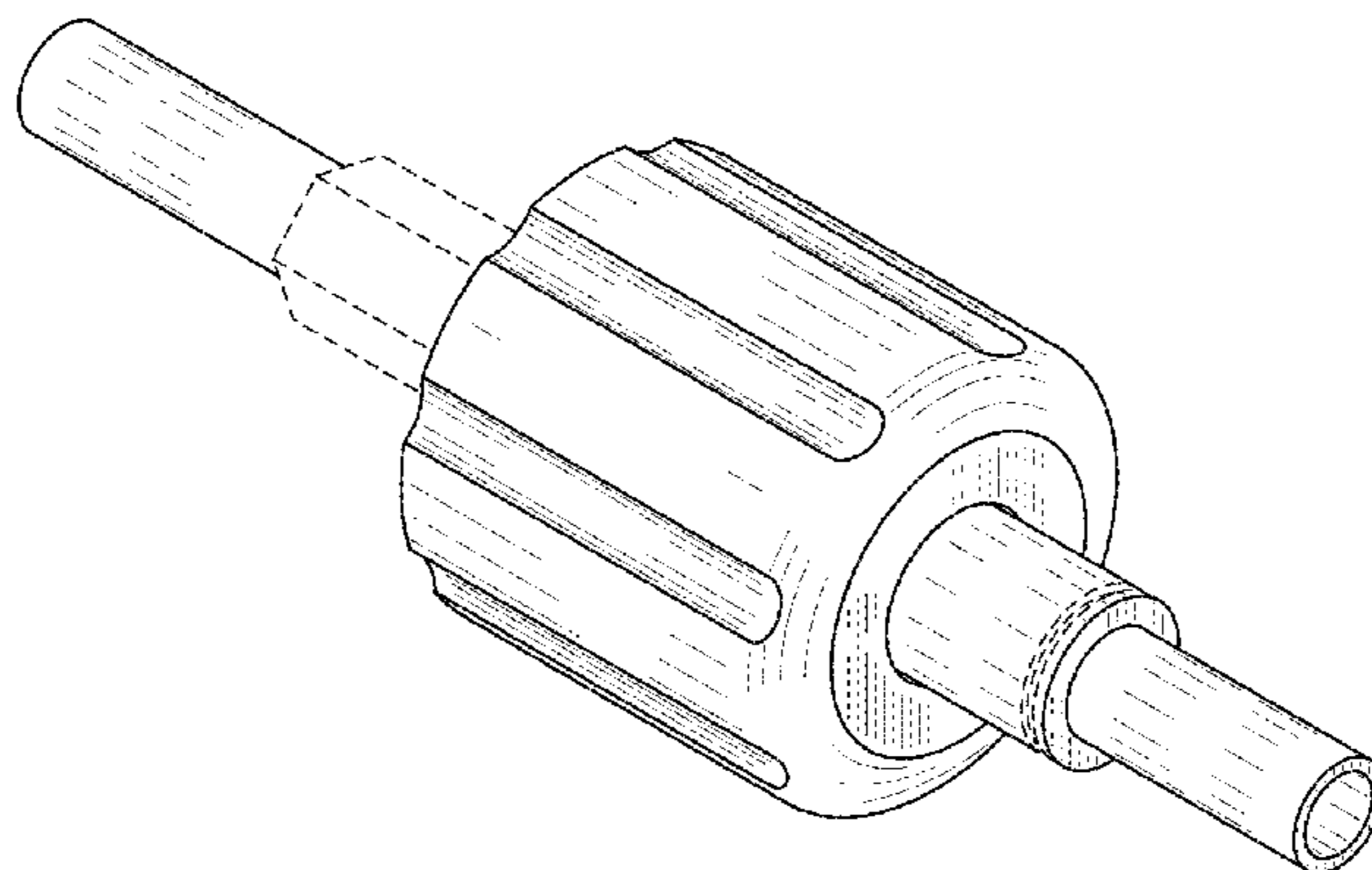

environment and situated in a flow path between the inlet and the outlet. The space created by the upstream and downstream components together can accommodate a rigid sintered hydrophilic material trap member for trapping trace level acidic or basic AMC.

1 Claim, 5 Drawing Sheets

(58) Field of Classification Search

CPC B01D 27/07; G02B 6/4432; G01D 11/245; B01J 20/18

See application file for complete search history.

(56) References Cited

U.S. PATENT DOCUMENTS

5,302,191	A	4/1994	Koutrakis	
D473,633	S	4/2003	Chun-Lee	
D543,948	S	6/2007	Montena	
7,247,245	B1 *	7/2007	Proulx B01D 27/07 210/335
7,430,893	B2	10/2008	Grafer et al.	
D620,075	S *	7/2010	Yamaguchi D23/209
D636,878	S *	4/2011	Lee D24/162
D682,497	S *	5/2013	Wargo D15/138
D693,001	S *	11/2013	Winter D24/110.6
D693,467	S *	11/2013	Doucette D24/162
D694,423	S *	11/2013	Klein D24/219
D695,415	S *	12/2013	Hwang D24/219
D717,462	S *	11/2014	Wainwright D24/216
9,134,146	B2 *	9/2015	Baum G01D 11/245
D740,391	S *	10/2015	Mueller D23/209

D743,034	S *	11/2015	Ebi D24/162
2009/0324182	A1 *	12/2009	Kachmar G02B 6/4432 385/104
2015/0298040	A1 *	10/2015	Nozaki B01J 20/18 96/134

OTHER PUBLICATIONS

Search Report for Taiwan Application No. 103307311, "Liquid-Free Trap for Trace Level Acidic and Basic AMC and Components Thereof", date of completion: Jul. 9, 2015.

Moulton, T.M., et al., "An analytical method for the measurement of trace level acidic and basic AMC using liquid-free sample traps", *Proc. of SPIE*, vol. 9050 90502B-1-90502B-14 (2014).

Notification of Transmittal of the International Search Report and the Written Opinion of the International Searching Authority, or the Declaration for International Application No. PCT/US2014/054266, "Liquid-Free Sample Traps and Analytical Method for Measuring Trace Level Acidic and Basic AMC"; date of mailing: Apr. 7, 2015. 2012 Parts Catalog Ordering Information Terms and Conditions, Dec. 31, 2012, <http://www.urgcorp.com/lobrary/catalogs/URG%20cATALOG%202012.pdf>.

Chow, J., et al., "A Sampling System for Reactive Species in the Western United States", *Sampling and Analysis of Airborne Pollutants*, pp. 210-228 (1993).

Metrology, Inspection, and Process Control for Microlithography XXVIII, *Proceedings of SPIE* 0277-0786X v. 9050, Feb. 24-27, 2014.

International Preliminary Report on Patentability for International Application No. PCT/US2014/054266, "Liquid-Free Sample Traps and Analytical Method for Measuring Trace Level Acidic and Basic AMC"; Date mailed: Mar. 17, 2016.

* cited by examiner

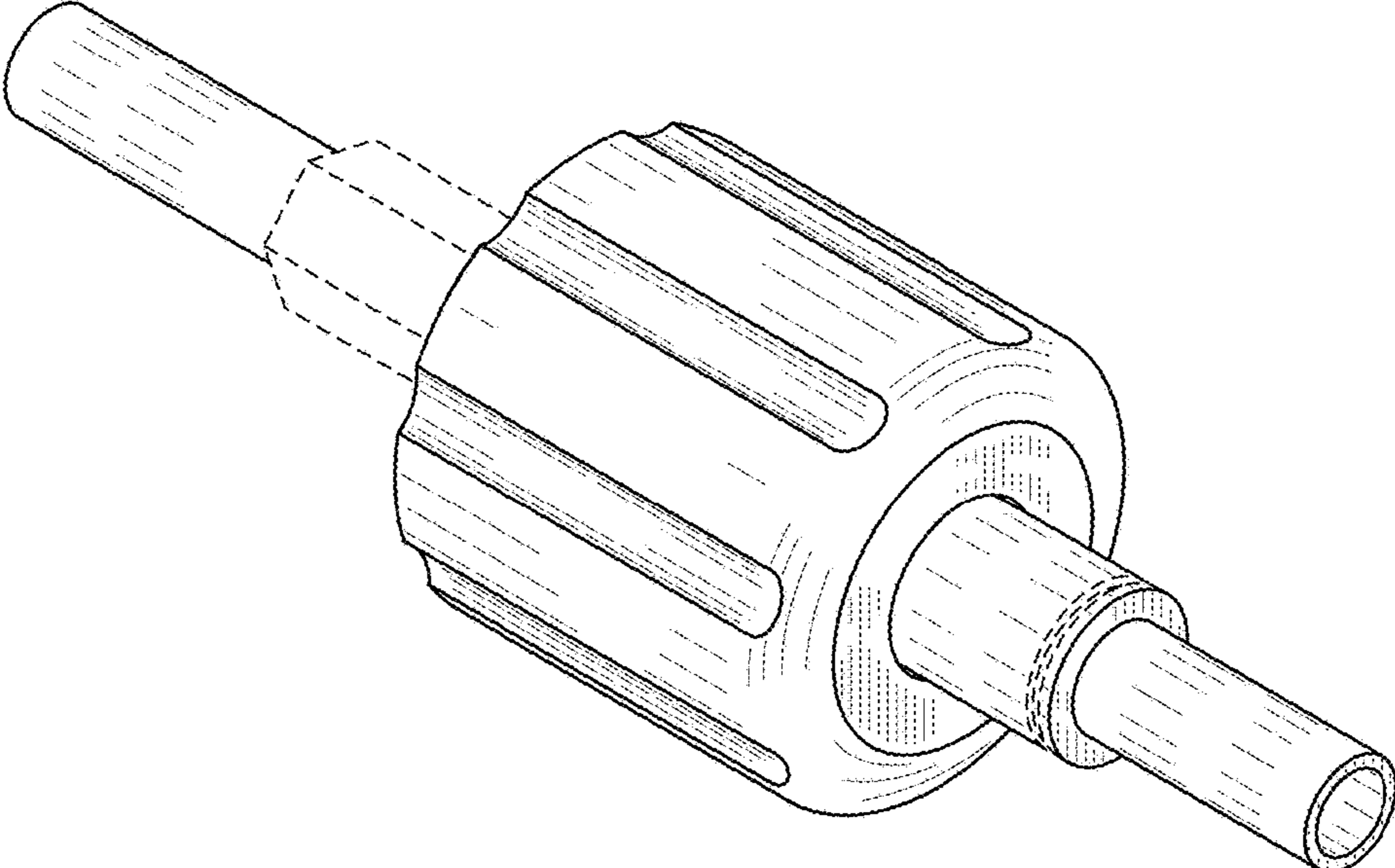

FIG. 1

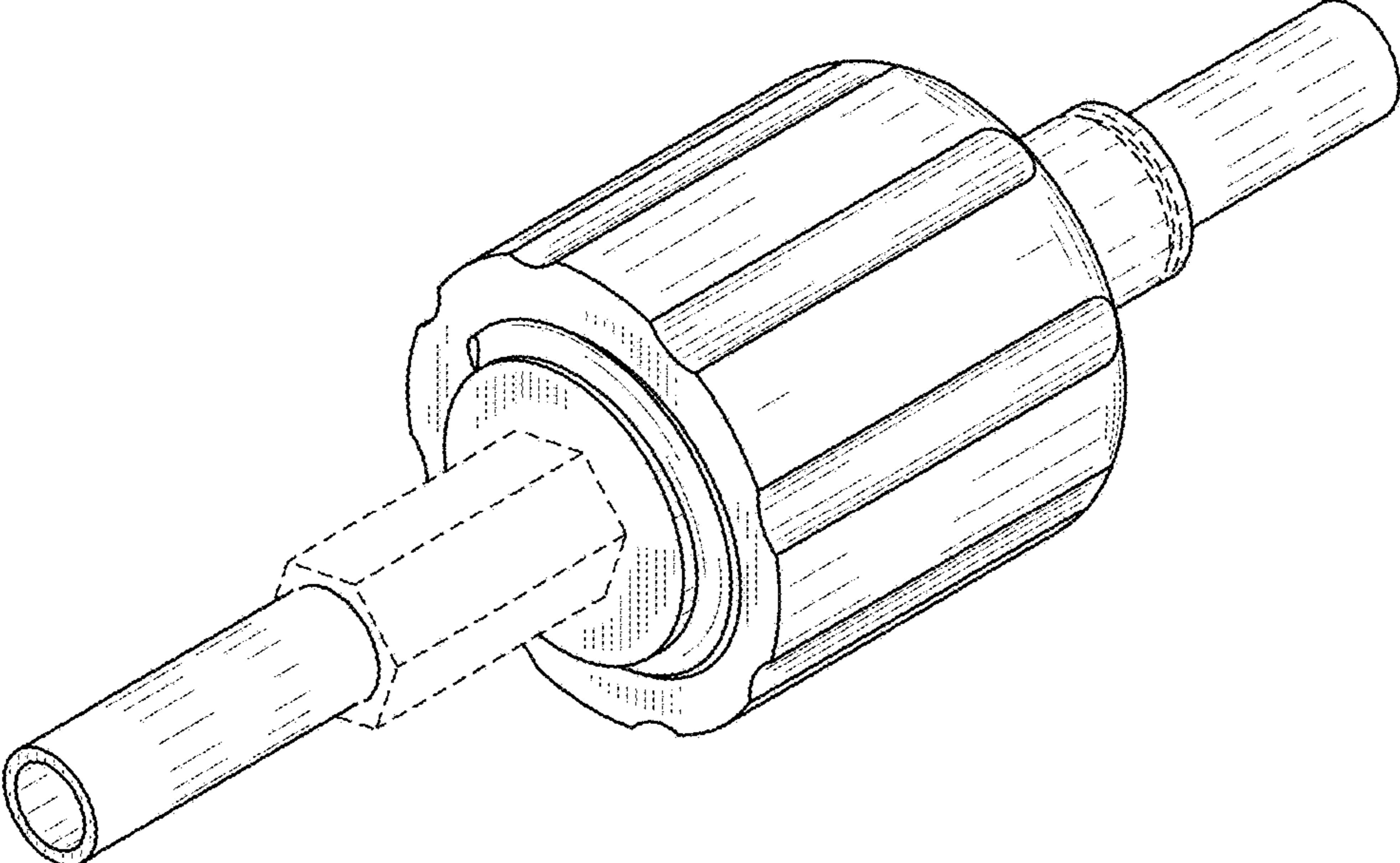

FIG. 2

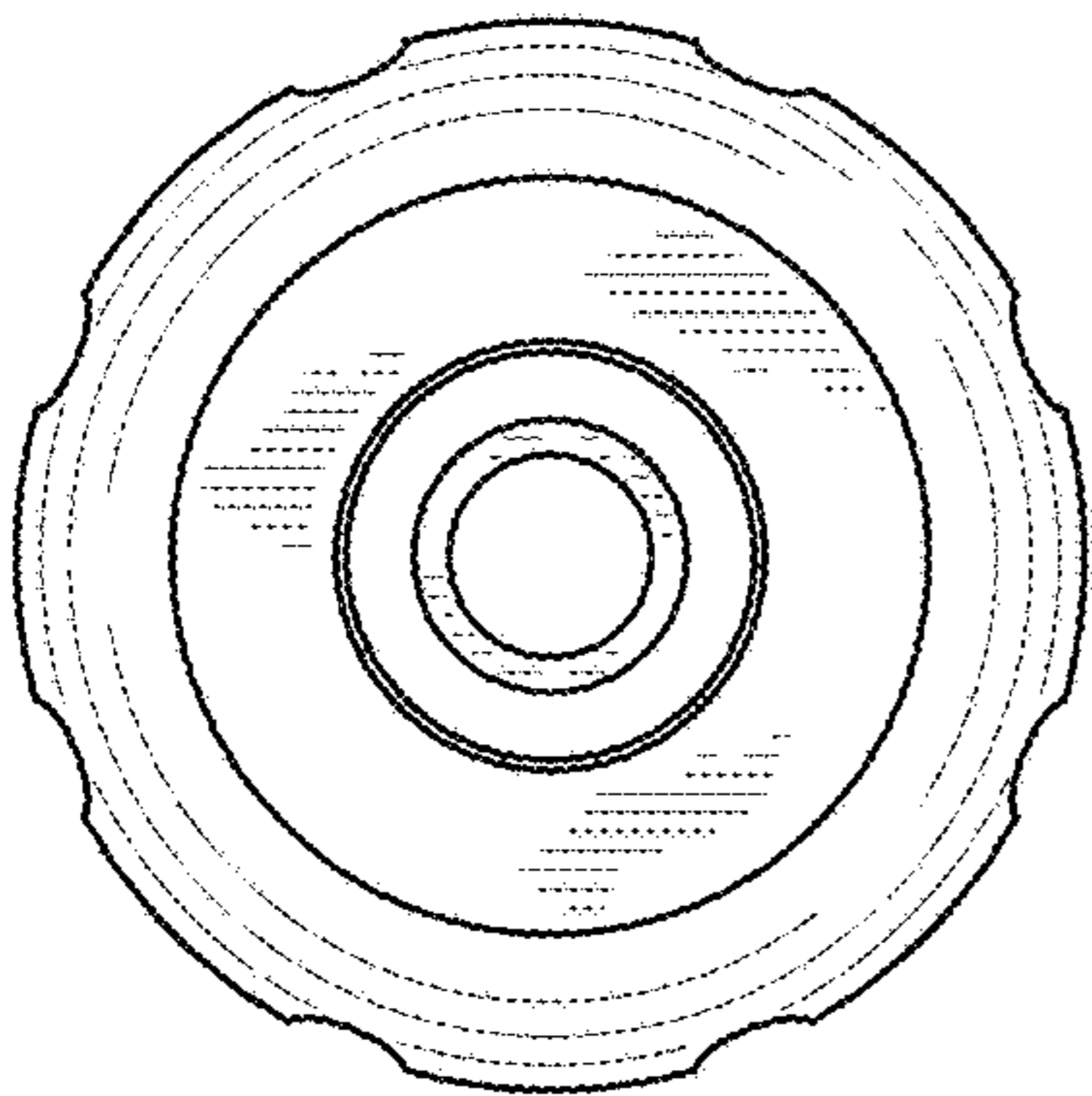

FIG. 3

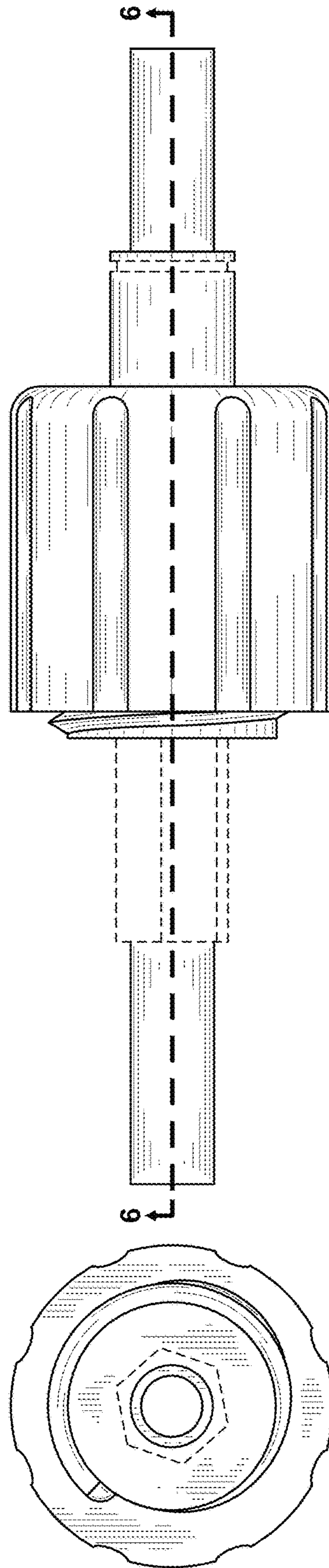

FIG. 4

FIG. 5

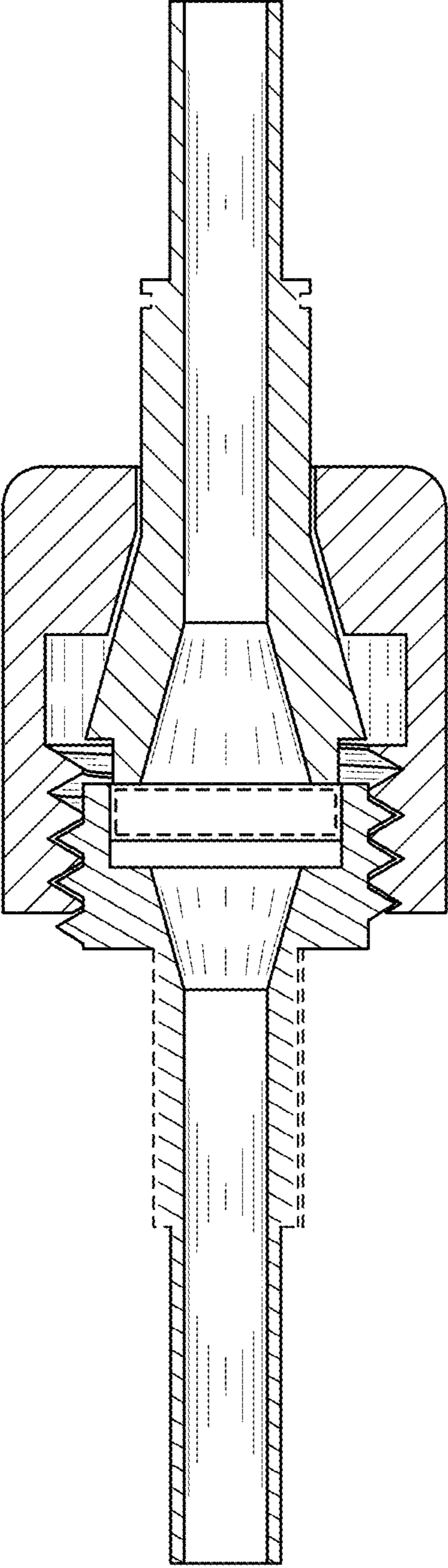

FIG. 6

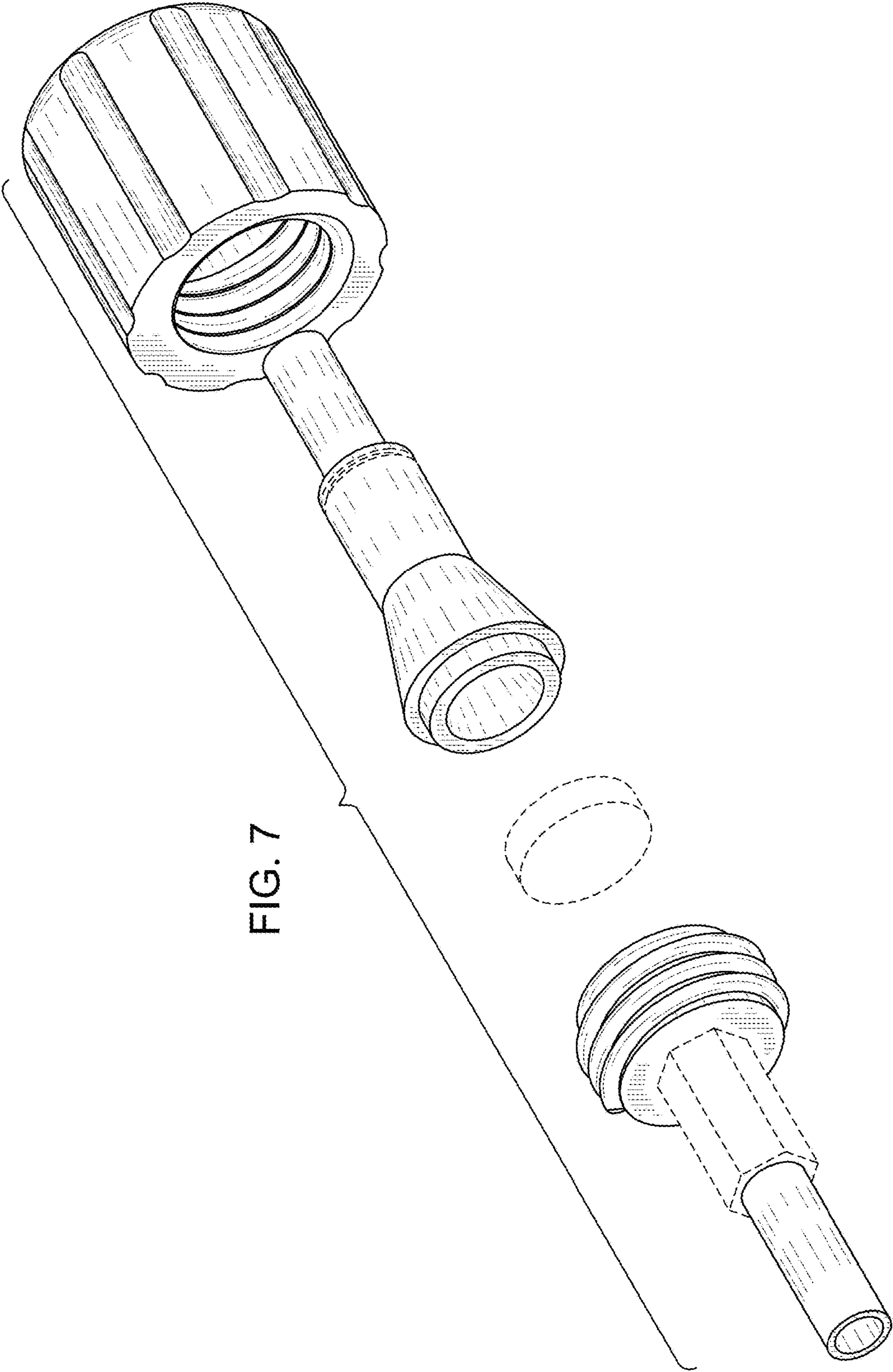

FIG. 7

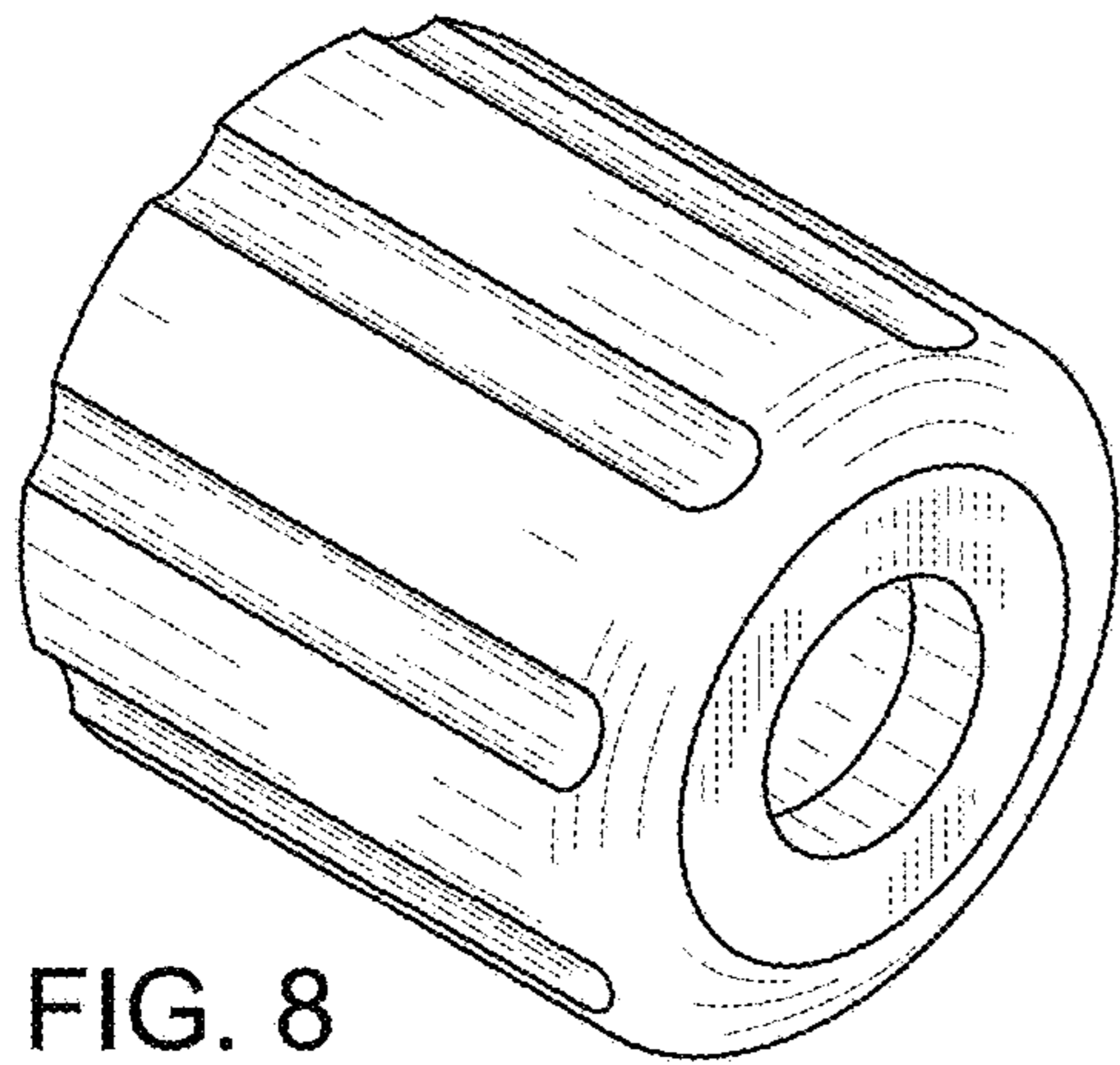

FIG. 8

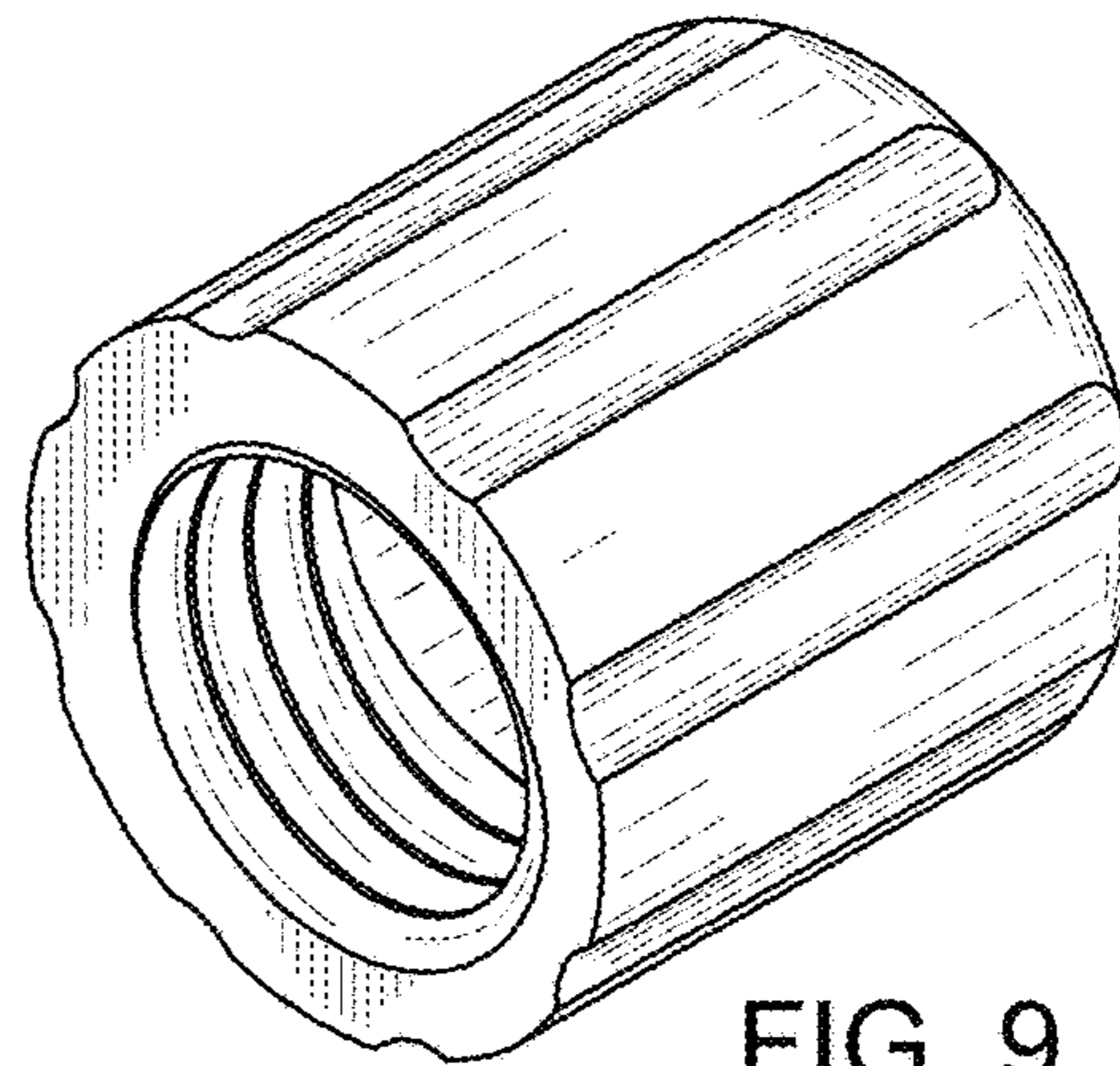

FIG. 9

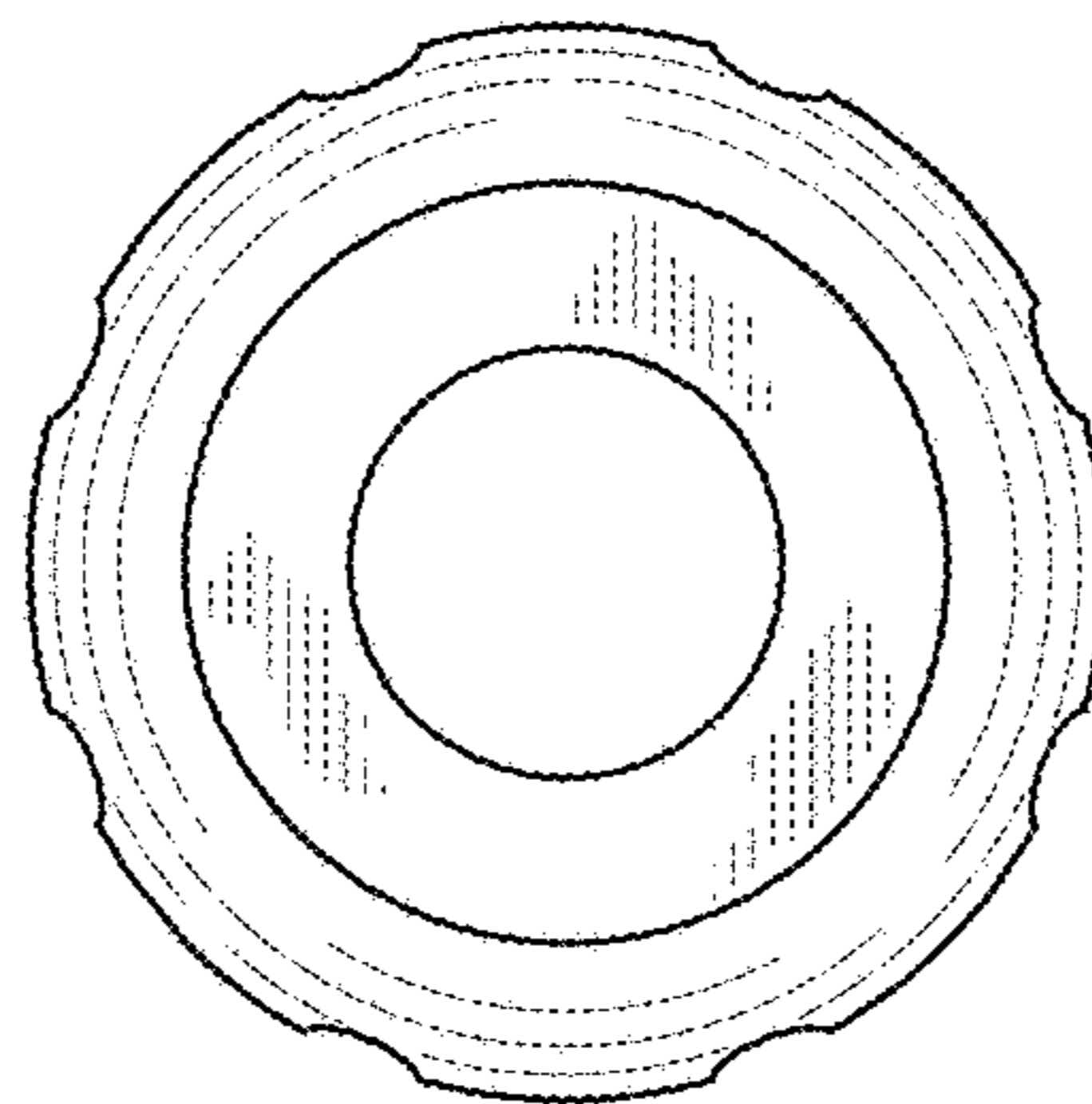

FIG. 10

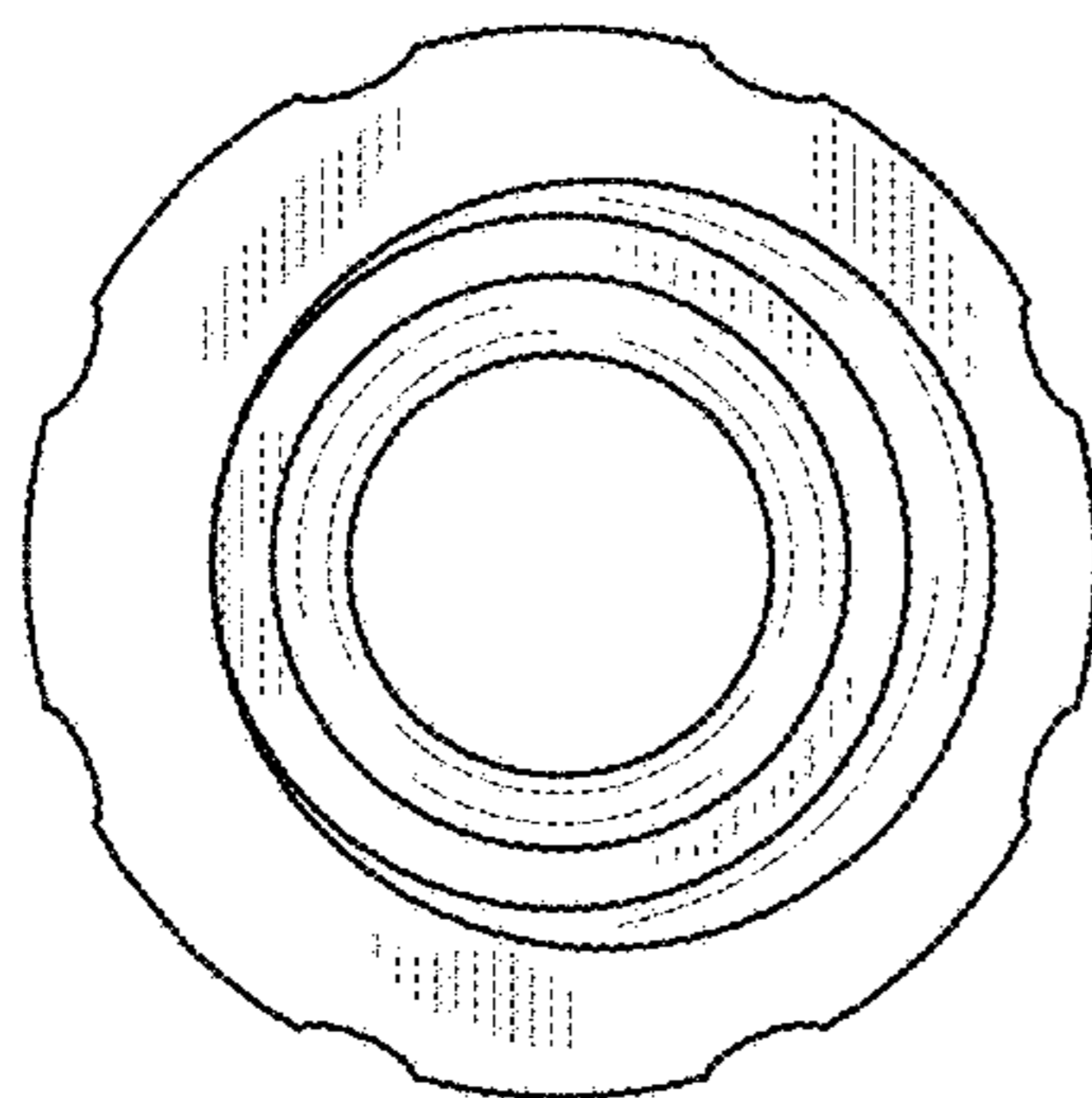

FIG. 11

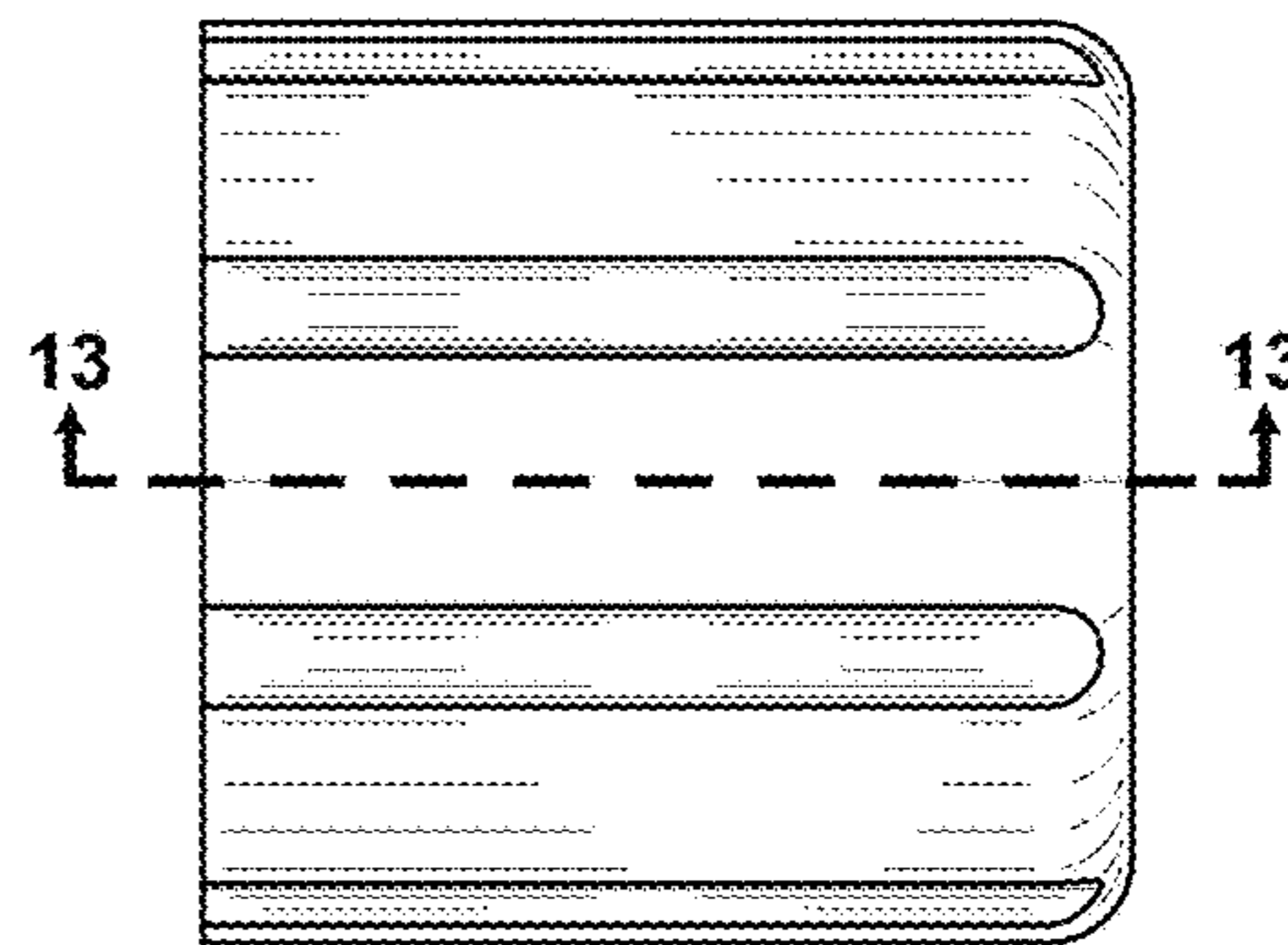

FIG. 12

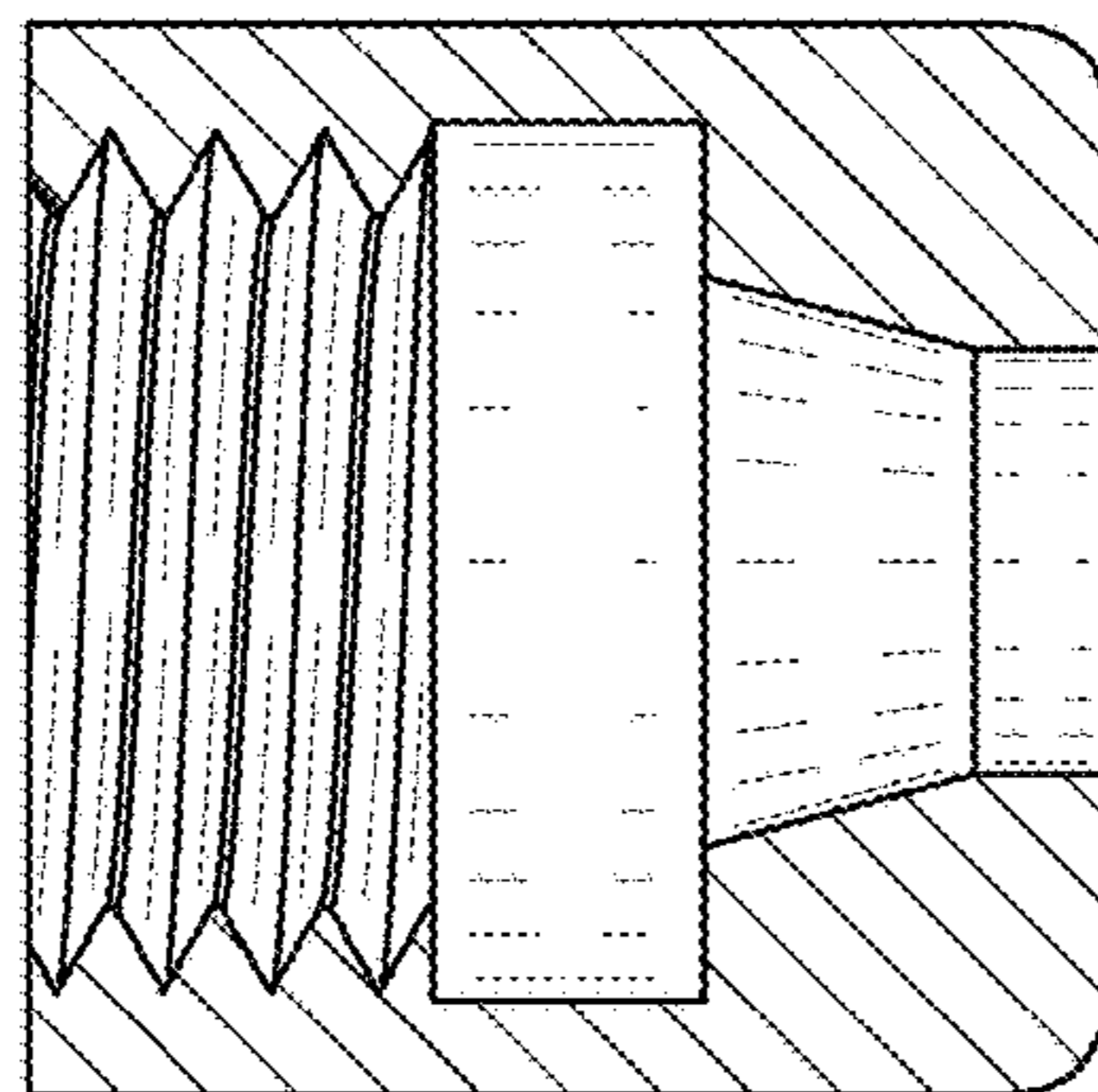

FIG. 13