



US00D775128S

(12) **United States Design Patent** (10) **Patent No.:** **US D775,128 S**
Zellweger et al. (45) **Date of Patent:** **** Dec. 27, 2016**

(54) **HEAD MOUNTED DISPLAY**
(71) Applicant: **HTC CORPORATION**, Taoyuan (TW)
(72) Inventors: **Claude Zellweger**, San Francisco, CA (US); **Brent Edward Barberis**, San Francisco, CA (US); **Catherine Sayim Kim**, San Francisco, CA (US); **Carl Samuel Conlee, IV**, San Francisco, CA (US); **Benjamin Kai Norman Robertson**, San Francisco, CA (US)
(73) Assignee: **HTC Corporation**, Taoyuan (TW)
(**) Term: **15 Years**
(21) Appl. No.: **29/568,665**
(22) Filed: **Jun. 20, 2016**

Related U.S. Application Data

(60) Division of application No. 29/537,091, filed on Aug. 21, 2015, now Pat. No. Des. 761,258, which is a continuation-in-part of application No. 29/517,944, filed on Dec. 18, 2015, now Pat. No. Des. 763,256.

Foreign Application Priority Data

Aug. 17, 2015 (TW) 104304464

(51) **LOC (10) Cl.** **14-02**

(52) **U.S. Cl.**
USPC **D14/372**

(58) **Field of Classification Search**
USPC D14/372, 496, 432, 371, 125, 126, 129, D14/299; D16/300-342; 351/158, 153, 351/144; 345/7-9, 905; 455/344; 348/115, 348/53, 121, 739
CPC G02B 27/017; G02B 27/0158; G02B 27/0161; G02B 27/0181; G02B 27/0185; G02B 27/0189

See application file for complete search history.

(56) **References Cited**

U.S. PATENT DOCUMENTS

D338,514 S 8/1993 Holmes
D363,482 S 10/1995 Robinson et al.
D369,595 S 5/1996 Kober et al.

(Continued)

FOREIGN PATENT DOCUMENTS

JP 1502748 S 7/2015
JP 1536193 S 10/2015

(Continued)

OTHER PUBLICATIONS

Chacos, "Move over, Oculus: HTC announces SteamVR-powered Vive VR headset", published on Mar. 1, 2015. <http://www.pcworld.com/article/2890341/move-over-oculus-htc-announces-steamvr-powered-vive-vr-head>.

(Continued)

Primary Examiner — Austin Murphy

(74) *Attorney, Agent, or Firm* — Birch, Stewart, Kolasch & Birch, LLP

(57) **CLAIM**

The ornamental design for head mounted display, as shown and described.

DESCRIPTION

FIG. 1 is a front perspective view of a head mounted display in accordance with our new design; FIG. 2 is a front view thereof; FIG. 3 is a rear view thereof; FIG. 4 is a left side view thereof; FIG. 5 is a right side view thereof; FIG. 6 is a top plan view thereof; FIG. 7 is a bottom plan view thereof; and, FIG. 8 is a rear perspective view thereof. The broken lines throughout the views form no part of the claimed design.

1 Claim, 8 Drawing Sheets

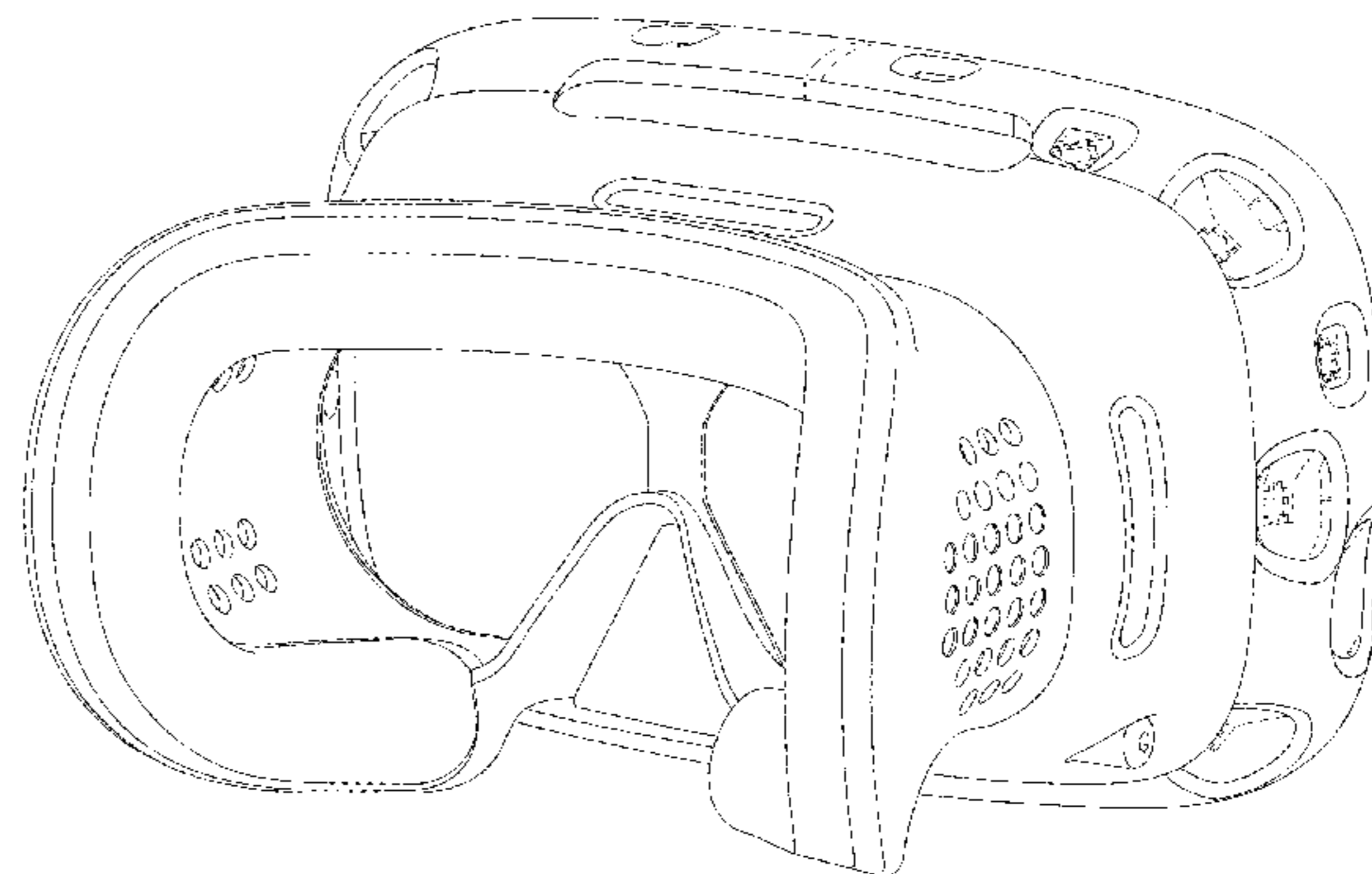
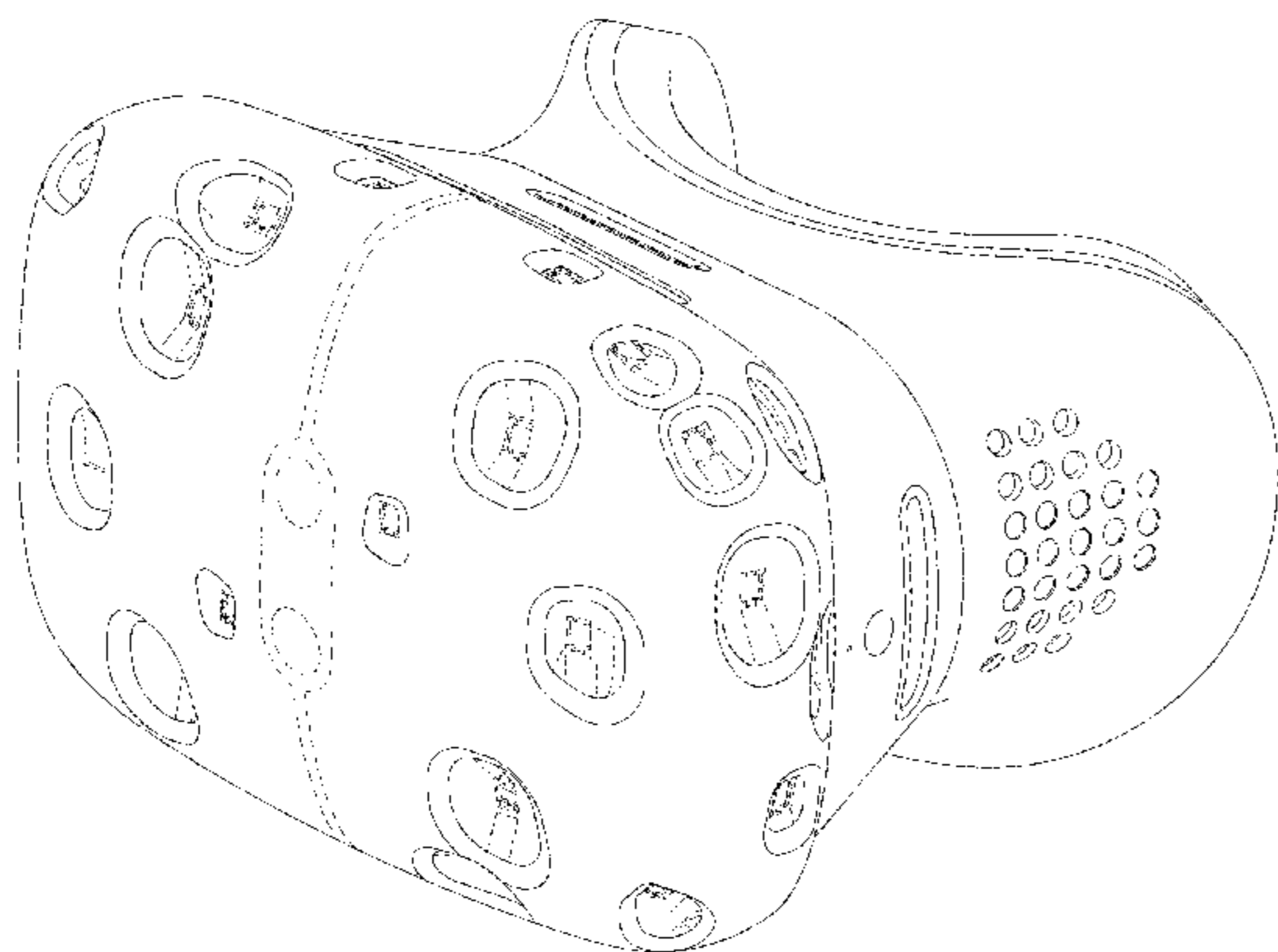

(56)

References Cited

U.S. PATENT DOCUMENTS

D375,495 S 11/1996 MacIness et al.
 D415,146 S 10/1999 Hori
 D440,967 S 4/2001 Jung
 D645,862 S 9/2011 Paul
 D669,471 S 10/2012 Hwang et al.
 D687,434 S 8/2013 Serota
 D701,206 S 3/2014 Luckey et al.
 D704,706 S 5/2014 Serota
 D719,953 S 12/2014 Nokuo et al.
 D727,318 S * 4/2015 Garcia Marin D14/372
 D732,028 S * 6/2015 Kim D14/372
 D738,374 S 9/2015 Luckey et al.
 D739,855 S 9/2015 Bosveld et al.
 D740,810 S 10/2015 Bosveld et al.
 D740,815 S 10/2015 Bosveld et al.
 D741,323 S * 10/2015 Bosveld D14/372
 D741,324 S 10/2015 Bosveld et al.
 D741,327 S * 10/2015 Reznik D14/372
 D741,858 S 10/2015 Bosveld et al.
 D749,580 S * 2/2016 Kim D14/372
 D749,583 S * 2/2016 Luckey D14/372
 D750,074 S * 2/2016 Coz D14/372
 D751,072 S * 3/2016 Lyons D14/372

D753,111 S * 4/2016 Fei D14/372
 D753,112 S * 4/2016 Fei D14/372
 D753,113 S * 4/2016 Fei D14/372
 D759,654 S * 6/2016 Sullivan D14/372
 D761,258 S * 7/2016 Zellweger D14/372
 D763,256 S * 8/2016 Zellweger D14/372
 D764,466 S * 8/2016 Kim D14/372
 D765,658 S * 9/2016 Spio D14/372
 D766,896 S * 9/2016 Li D14/372

FOREIGN PATENT DOCUMENTS

JP 1536194 S 10/2015
 TW D169753 S 8/2015

OTHER PUBLICATIONS

D’Orazio et al., “Valve’s VR headset is called the Vive and it’s made by HTC”, published on Mar. 1, 2015. <http://www.theverge.com/2015/3/1/8127445/htc-vive-valve-vr-headset>.
 Hillier, “HTC, Valve partner for Vive VR headset”, published on Mar. 1, 2015. <http://www.vg247.com/2015/03/01/steamvr-vive-htc-valve-virtual-reality/>.

* cited by examiner

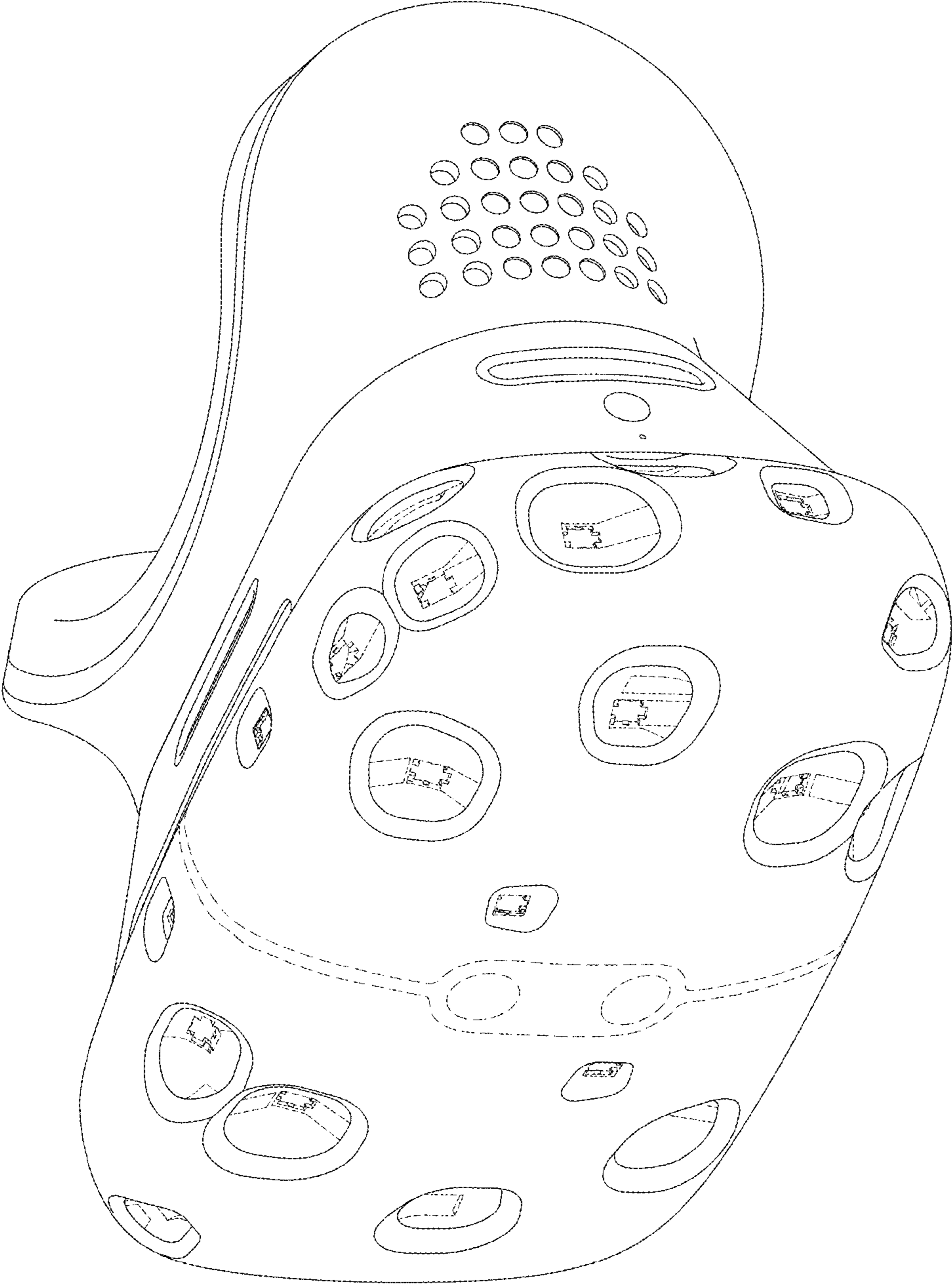

FIG. 1

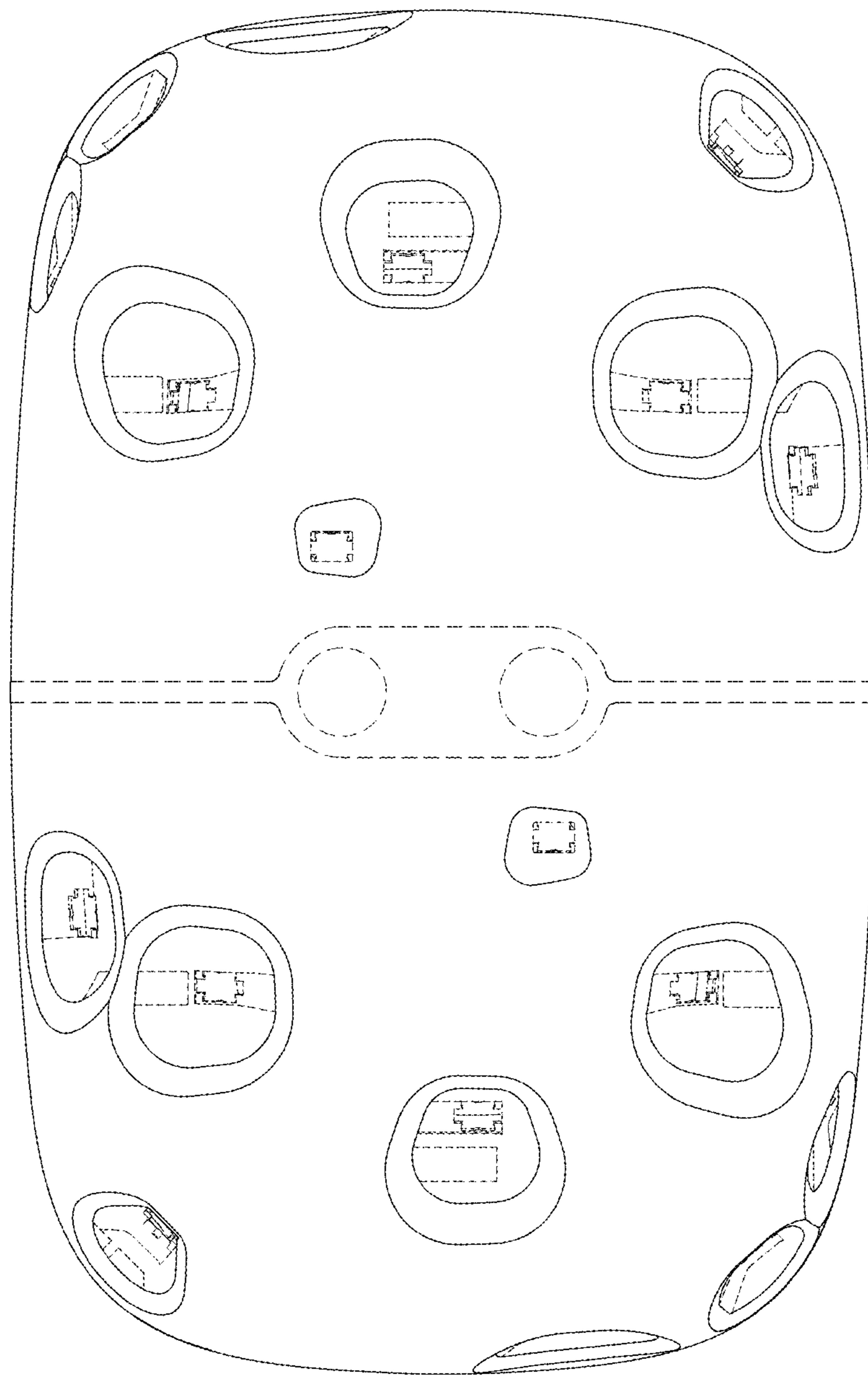

FIG. 2

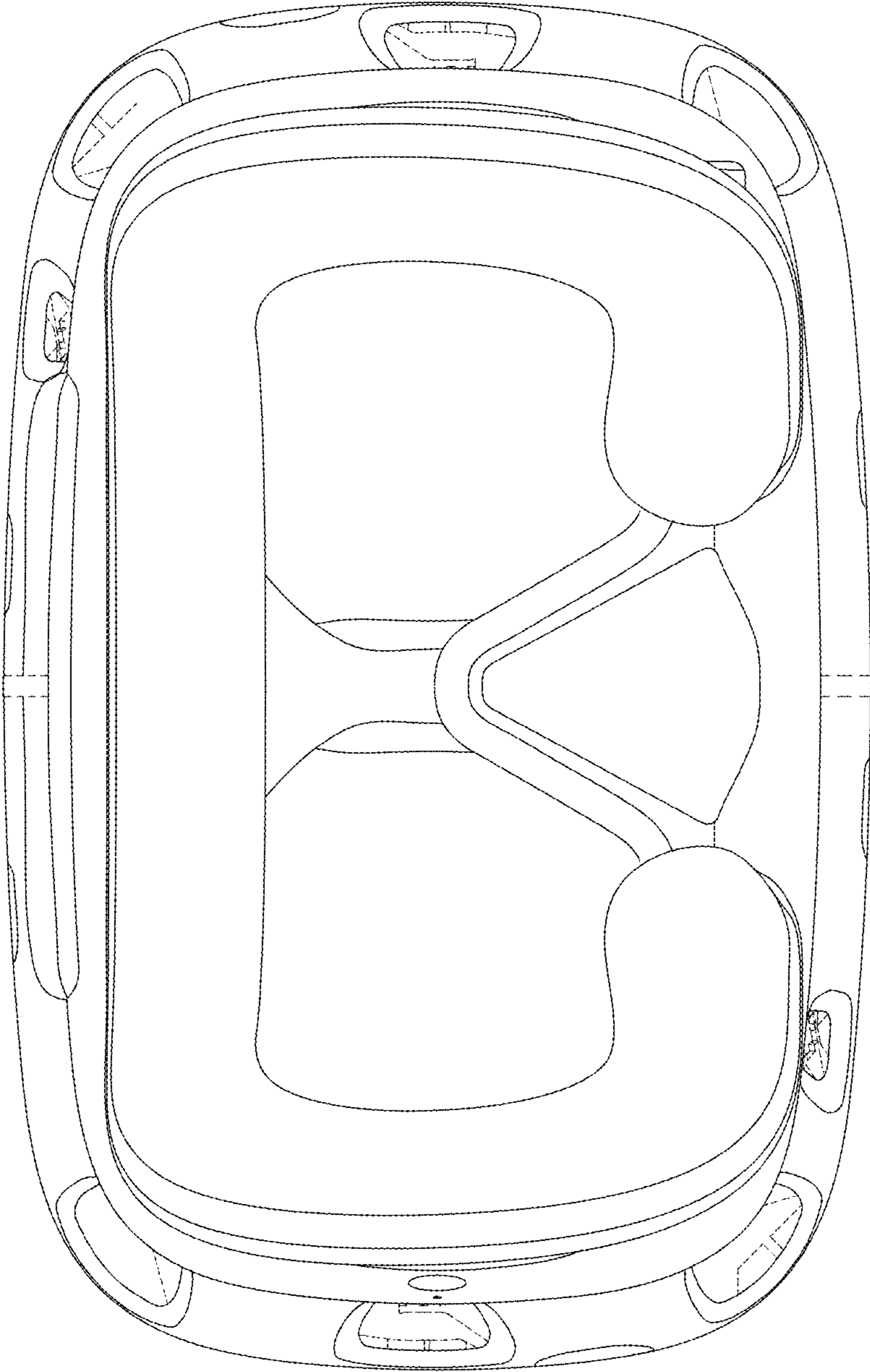

FIG. 3

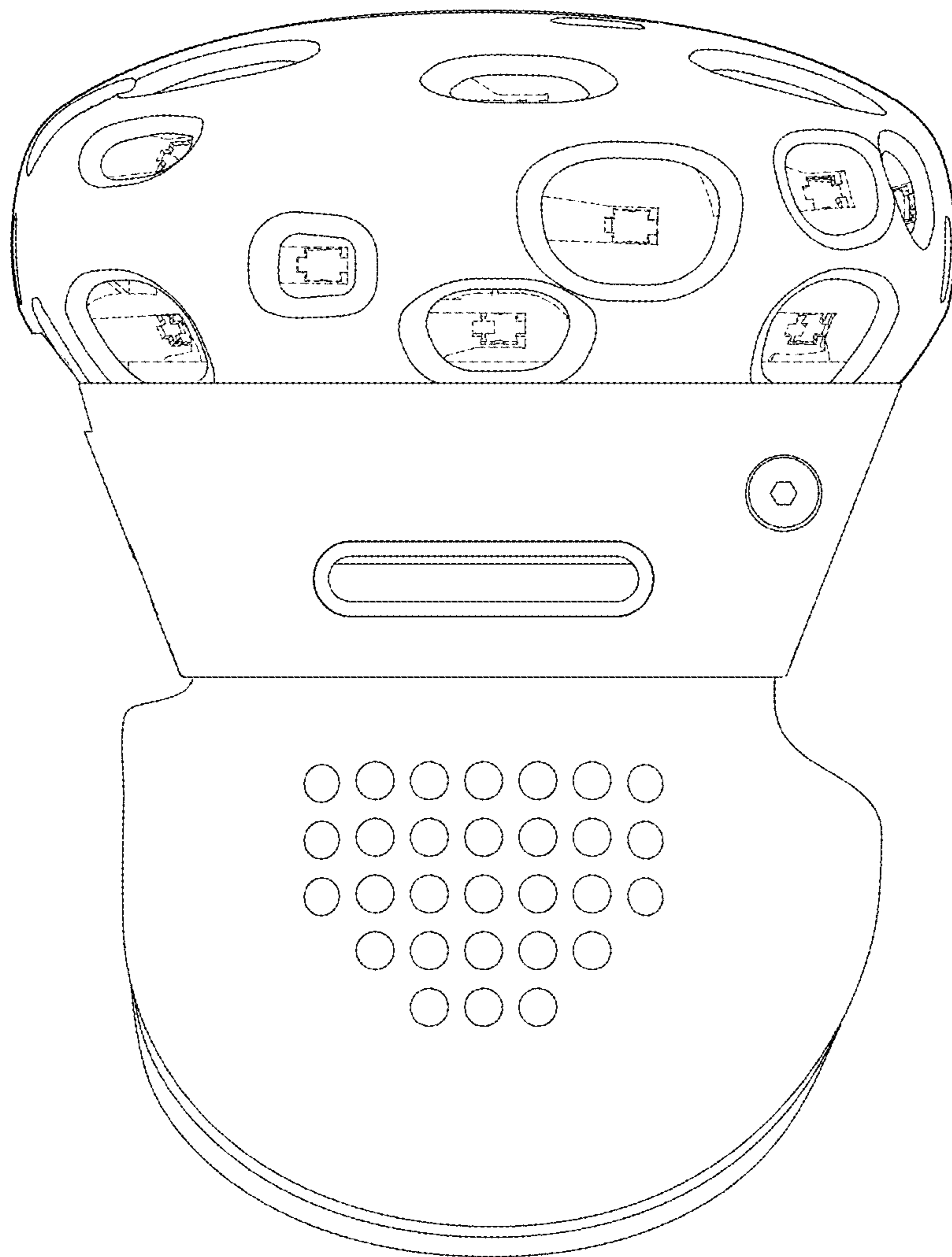

FIG. 4

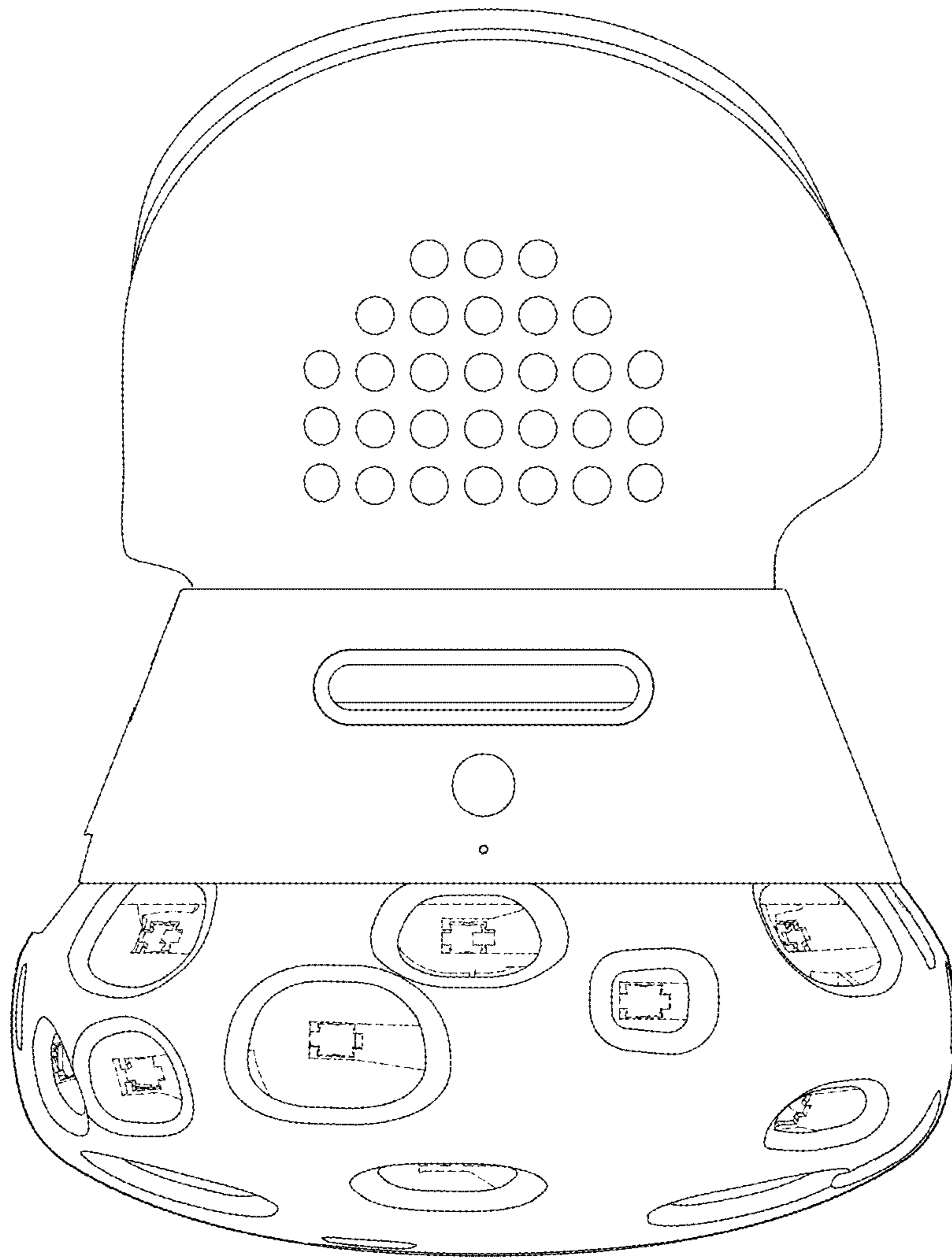

FIG. 5

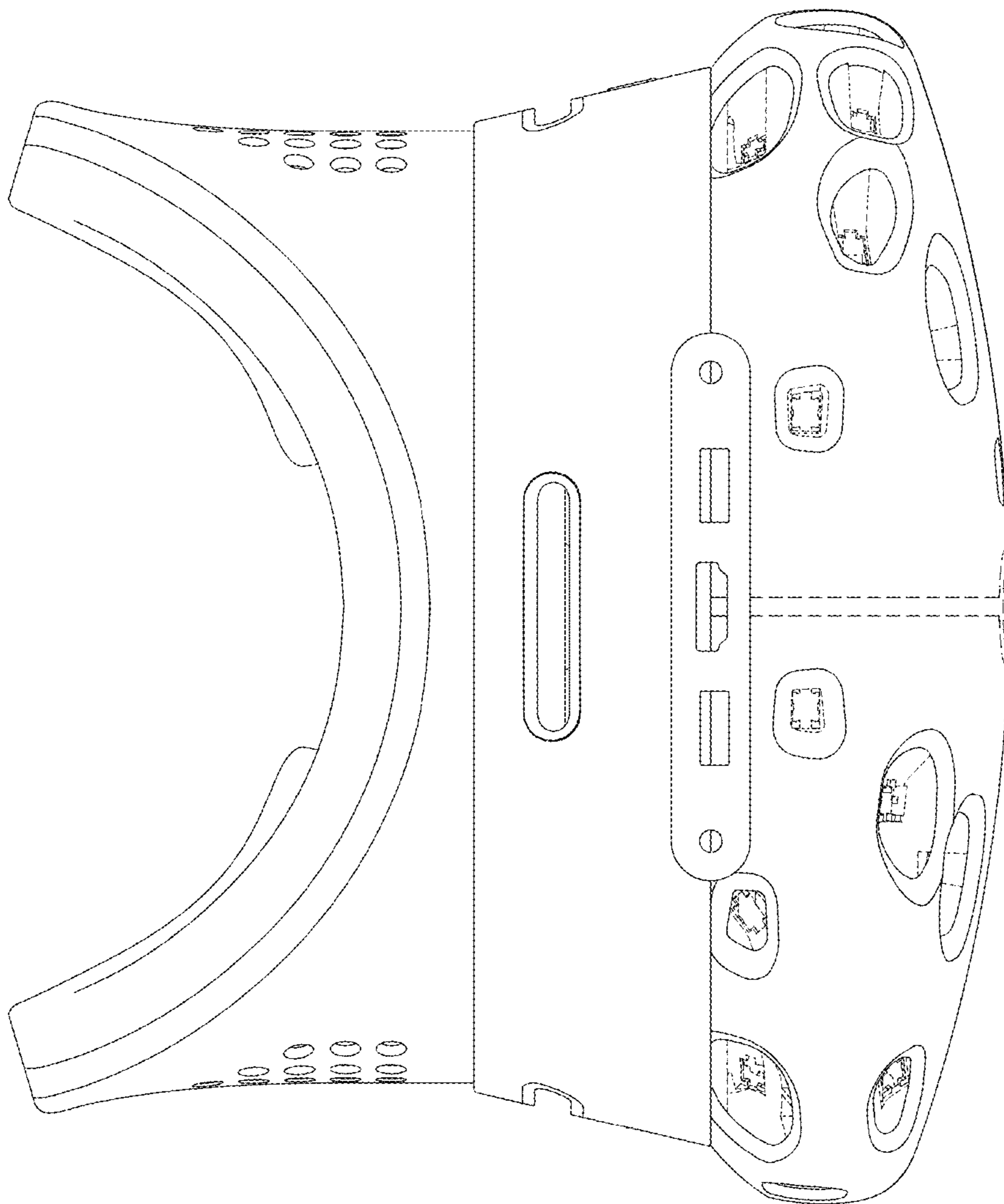

FIG. 6

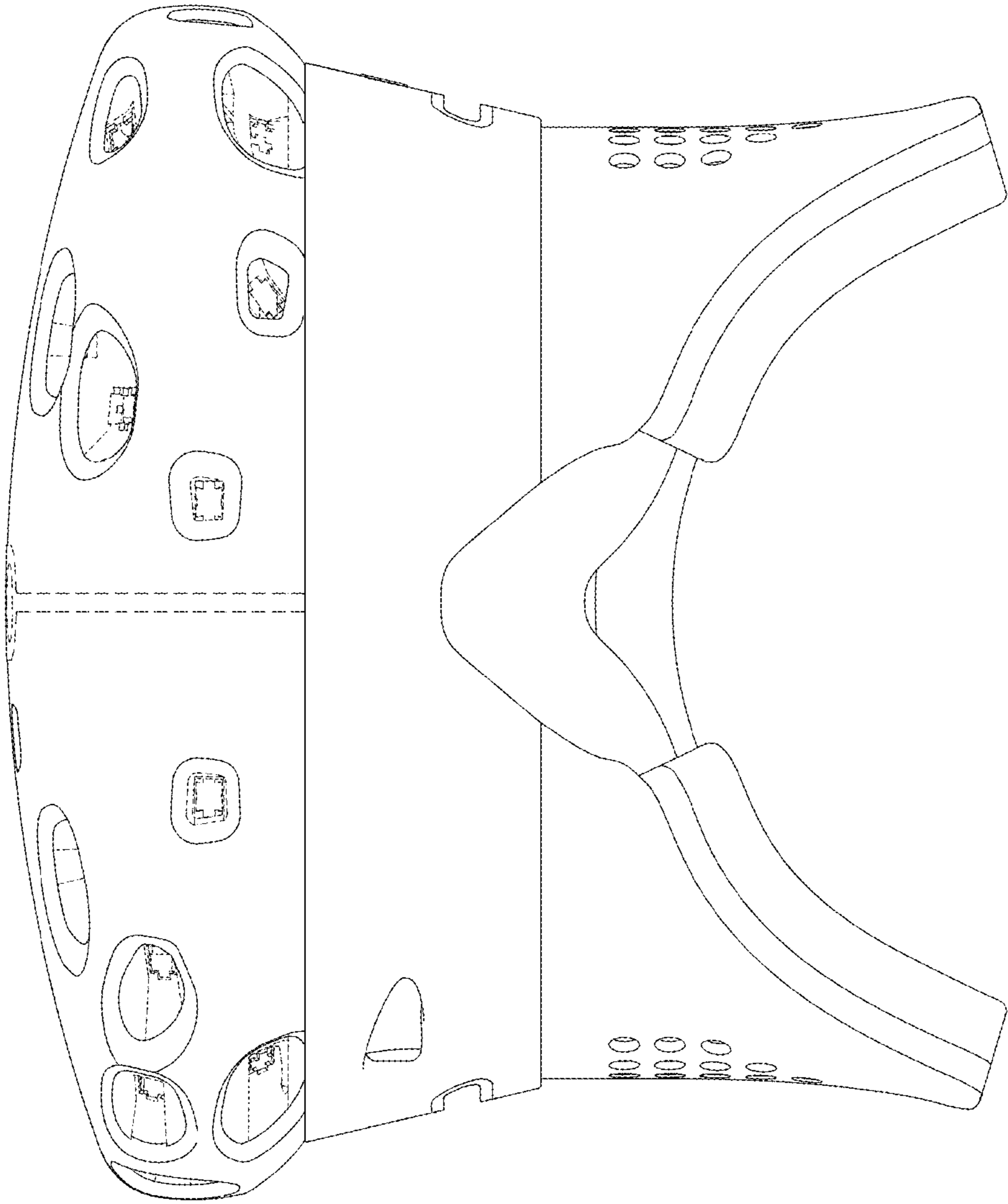

FIG. 7

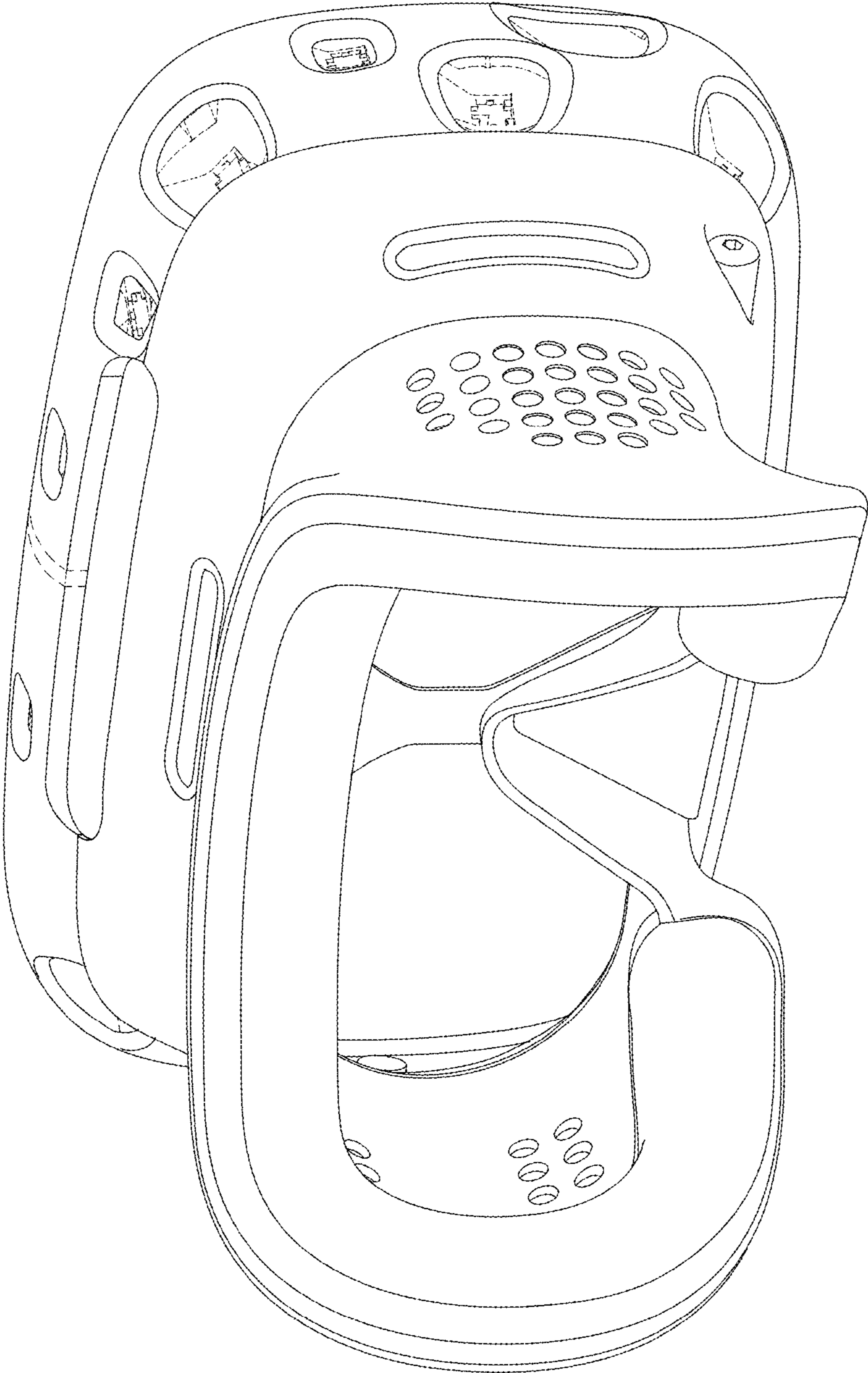

FIG. 8