

US00D775085S

(12) **United States Design Patent** (10) **Patent No.:** **US D775,085 S**
Hachisuka et al. (45) **Date of Patent:** **** Dec. 27, 2016**

(54) **GASKET FOR CARBON FIBER COMPOSITE CABLE**

(71) Applicant: **TOKYO ROPE MFG. CO. LTD,**
Tokyo (JP)

(72) Inventors: **Shunji Hachisuka**, Kasumigaura (JP);
Hiroshi Kimura, Noda (JP); **Daisuke Manabe**, Kasumigaura (JP); **Yoshihiro Tamura**, Kashiwa (JP)

(73) Assignee: **Tokyo Rope Mfg. Co.,** Tokyo (JP)

(**) Term: **14 Years**

(21) Appl. No.: **29/504,013**

(22) Filed: **Oct. 1, 2014**

(30) **Foreign Application Priority Data**

May 8, 2014 (JP) 2014-009840
May 8, 2014 (JP) 2014-009841
May 8, 2014 (JP) 2014-009842
May 8, 2014 (JP) 2014-009843
May 8, 2014 (JP) 2014-009844
May 8, 2014 (JP) 2014-009845

(51) **LOC (10) Cl.** **13-03**

(52) **U.S. Cl.**
USPC **D13/153**

(58) **Field of Classification Search**
USPC D13/153, 154, 131, 157, 156, 184, 155;
D8/356, 376; D3/10; D24/232; D9/711;
D15/199, 135; 57/241, 220
CPC D07B 1/0686; D07B 1/02
See application file for complete search history.

(56) **References Cited**

U.S. PATENT DOCUMENTS

D344,063 S * 2/1994 Letarte D13/131
D374,174 S * 10/1996 McClellan D13/154
D376,786 S * 12/1996 Binzel, Jr. D13/153
D381,008 S * 7/1997 Parsons D13/153

D385,476 S * 10/1997 Hill D8/356
D404,363 S * 1/1999 Pyle D13/154
D408,365 S * 4/1999 Sanders D13/153
D408,621 S * 4/1999 Kuo D3/10
D451,003 S * 11/2001 Proell-Immekus D8/376
D460,740 S * 7/2002 Montena D13/154
D460,947 S * 7/2002 Montena D13/154
D460,948 S * 7/2002 Montena D13/154
D463,777 S * 10/2002 Mellgren D13/157
D464,875 S * 10/2002 Koppang D9/711
D472,220 S * 3/2003 Mellgren D13/157
D498,731 S * 11/2004 Haerberle D13/156
D512,025 S * 11/2005 Frederick D13/153
D519,931 S * 5/2006 Van Haaster D13/153
D567,961 S * 4/2008 Yajima D24/232
D573,101 S * 7/2008 Ng D13/153
D575,632 S * 8/2008 Morelock D8/356
D582,454 S * 12/2008 Davies D15/199
D582,455 S * 12/2008 Davies D15/199
D582,456 S * 12/2008 Davies D15/199
D587,101 S * 2/2009 Morgan D8/356
D597,032 S * 7/2009 Yamamoto D13/153
D598,275 S * 8/2009 Rowell D8/356
D599,196 S * 9/2009 Ruffin D8/356
D620,898 S * 8/2010 Wang D13/184
D628,461 S * 12/2010 Stein, Jr. D8/356
D634,340 S * 3/2011 Luotoharju D15/135
D634,342 S * 3/2011 Luotoharju D15/135
D645,022 S * 9/2011 Lee D13/154
D653,100 S * 1/2012 Chen D8/356
D663,699 S * 7/2012 Nakamura D13/156
8,250,845 B2 * 8/2012 Kimura D07B 1/02
57/241
D680,083 S * 4/2013 Olson D13/156
D680,966 S * 4/2013 Gross D13/155
D680,967 S * 4/2013 Gross D13/155
D680,969 S * 4/2013 Gross D13/155
D704,144 S * 5/2014 Tangalakis D13/153
D747,691 S * 1/2016 Disantis D13/153
2013/0318937 A1 * 12/2013 Takeuchi D07B 1/0686
57/220

* cited by examiner

Primary Examiner — Rhea Shields

(74) *Attorney, Agent, or Firm* — Eaton & Van Winkle
LLP; Charles E. Miller

(57) **CLAIM**

The ornamental design for a gasket for carbon fiber composite cable, as shown and described.

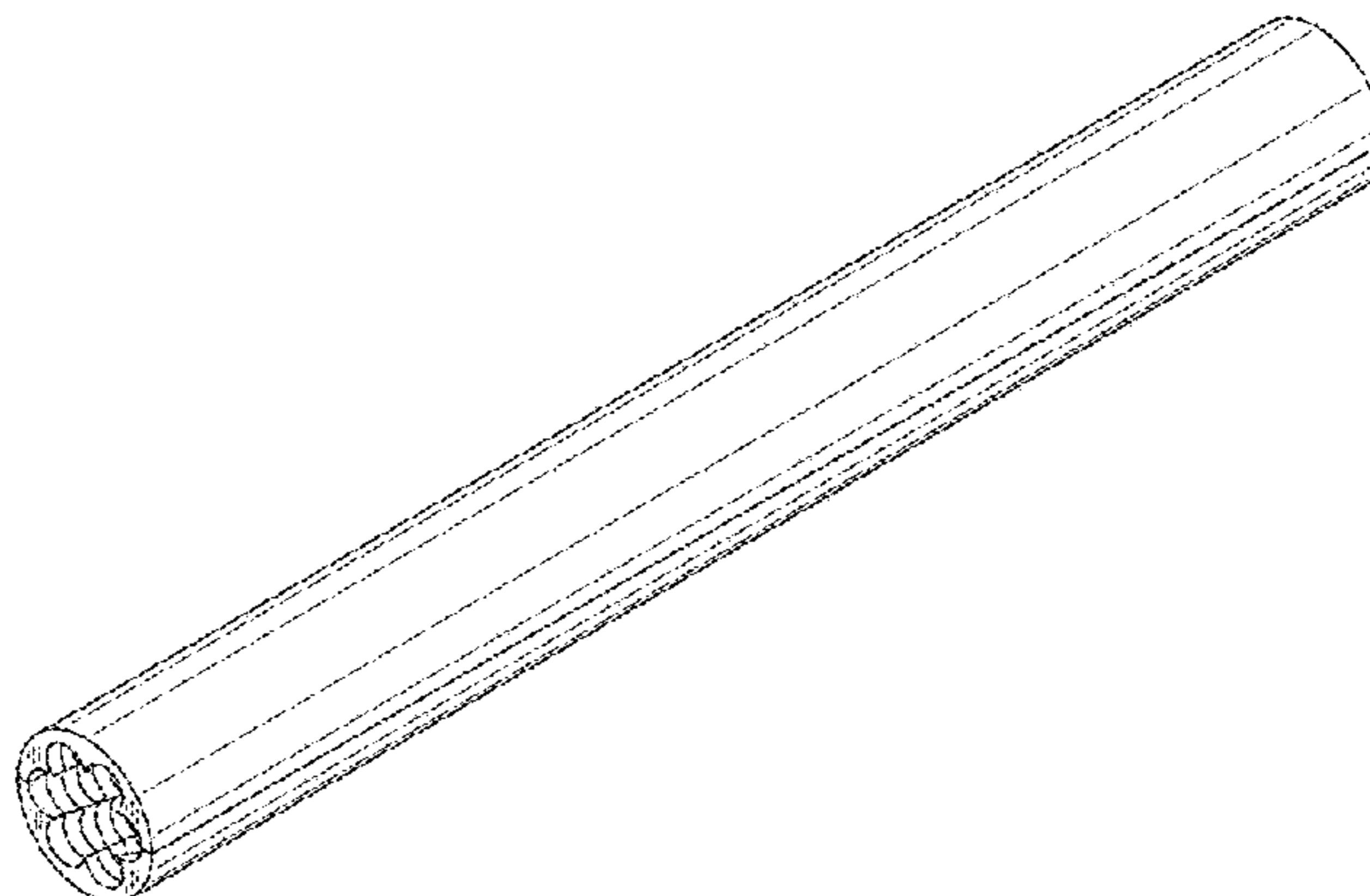

DESCRIPTION

FIG. 1 is a front, top and left side perspective view of a gasket for carbon fiber composite cable, showing our new design;

FIG. 2 is a front view thereof;

FIG. 3 is a rear view thereof;

FIG. 4 is a left side view thereof;

FIG. 5 is a right side view thereof;

FIG. 6 is a top view thereof;

FIG. 7 is a bottom view thereof;

FIG. 8 is a front view of the half-body thereof;

FIG. 9 is a rear view of the half-body thereof;

FIG. 10 is a left side view of the half-body thereof;

FIG. 11 is a right side view of the half-body thereof;

FIG. 12 is a top view of the half-body thereof;

FIG. 13 is a bottom view of the half-body thereof;

FIG. 14 is a perspective view of the gasket for carbon fiber composite cable shown in an environment.

FIG. 15 is an exploded perspective view of the gasket for carbon fiber composite cable shown in an environment.

FIG. 16 is a front, top and left side perspective view of a second embodiment of a gasket for carbon fiber composite cable, showing our new design;

FIG. 17 is a front view thereof;

FIG. 18 is a rear view thereof;

FIG. 19 is a left side view thereof;

FIG. 20 is a right side view thereof;

FIG. 21 is a top view thereof;

FIG. 22 is a bottom view thereof;

FIG. 23 is a front view of one third-body thereof;

FIG. 24 is a rear view of one third-body thereof;

FIG. 25 is a left side view of one third-body thereof;

FIG. 26 is a right side view of one third-body thereof;

FIG. 27 is a top view of one third-body thereof;

FIG. 28 is a bottom view of one third-body thereof;

FIG. 29 is a perspective view of the gasket for carbon fiber composite cable shown in an environment.

FIG. 30 is an exploded perspective of the gasket for carbon fiber composite cable shown in an environment.

FIG. 31 is a front, top and left side perspective view of a third embodiment of a gasket for carbon fiber composite cable, showing our new design;

FIG. 32 is a front view thereof;

FIG. 33 is a rear view thereof;

FIG. 34 is a left side view thereof;

FIG. 35 is a right side view thereof;

FIG. 36 is a top view thereof;

FIG. 37 is a bottom view thereof;

FIG. 38 is a front view of one quarter-body thereof;

FIG. 39 is a rear view of one quarter-body thereof;

FIG. 40 is a left side view of one quarter-body thereof;

FIG. 41 is a right side view of one quarter-body thereof;

FIG. 42 is a top view of one quarter-body thereof;

FIG. 43 is a bottom view of one quarter-body thereof;

FIG. 44 is a perspective view of the gasket for carbon fiber composite cable shown in an environment.

FIG. 45 is an exploded perspective view of the gasket for carbon fiber composite cable shown in an environment.

FIG. 46 is a front, top and left side perspective view of a fourth embodiment of a gasket for carbon fiber composite cable, showing our new design;

FIG. 47 is a front view thereof;

FIG. 48 is a rear view thereof;

FIG. 49 is a left side view thereof;

FIG. 50 is a right side view thereof;

FIG. 51 is a top view thereof;

FIG. 52 is a bottom view thereof;

FIG. 53 is a front view of the half-body thereof;

FIG. 54 is a rear view of the half-body thereof;

FIG. 55 is a left side view of the half-body thereof;

FIG. 56 is a right side view of the half-body thereof;

FIG. 57 is a top view of the half-body thereof;

FIG. 58 is a bottom view of the half-body thereof;

FIG. 59 is a perspective view of the gasket for carbon fiber composite cable shown in an environment.

FIG. 60 is an exploded perspective view of the gasket for carbon fiber composite cable shown in an environment.

FIG. 61 is a front, top and left side perspective view of a fifth embodiment of a gasket for carbon fiber composite cable, showing our new design;

FIG. 62 is a front view thereof;

FIG. 63 is a rear view thereof;

FIG. 64 is a left side view thereof;

FIG. 65 is a right side view thereof;

FIG. 66 is a top view thereof;

FIG. 67 is a bottom view thereof;

FIG. 68 is a front view of one third-body thereof;

FIG. 69 is a rear view of one third-body thereof;

FIG. 70 is a left side view of one third-body thereof;

FIG. 71 is a right side view of one third-body thereof;

FIG. 72 is a top view of one third-body thereof;

FIG. 73 is a bottom view of one third-body thereof;

FIG. 74 is a perspective view of the gasket for carbon fiber composite cable shown in an environment.

FIG. 75 is an exploded perspective view of the gasket for carbon fiber composite cable shown in an environment.

FIG. 76 is a front, top and left side perspective view of a sixth embodiment of a gasket for carbon fiber composite cable, showing our new design;

FIG. 77 is a front view thereof;

FIG. 78 is a rear view thereof;

FIG. 79 is a left side view thereof;

FIG. 80 is a right side view thereof;

FIG. 81 is a top view thereof;

FIG. 82 is a bottom view thereof;

FIG. 83 is a front view of one quarter-body thereof;

FIG. 84 is a rear view of one quarter-body thereof;

FIG. 85 is a left side view of one quarter-body thereof;

FIG. 86 is a right side view of one quarter-body thereof;

FIG. 87 is a top view of one quarter-body thereof;

FIG. 88 is a bottom view of one quarter-body thereof;

FIG. 89 is a perspective view of the gasket for carbon fiber composite cable shown in an environment; and,

FIG. 90 is an exploded perspective view of the gasket for carbon fiber composite cable shown in an environment.

In FIGS. 14, 15, 29, 30, 44, 45, 59, 60, 74, 75, 89 and 90, the broken lines are for the purpose of illustrating environment only and form no part of the claimed design.

The front view shows only a part of the design, which actually extends in horizontal directions.

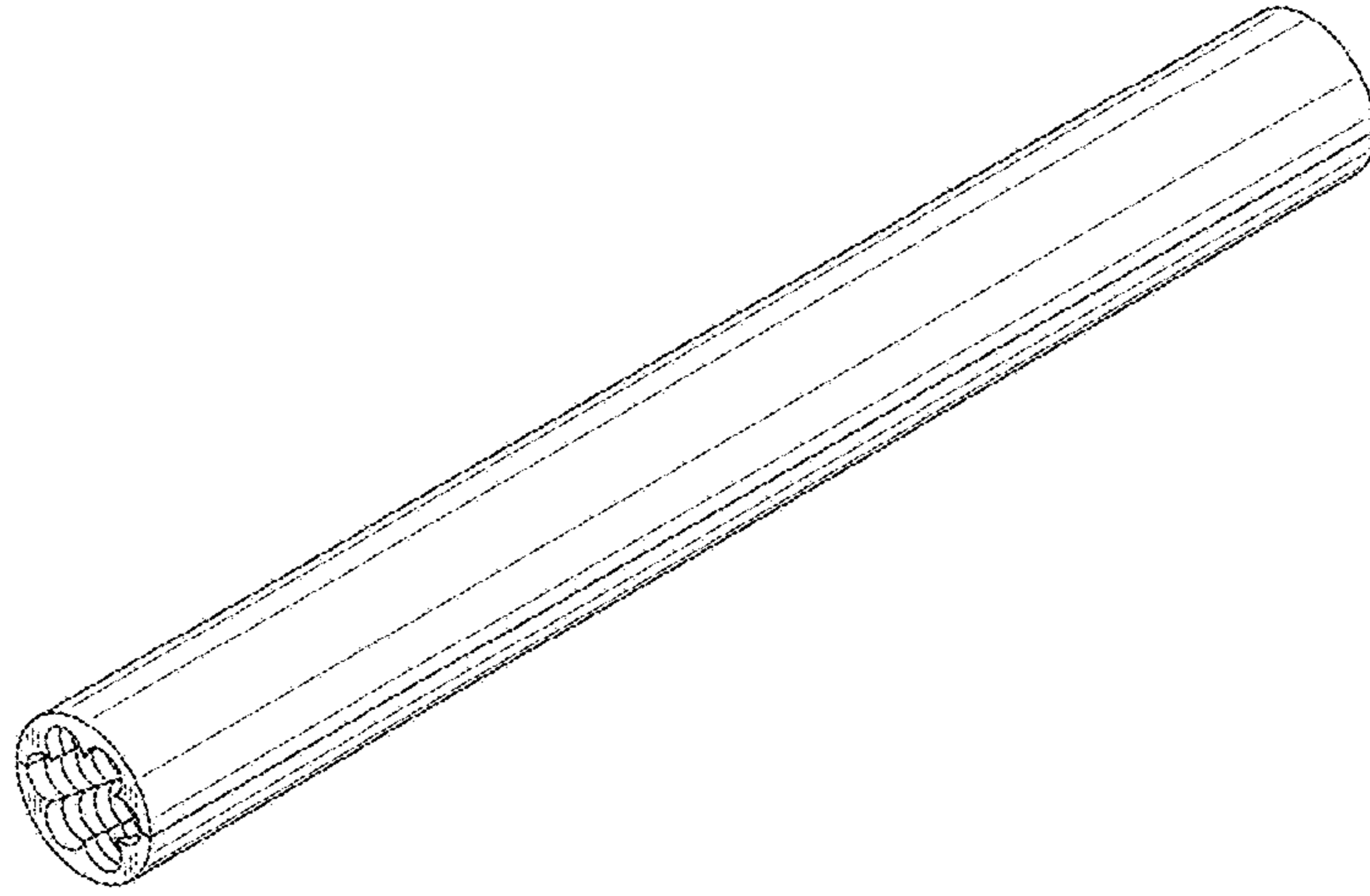

Fig. 1

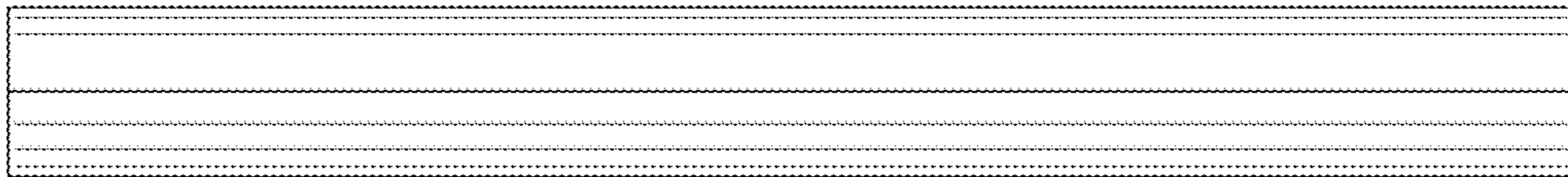

Fig. 2

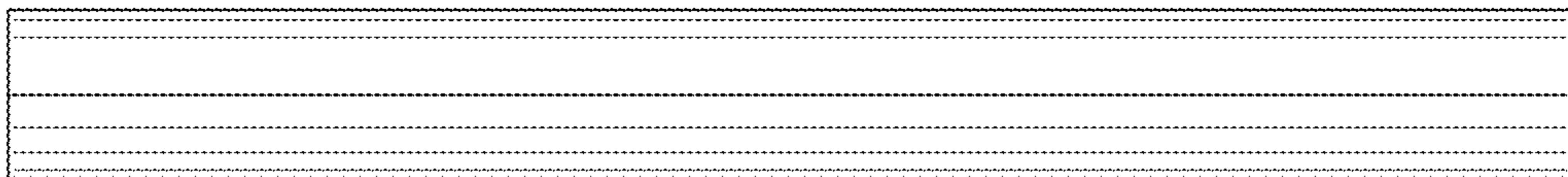

Fig. 3

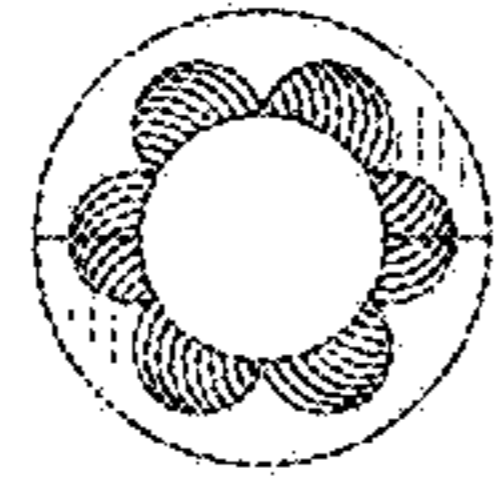

Fig. 4

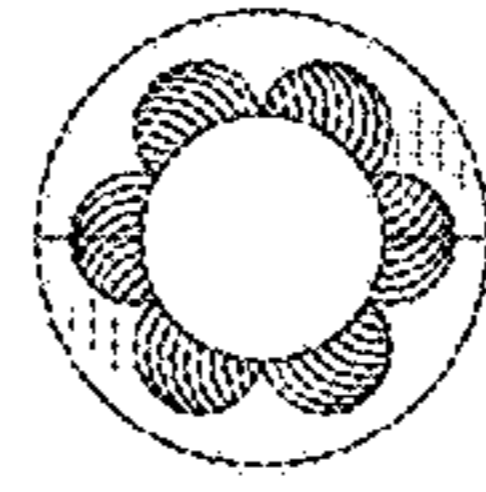

Fig. 5

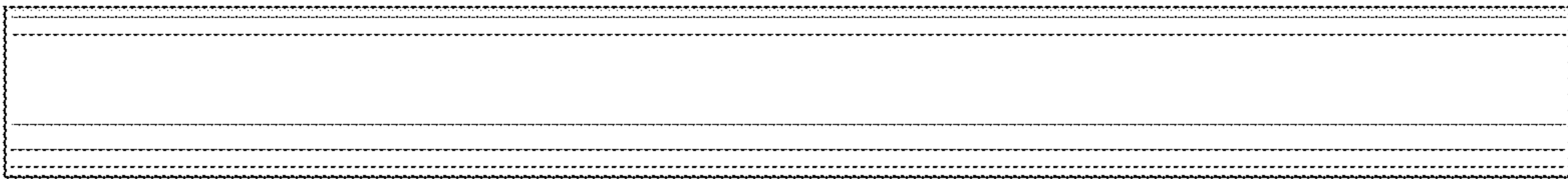

Fig. 6

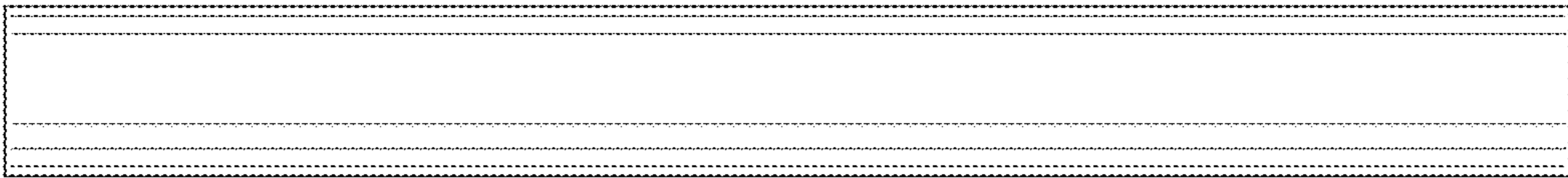

Fig. 7

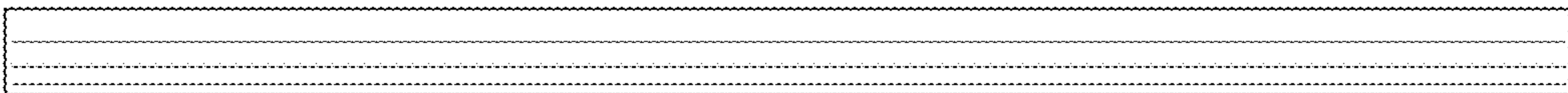

Fig. 8

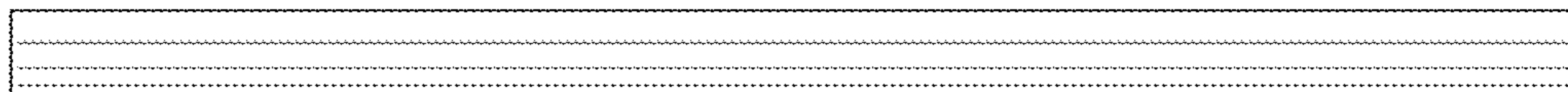

Fig. 9

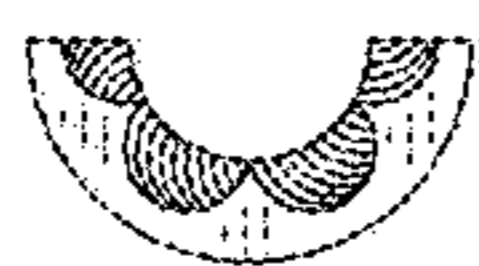

Fig. 10

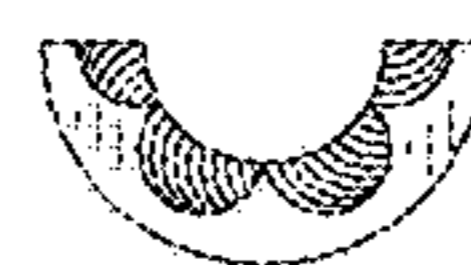

Fig. 11

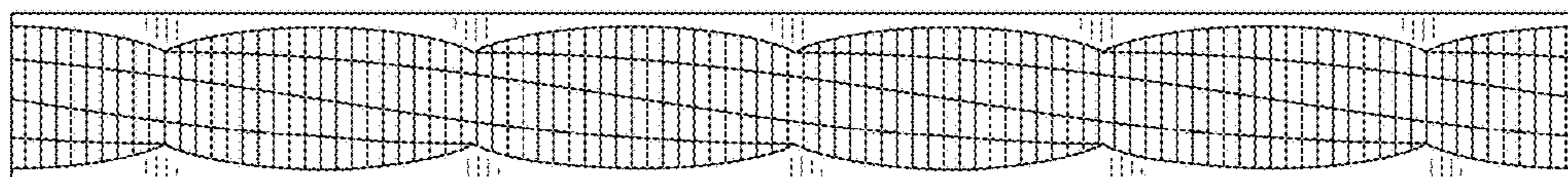

Fig. 12

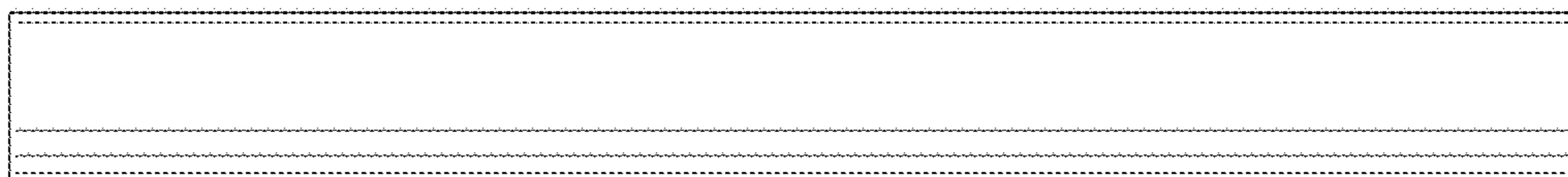

Fig. 13

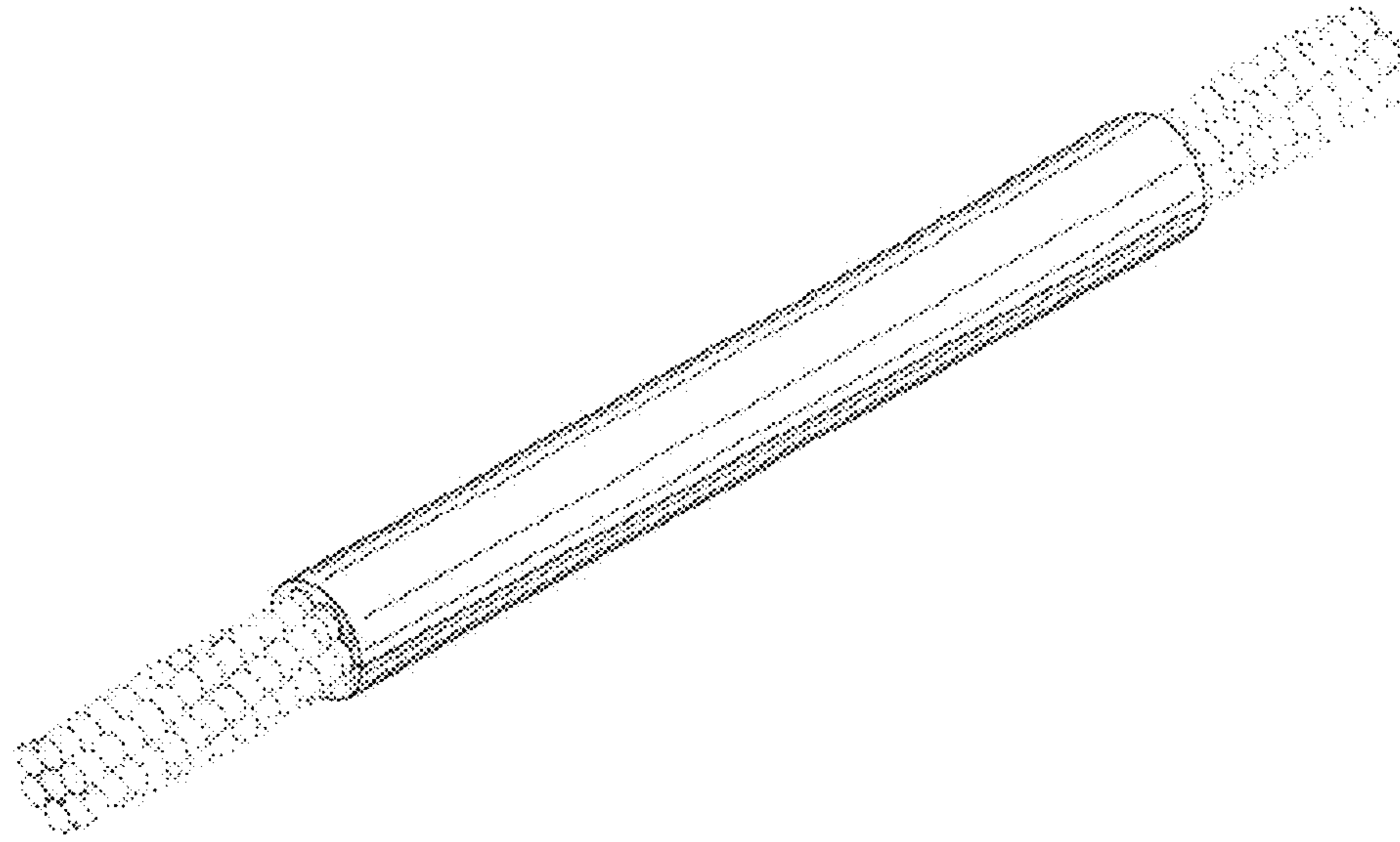

Fig. 14

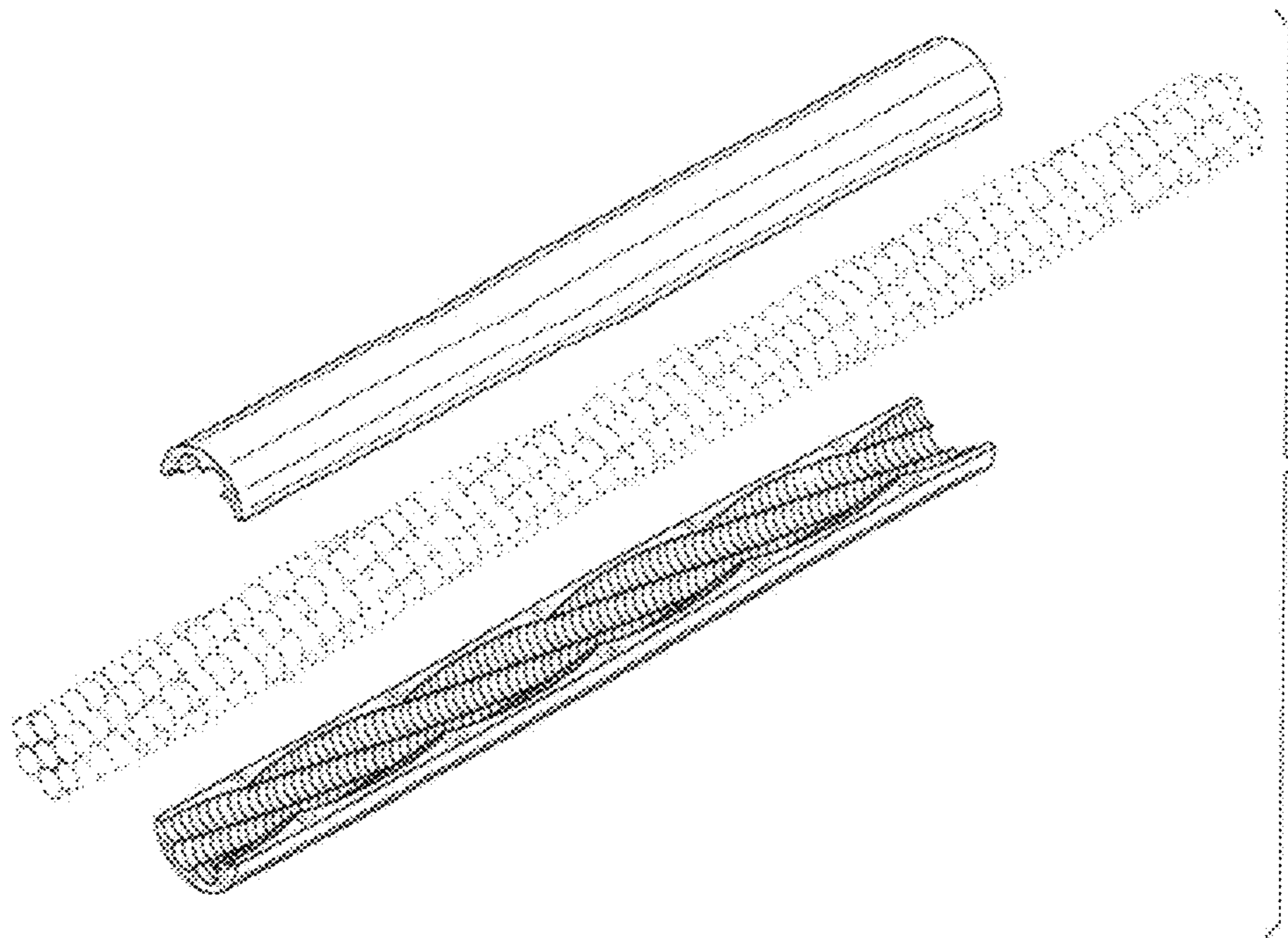

Fig. 15

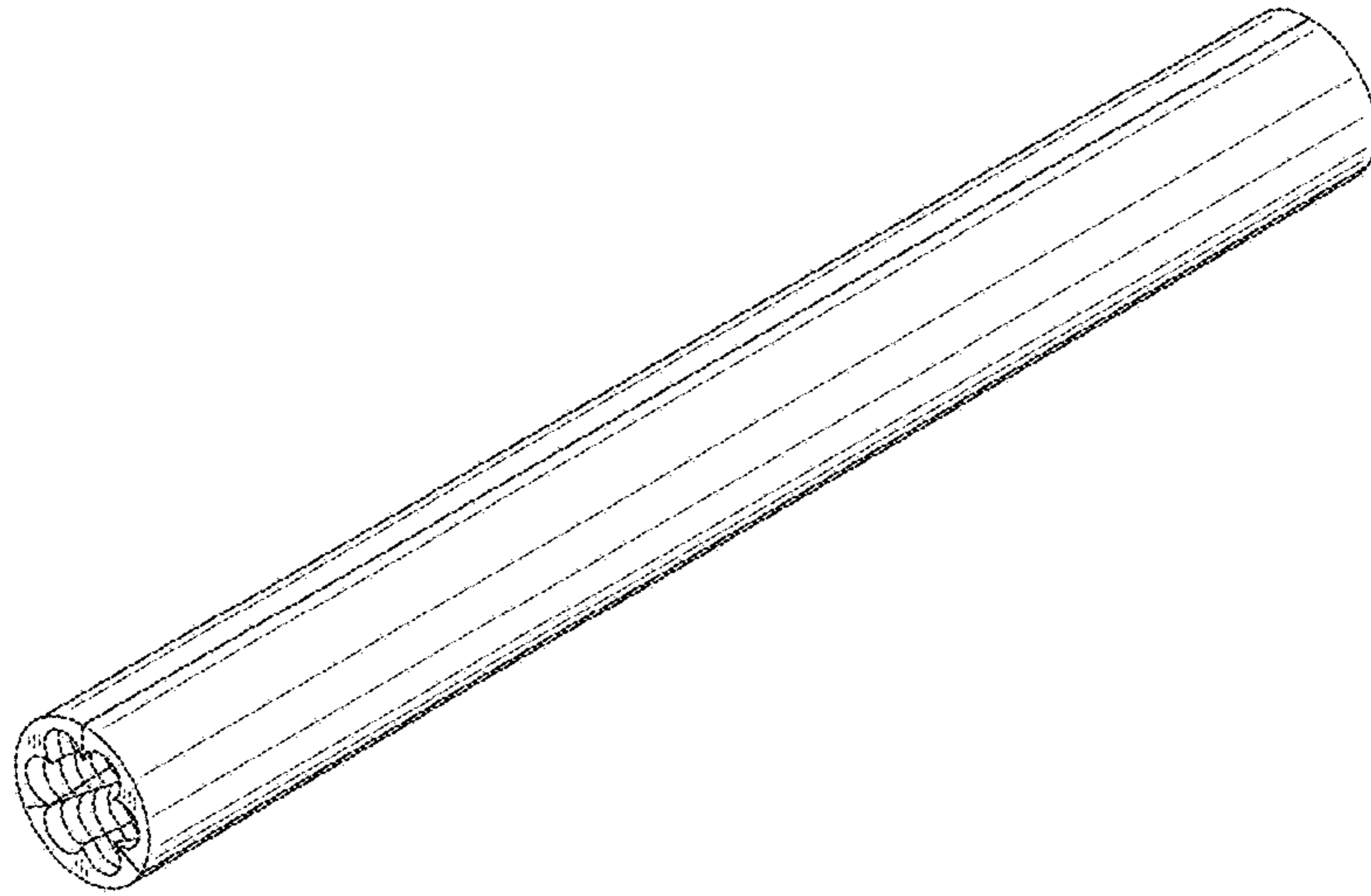

Fig. 16

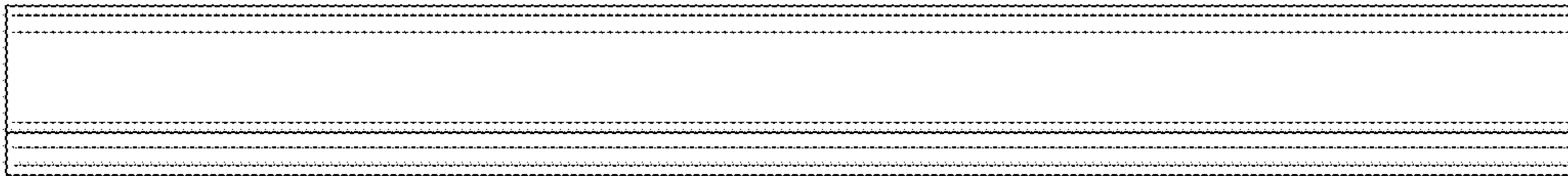

Fig. 17

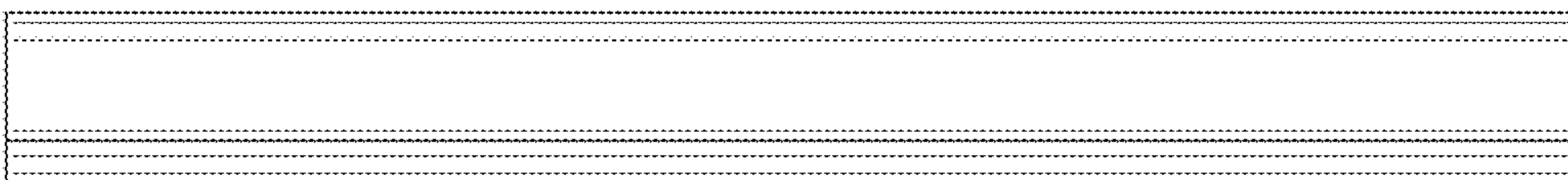

Fig. 18

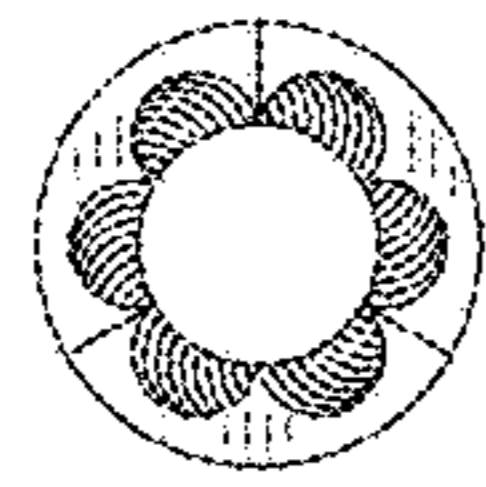

Fig. 19

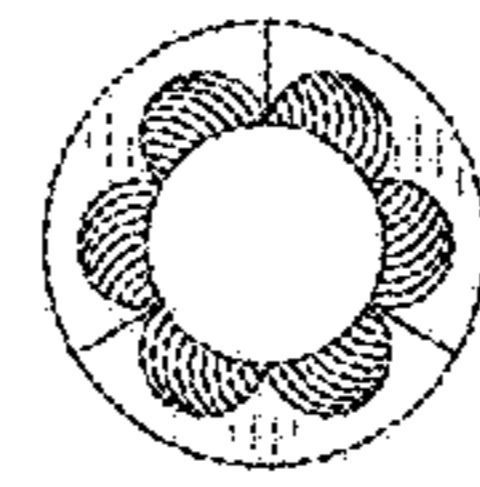

Fig. 20

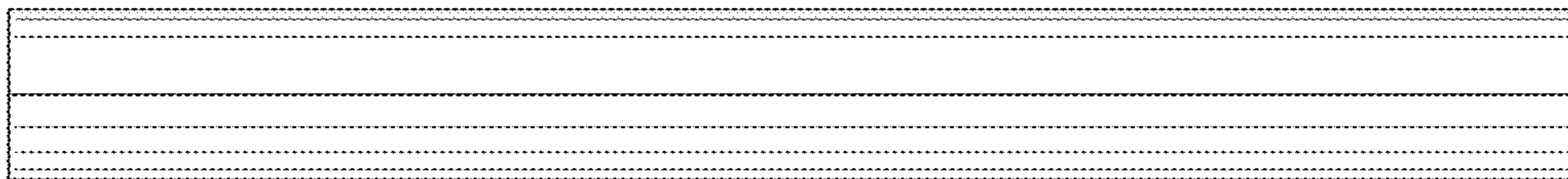

Fig. 21

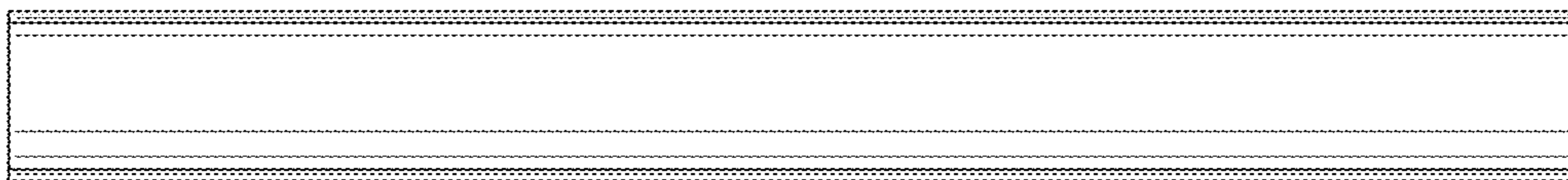

Fig. 22

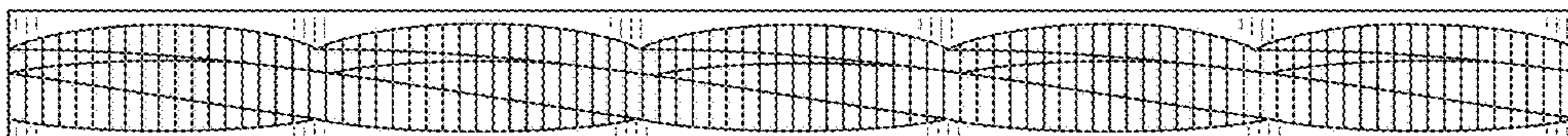

Fig. 23

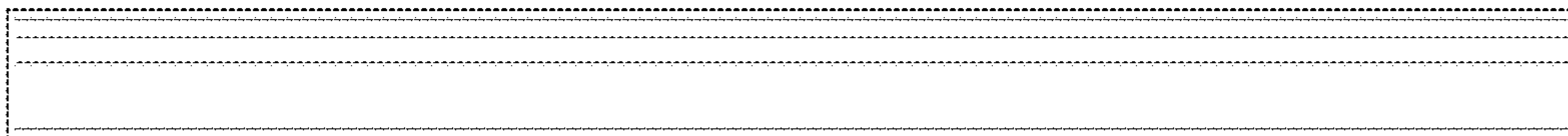

Fig. 24



Fig. 25



Fig. 26

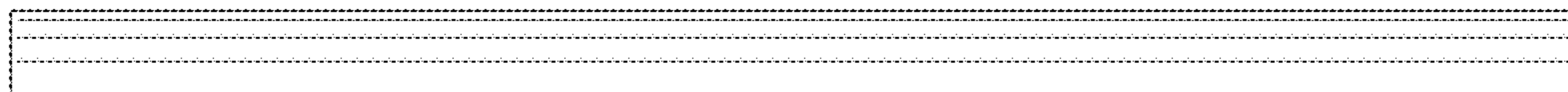

Fig. 27



Fig. 28

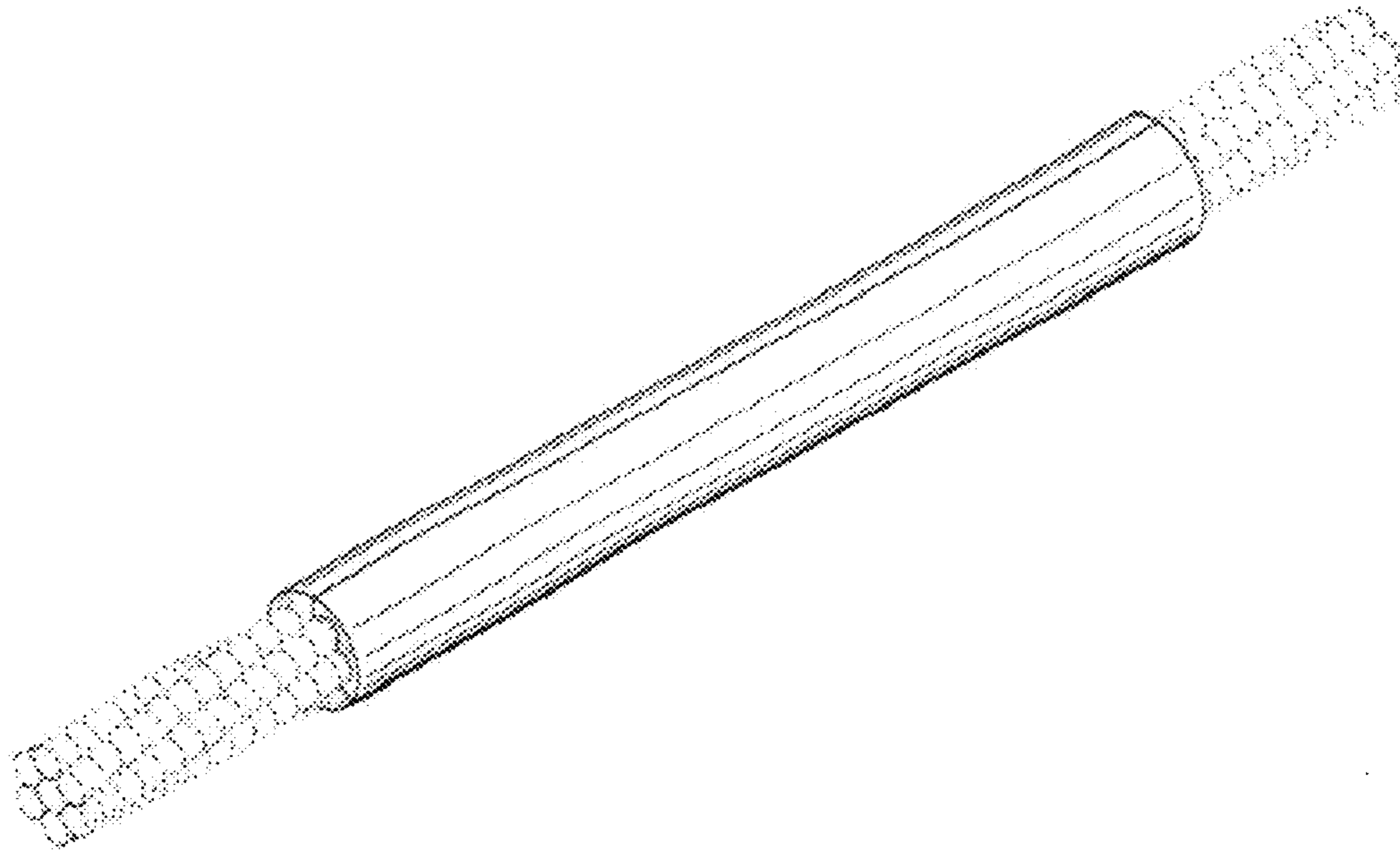

Fig. 29

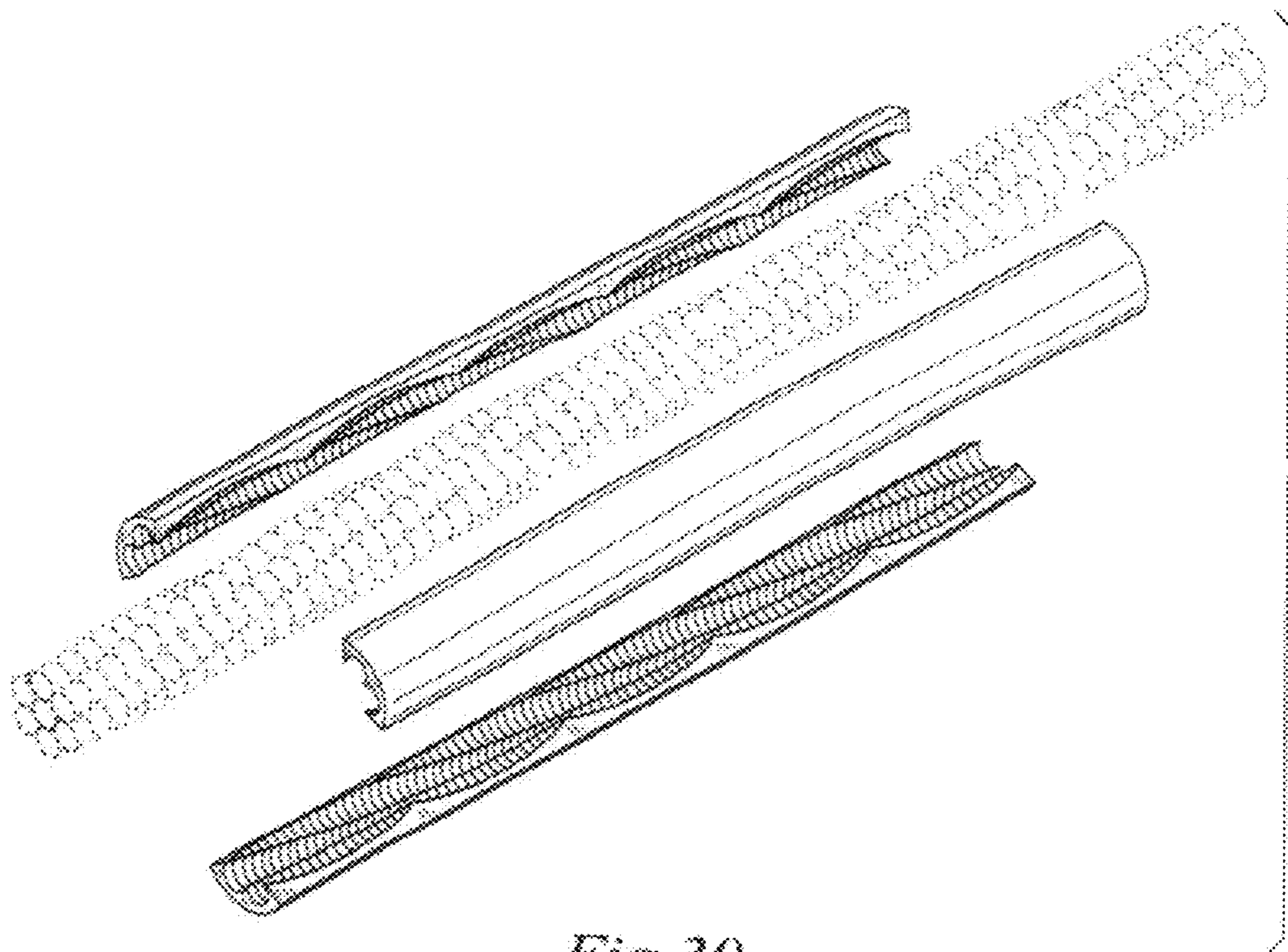

Fig. 30

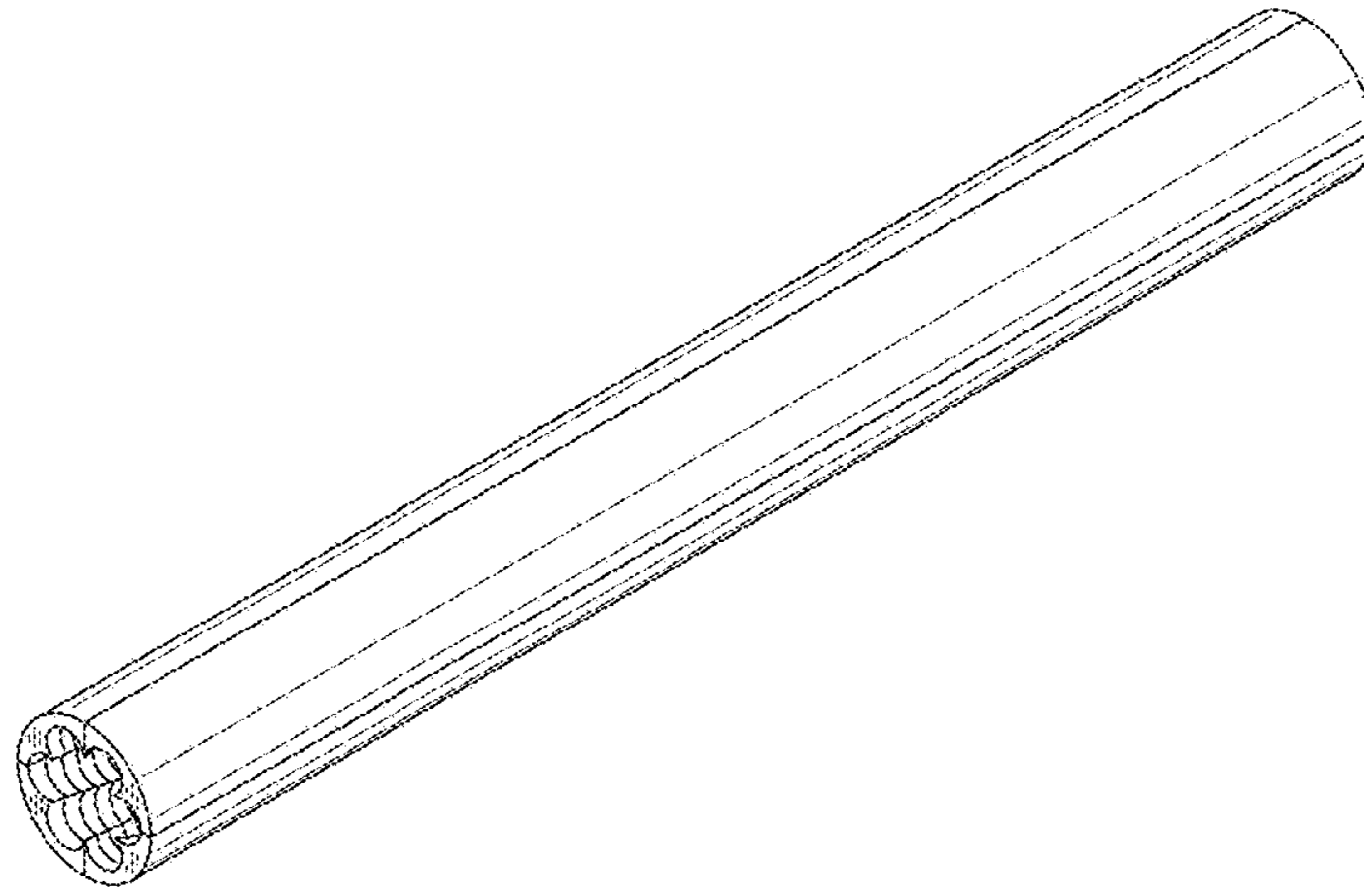

Fig.31

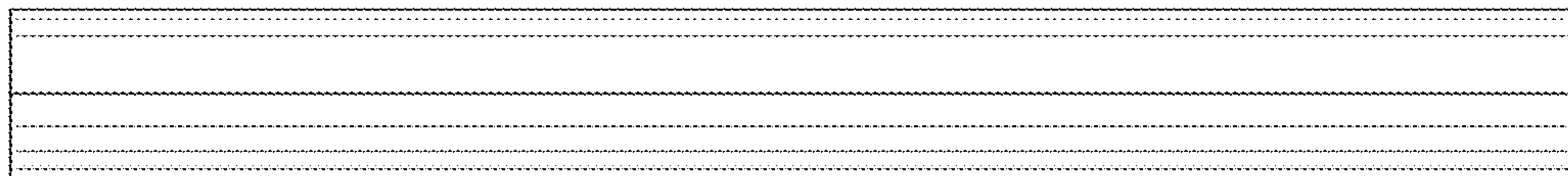

Fig.32

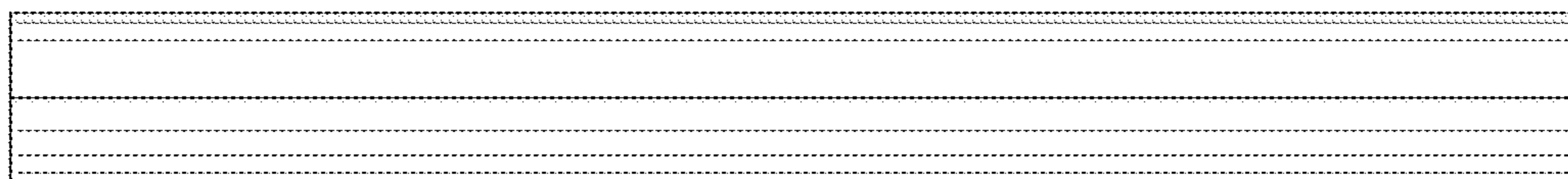

Fig.33

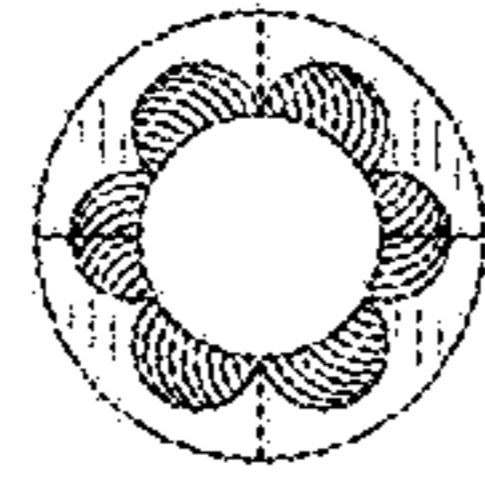

Fig.34

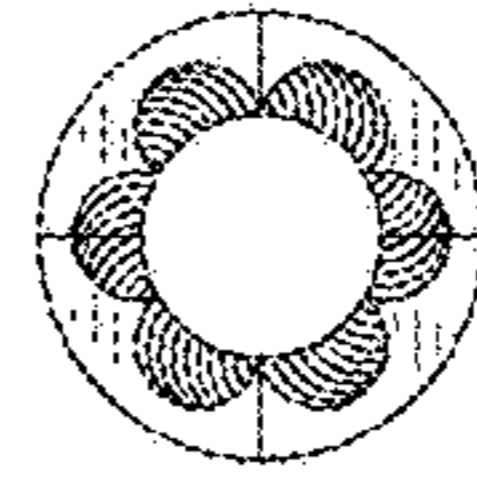

Fig.35

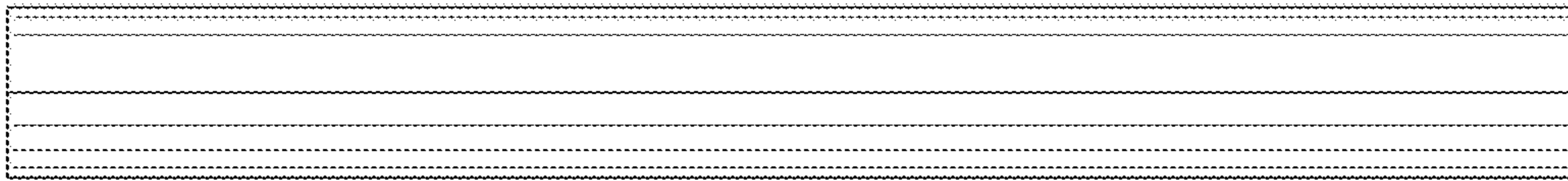

Fig.36

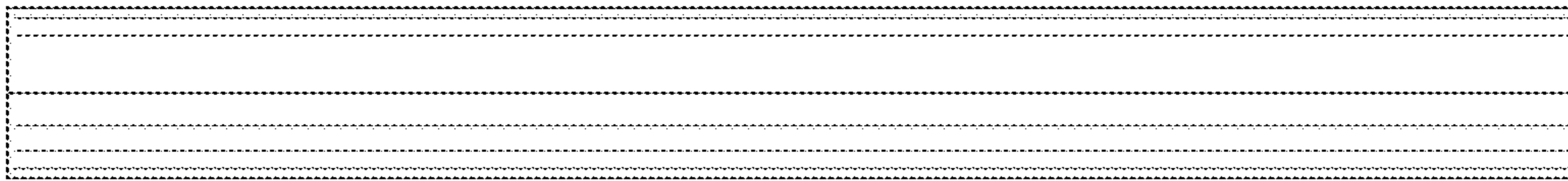

Fig.37



Fig.38

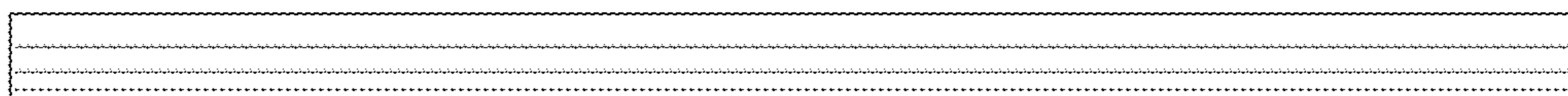

Fig. 39



Fig. 40



Fig. 41

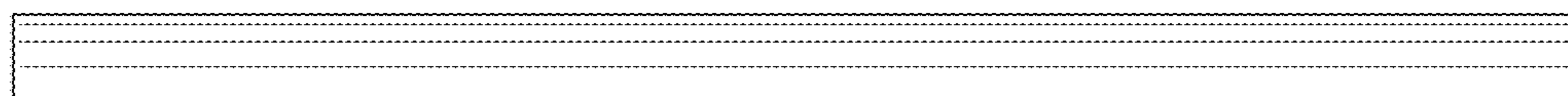

Fig. 42



Fig. 43

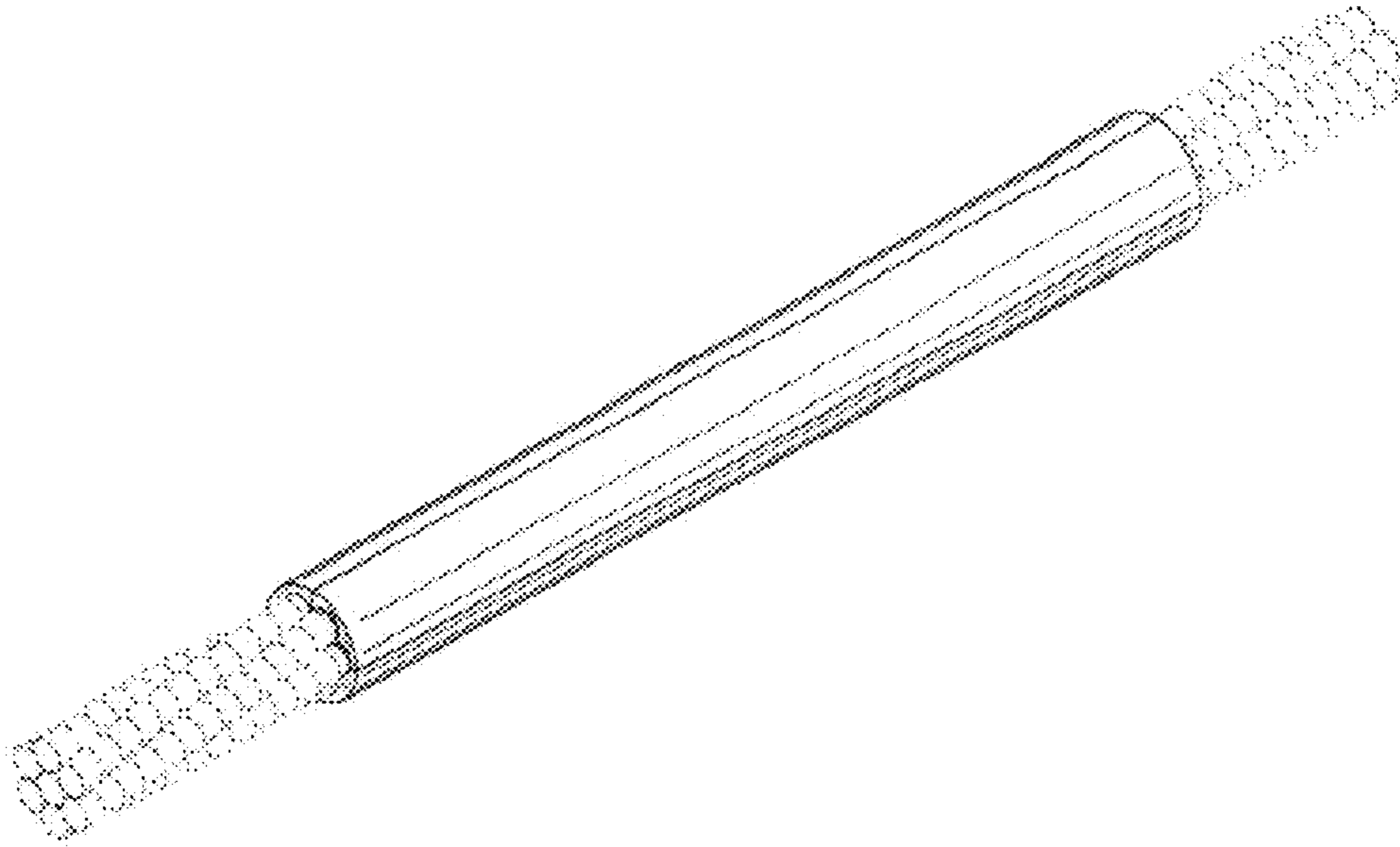

Fig. 44

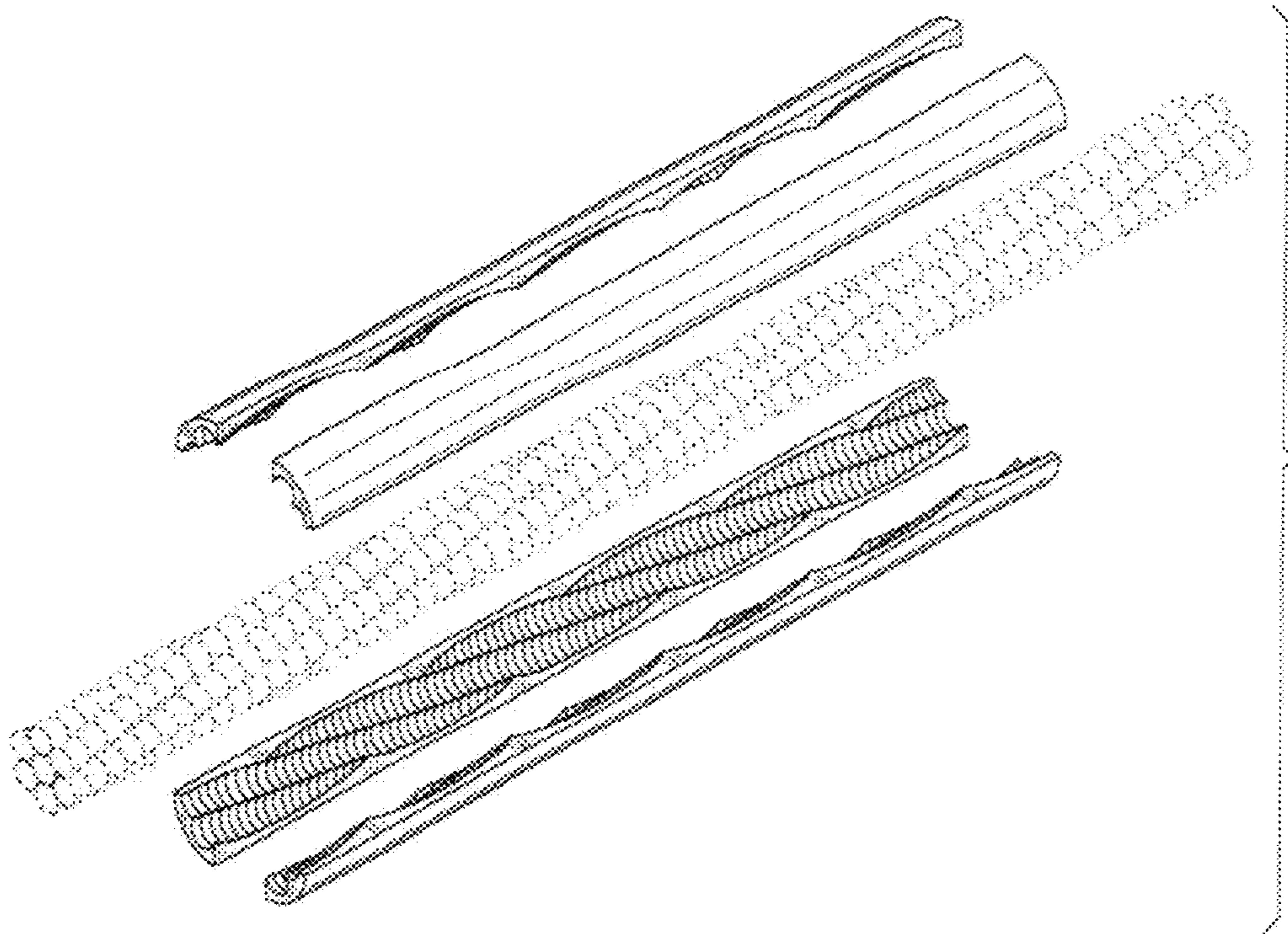

Fig. 45

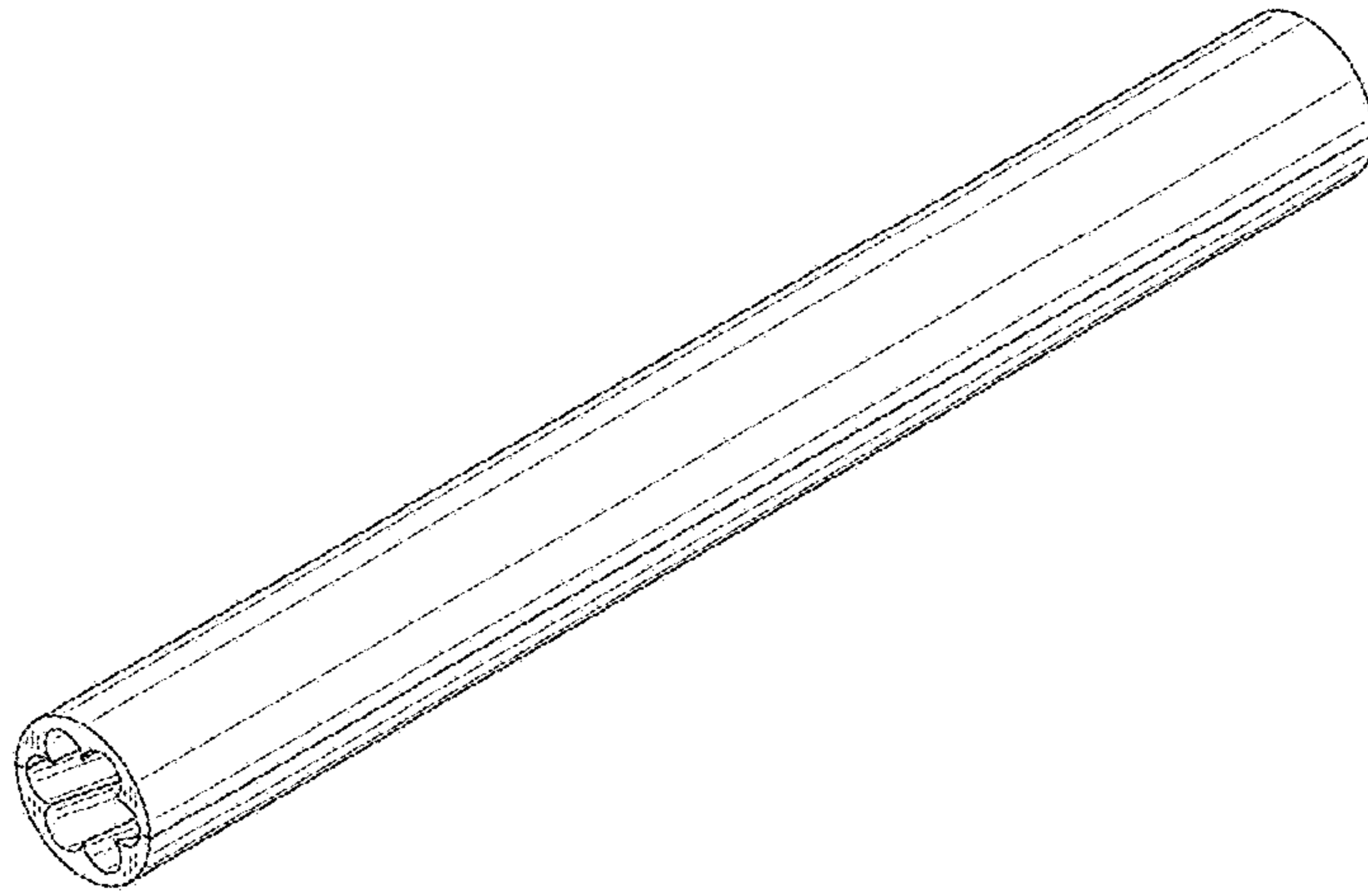

Fig. 46

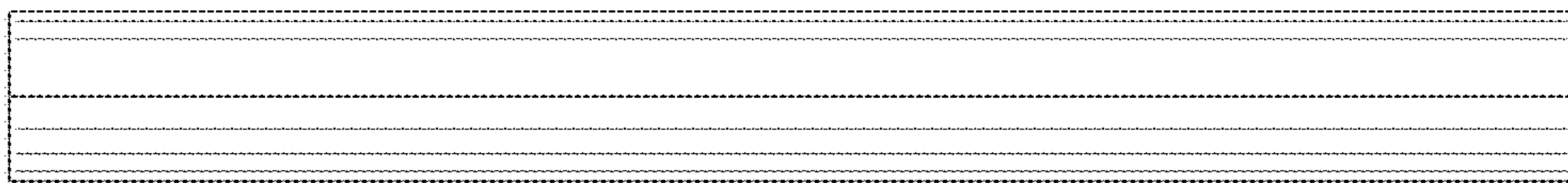

Fig. 47

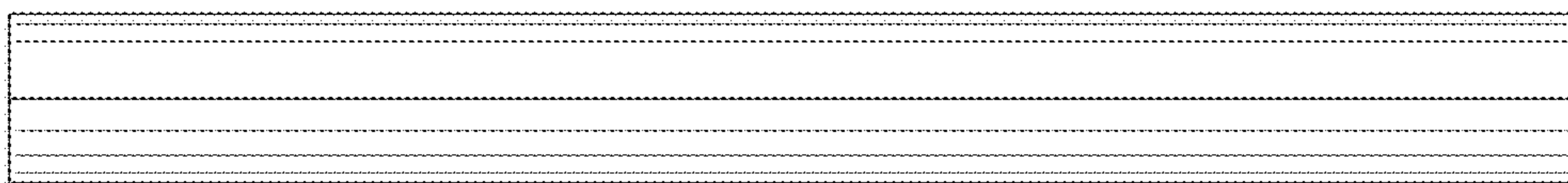

Fig. 48

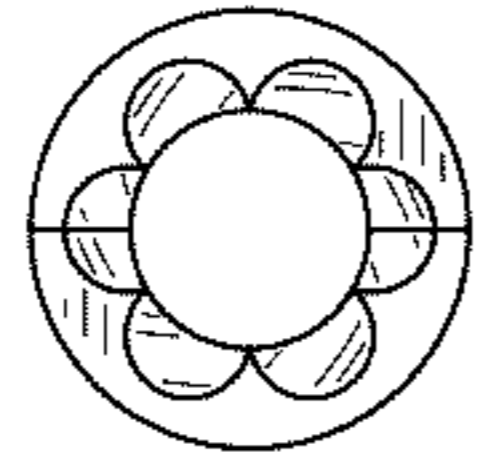

Fig. 49

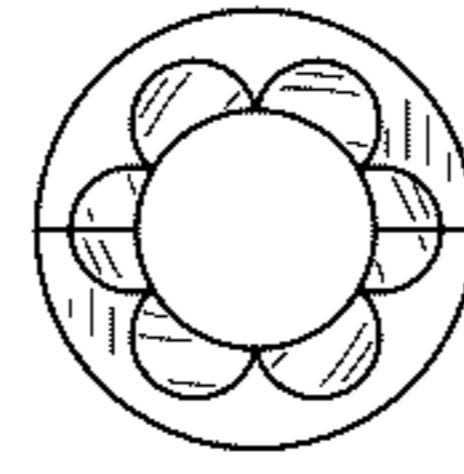

Fig. 50

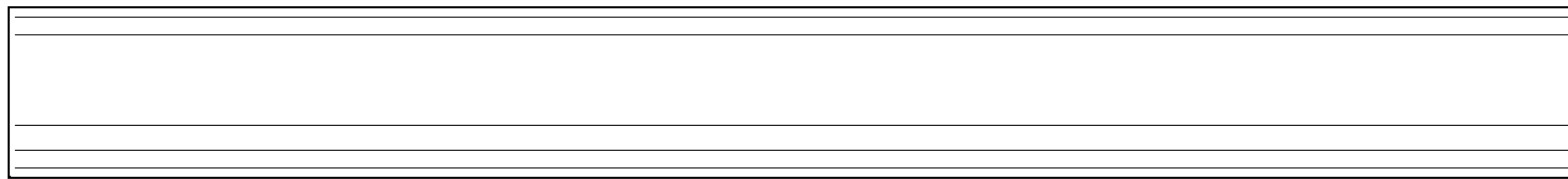

Fig. 51

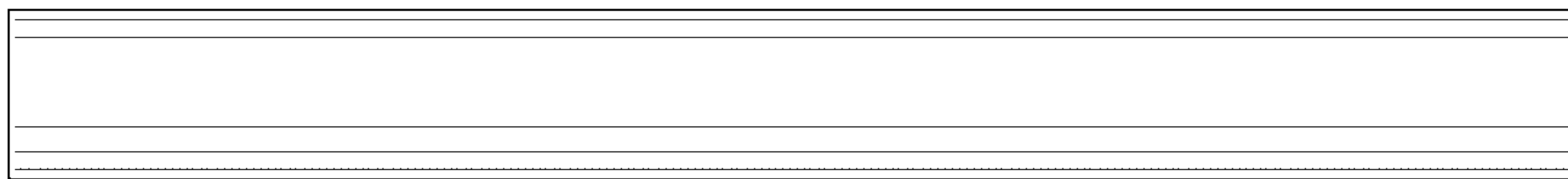

Fig. 52

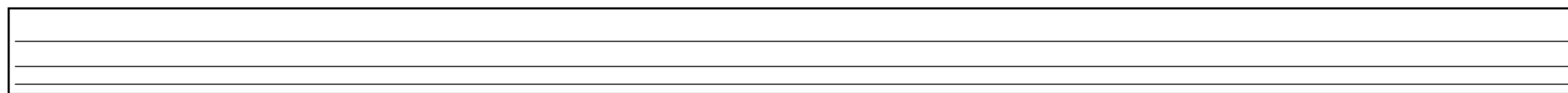

Fig. 53

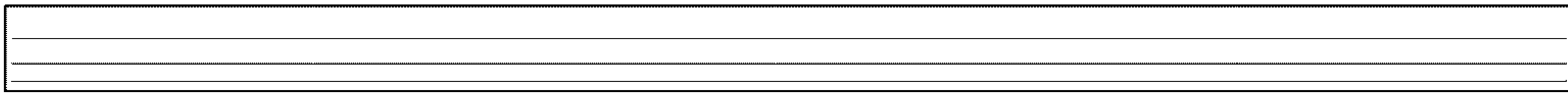

Fig. 54



Fig. 55



Fig. 56

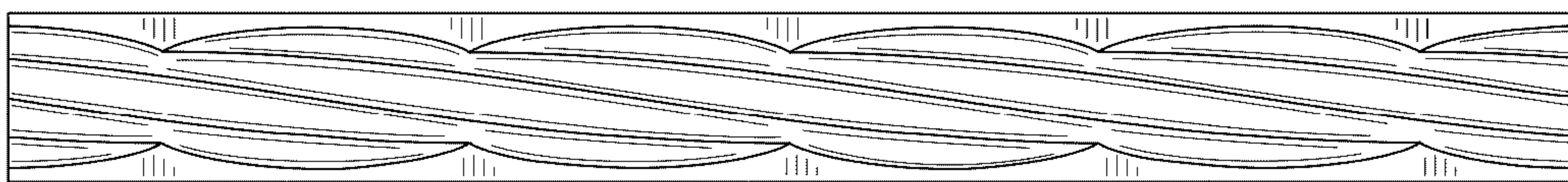

Fig. 57

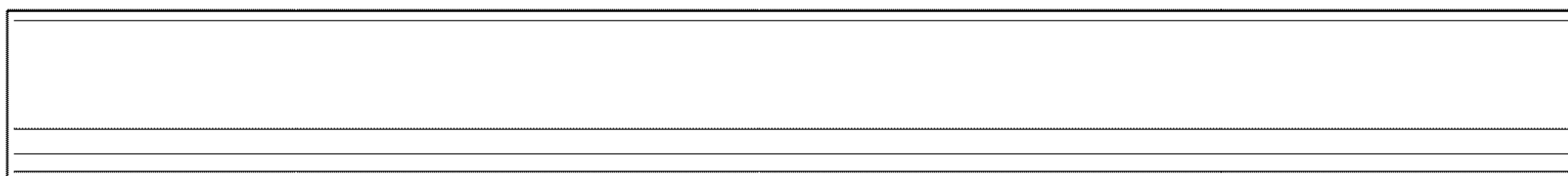

Fig. 58

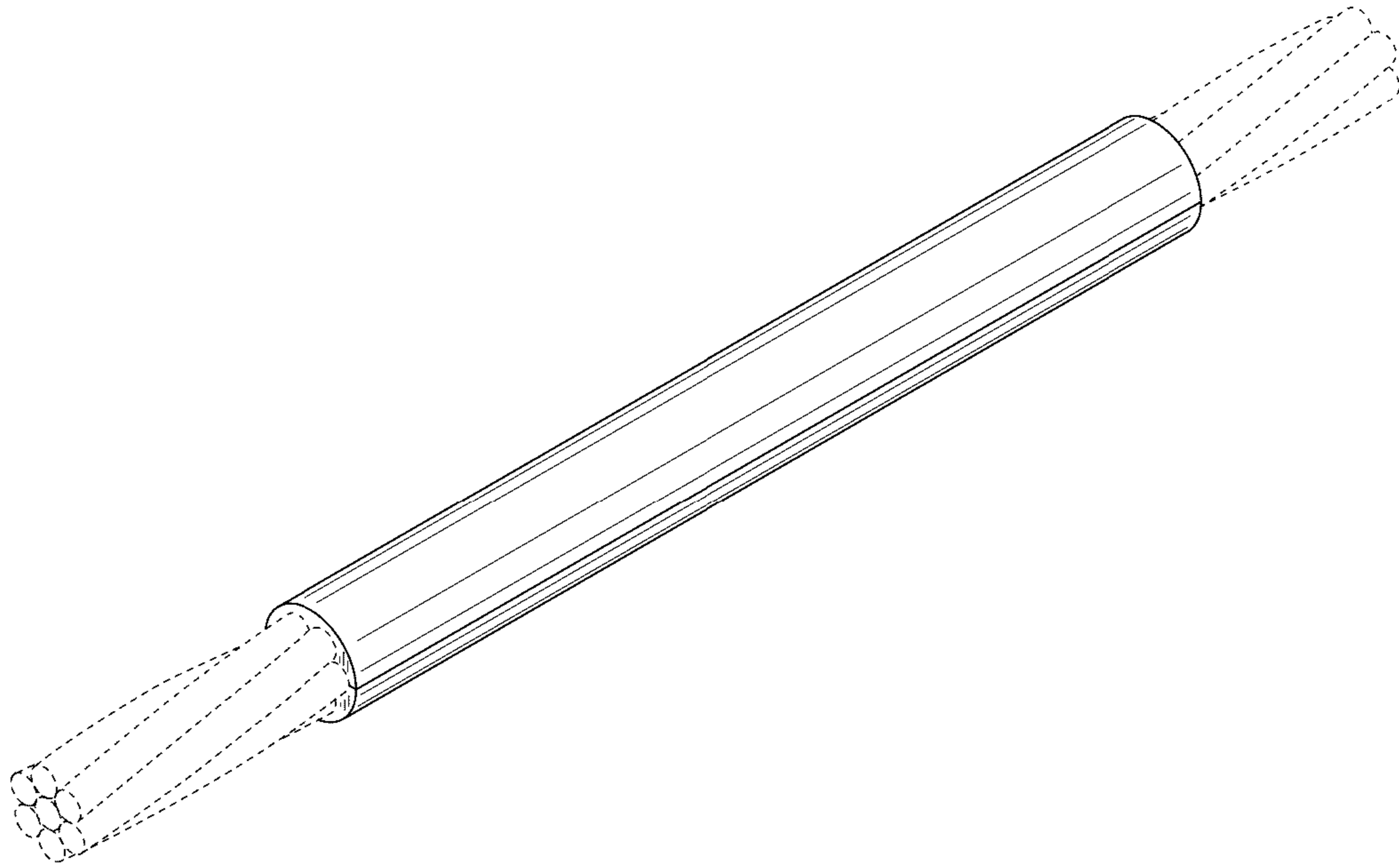

Fig. 59

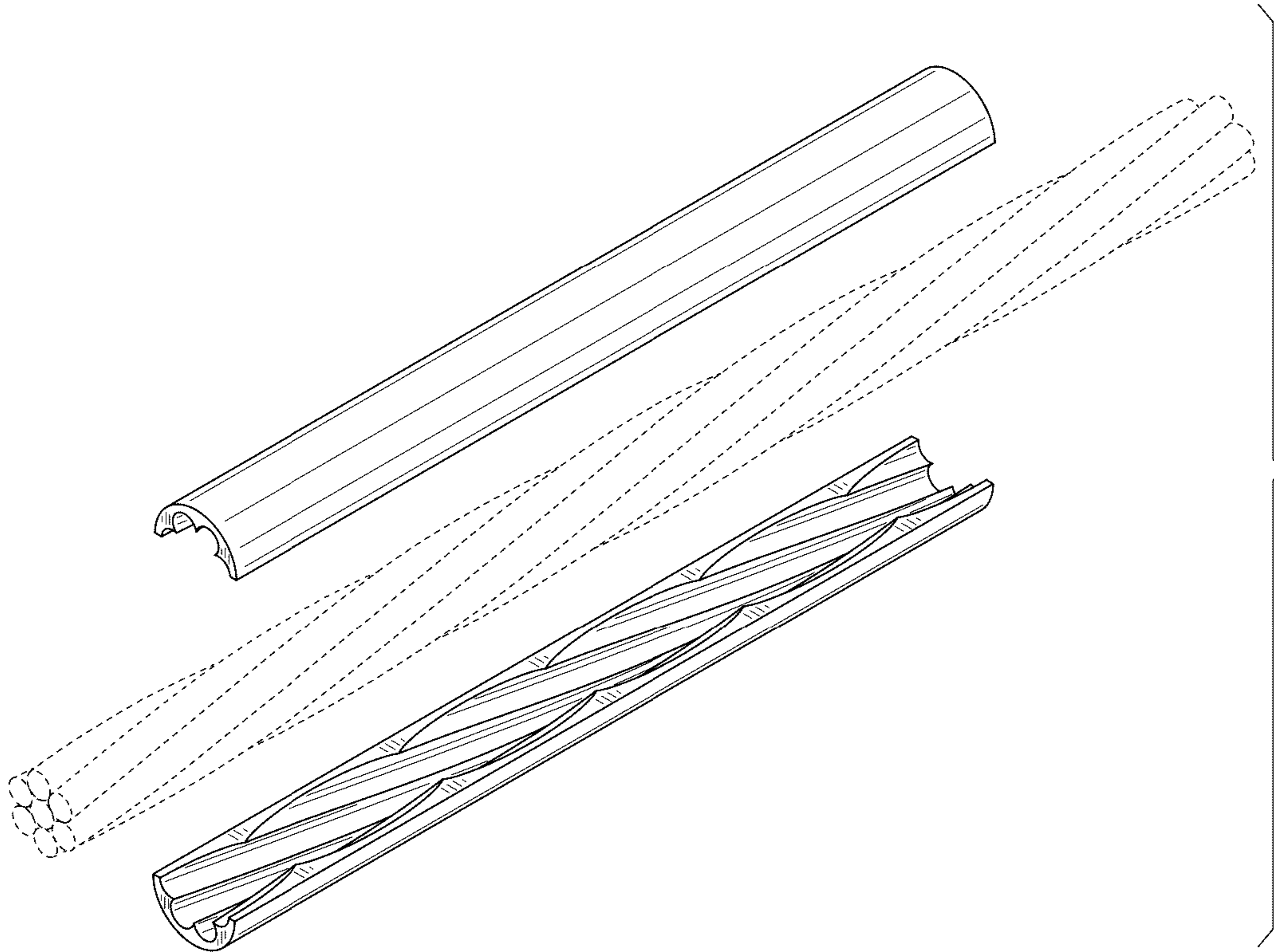

Fig. 60

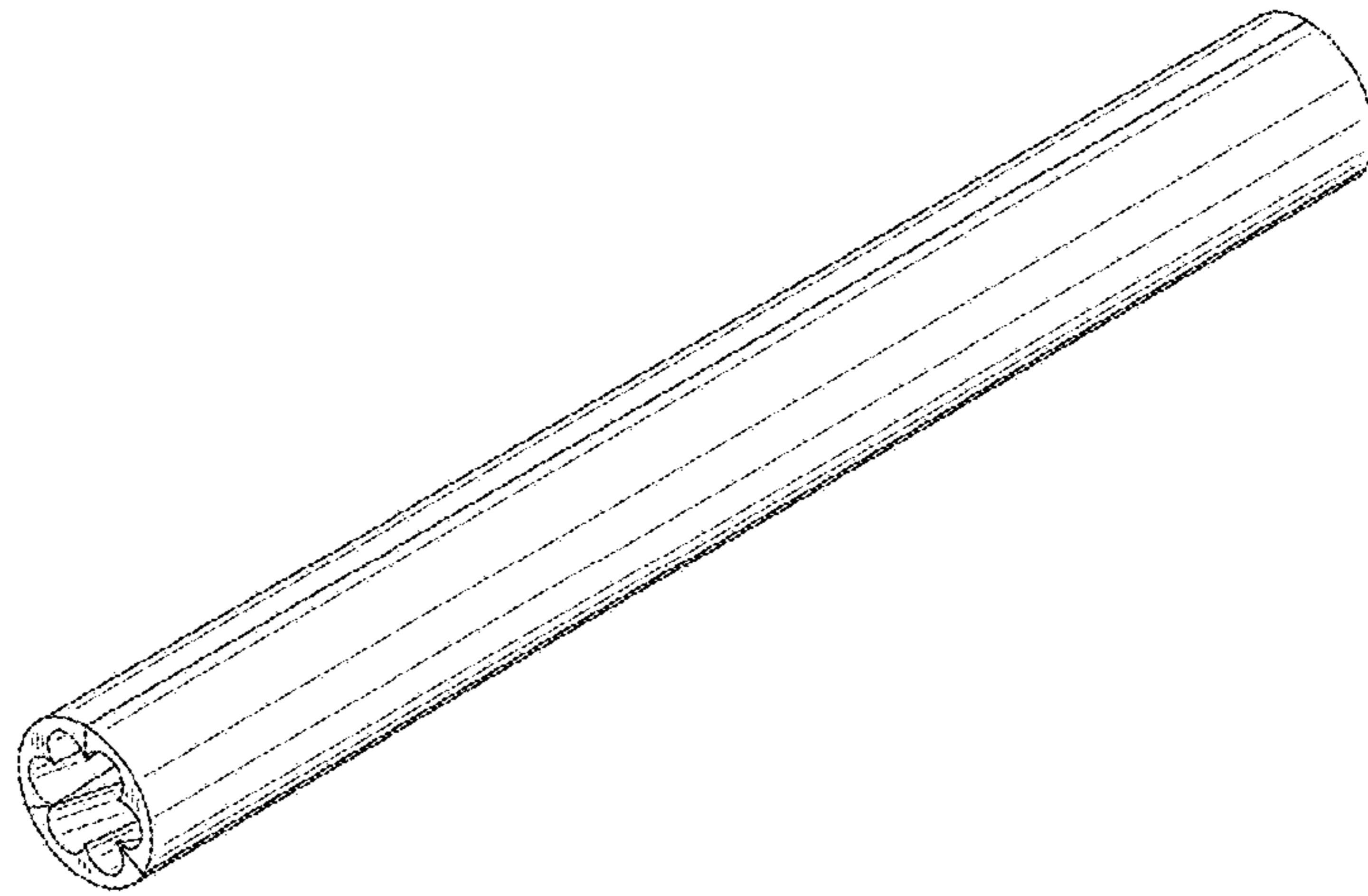

Fig. 61

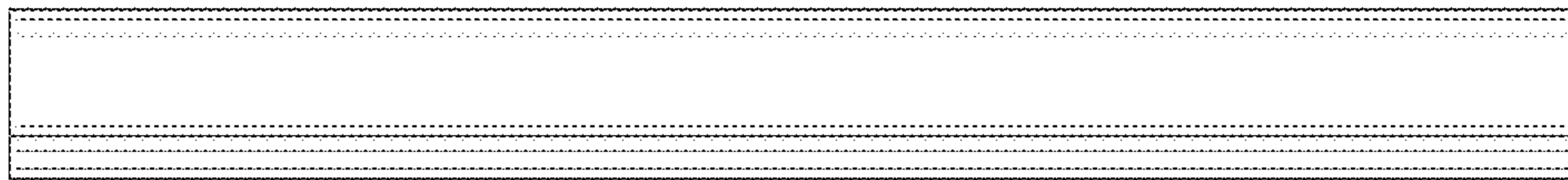

Fig. 62

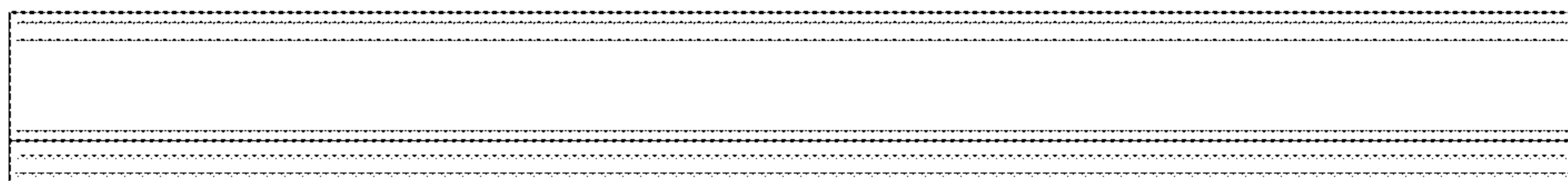

Fig. 63

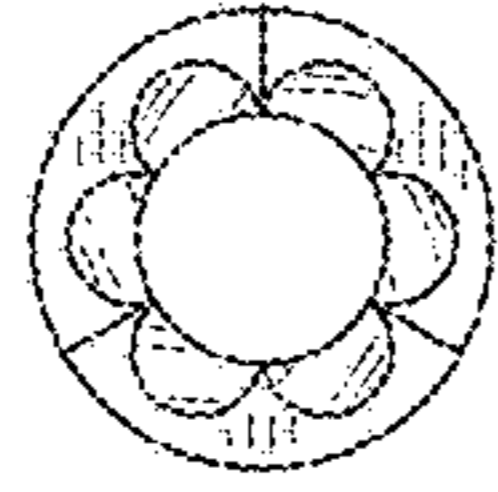

Fig. 64

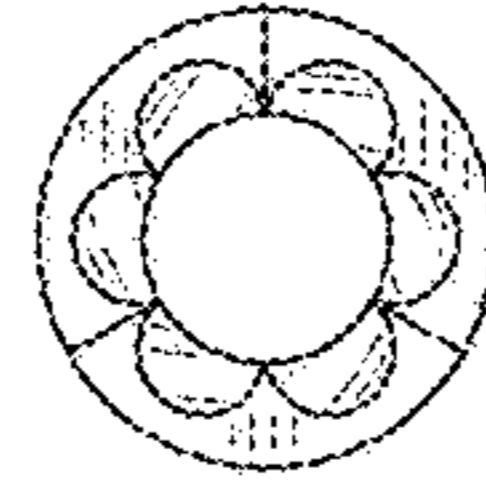

Fig. 65

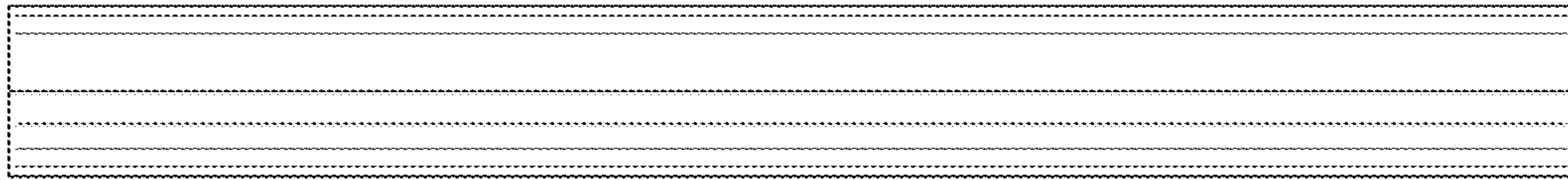

Fig. 66

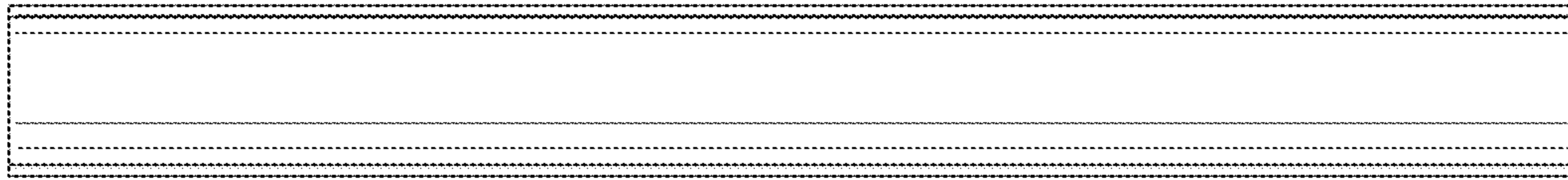

Fig. 67



Fig. 68

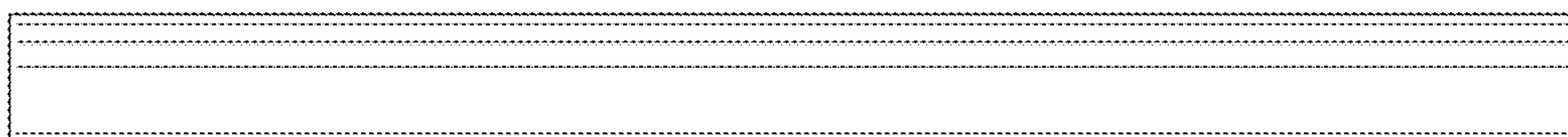

Fig. 69



Fig. 70



Fig. 71

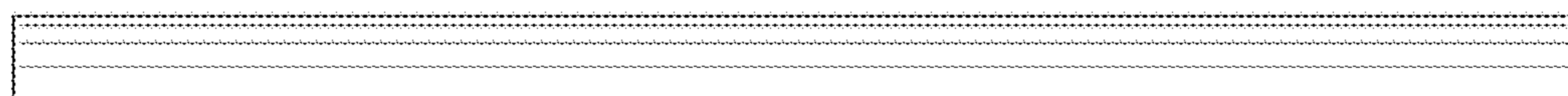

Fig. 72

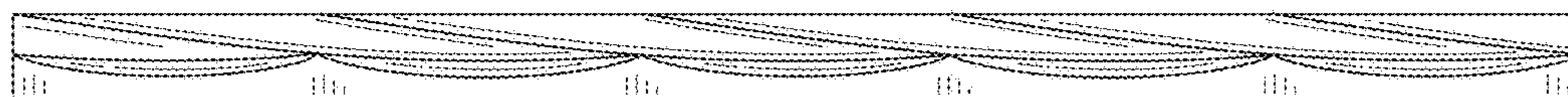

Fig. 73

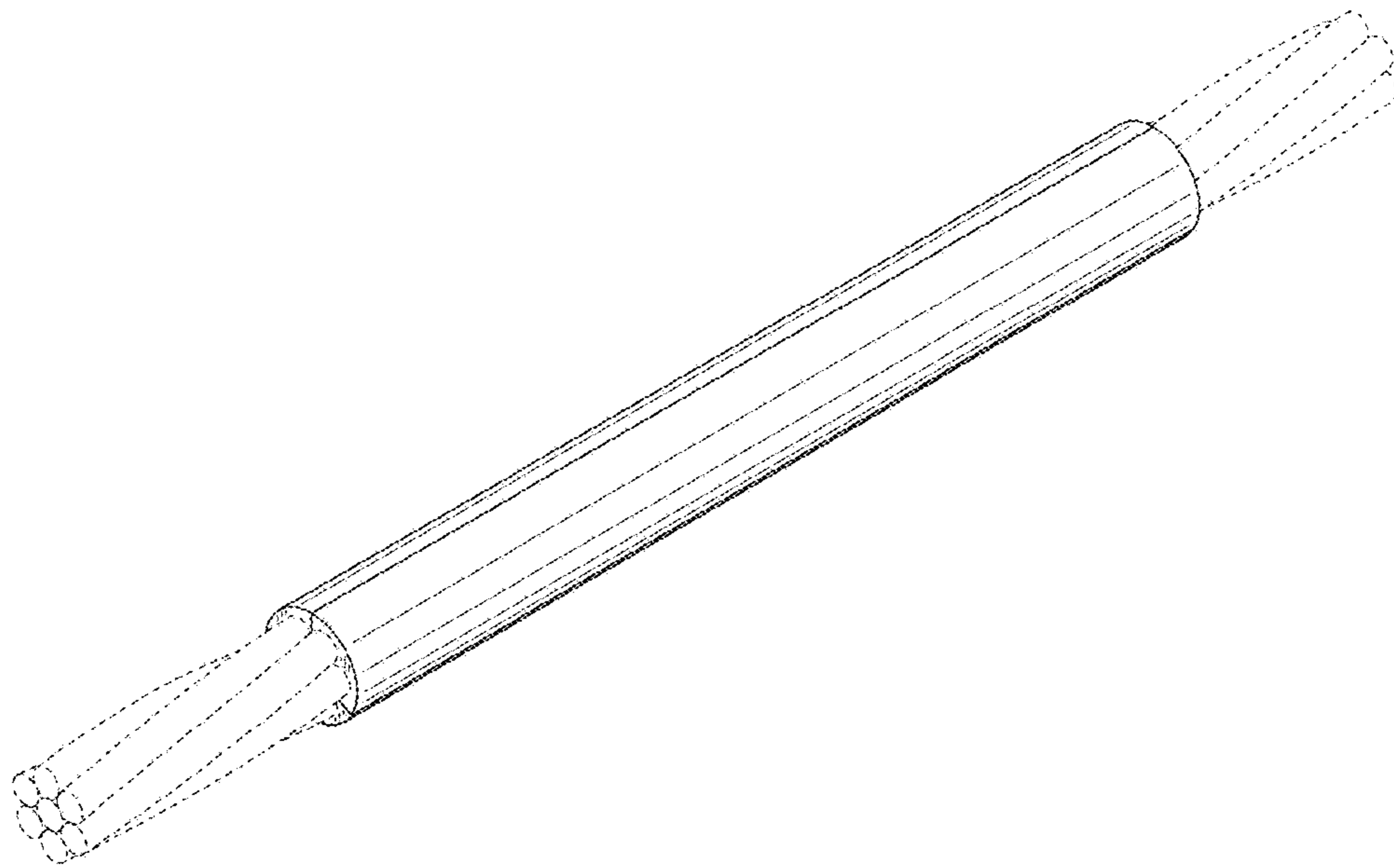

Fig. 74

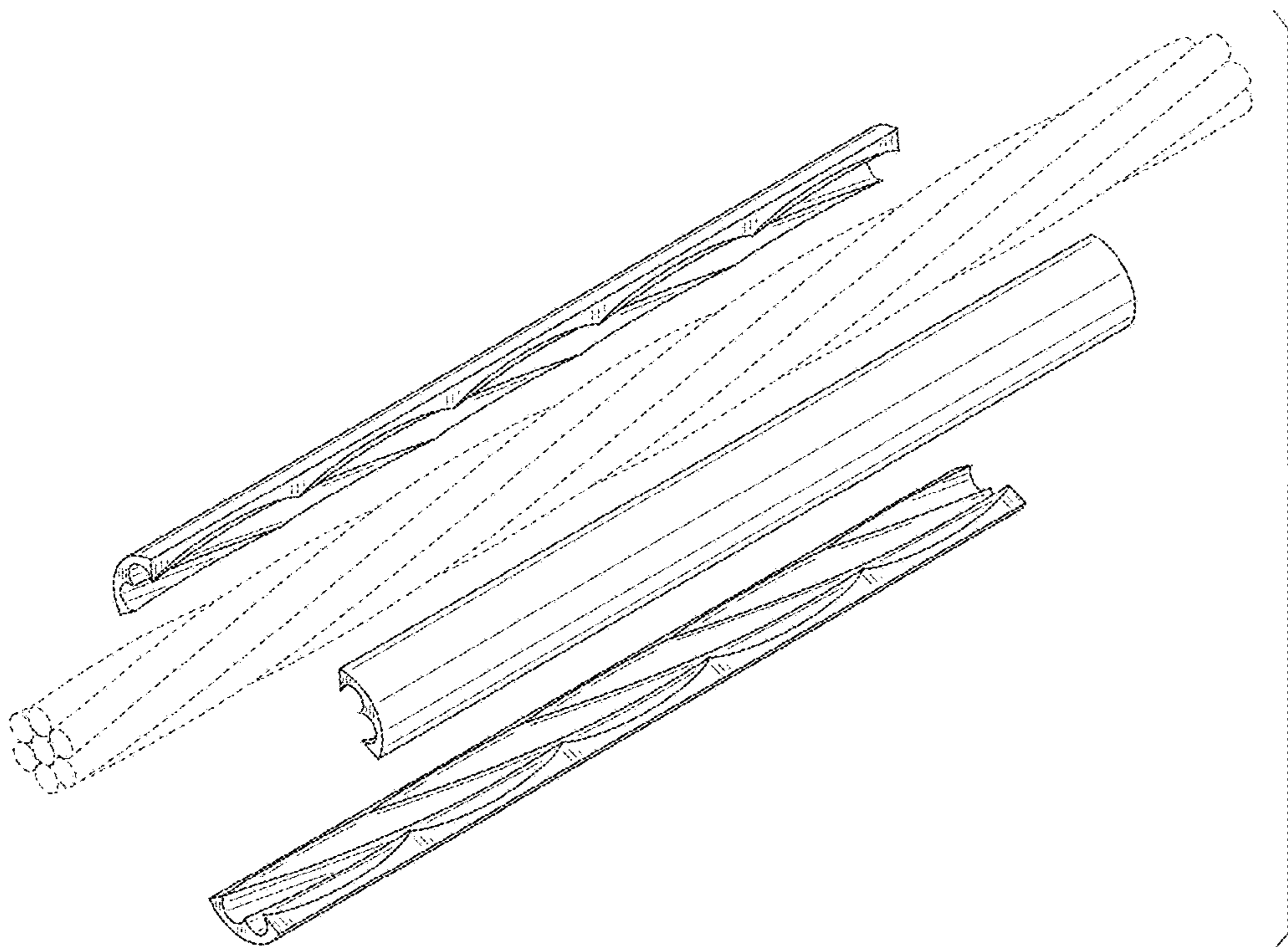

Fig. 75

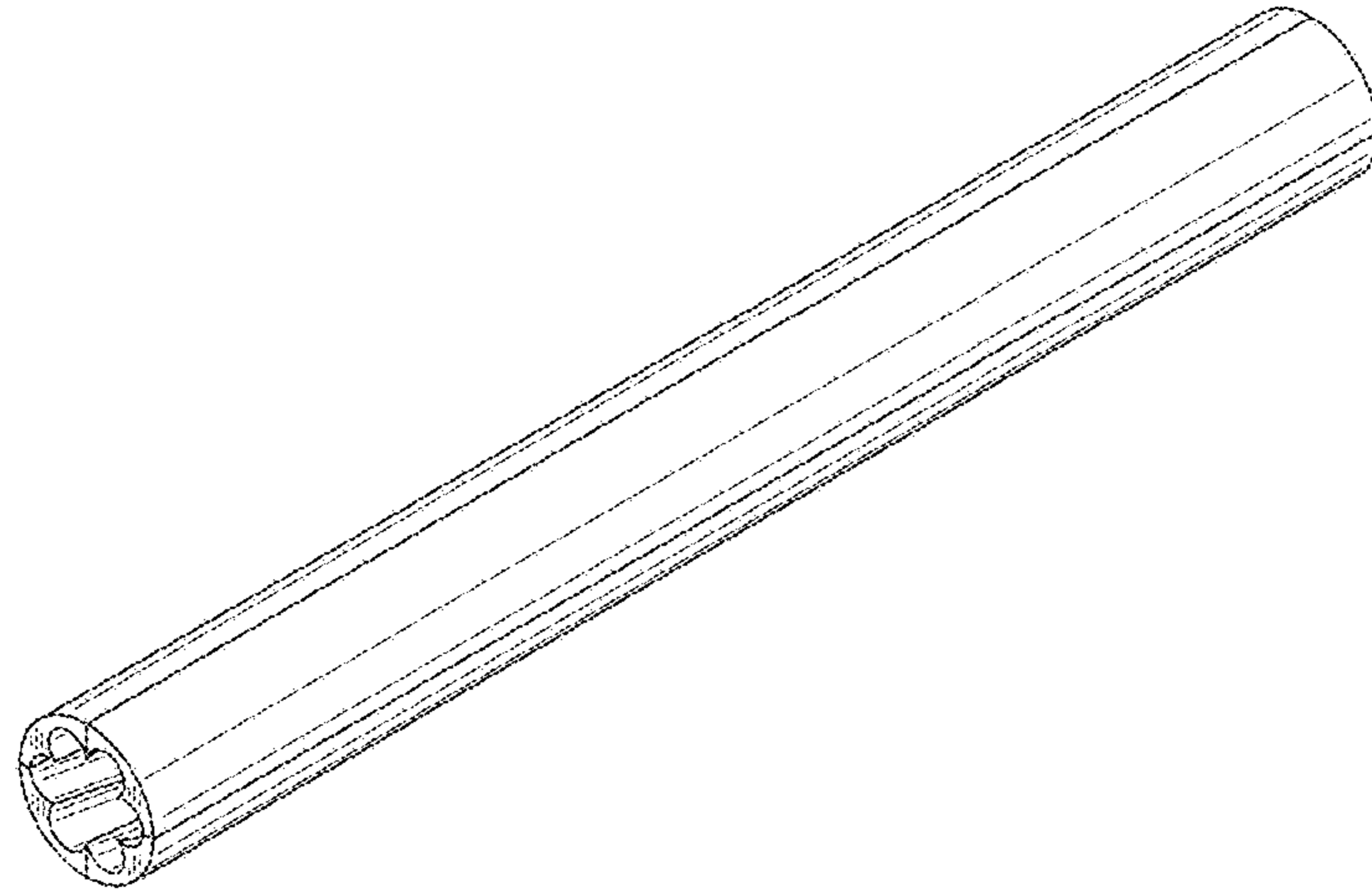

Fig. 76

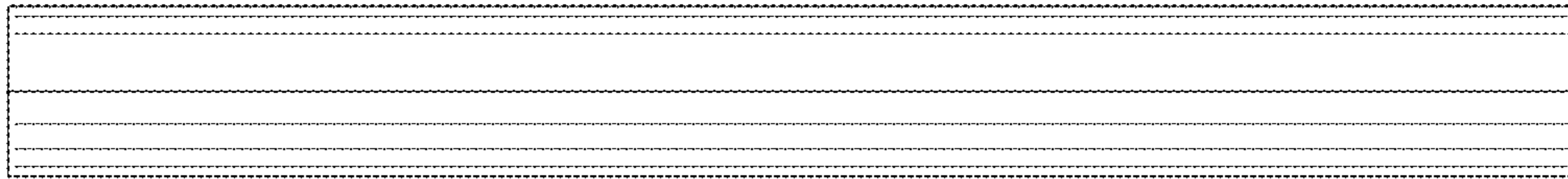

Fig. 77

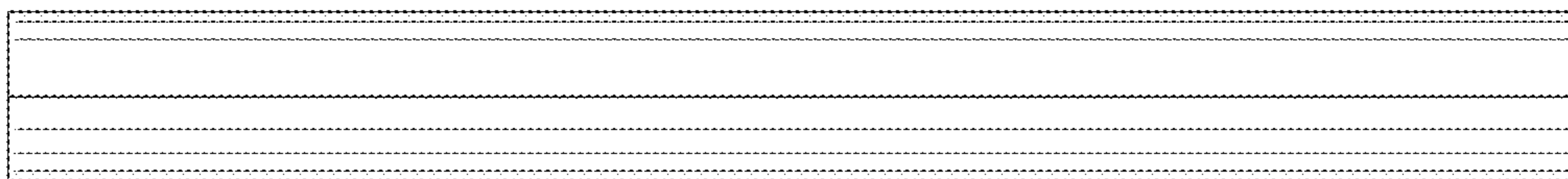

Fig. 78

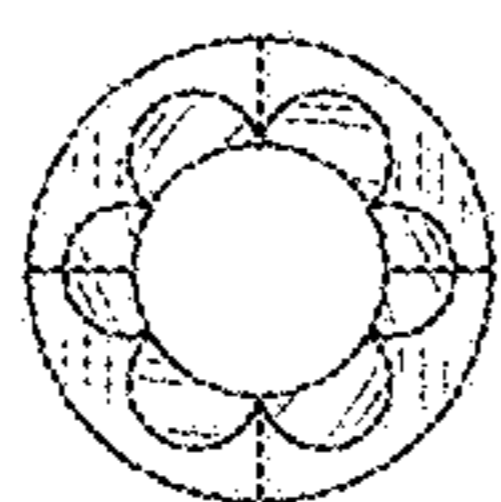

Fig. 79

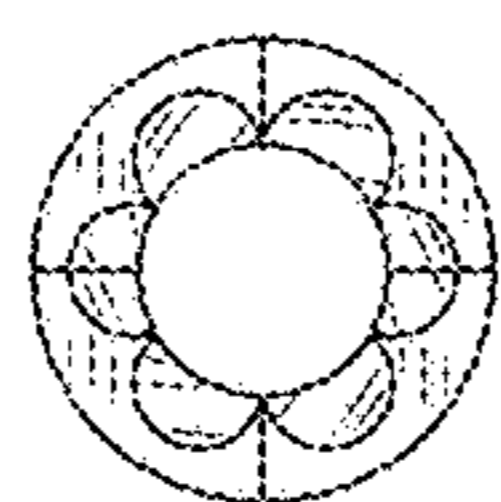

Fig. 80

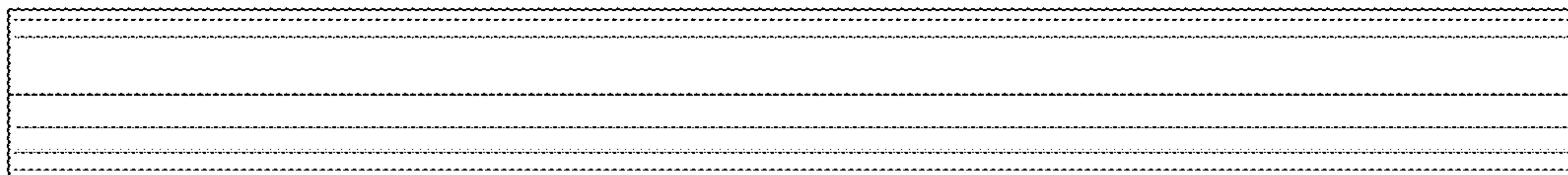

Fig. 81

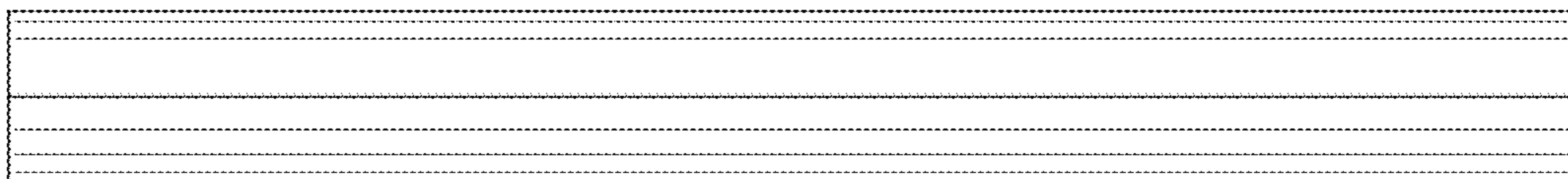

Fig. 82

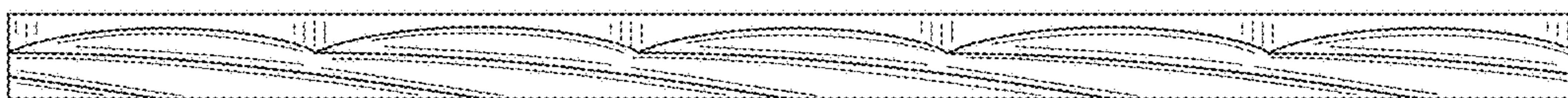

Fig. 83

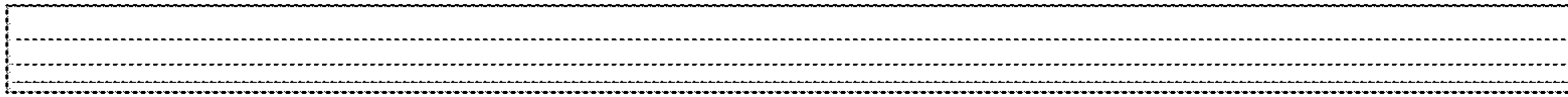

Fig. 84



Fig. 85



Fig. 86

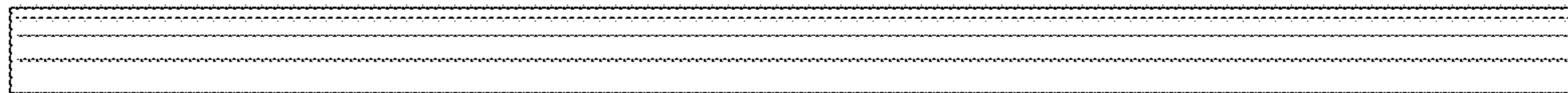

Fig. 87



Fig. 88

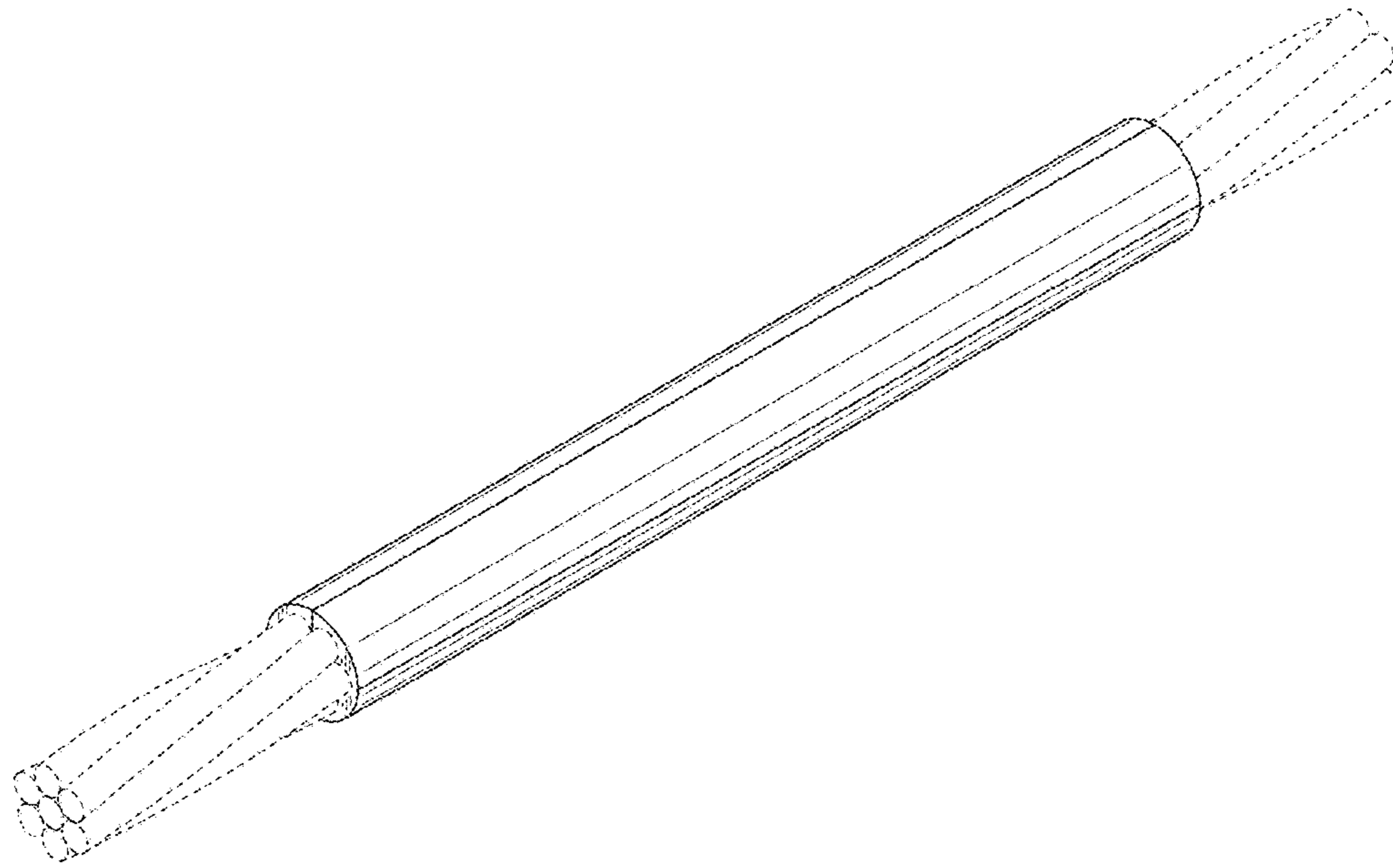

Fig. 89

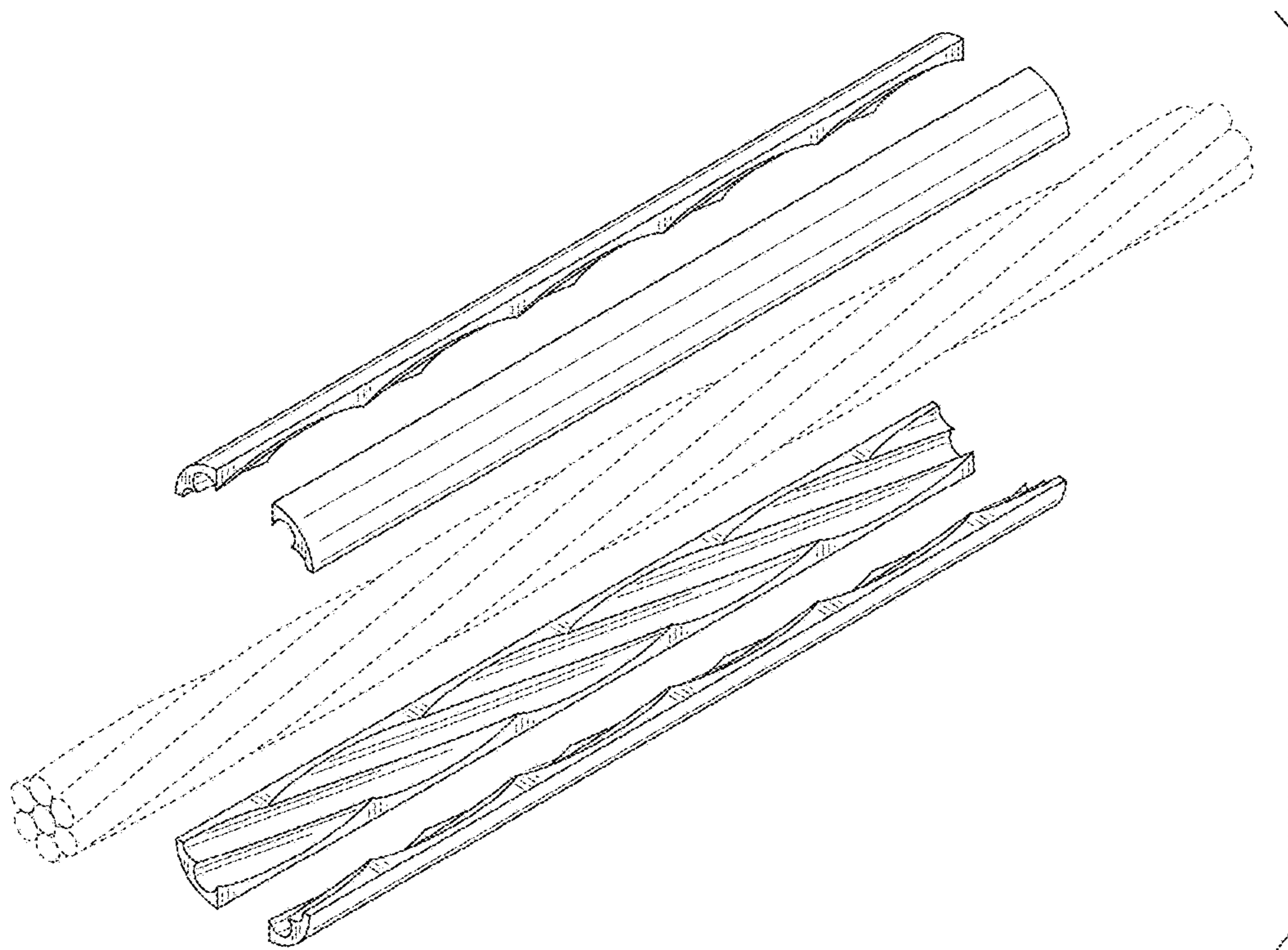

Fig. 90