



US00D775036S

(12) **United States Design Patent**
Shafer

(10) **Patent No.:** **US D775,036 S**

(45) **Date of Patent:** **** Dec. 27, 2016**

(54) **EXHAUST TIP**

(71) Applicant: **Todd John Shafer**, Ashland, OH (US)

(72) Inventor: **Todd John Shafer**, Ashland, OH (US)

(**) Term: **15 Years**

(21) Appl. No.: **29/535,388**

(22) Filed: **Aug. 6, 2015**

(51) **LOC (10) Cl.** **12-16**

(52) **U.S. Cl.**
USPC **D12/194**

(58) **Field of Classification Search**
USPC D12/400, 194, 206, 418; D15/1-6
CPC F02M 35/10032; F02M 35/14; F02M
35/10137; F02M 35/10013; F02M
35/10091; B60K 13/02; B60K 11/06
See application file for complete search history.

(56) **References Cited**

U.S. PATENT DOCUMENTS

2,000,722	A *	5/1935	Steward	F01N 13/10 181/240
2,868,229	A *	1/1959	Russell	F01N 13/20 239/132.3
D184,642	S *	3/1959	Russell	D12/194
2,909,235	A *	10/1959	Beranek	F01D 25/30 181/252
D357,665	S *	4/1995	Creyts	D12/194
D688,613	S *	8/2013	Chou	D12/194

D695,659	S *	12/2013	Chou	D12/194
D707,603	S *	6/2014	Chou	D12/194
D707,604	S *	6/2014	Chou	D12/194

* cited by examiner

Primary Examiner — Michael A Pratt

(74) *Attorney, Agent, or Firm* — Bryce D. Miracle;
Miracle IP

(57) **CLAIM**

The ornamental design for an exhaust tip, substantially as shown and described.

DESCRIPTION

FIG. 1 is a front, top side perspective view of the exhaust tip showing the new design;
 FIG. 2 is a front, top right side perspective view thereof;
 FIG. 3 is a front, top left side perspective view thereof;
 FIG. 4 is a front elevation view thereof;
 FIG. 5 is a rear elevation view thereof;
 FIG. 6 is a top plan view thereof;
 FIG. 7 is right side elevation view thereof;
 FIG. 8 is a left side elevation view thereof;
 FIG. 9 is a front, bottom right side perspective view thereof;
 FIG. 10 is a front, bottom left side perspective view thereof;
 and,
 FIG. 11 is a cross sectional view of the exhaust tip shown along line 11-11 of FIG. 1.
 The broken lines showing an exhaust pipe is included for illustrating environmental structure only and forms no part of the claimed design.

1 Claim, 4 Drawing Sheets

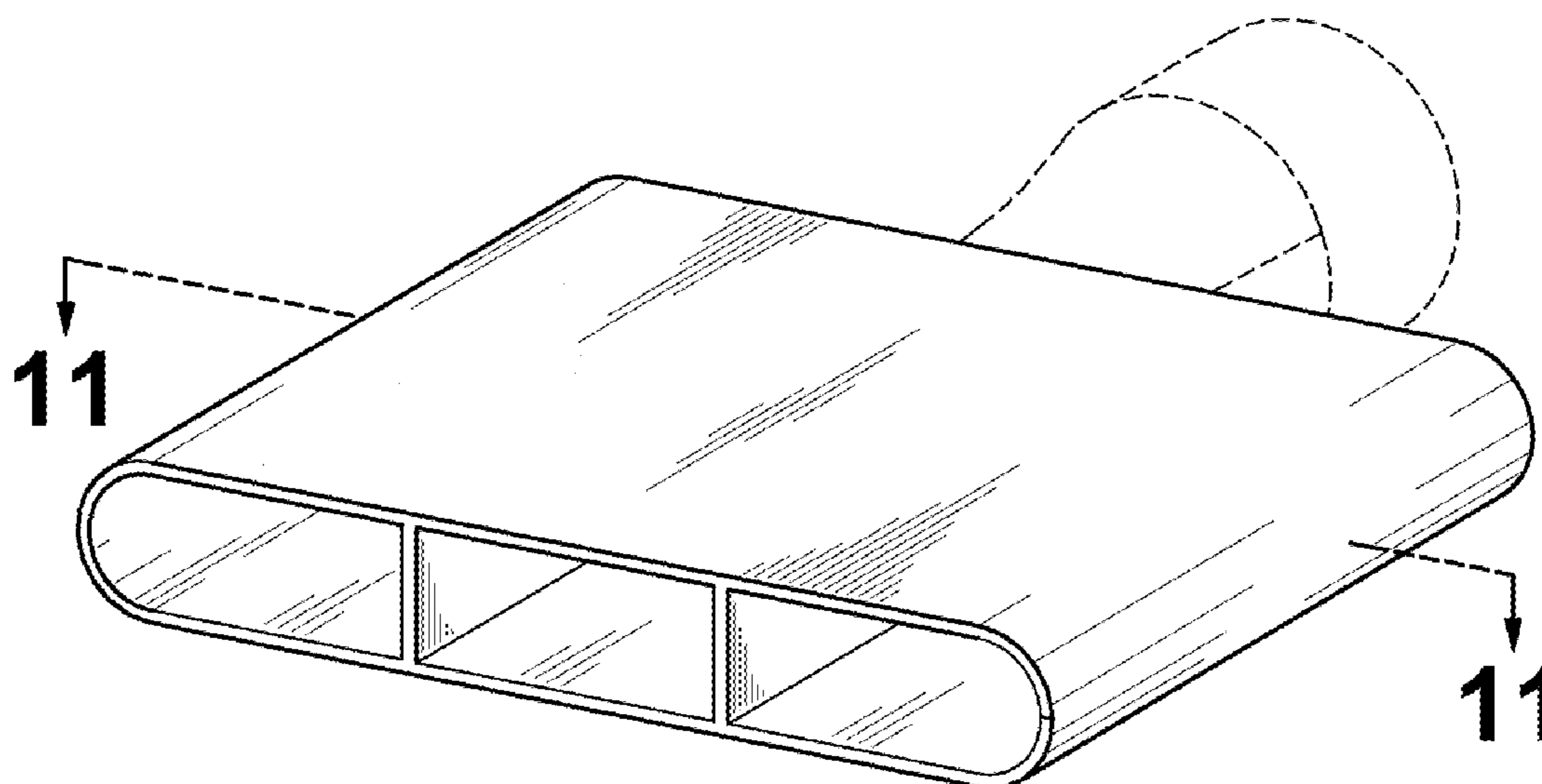

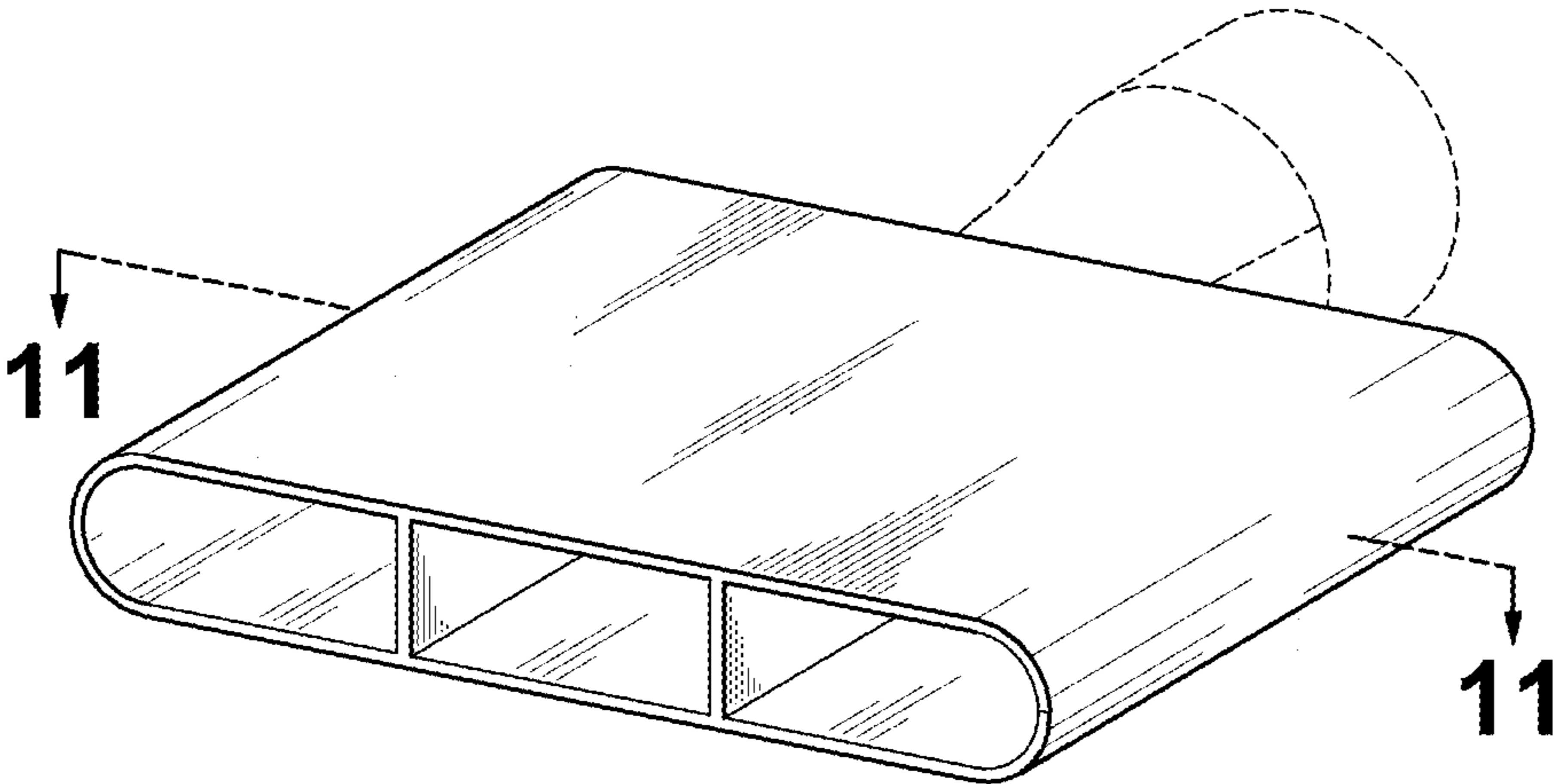

FIG. 1

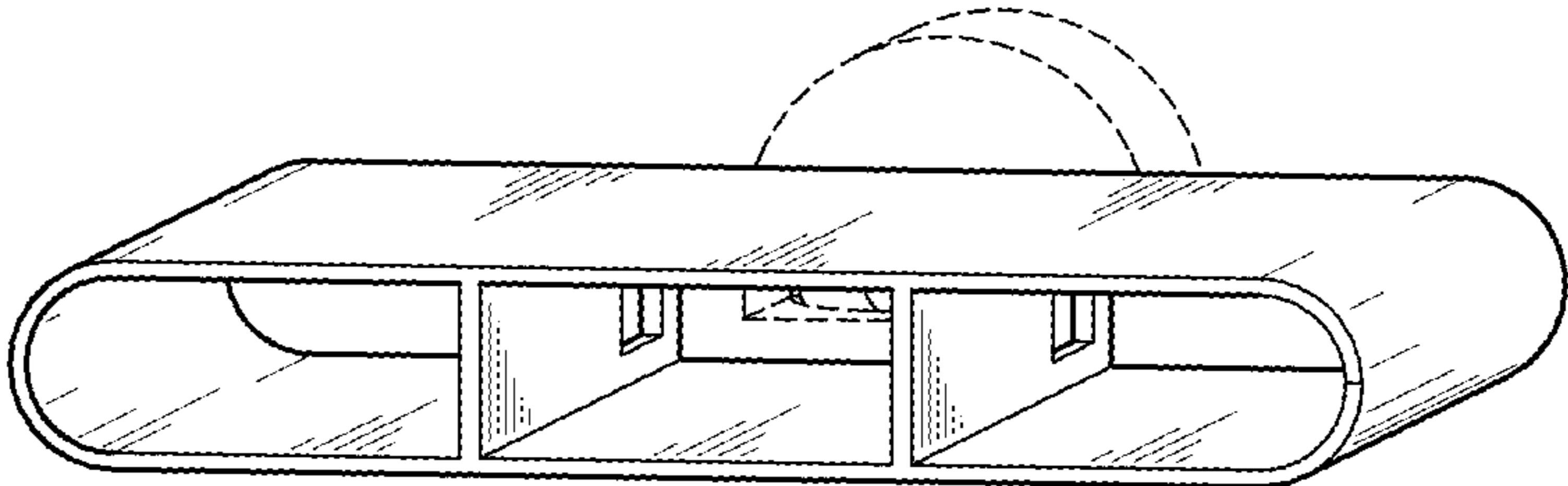

FIG. 2

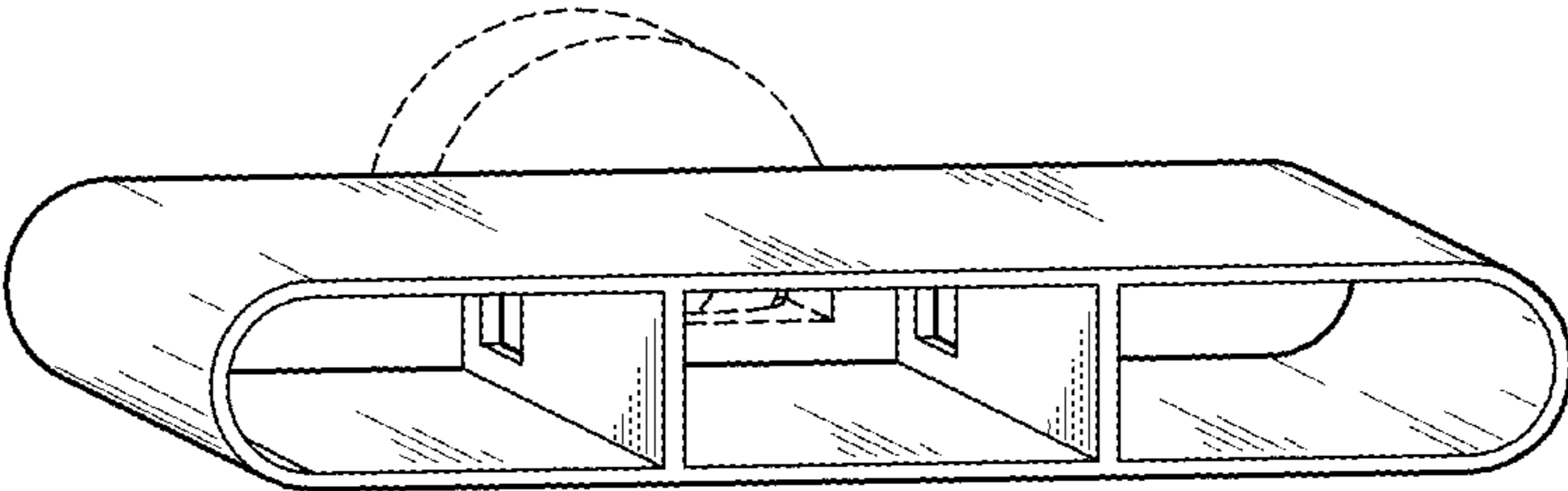

FIG. 3

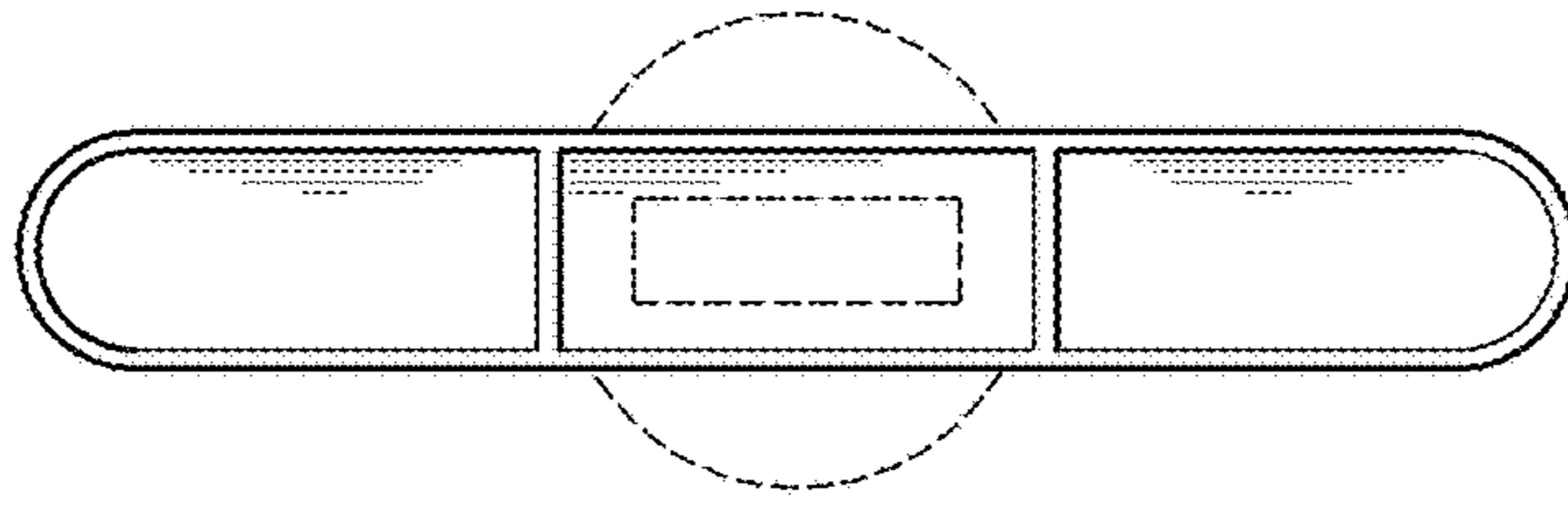

FIG. 4

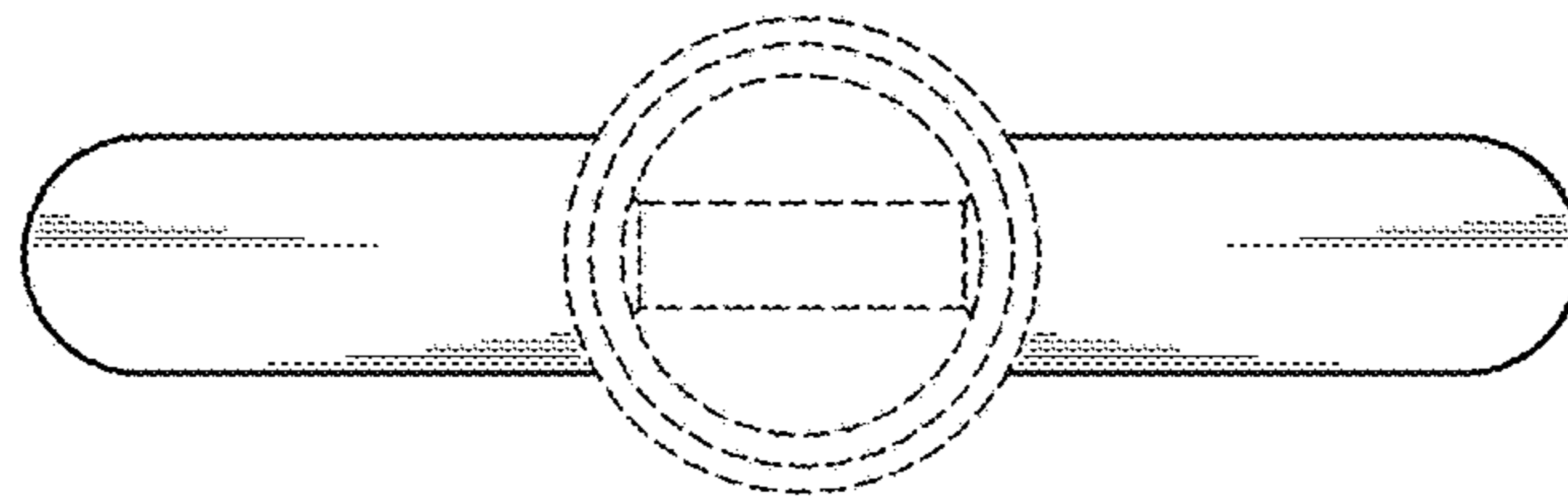

FIG. 5

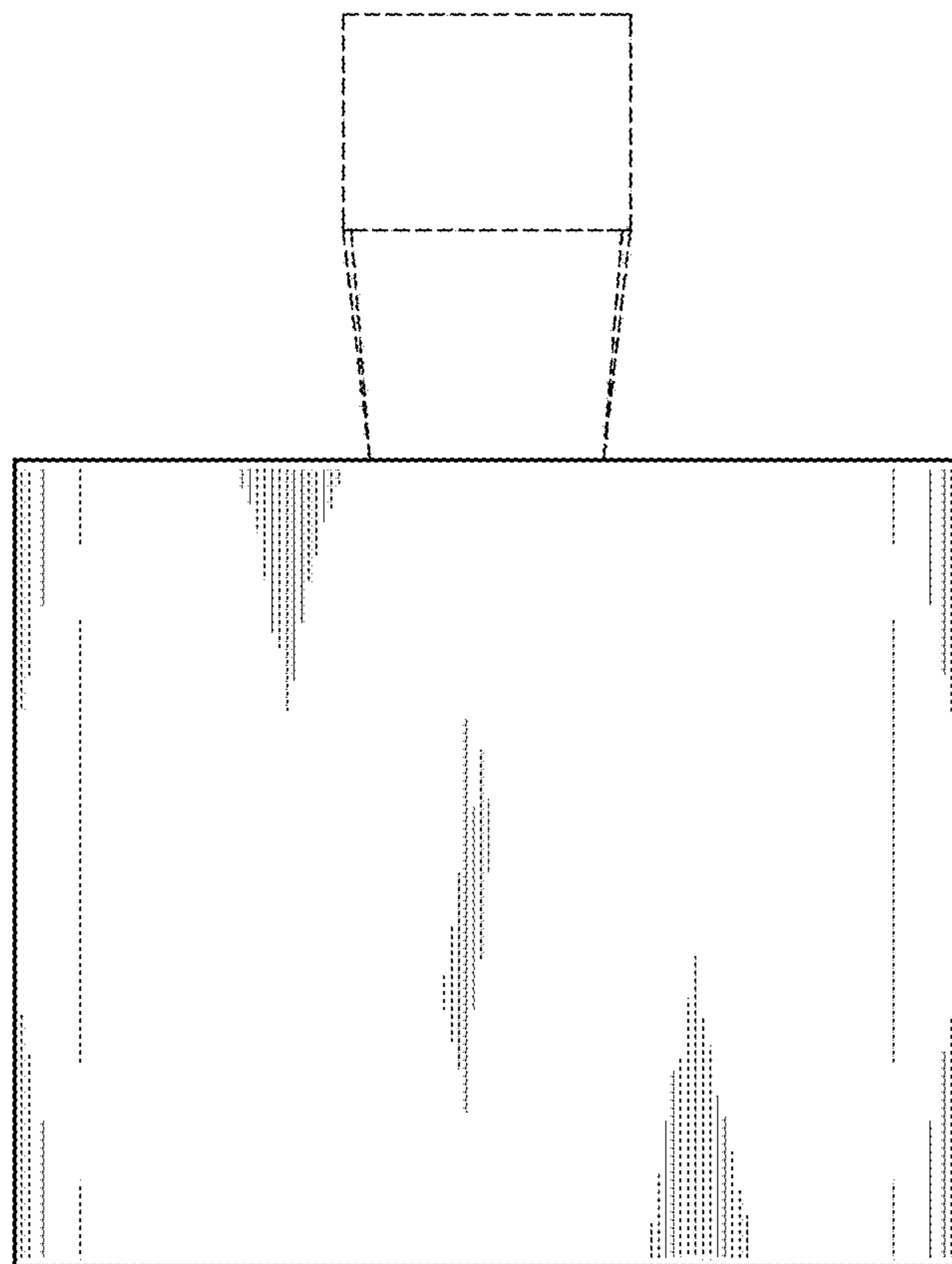

FIG. 6

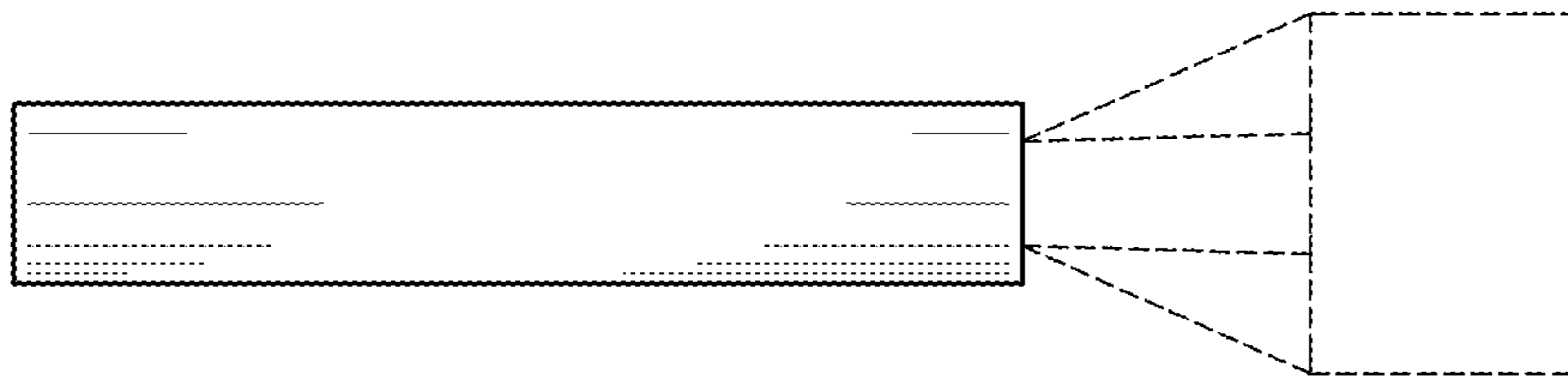

FIG. 7

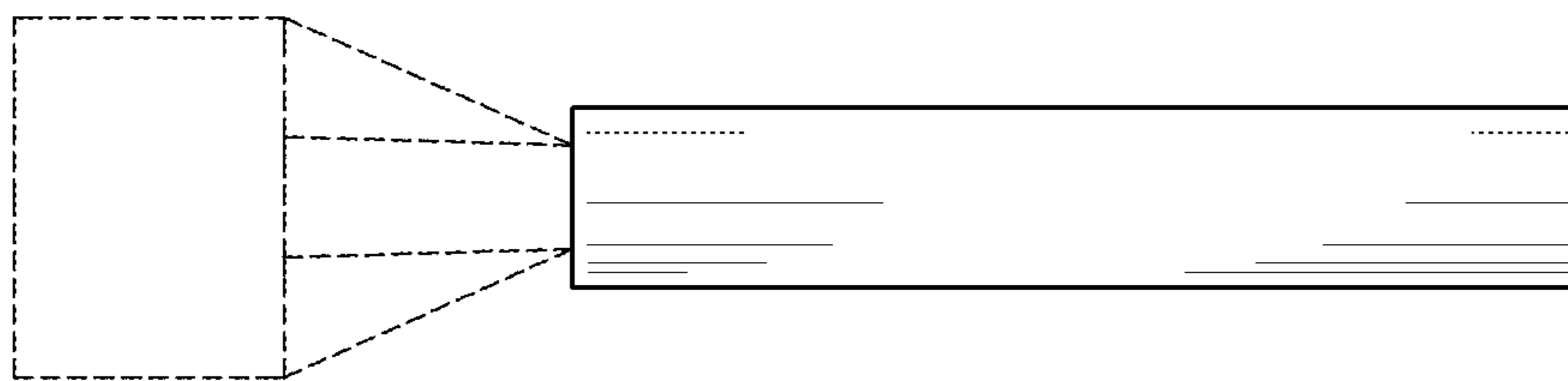

FIG. 8

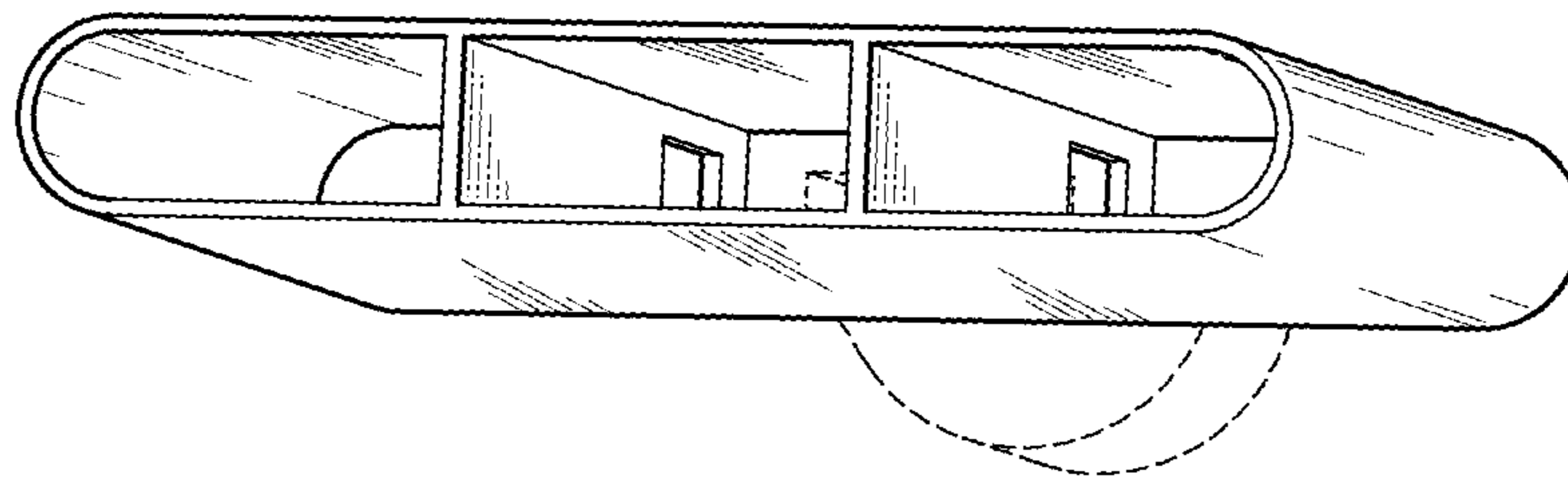

FIG. 9

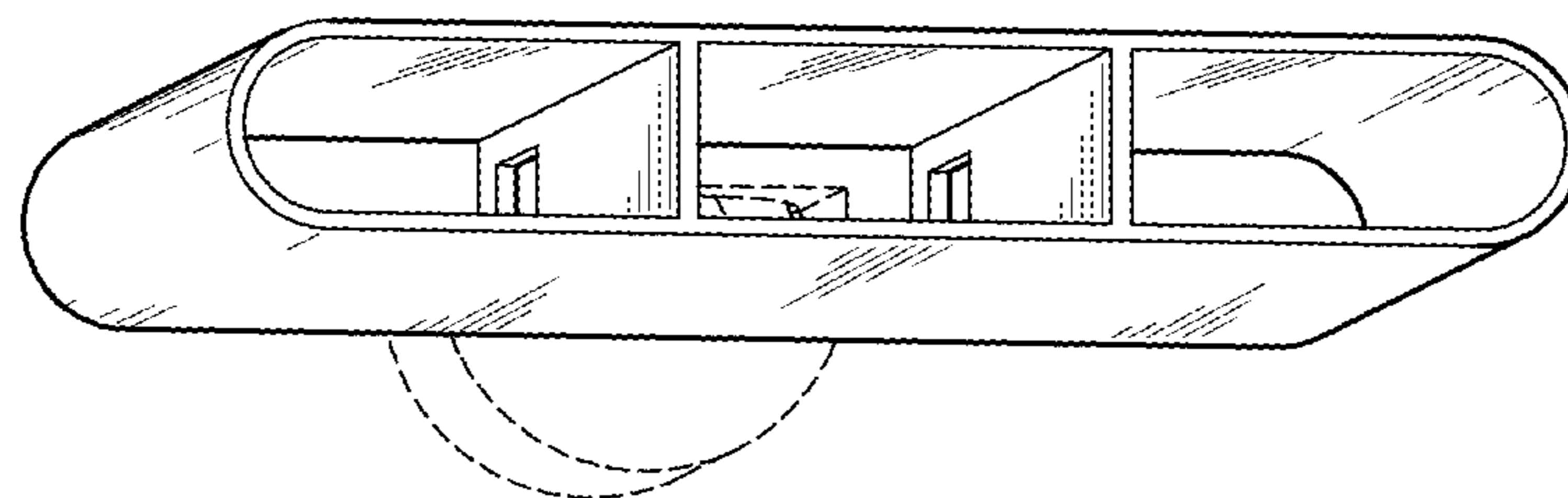

FIG. 10

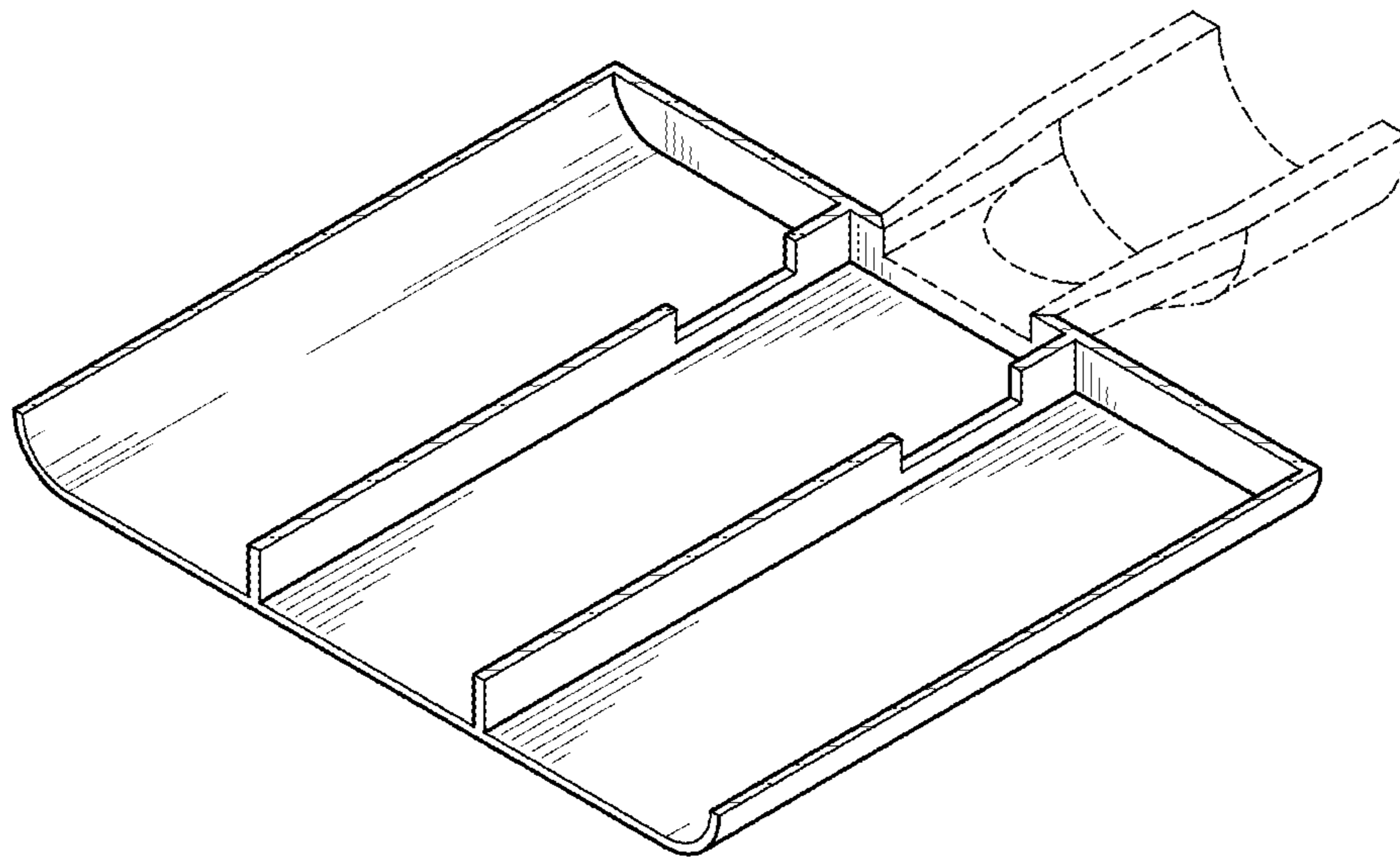

FIG. 11