



US00D774983S

(12) **United States Design Patent** (10) **Patent No.:** **US D774,983 S**
Lam (45) **Date of Patent:** **** Dec. 27, 2016**

(54) **BICYCLE FRAME INSERT**
(71) Applicant: **Trek Bicycle Corporation**, Waterloo, WI (US)

D380,510 S * 7/1997 Porkka D21/683
D381,711 S * 7/1997 Englert D21/572
D396,434 S * 7/1998 Tseng D12/111

(Continued)

(72) Inventor: **Vi Lam**, South Elgin, IL (US)
(73) Assignee: **Trek Bicycle Corporation**, Waterloo, WI (US)

OTHER PUBLICATIONS

“Trek Jet 16 inch Coaster brake BMX kids bicycle—Red/Black.” JollyMap., Sep. 28, 2014 [online], [retrieved on Apr. 17, 2015]. Retrieved from the Internet <URL: <http://www.jollymap.com/en/kids-bikes/422-trek-jet-16-inch-coaster-brake-bmx-kids-bicycle-red-black.html>>.*

(**) Term: **14 Years**

Primary Examiner — Darlington Ly

(21) Appl. No.: **29/491,772**

(57) **CLAIM**

(22) Filed: **May 23, 2014**

The ornamental design for a bicycle frame insert, as shown and described.

(51) **LOC (10) Cl.** **12-11**

(52) **U.S. Cl.**
USPC **D12/117**

DESCRIPTION

(58) **Field of Classification Search**
USPC D12/111, 114, 117; 280/274–280, 281.1, 280/283–288, 288.1–288.4
CPC B62K 3/00; B62K 3/005; B62K 9/00; B62K 19/00; B62K 19/02; B62K 19/04; B62K 19/06; B62K 19/16
See application file for complete search history.

This application is related to U.S. Design patent application Ser. Nos. 29/491,777, titled “Saddle with Grips,” and 29/491,778, titled “Bicycle with Integrated Accessories,” both of which are concurrently filed.

FIG. 1 is a top view of a frame insert showing my new design;

FIG. 2 is a bottom view thereof;

FIG. 3 is a left view thereof;

FIG. 4 is right view thereof;

FIG. 5 is a rear view thereof;

FIG. 6 is a front view thereof;

FIG. 7 is a bottom, front, and left-side perspective view thereof;

FIG. 8 is a top, rear and left-side perspective view thereof;

FIG. 9 is a top, front and right-side perspective view thereof; and,

FIG. 10 is a bottom, rear and right-side perspective view thereof.

The broken lines in the drawings illustrate portions of the bicycle frame insert that forms no part of the claimed design.

(56) **References Cited**

U.S. PATENT DOCUMENTS

D245,412 S * 8/1977 Ray D12/126
D246,170 S * 10/1977 Powers D12/111
D246,779 S * 12/1977 Cognata D12/126
D250,329 S * 11/1978 Breen D12/126
D326,247 S * 5/1992 Hess D12/111
D342,221 S * 12/1993 De Silva D12/114
D343,599 S * 1/1994 Camfield et al. D12/11
D345,325 S * 3/1994 Camfield et al. D12/117
D359,467 S * 6/1995 Hsieh D12/117
D374,848 S * 10/1996 Liles et al. D12/114
D376,123 S * 12/1996 Camfield D12/114
D376,775 S * 12/1996 Fang D12/117

1 Claim, 5 Drawing Sheets

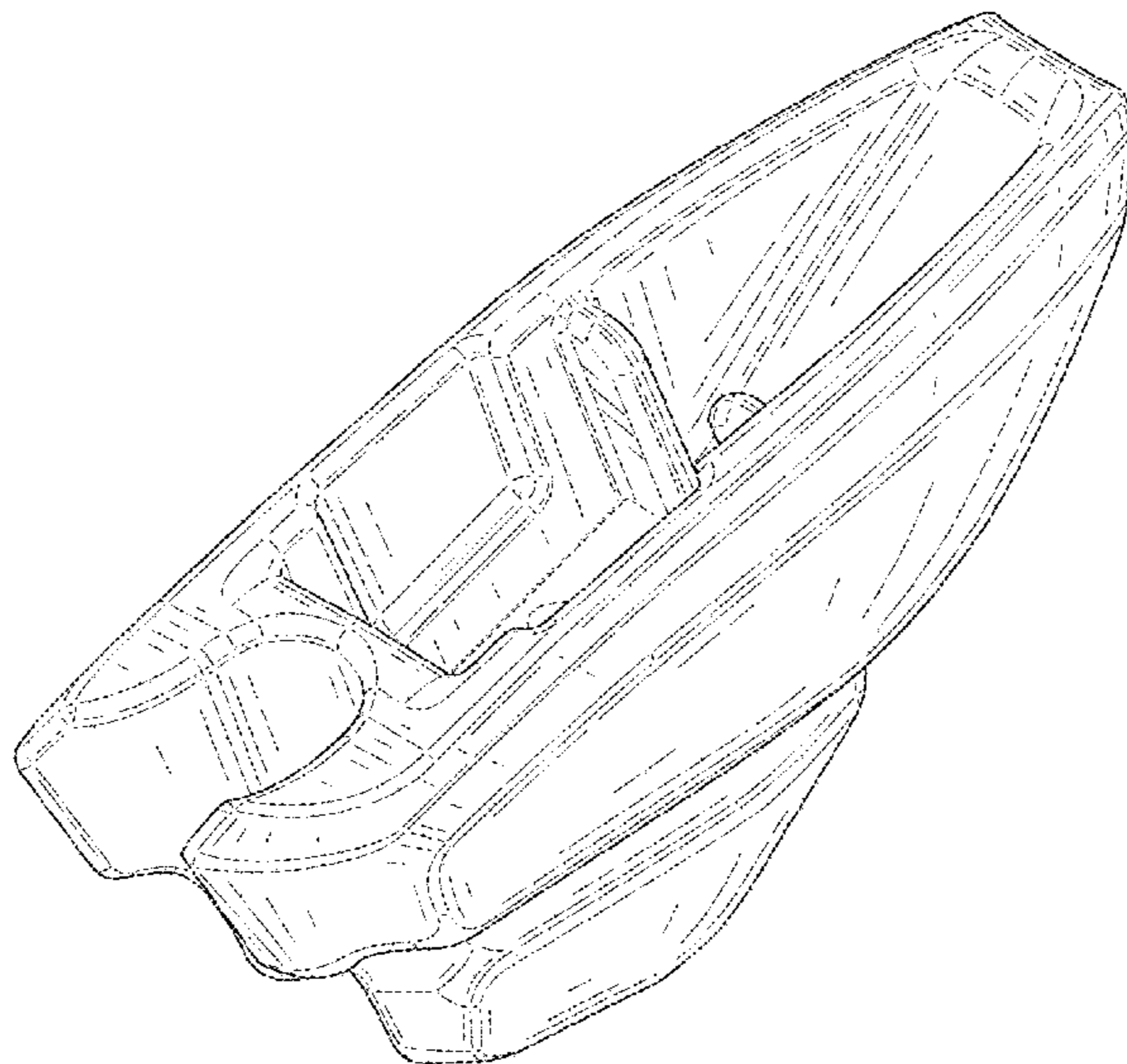

(56)

References Cited

U.S. PATENT DOCUMENTS

D409,528 S *	5/1999	Huang	D12/111
D421,937 S *	3/2000	Huang	D12/111
D447,094 S *	8/2001	Conte	D12/114
D466,471 S *	12/2002	Chen	D12/407
D550,592 S *	9/2007	Wu	D12/114
D626,493 S *	11/2010	Dallaire et al.	D12/407
D685,687 S *	7/2013	Richter	D12/114
D722,540 S *	2/2015	Brunner et al.	D12/114

* cited by examiner

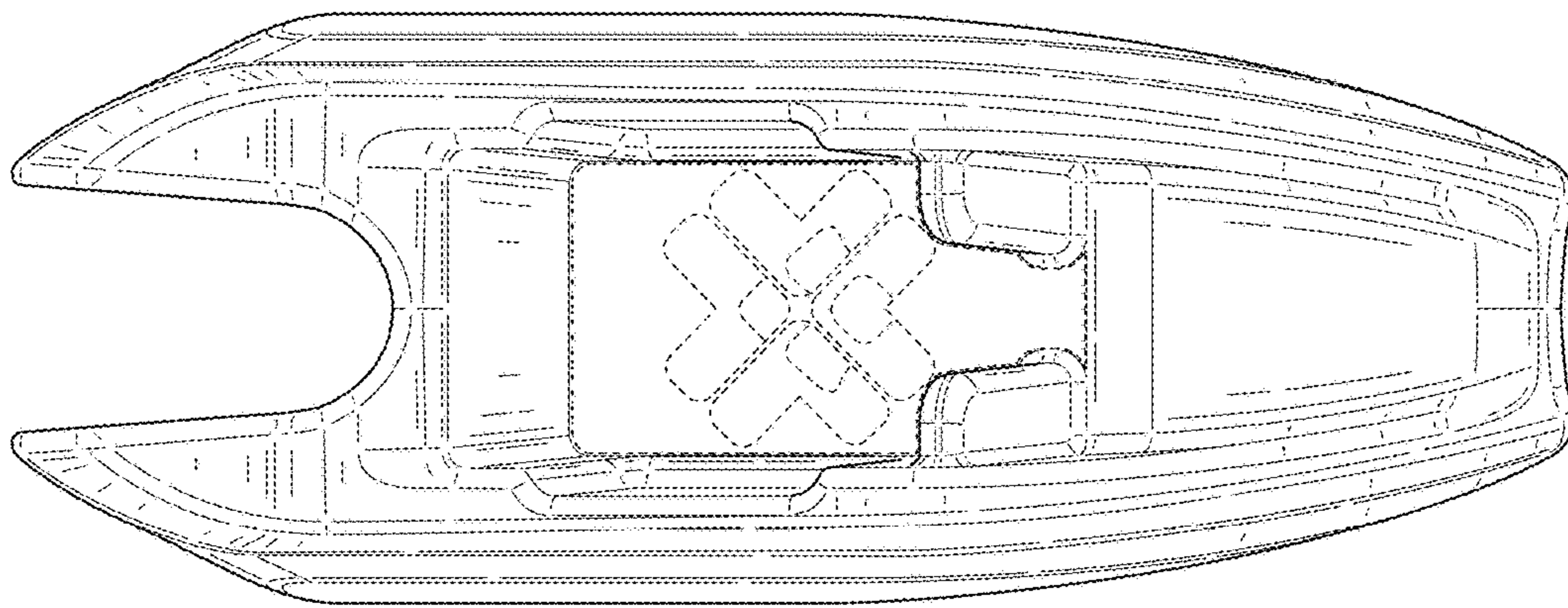

FIG. 1

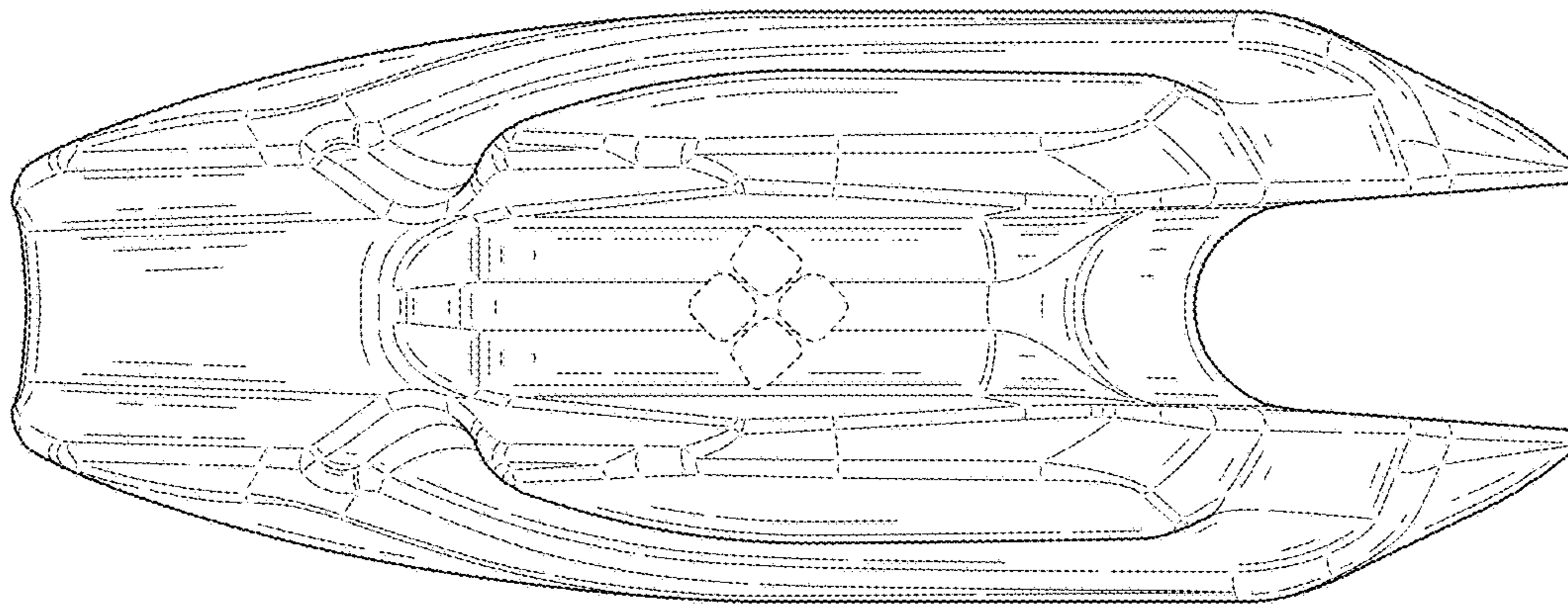

FIG. 2

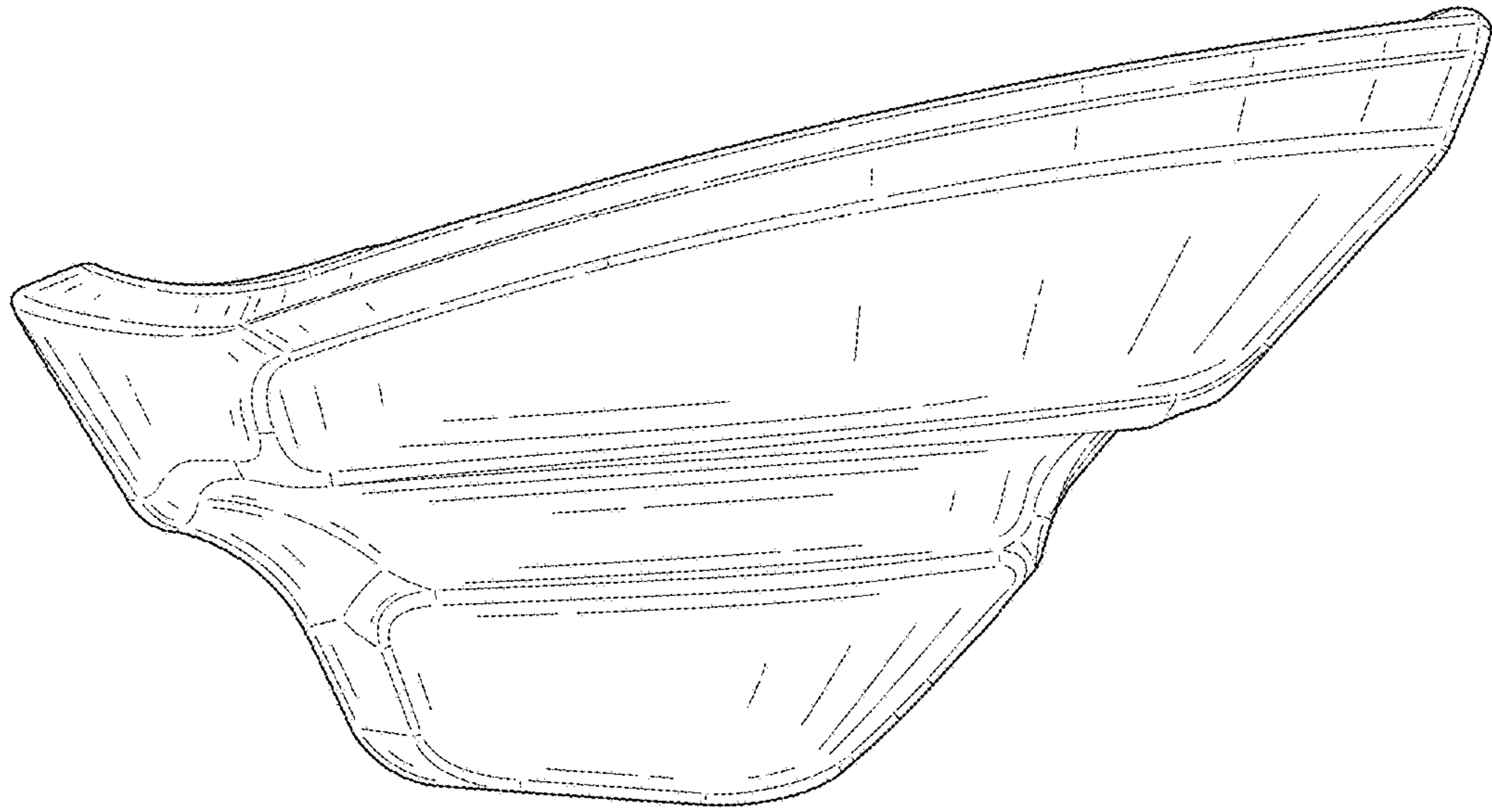

FIG. 3

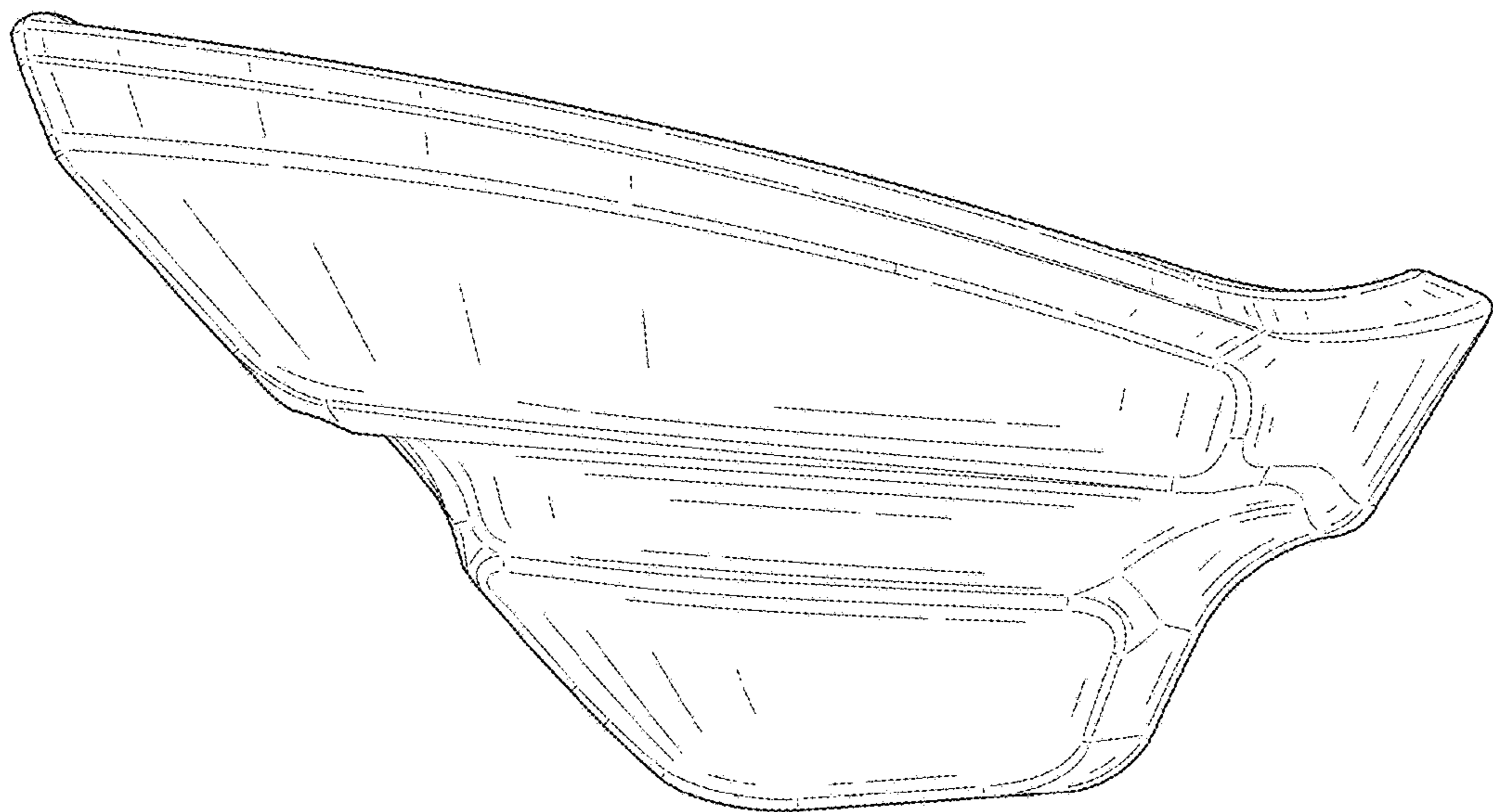

FIG. 4

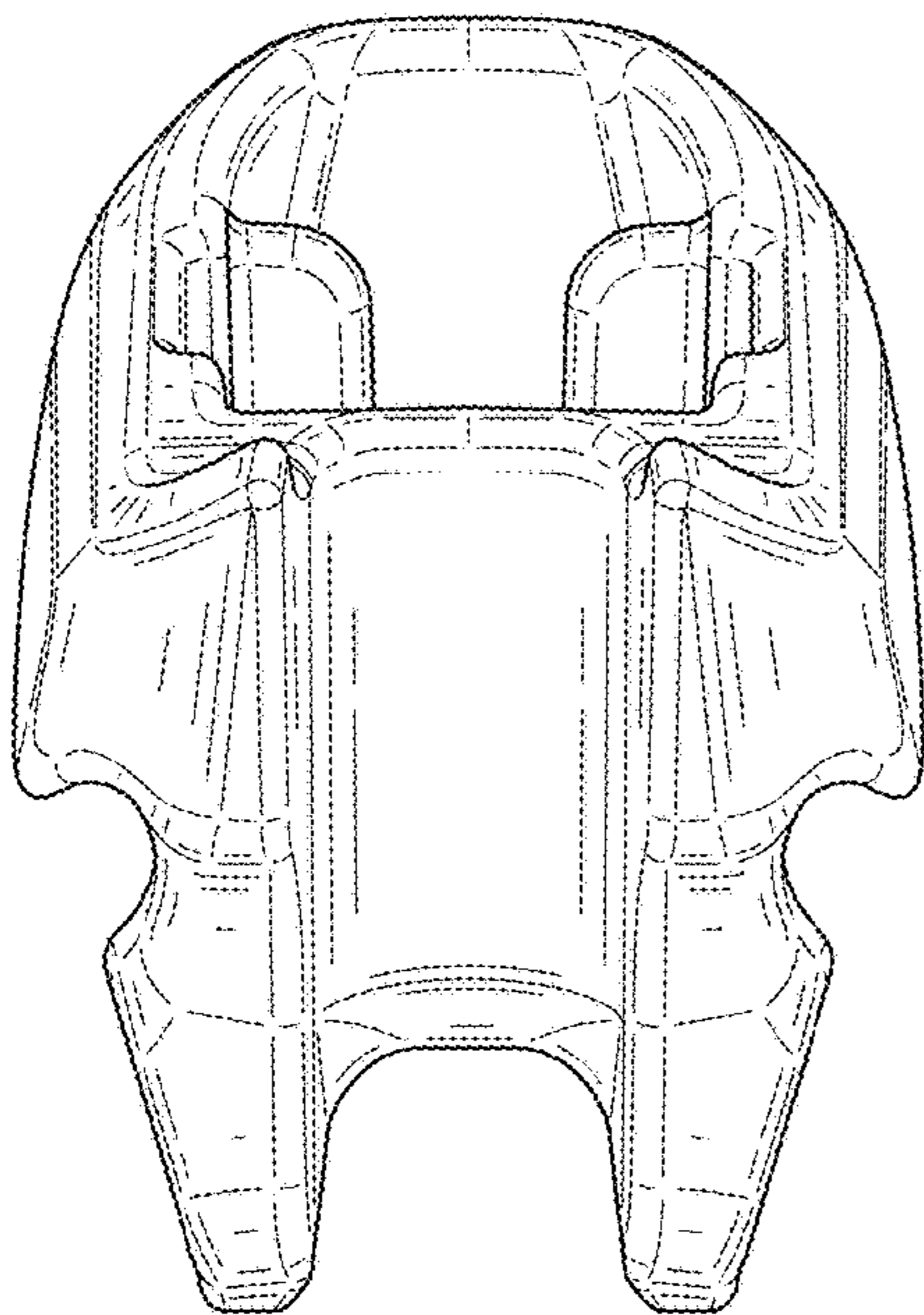

FIG. 5

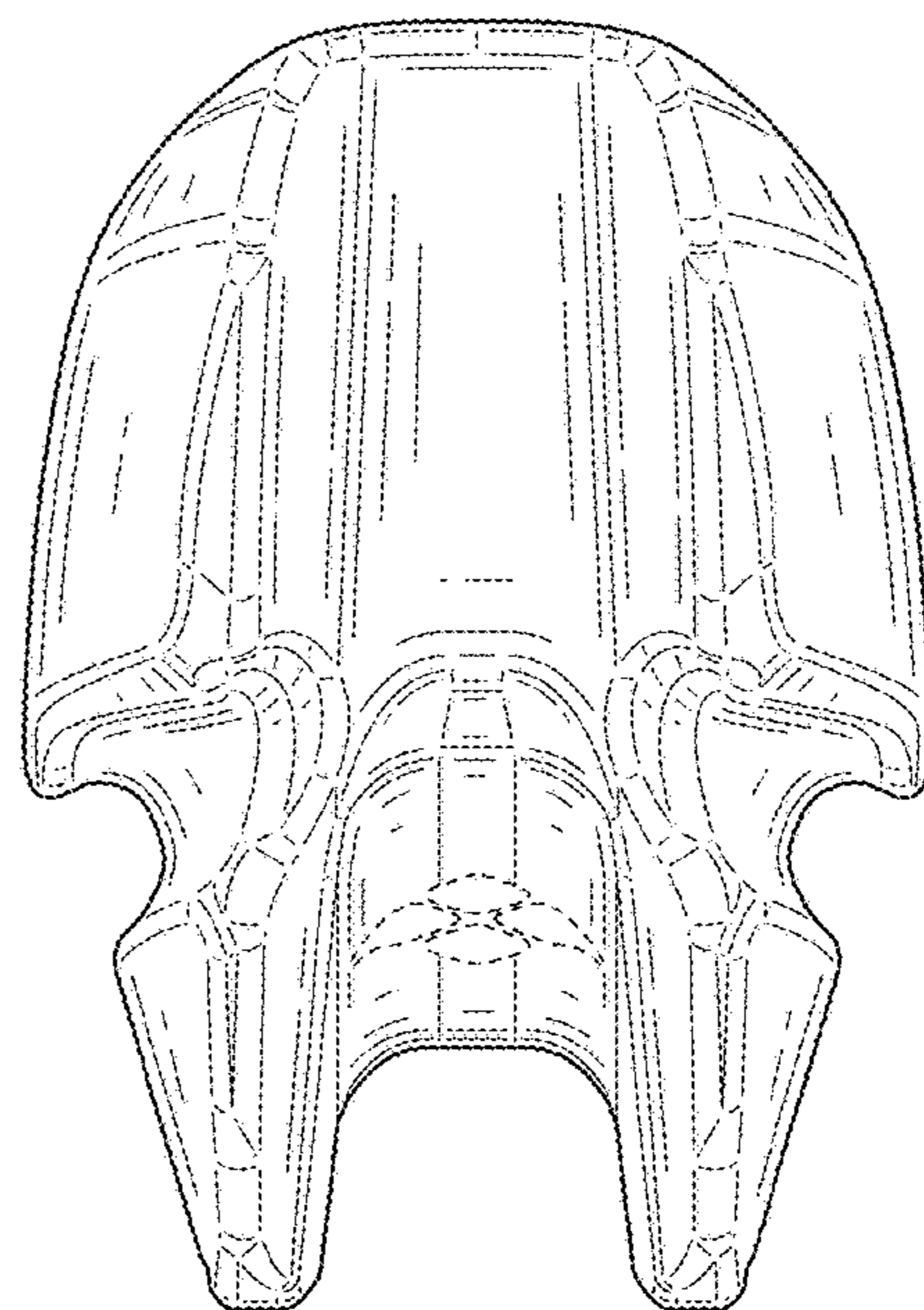
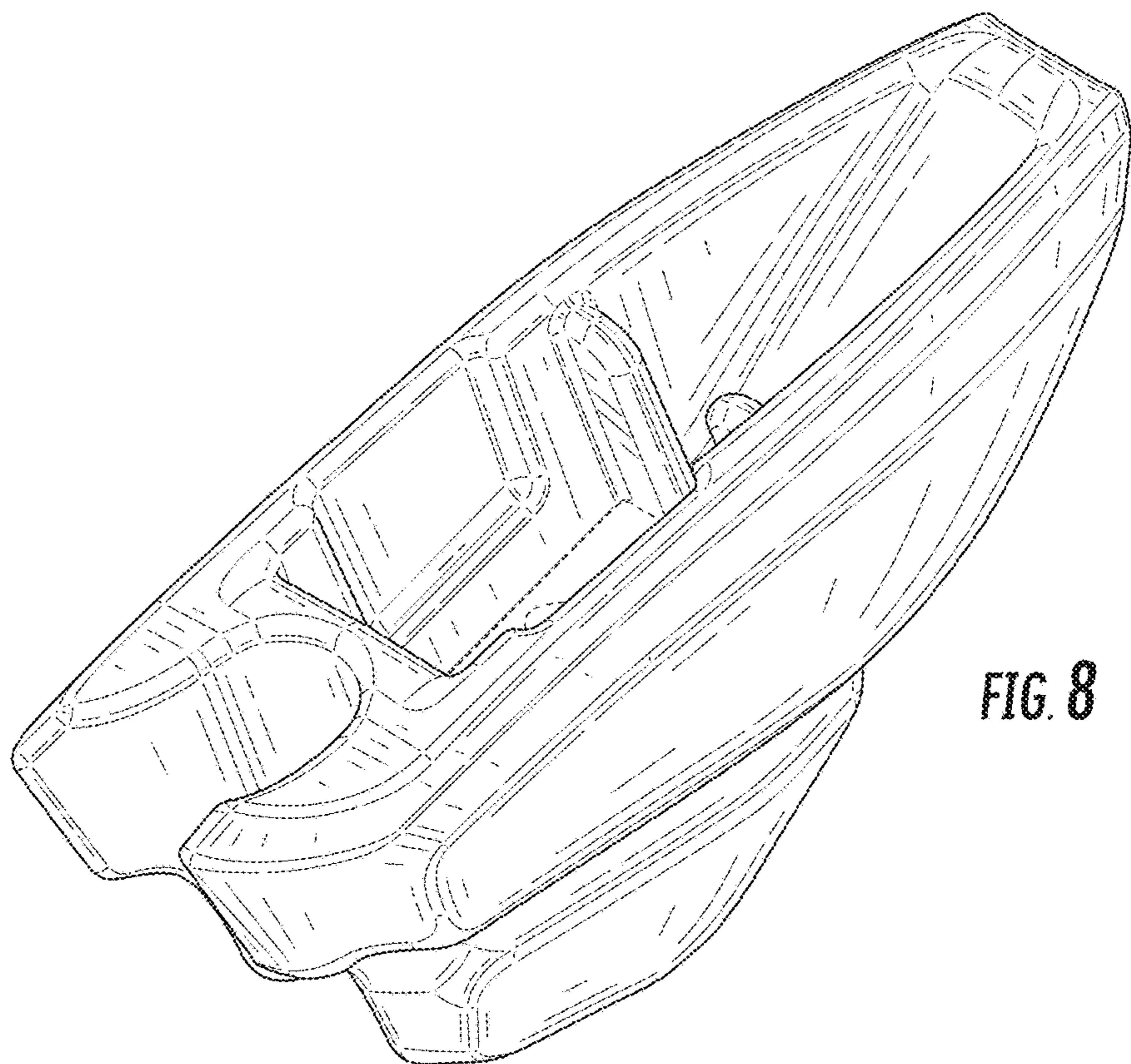
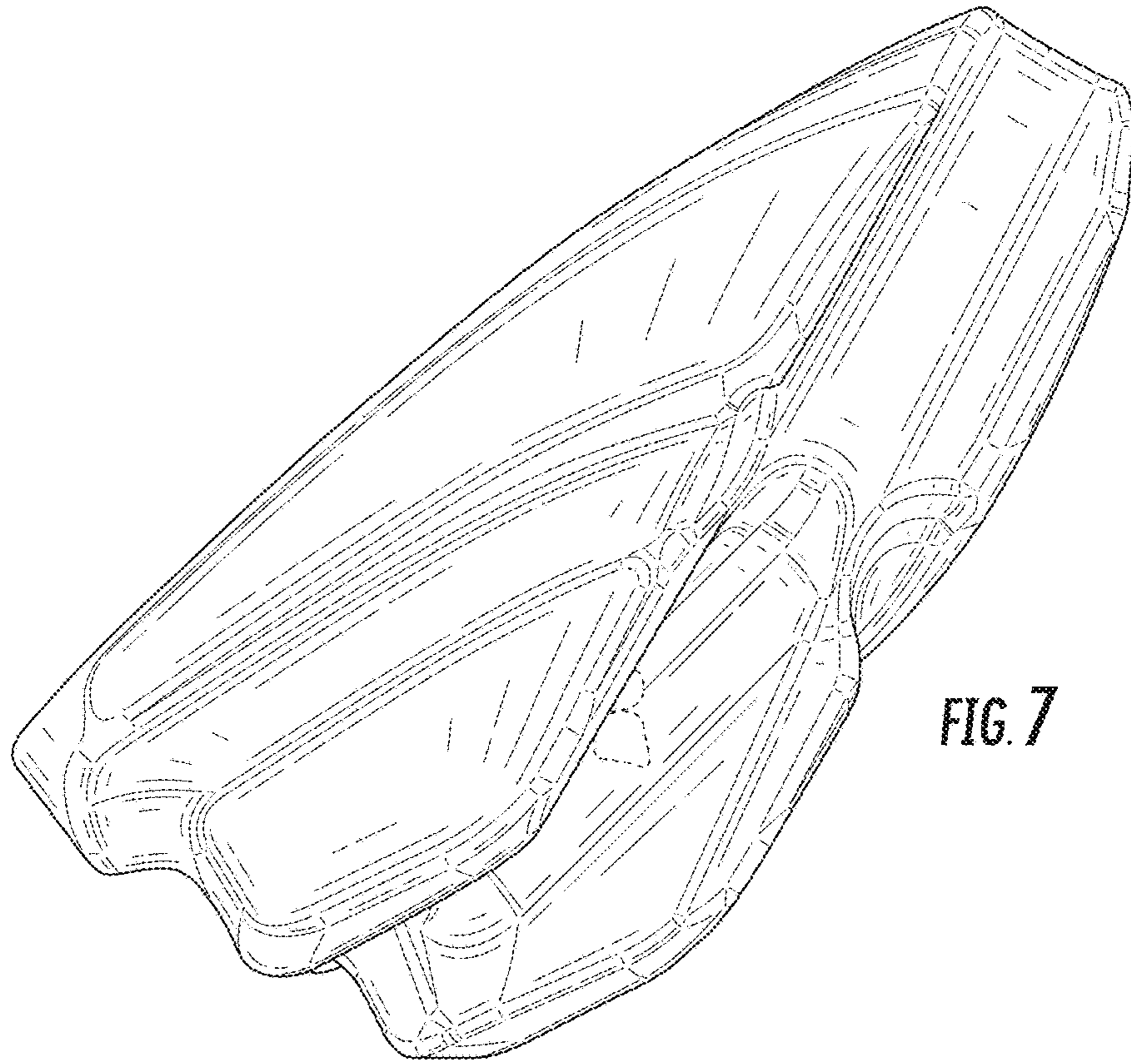

FIG. 6



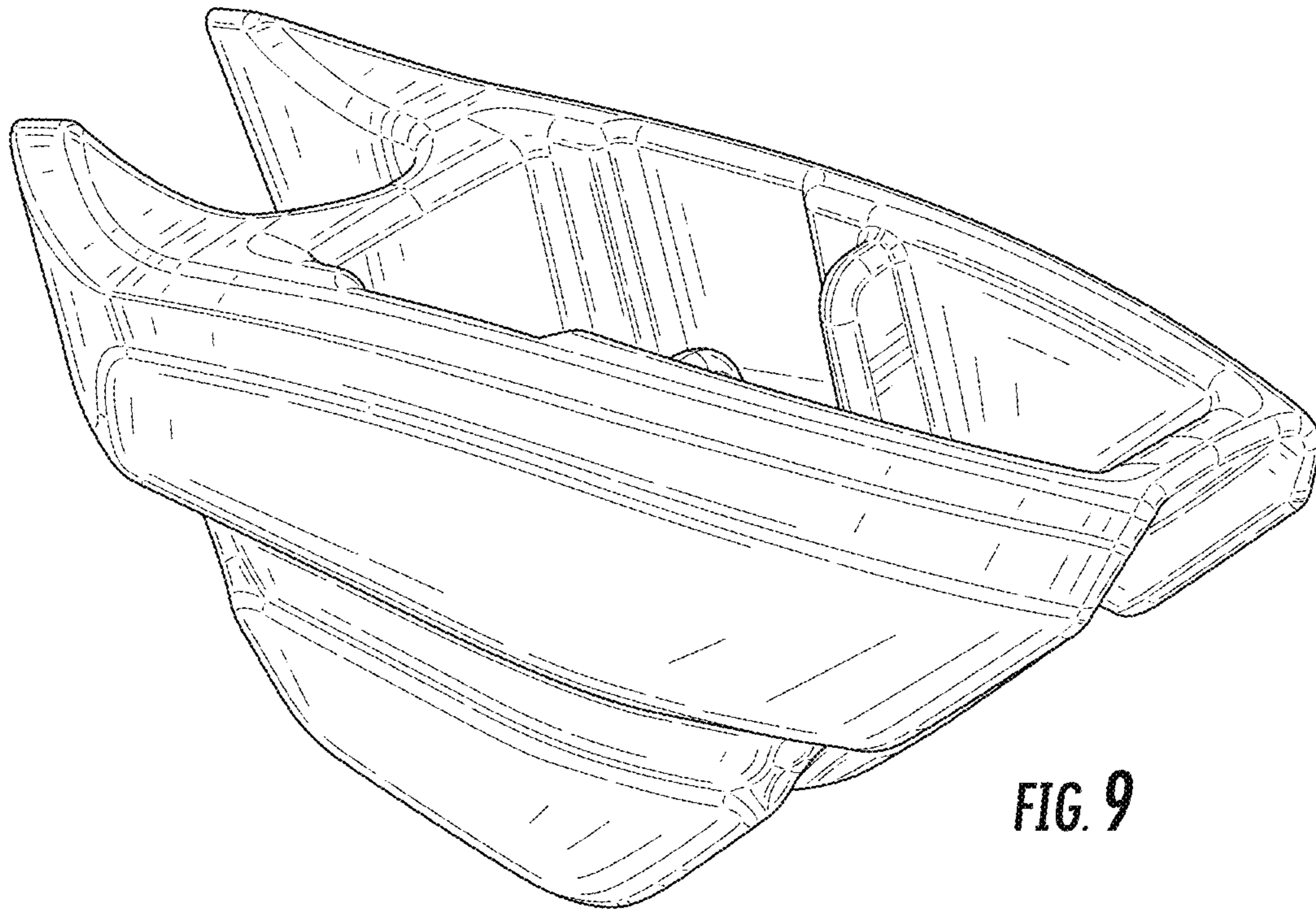

FIG. 9

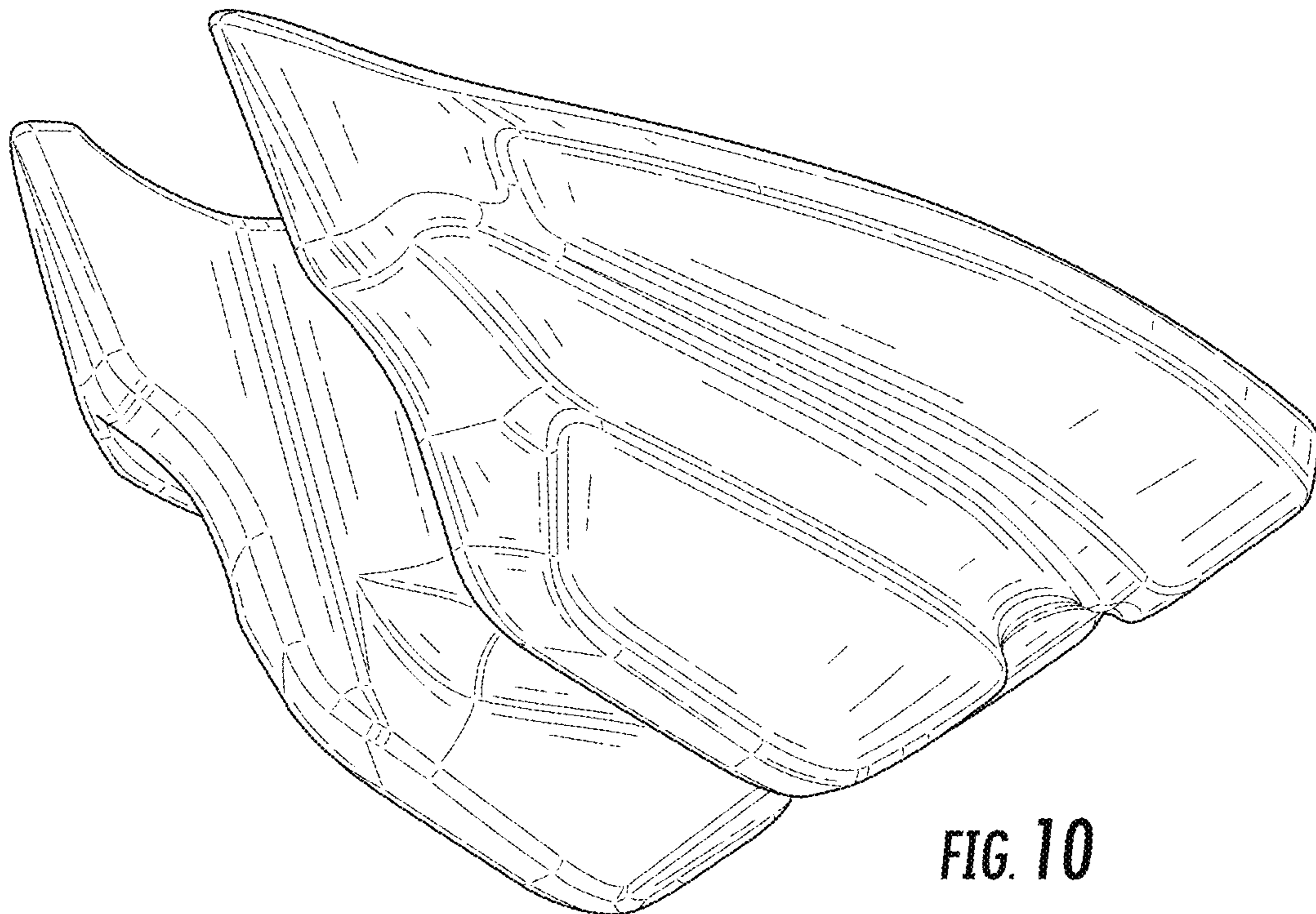

FIG. 10