



US00D774957S

(12) **United States Design Patent** (10) **Patent No.:** **US D774,957 S**
Umemoto (45) **Date of Patent:** **** Dec. 27, 2016**

(54) **ALL-TERRAIN VEHICLE**
(71) Applicant: **Yamaha Hatsudoki Kabushiki Kaisha,**
Shizuoka-ken (JP)
(72) Inventor: **Takeshi Umemoto,** Tokyo-to (JP)
(73) Assignee: **YAMAHA HATSUDOKI**
KABUSHIKI KAISHA (JP)
(**) Term: **14 Years**

D520,914 S * 5/2006 Luh D12/107
D522,924 S * 6/2006 Yokoyama D12/107
D539,705 S * 4/2007 Ichikawa D12/107
D546,246 S * 7/2007 Crepeau D12/107
D585,792 S * 2/2009 Chao D12/107
7,743,864 B2 * 6/2010 Tweet B60N 2/24
180/312
D620,399 S * 7/2010 Wu D12/107
D628,520 S * 12/2010 Lin D12/107
D643,781 S * 8/2011 Nagao D12/107
D680,468 S * 4/2013 Li D12/107
2008/0277184 A1 * 11/2008 Marleau B62K 5/01
180/312

(21) Appl. No.: **29/517,390**
(22) Filed: **Feb. 12, 2015**
(51) **LOC (10) Cl.** **12-11**
(52) **U.S. Cl.**
USPC **D12/107**
(58) **Field of Classification Search**
USPC D12/3, 4, 5, 14, 85, 86, 87, 107, 110;
280/183–185, DIG. 5, 1, 16, 82, 88, 90,
280/14; 180/233, 908
CPC A01B 59/02; A61G 3/08; B62B 5/04;
B62B 13/10; B62B 19/04; B62B
2202/404; B62C 9/00; B62D 7/22; B62K
5/01; B60K 23/0808
See application file for complete search history.

* cited by examiner

Primary Examiner — Darlington Ly
(74) *Attorney, Agent, or Firm* — Ostrolenk Faber LLP

(57) **CLAIM**

I claim the ornamental design for an all-terrain vehicle, as shown and described.

DESCRIPTION

FIG. 1 is a top, front, and right side perspective view of an all-terrain vehicle;
FIG. 2 is a top, rear and left side perspective view thereof;
FIG. 3 is a front elevational view thereof;
FIG. 4 is a rear elevational view thereof;
FIG. 5 is a left side elevational view thereof;
FIG. 6 is a right side elevational view thereof; and,
FIG. 7 is a top plan view thereof.

(56) **References Cited**
U.S. PATENT DOCUMENTS
D374,416 S * 10/1996 Miyamoto D12/107
D513,718 S * 1/2006 Itaya D12/107

1 Claim, 7 Drawing Sheets

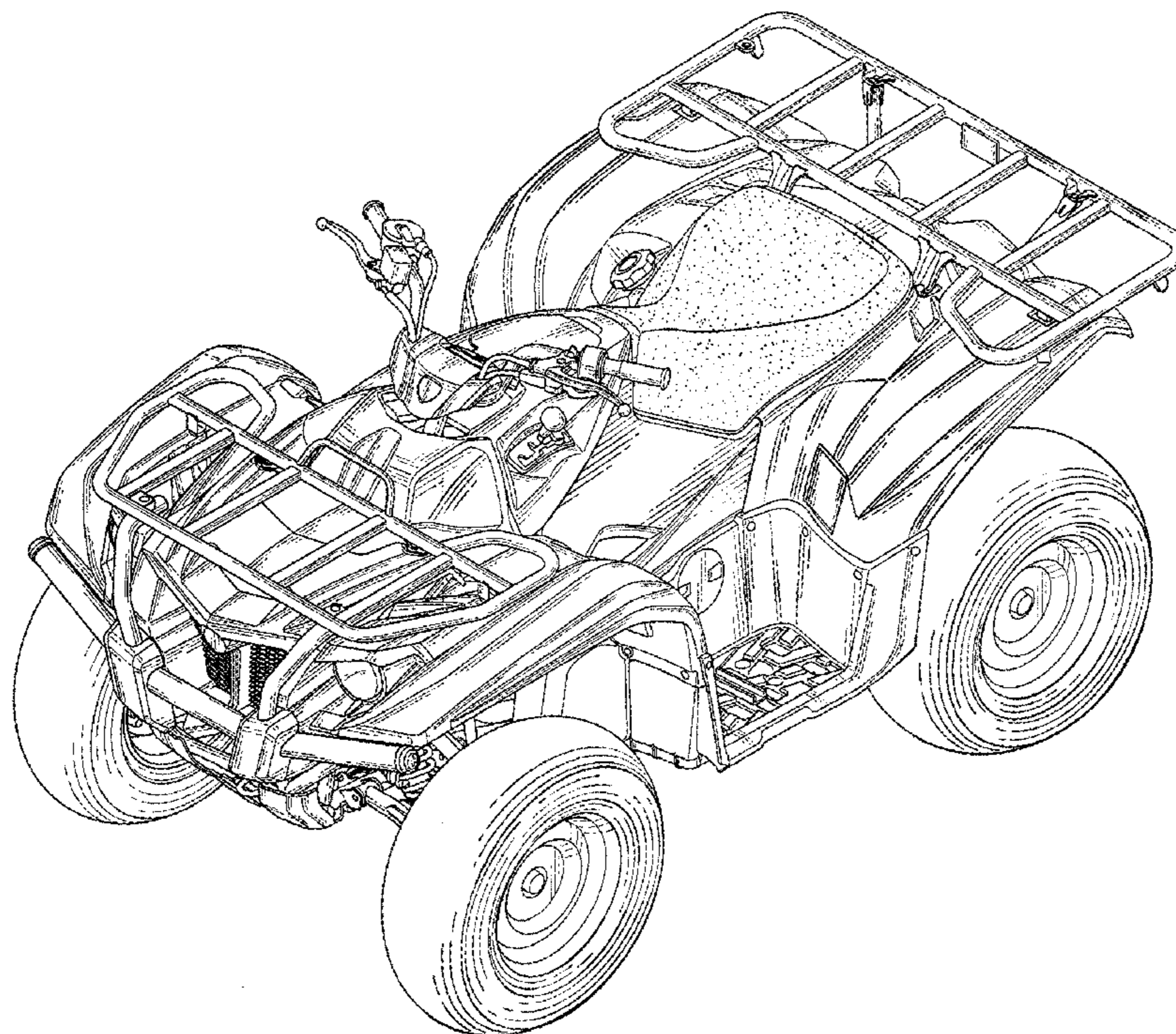

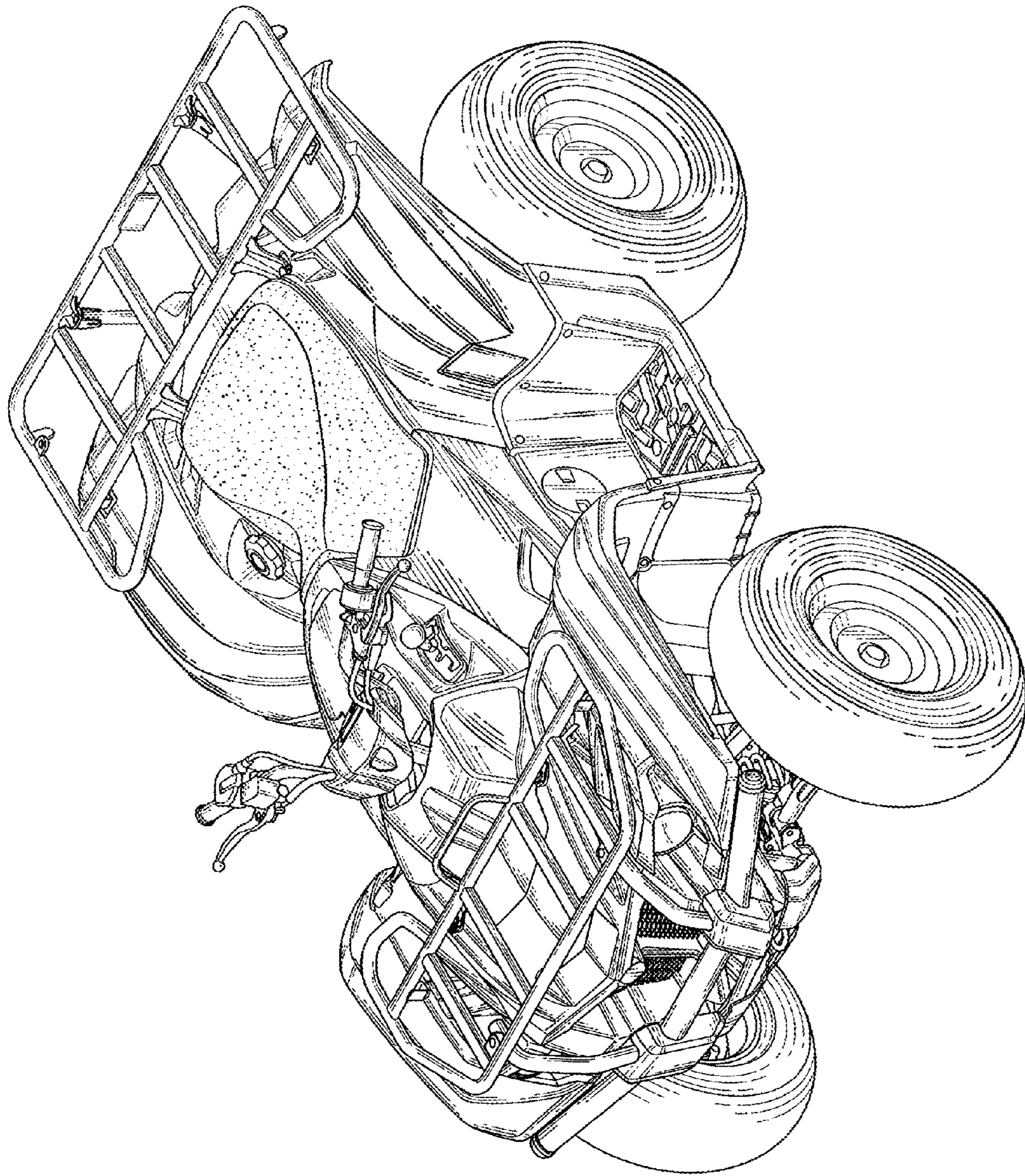
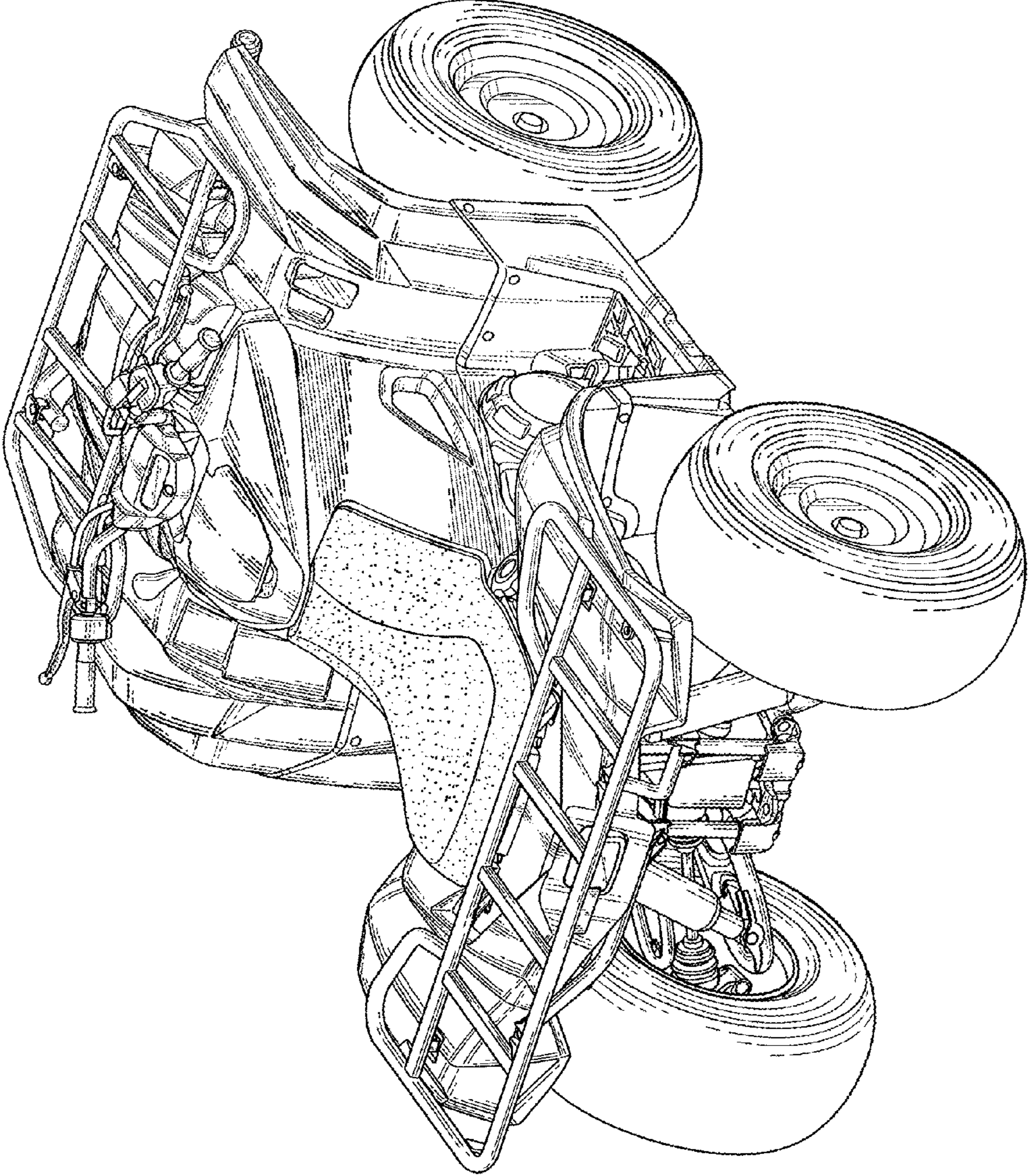

Fig. 1

Fig. 2



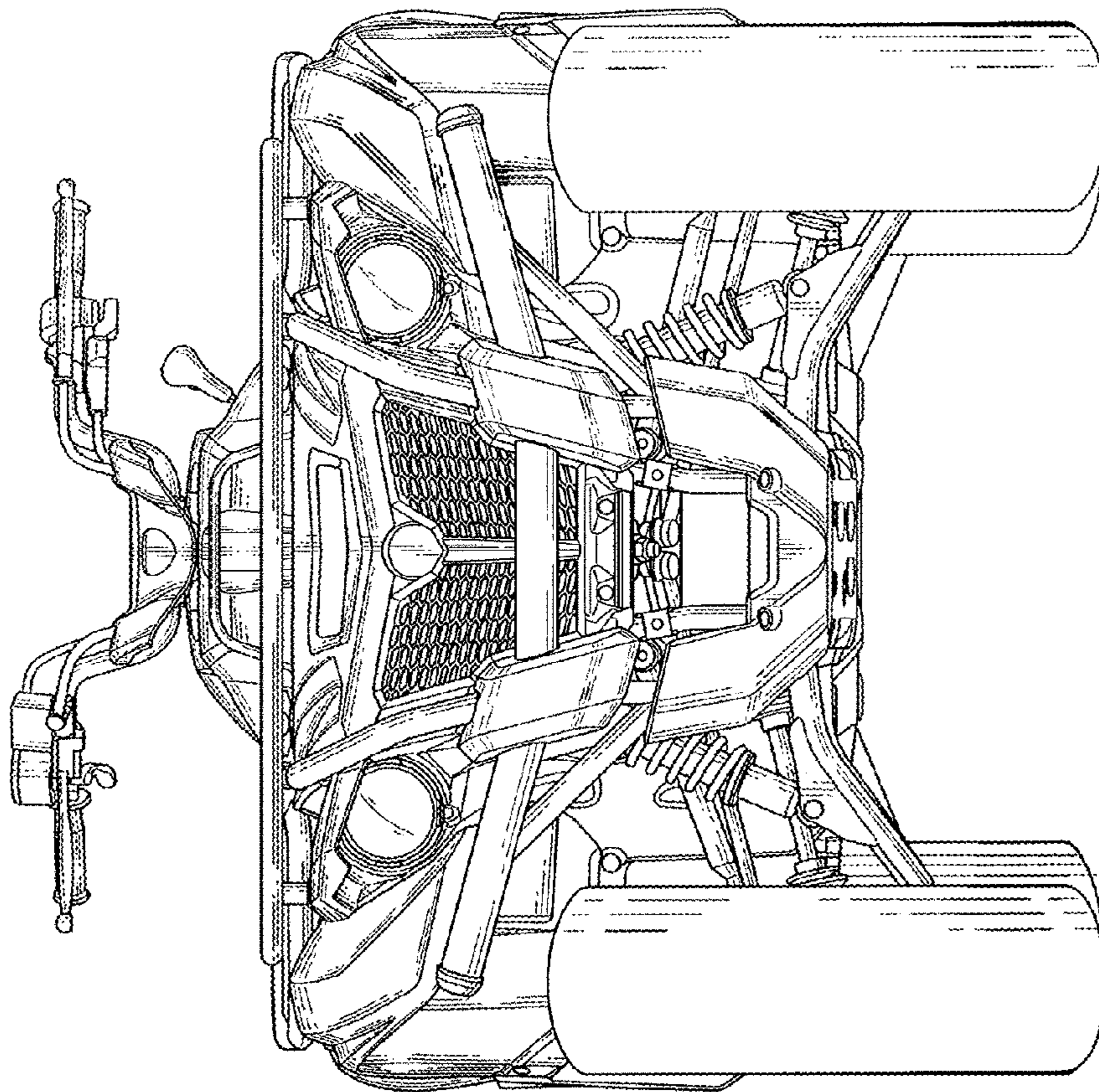

Fig. 3

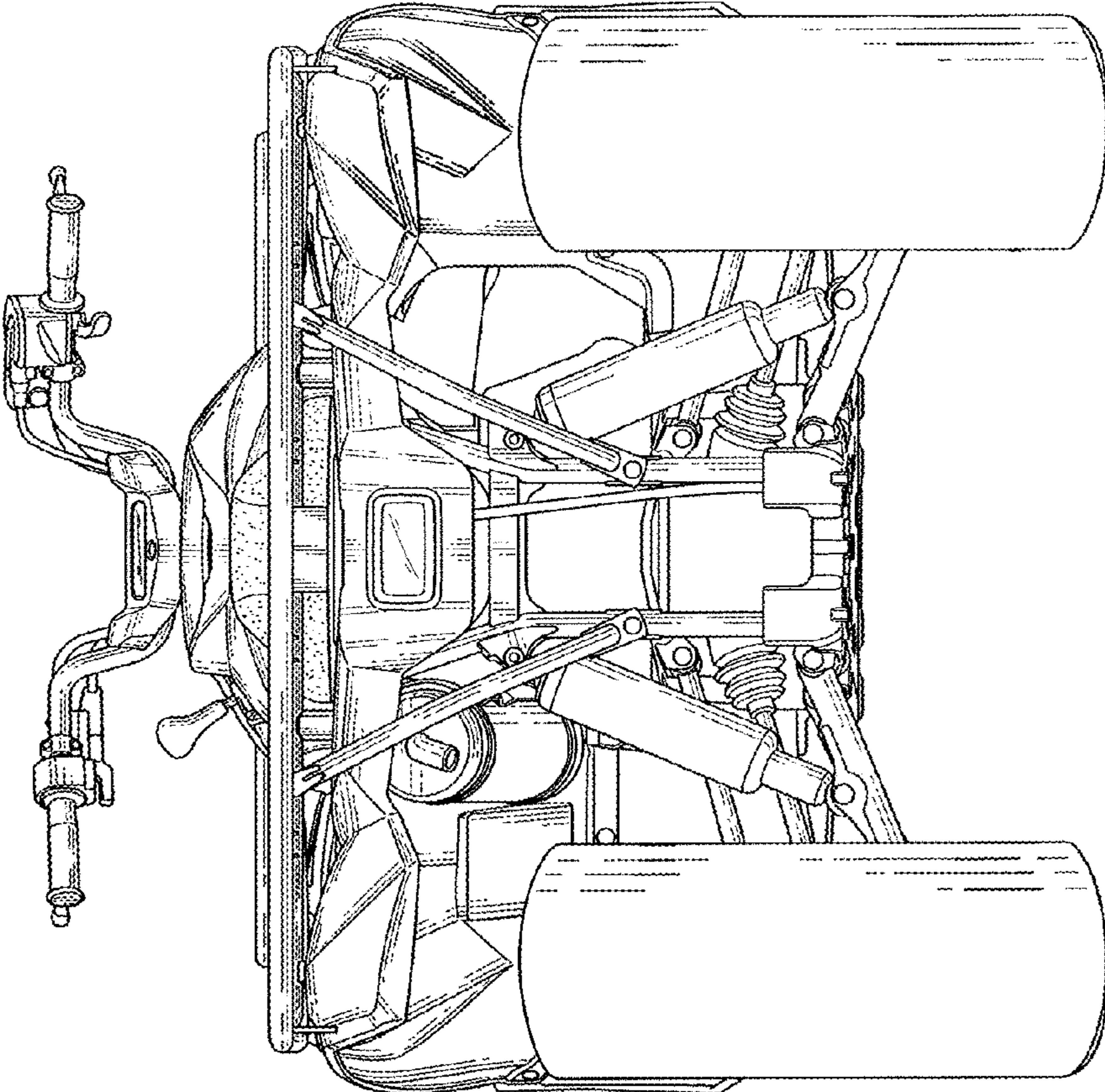

Fig. 4

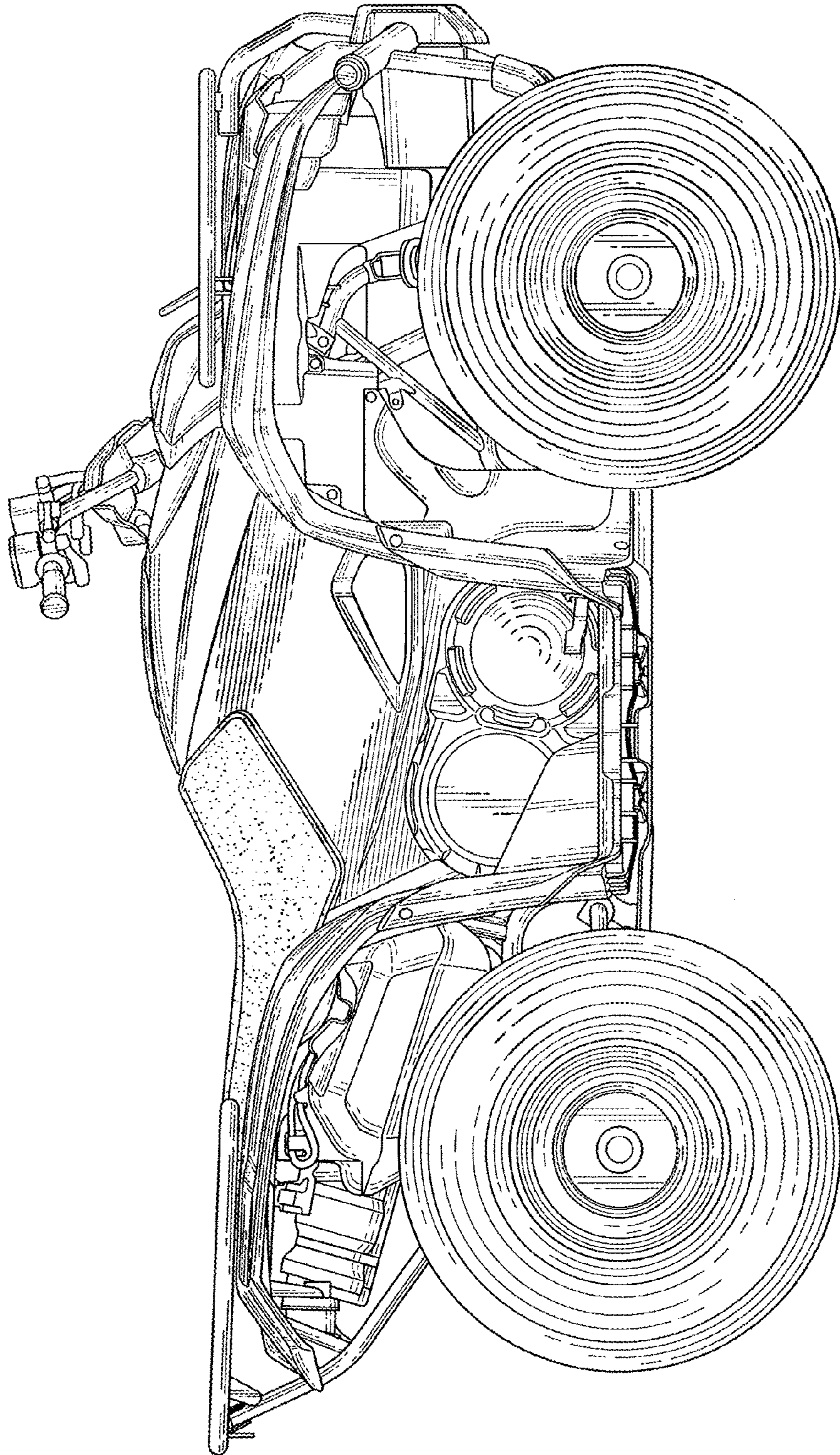

Fig. 5

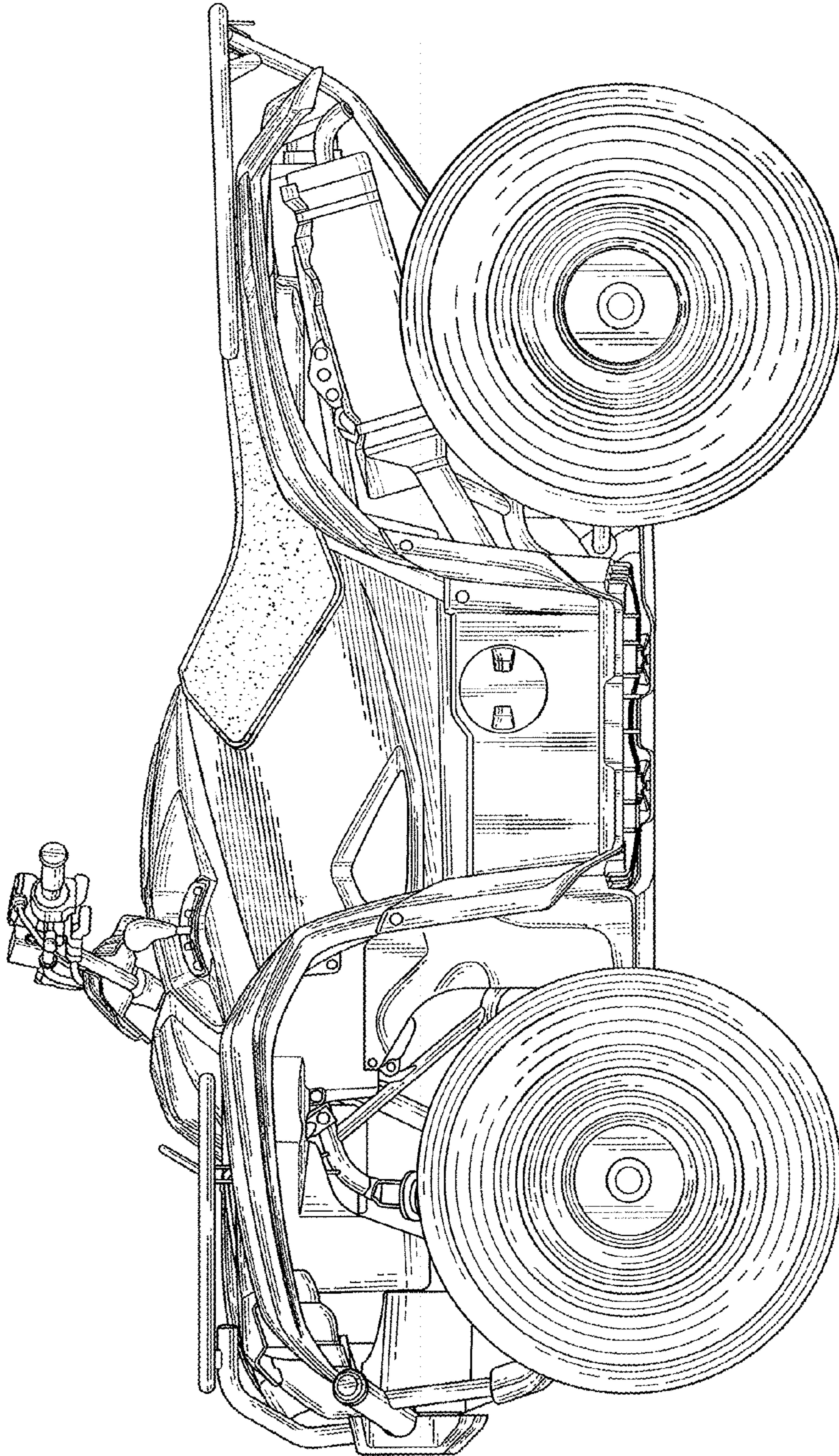

Fig. 6

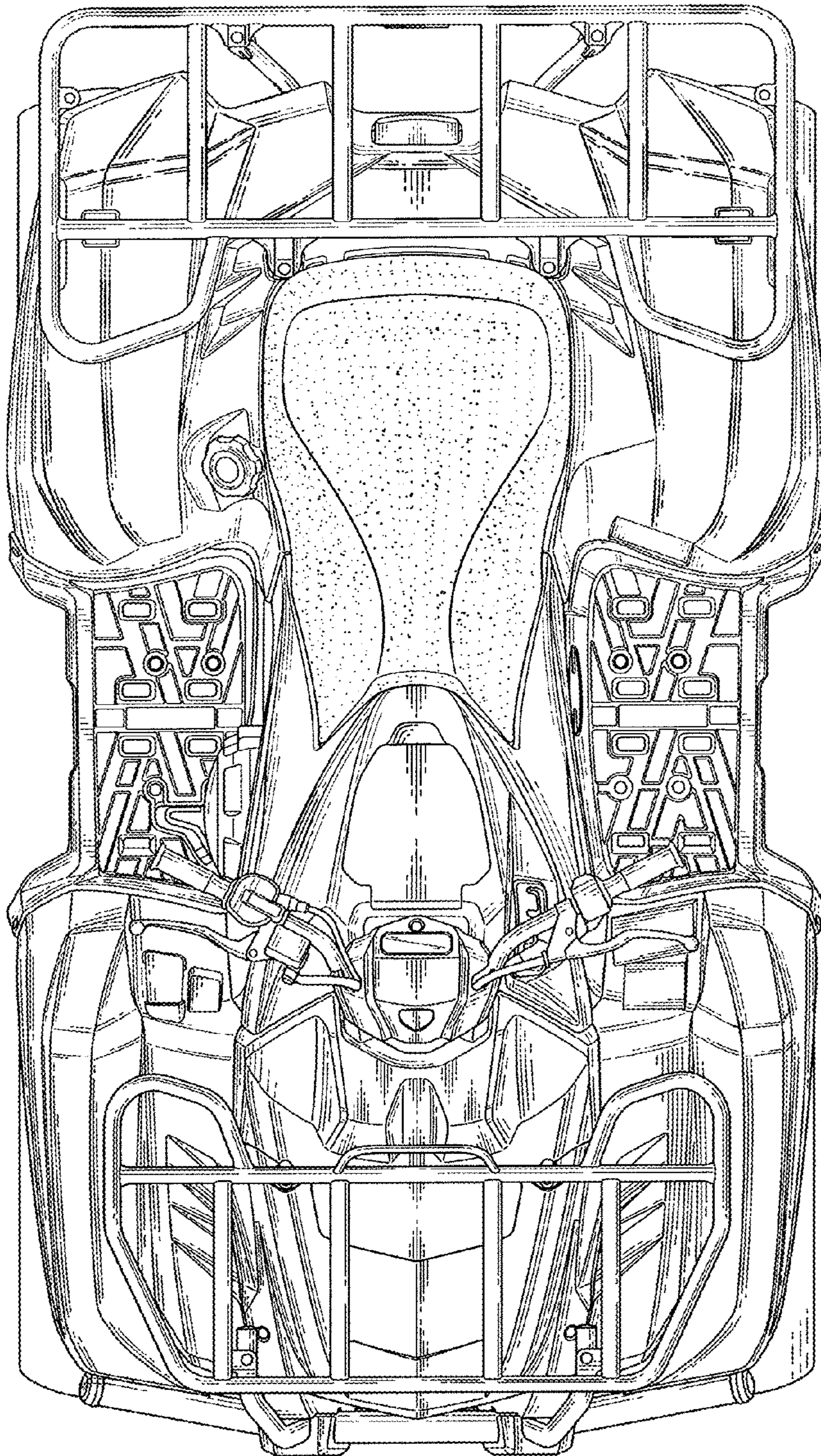

Fig. 7