



US00D774956S

(12) **United States Design Patent**
Tanaka

(10) **Patent No.:** **US D774,956 S**

(45) **Date of Patent:** **** Dec. 27, 2016**

(54) **AUTO-UNICYCLE WITH A SAFETY WHEEL**

(71) Applicant: **Honda Motor Co., Ltd.**, Tokyo (JP)

(72) Inventor: **Takehisa Tanaka**, Wako (JP)

(73) Assignee: **Honda Motor Co., Ltd.**, Tokyo (JP)

(**) Term: **14 Years**

(21) Appl. No.: **29/487,389**

(22) Filed: **Apr. 8, 2014**

(30) **Foreign Application Priority Data**

Oct. 18, 2013 (JP) 2013-024240

(51) **LOC (10) Cl.** **12-11**

(52) **U.S. Cl.**
USPC **D12/107**

(58) **Field of Classification Search**
USPC D12/1, 107, 110; 180/7.1, 11, 13, 20, 21,
180/65.1, 65.51, 205.1–205.7, 313;
280/205

(Continued)

(56) **References Cited**

U.S. PATENT DOCUMENTS

D217,175 S * 4/1970 Swanberg D12/107
5,002,295 A * 3/1991 Lin 280/205

(Continued)

OTHER PUBLICATIONS

Lai, Richard. "Honda's latest robotic stool is fun to ride, still impossible to buy." Engadget., Oct. 10, 2014 [online], [retrieved on Aug. 6, 2015]. Retrieved from the Internet <URL: <http://www.engadget.com/2014/10/10/honda-uni-cub-beta-ceatec-2014/>>.*

(Continued)

Primary Examiner — Darlington Ly

(74) *Attorney, Agent, or Firm* — Plumsea Law Group, LLC

(57) **CLAIM**

The ornamental design for an auto-unicycle with a safety wheel, as shown and described.

DESCRIPTION

FIG. 1 is a front and right-side perspective view of an auto-unicycle with a safety wheel;
FIG. 2 is a rear and right-side perspective view thereof;
FIG. 3 is a front and left-side perspective view thereof;
FIG. 4 is a rear and left-side perspective view thereof;
FIG. 5 is a front elevation view thereof.
FIG. 6 is a rear elevation view thereof.
FIG. 7 is a left side elevation view thereof.
FIG. 8 is a right side elevation view thereof.
FIG. 9 is a top plan view thereof.
FIG. 10 is a bottom plan view thereof.
FIG. 11 is a front and right-side perspective view thereof with the pedals folded away;
FIG. 12 is a rear and right-side perspective view thereof with the pedals folded away;
FIG. 13 is a front and left-side perspective view thereof with the pedals folded away;
FIG. 14 is a rear and left-side perspective view thereof with the pedals folded away;
FIG. 15 is a front elevation view with the pedals folded away.
FIG. 16 is a front perspective view showing use thereof; and,
FIG. 17 is a rear perspective view showing use thereof.
The broken lines in the drawings illustrate portions of the auto-unicycle with a safety wheel and environmental structure that forms no part of the claimed design.

1 Claim, 17 Drawing Sheets

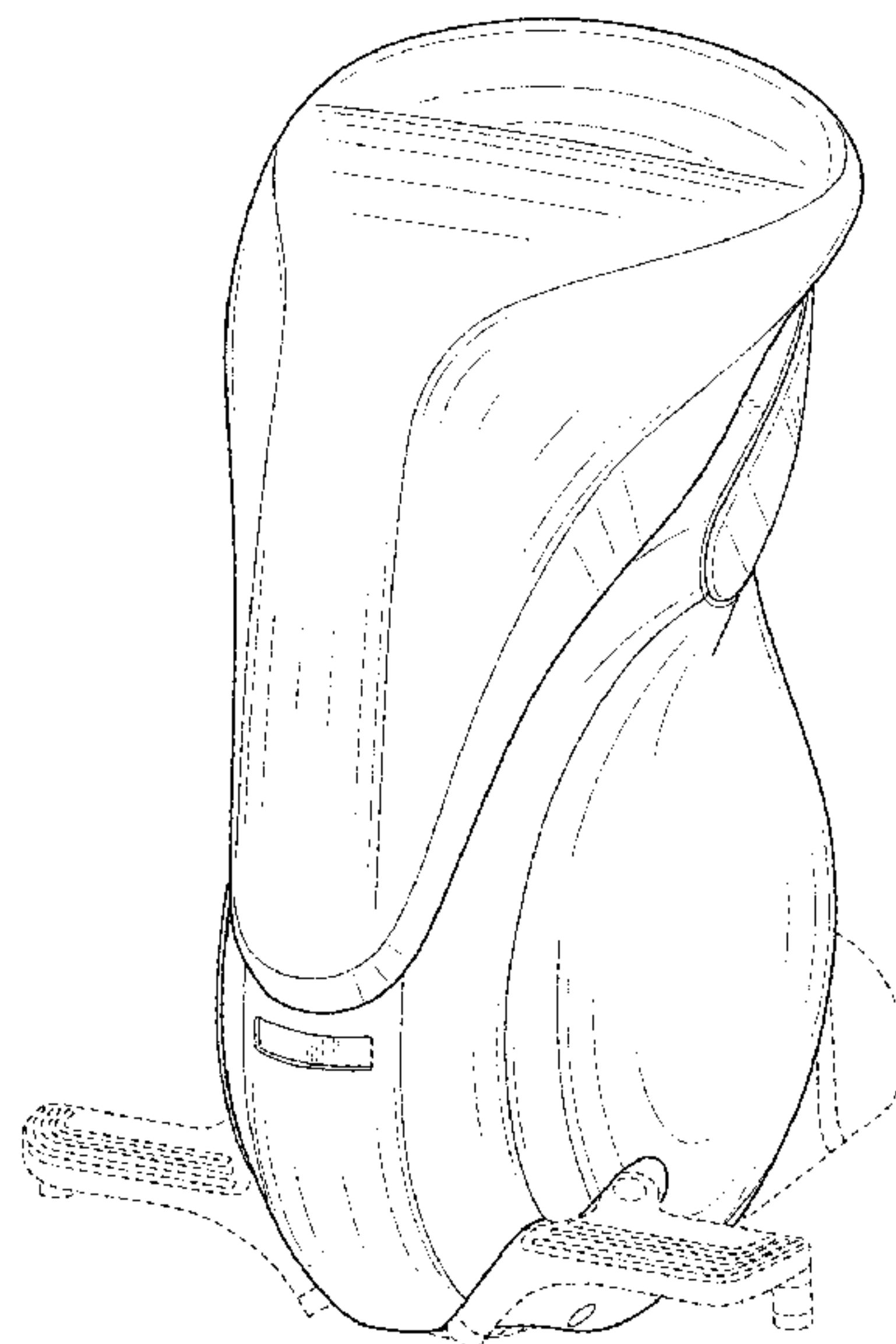

(58) **Field of Classification Search**

CPC B62D 61/00; B62K 1/00; B62K 3/007
See application file for complete search history.

(56) **References Cited**

U.S. PATENT DOCUMENTS

D324,252	S *	2/1992	Williamson	D21/763
D505,363	S *	5/2005	Aube et al.	D12/107
D626,892	S *	11/2010	Shin	D12/107
D685,295	S *	7/2013	Mori et al.	D12/107
2011/0056757	A1 *	3/2011	Polutnik	180/65.51
2011/0070997	A1 *	3/2011	Gomi et al.	476/66
2011/0175319	A1 *	7/2011	Chen	280/205
2012/0172169	A1 *	7/2012	Gomi et al.	475/197
2012/0175176	A1 *	7/2012	Hamaya et al.	180/21
2012/0217072	A1 *	8/2012	Hoffmann et al.	180/21
2014/0196962	A1 *	7/2014	Hoffmann et al.	180/21

OTHER PUBLICATIONS

Lee, Kevin. "You Can Use Honda's Segway-Like Vehicle While Sitting: There Goes the Human Race." Tech Hive., May 16, 2012 [online], [retrieved on Aug. 6, 2015]. Retrieved from the Internet <URL: http://www.techhive.com/article/255702/you_can_use_hondas_segway_like_vehicle_while_sitting_there_goes_the_human_race.html>.*

* cited by examiner

FIG. 1

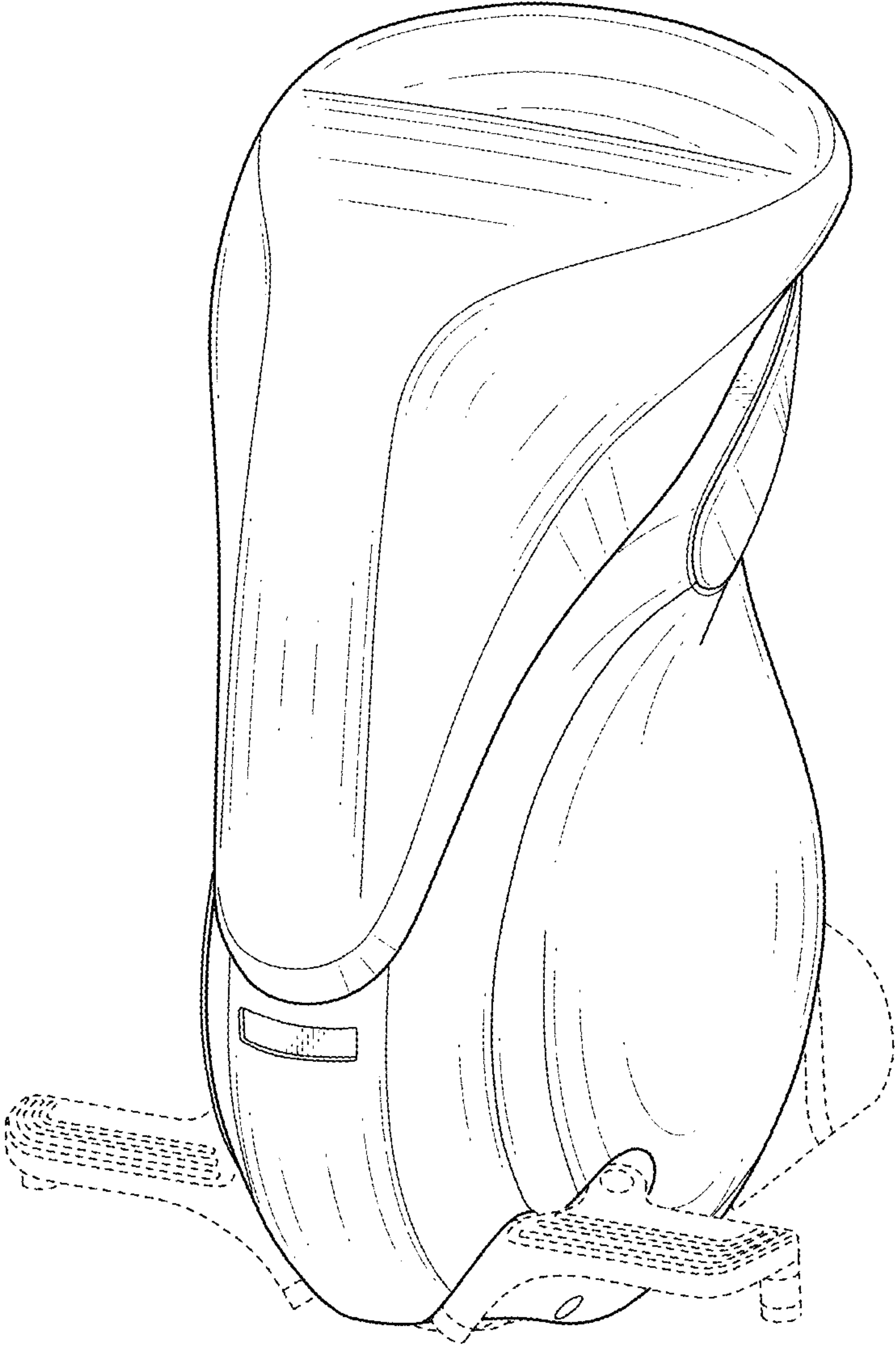

FIG. 2

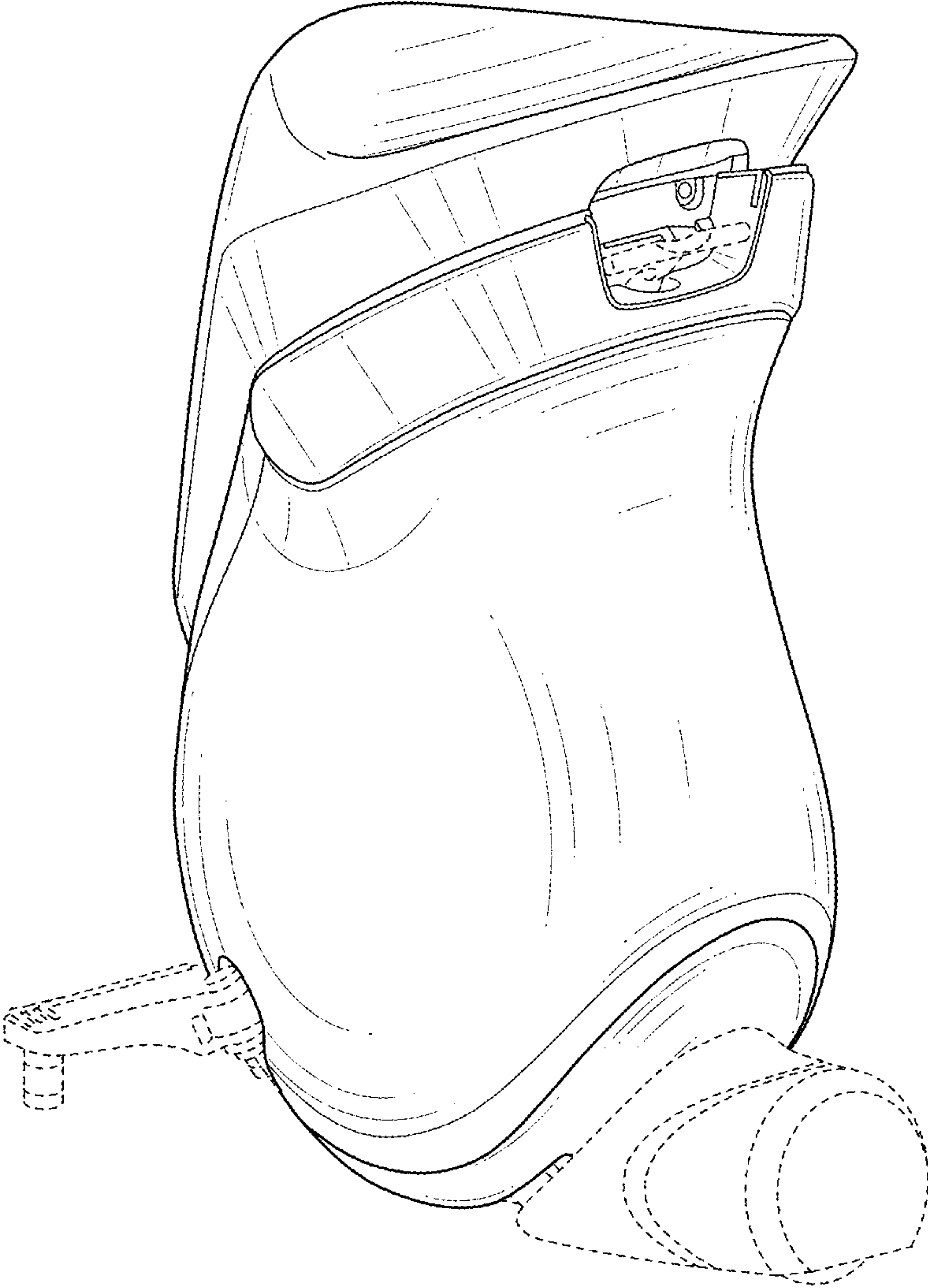

FIG. 3

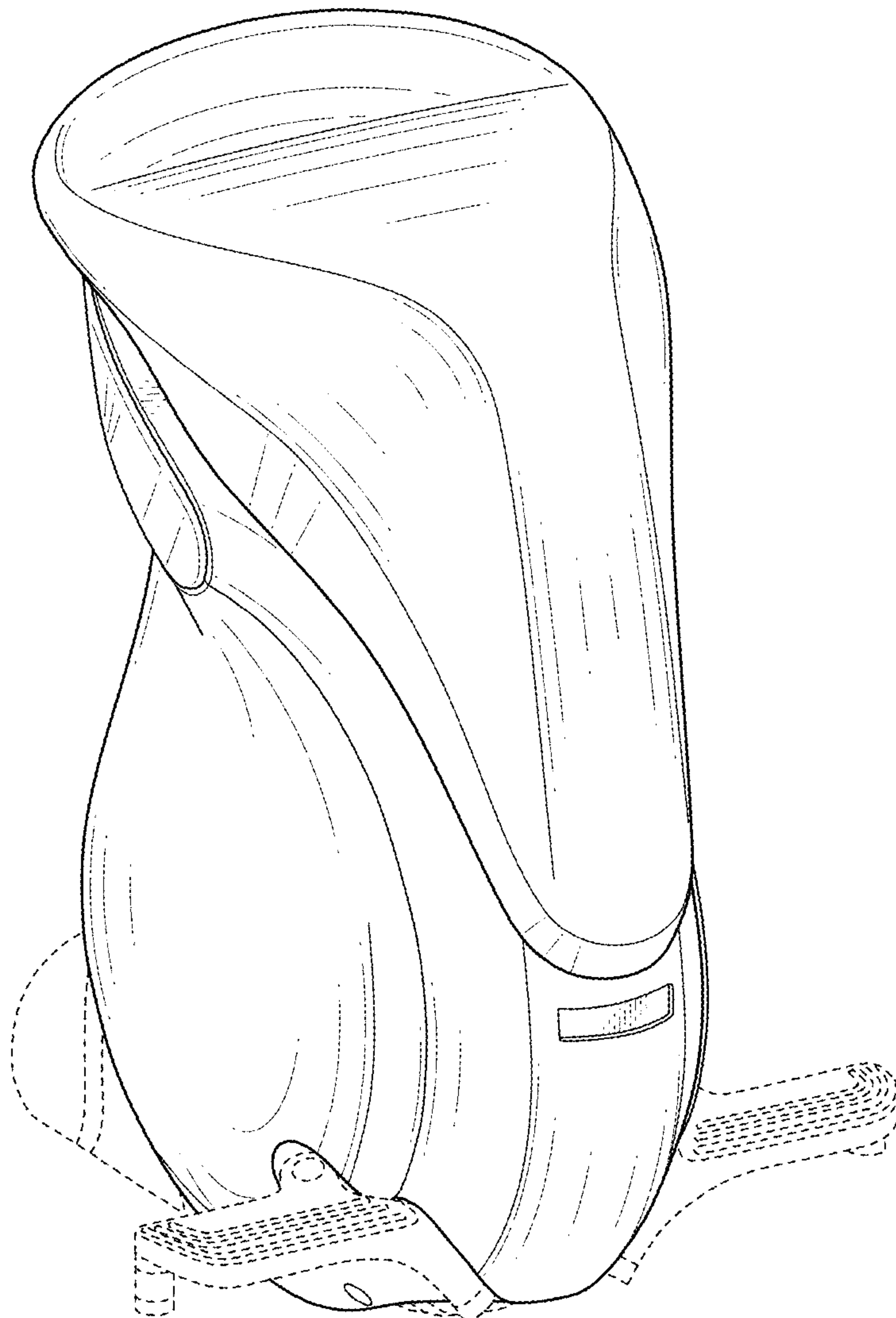

FIG. 4

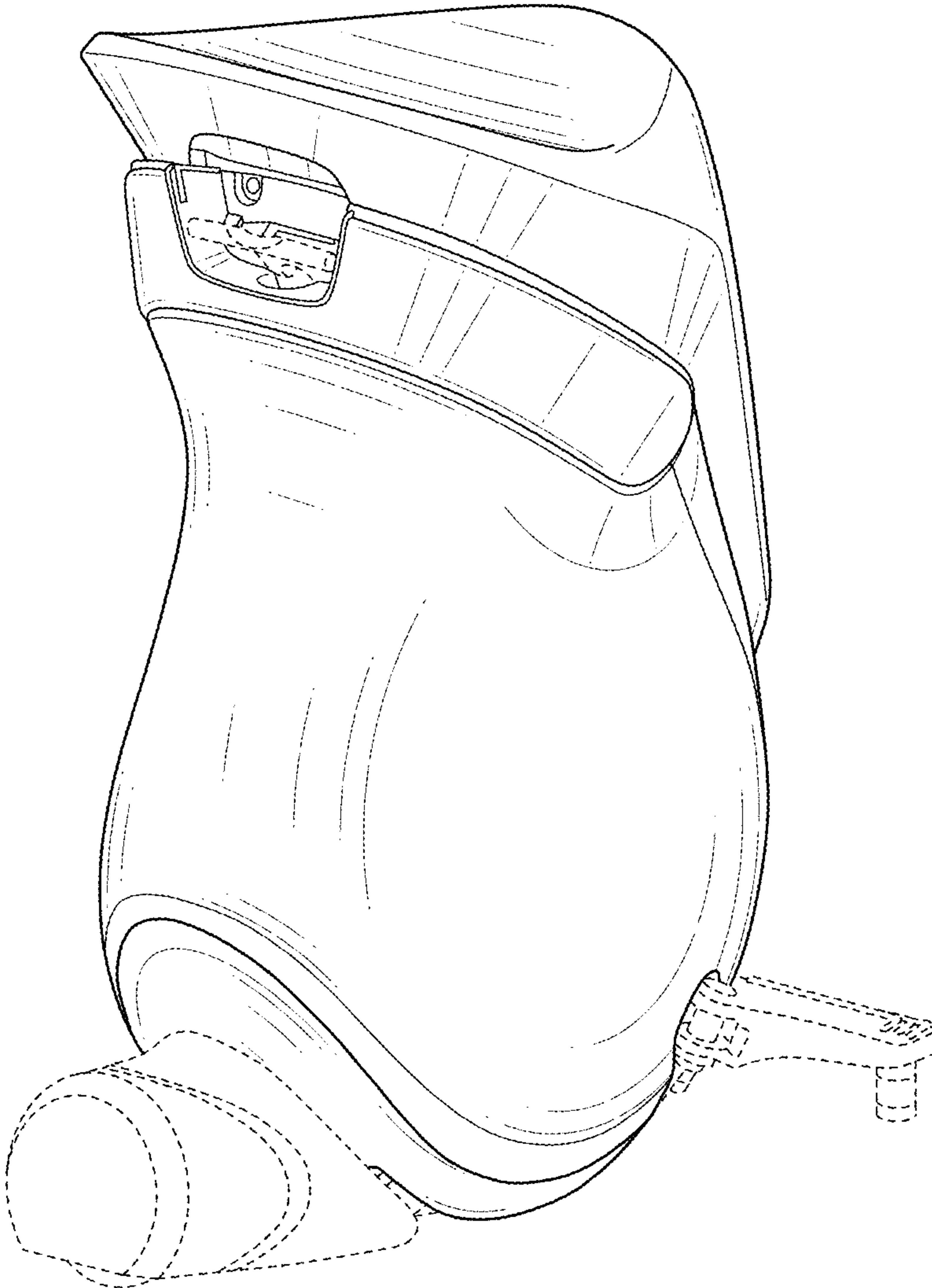

FIG. 5

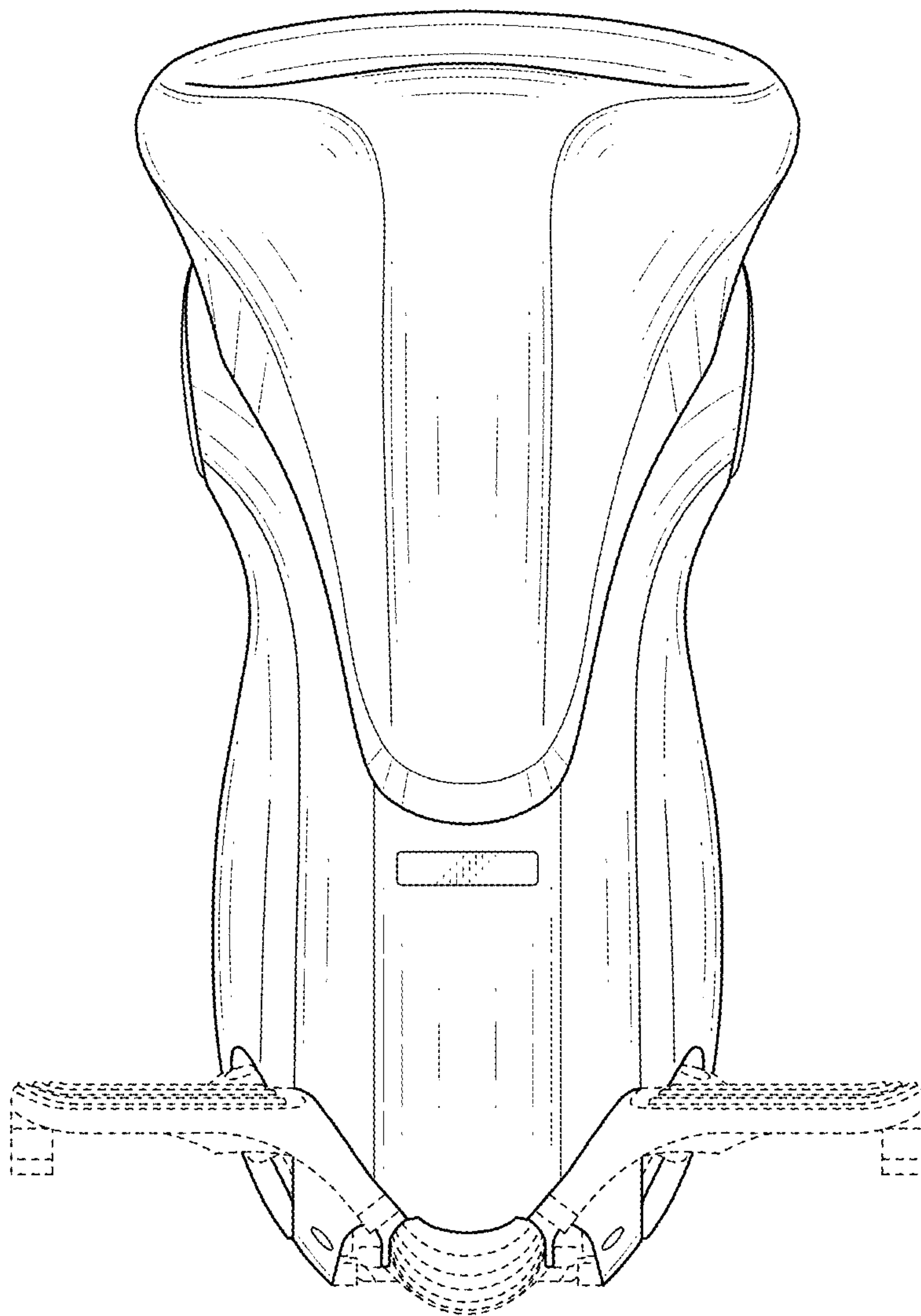

FIG. 6

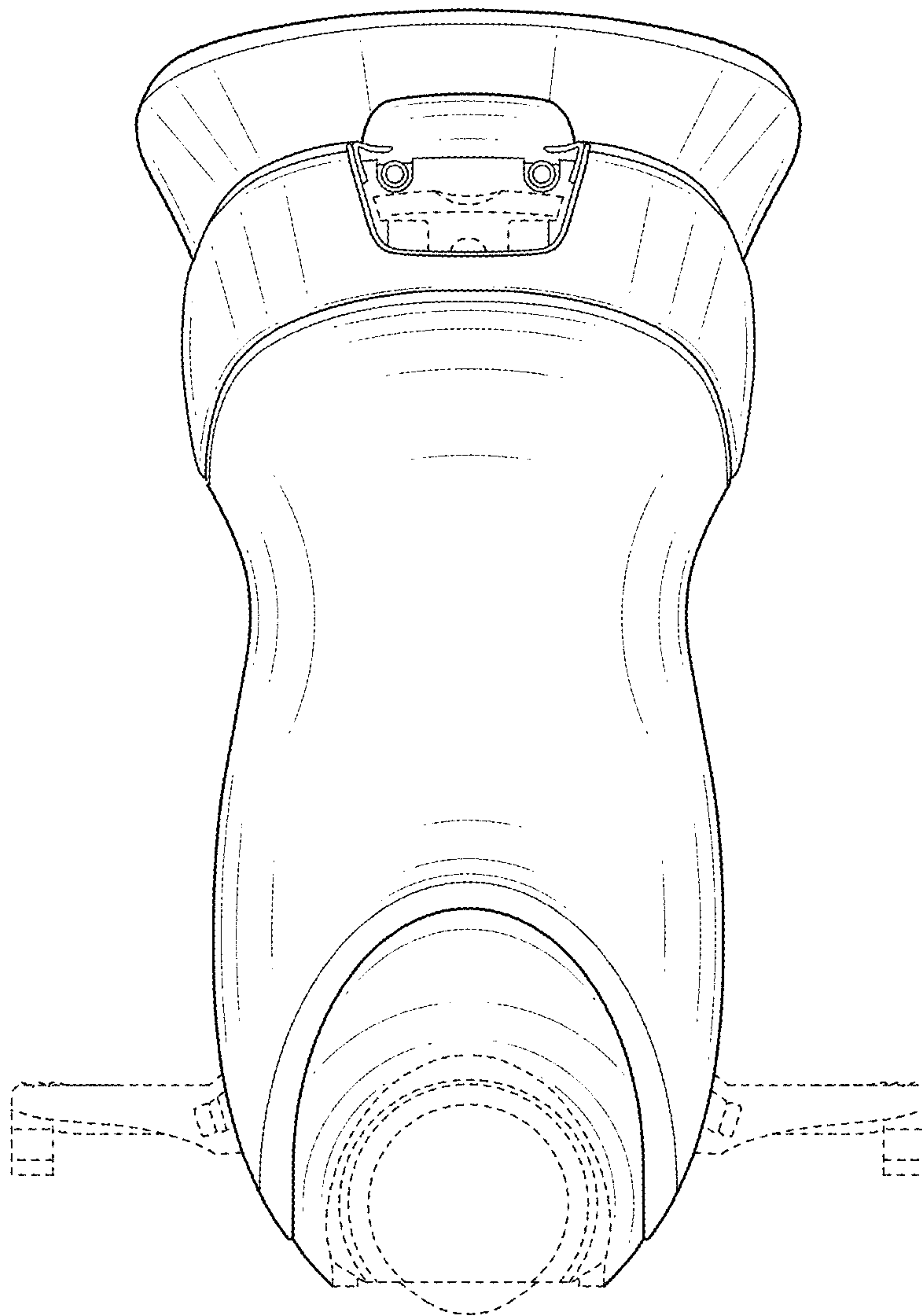

FIG. 7

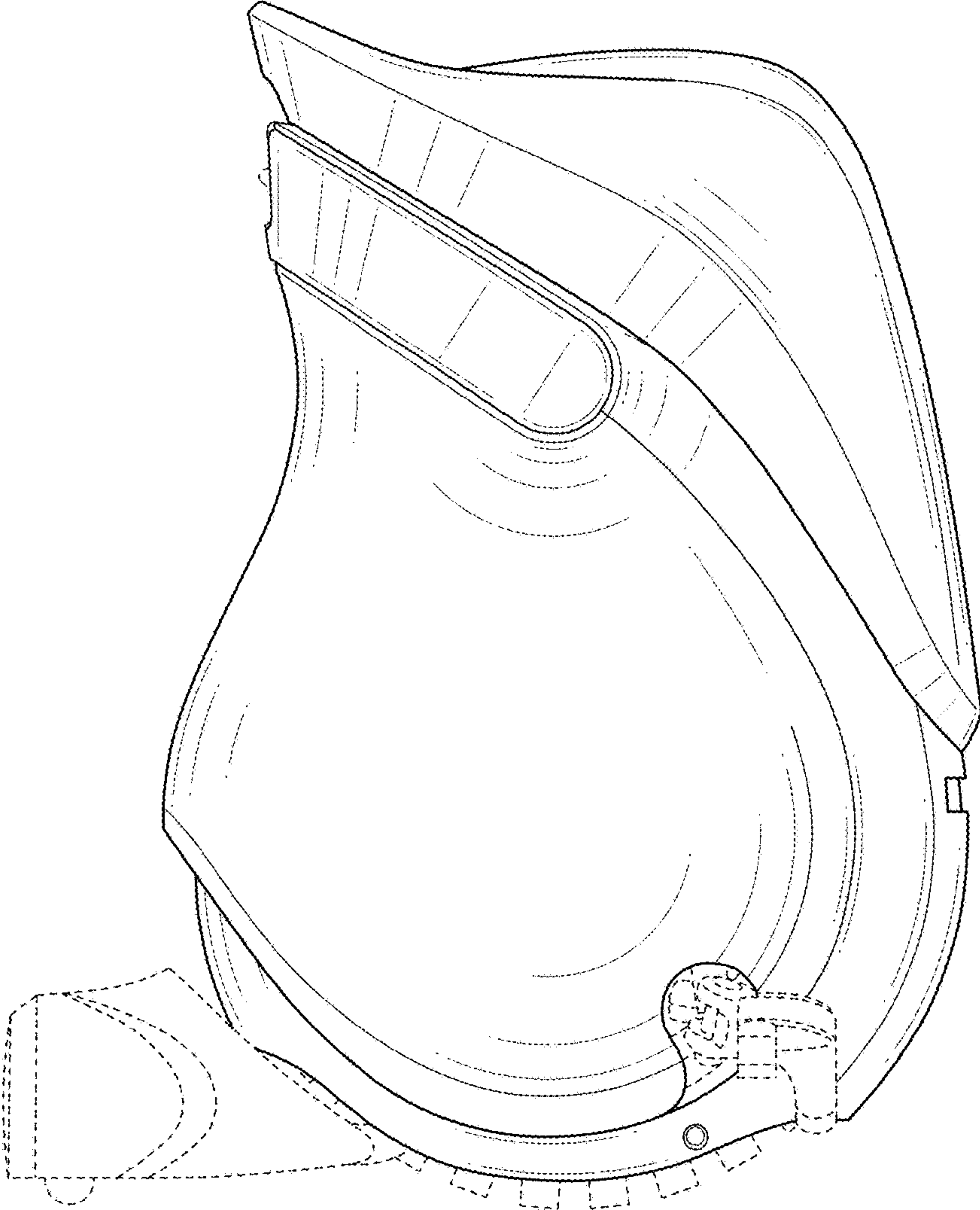

FIG. 8

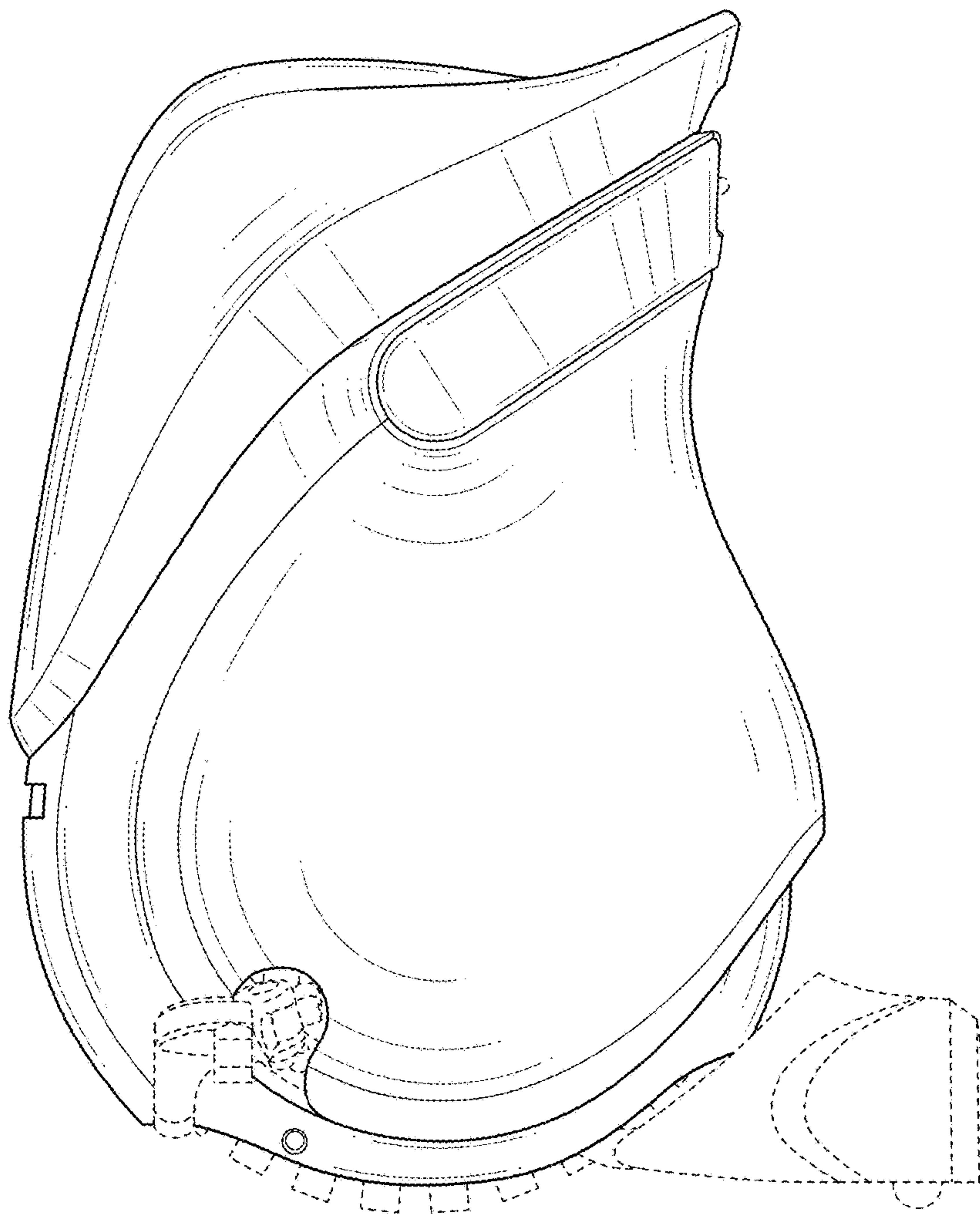

FIG. 9

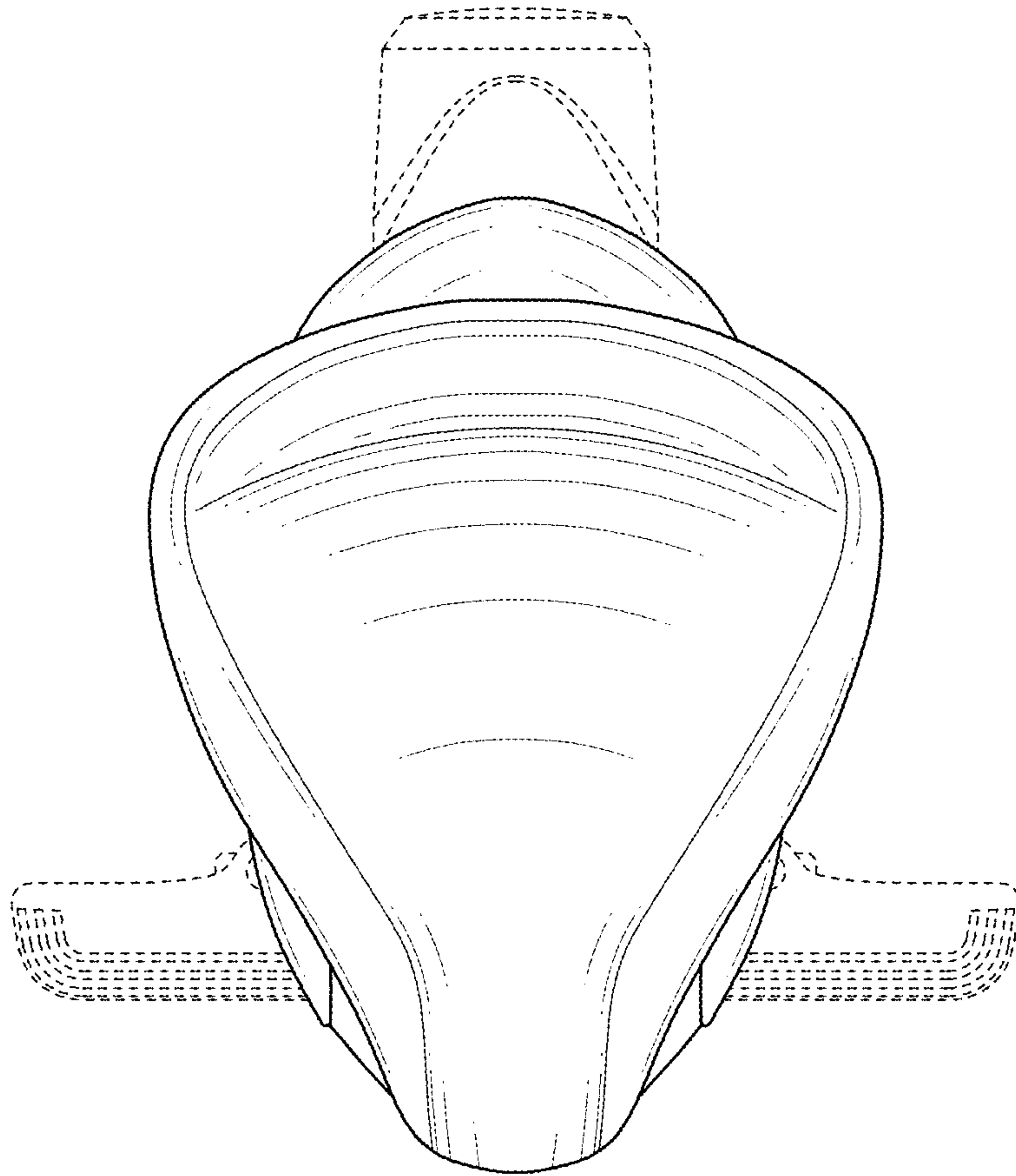

FIG. 10

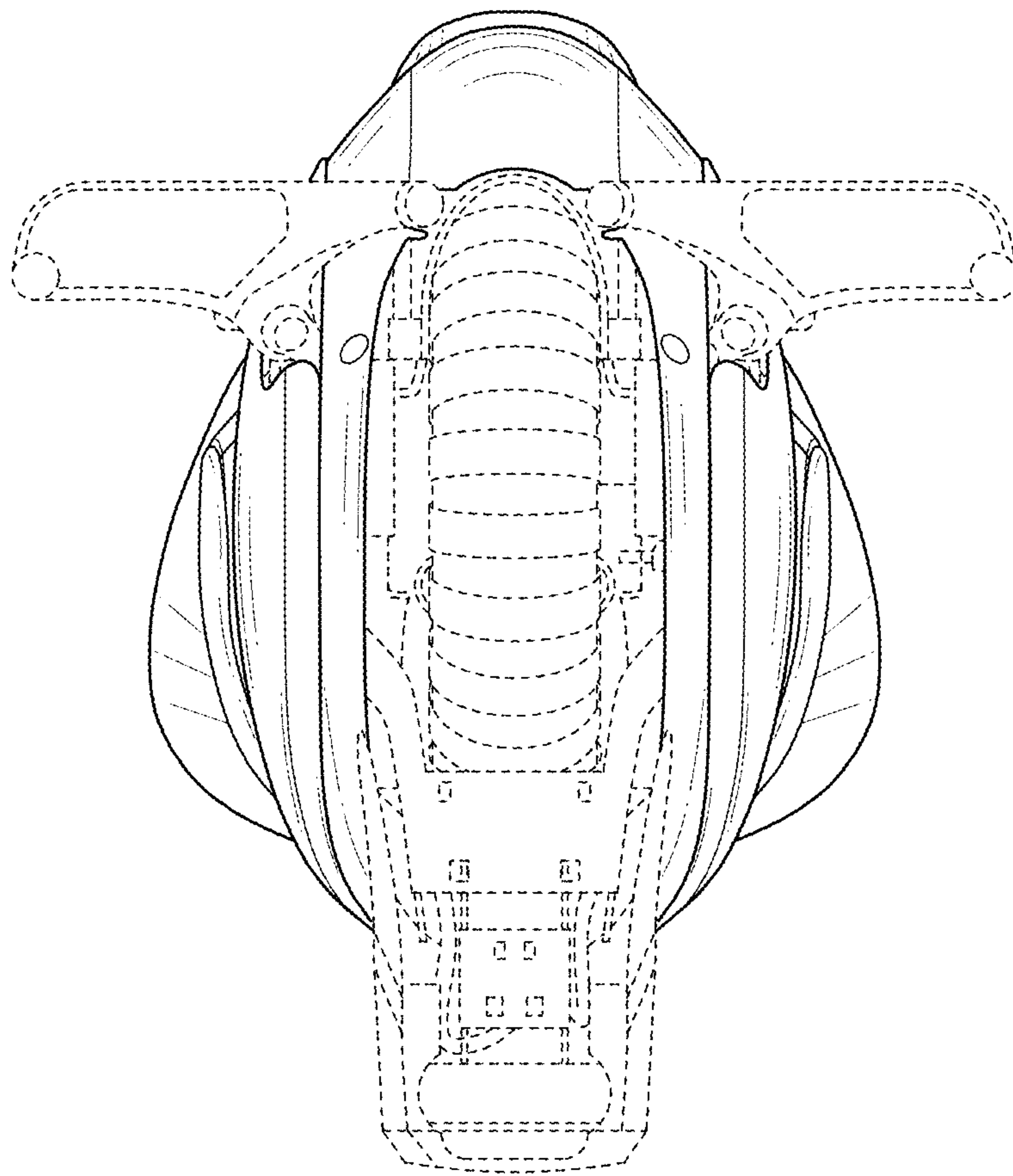

FIG. 11

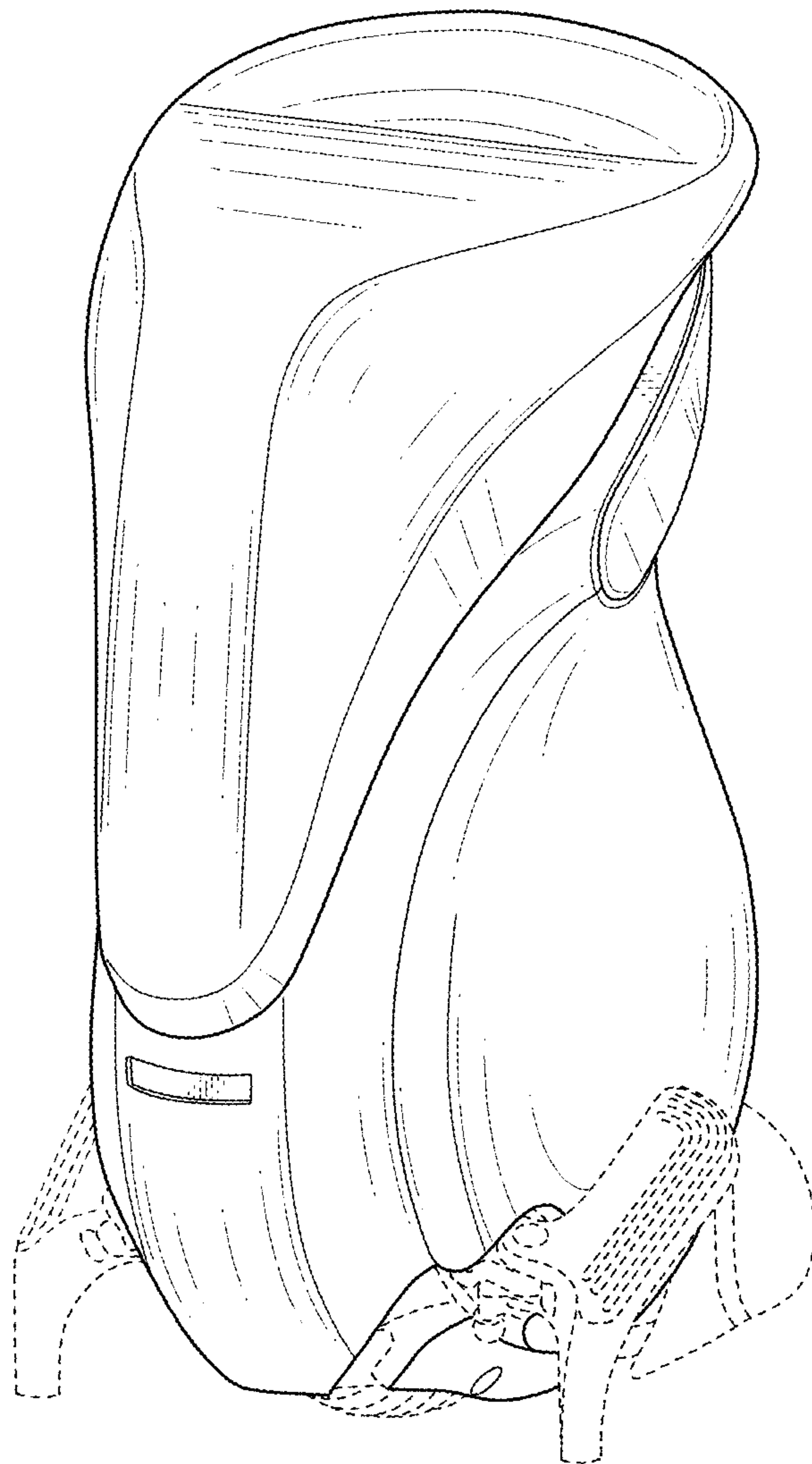

FIG. 12

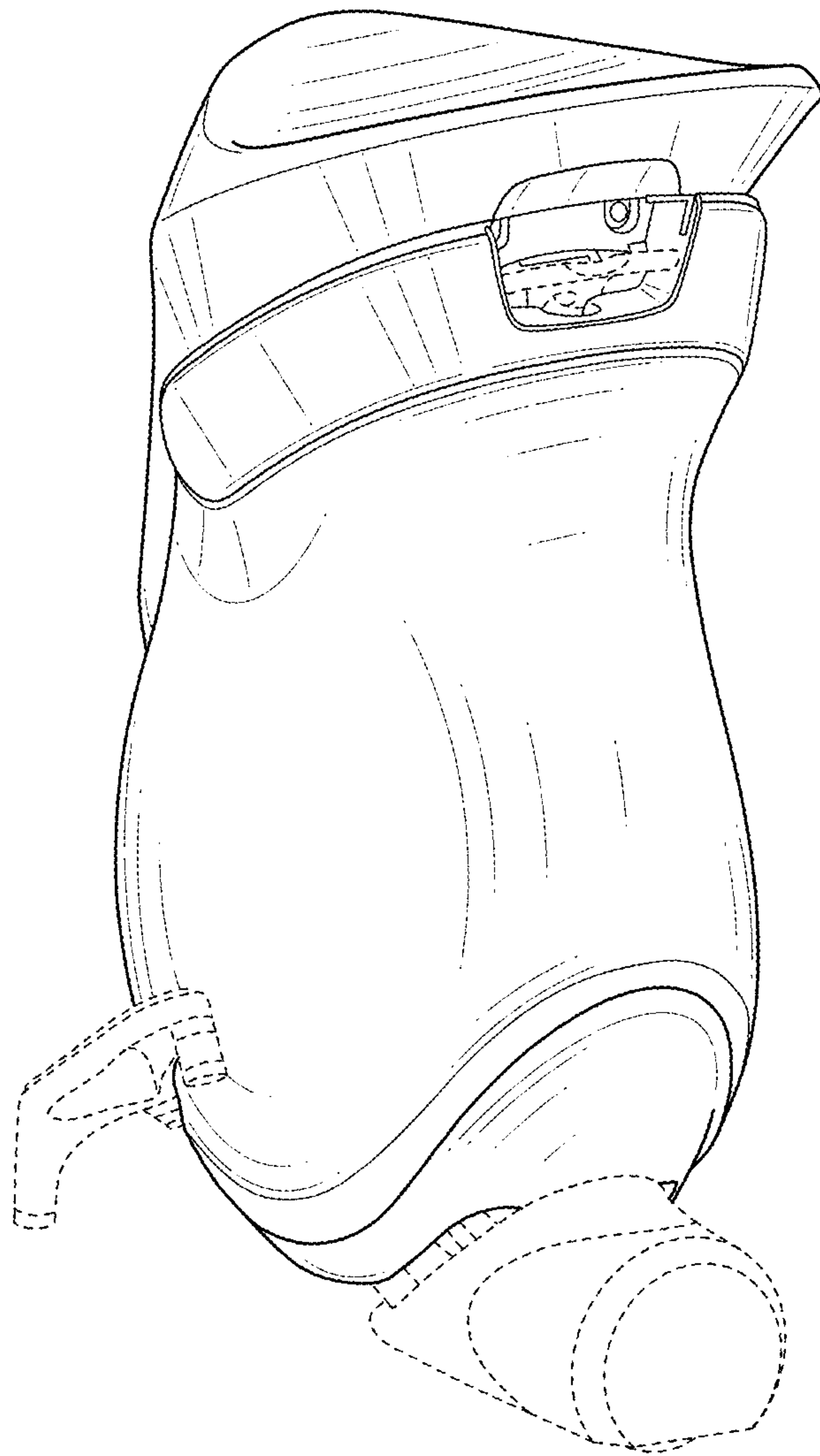

FIG. 13

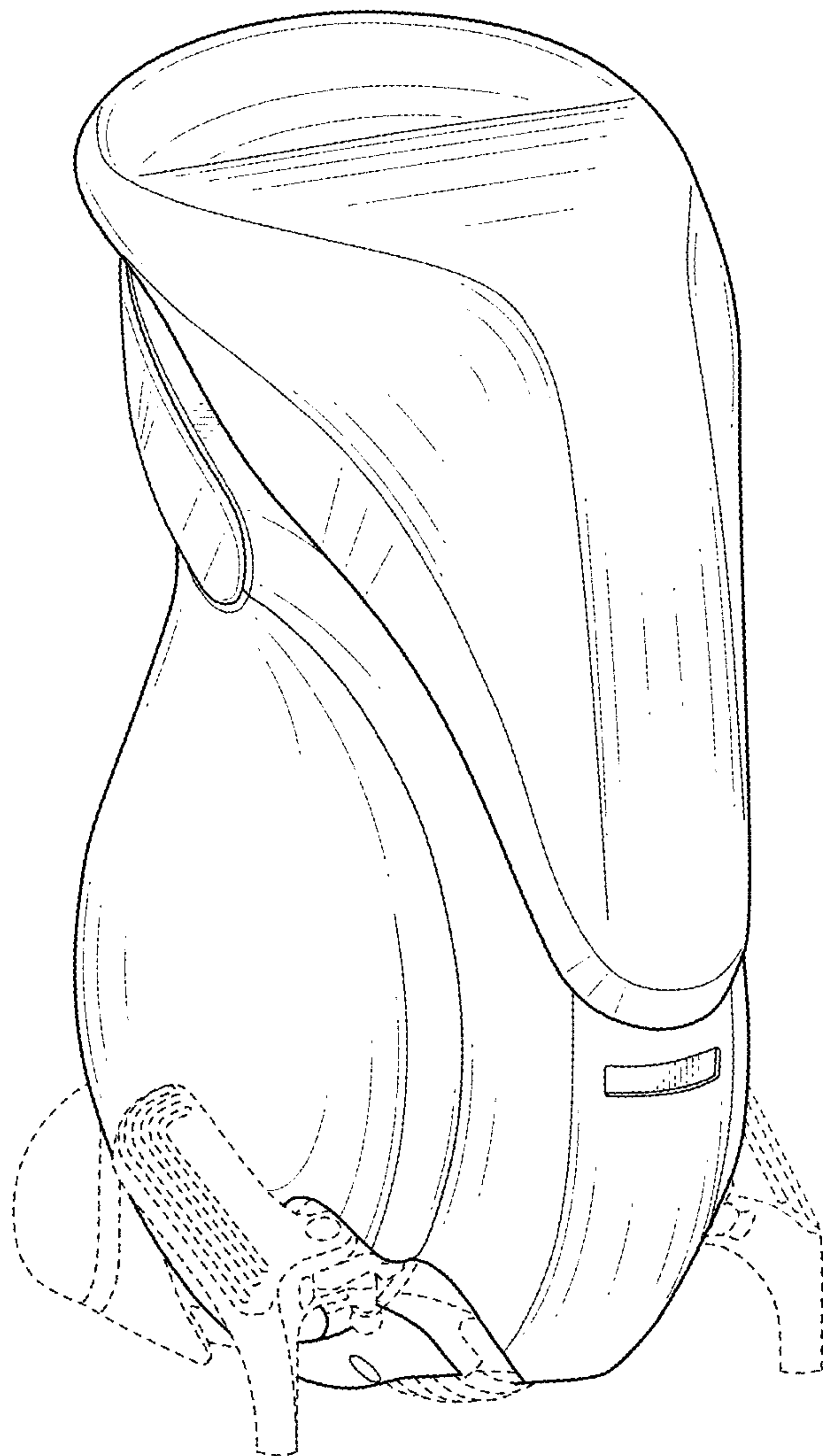

FIG. 14

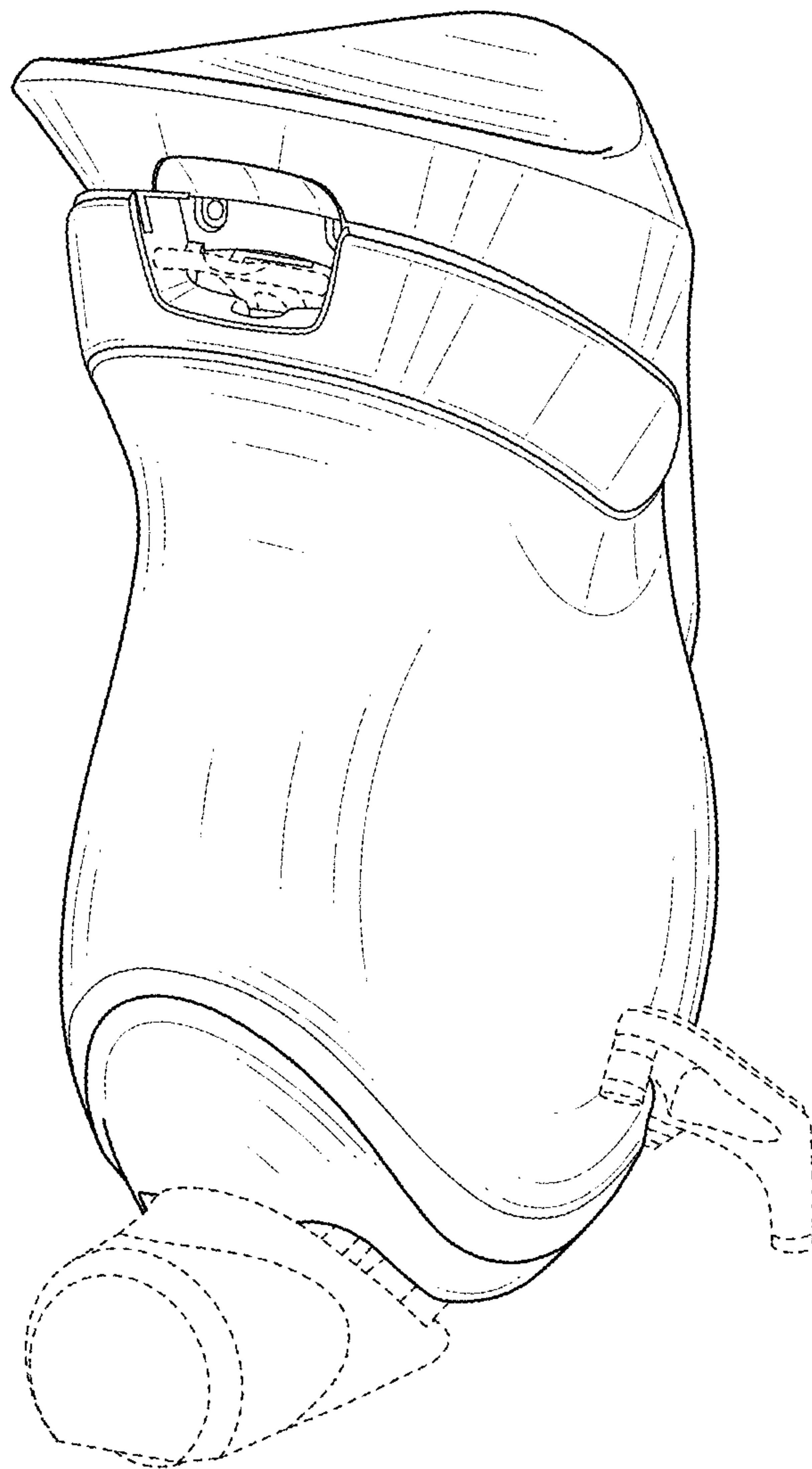

FIG. 15

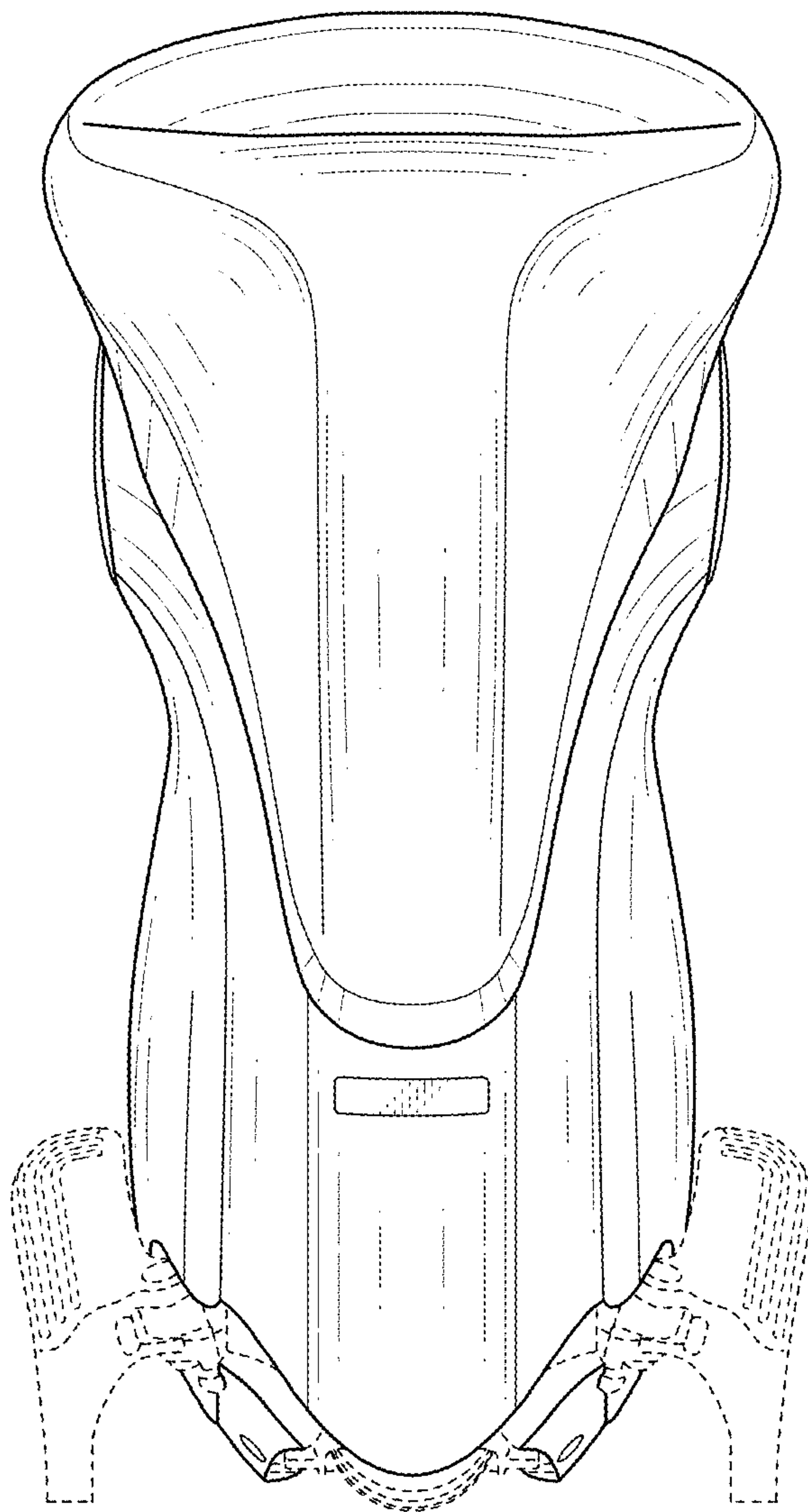

FIG. 16

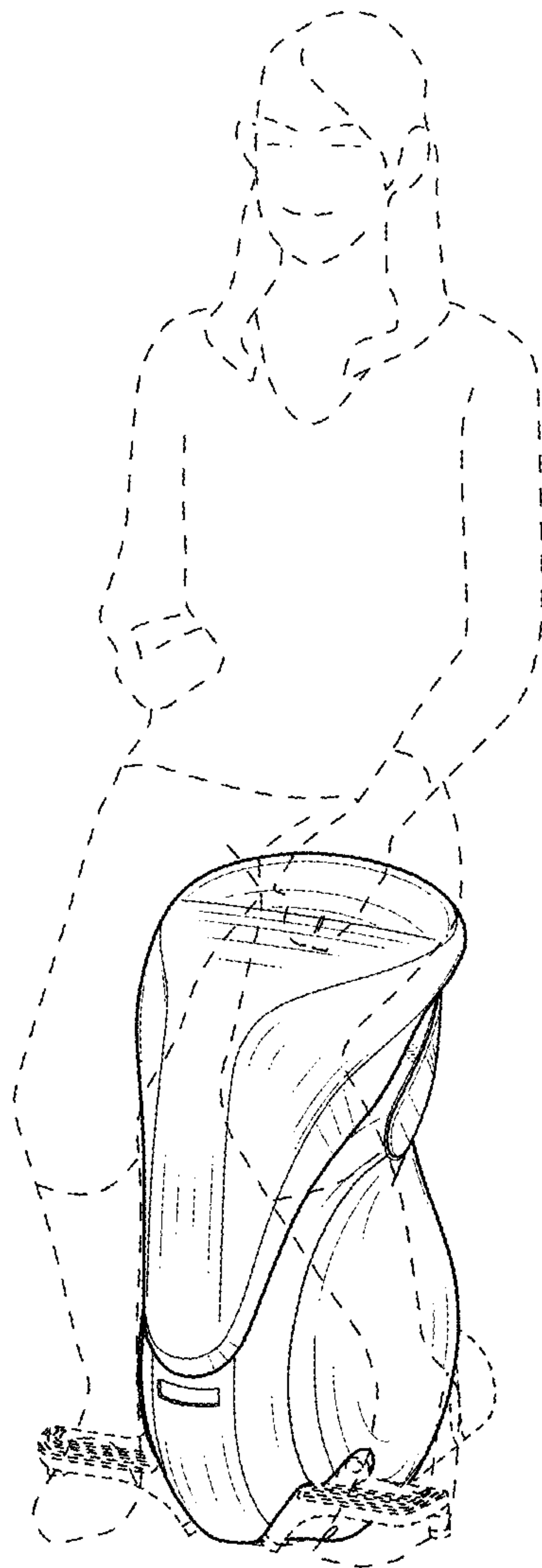

FIG. 17

