



US00D774953S

(12) **United States Design Patent**
Grech

(10) **Patent No.:** **US D774,953 S**

(45) **Date of Patent:** **** Dec. 27, 2016**

(54) **VEHICLE CAB**

(71) Applicant: **Edward P Grech**, Riverside, CA (US)

(72) Inventor: **Edward P Grech**, Riverside, CA (US)

(**) Term: **14 Years**

(21) Appl. No.: **29/480,926**

(22) Filed: **Jan. 30, 2014**

(51) **LOC (10) Cl.** **12-08**

(52) **U.S. Cl.**
USPC **D12/96**

(58) **Field of Classification Search**
USPC D12/84, 88, 93, 96, 97, 99, 181, 190,
D12/191, 196, 400; D21/424, 434, 581;
180/89.16, 89.18, 89.19, 903; 280/727,
280/770, 848; 296/91, 180.1-180.5, 183.1
CPC B62D 35/001; B60J 1/02
See application file for complete search history.

(56) **References Cited**

U.S. PATENT DOCUMENTS

3,469,881	A	9/1969	McNamee	
3,656,798	A	4/1972	Dodgen et al.	
5,188,419	A	2/1993	Liethen	
D376,772	S *	12/1996	Martin	D12/96
5,641,558	A	6/1997	Noda et al.	
D384,914	S *	10/1997	Bingaman	D12/97
D391,524	S *	3/1998	Anderson et al.	D12/96
5,860,466	A	1/1999	Kao	
D409,951	S *	5/1999	Grech	D12/84
D411,141	S *	6/1999	Gerisch et al.	D12/96
D422,944	S *	4/2000	Hellhake et al.	D12/96
D425,450	S *	5/2000	Barraclough et al.	D12/96

D436,894	S *	1/2001	Barraclough et al.	D12/96
D475,657	S *	6/2003	Wong et al.	D12/96
D595,197	S	6/2009	Woodley et al.	
D601,064	S	9/2009	Golden et al.	
D601,065	S	9/2009	Gueler et al.	
D607,387	S	1/2010	Golden et al.	
D607,388	S	1/2010	Mahoney	
7,694,712	B2	4/2010	Schimko et al.	
D656,866	S *	4/2012	Wise	D12/93
D692,357	S	10/2013	Campbell et al.	
D708,557	S *	7/2014	Grech	D12/183
D711,786	S *	8/2014	Brzustowicz et al.	D12/96
2004/0069425	A1	4/2004	Hansen et al.	
2005/0269834	A1	12/2005	Toth et al.	
2014/0197660	A1 *	7/2014	Grech	296/178

* cited by examiner

Primary Examiner — Darlington Ly

(74) *Attorney, Agent, or Firm* — John J. Connors;
Connors & Assoc. pc

(57) **CLAIM**

The ornamental design for a vehicle cab, as shown and described.

DESCRIPTION

FIG. 1 is a perspective view of the vehicle cab according to my design;
FIG. 2 is a left side elevation view thereof;
FIG. 3 is a front elevation view thereof;
FIG. 4 is a top plan view thereof; and,
FIG. 5 is a right side elevation view thereof.
The broken line showing a vehicle is for the purpose of illustrating environmental structure and forms no part of the claimed design.

1 Claim, 2 Drawing Sheets

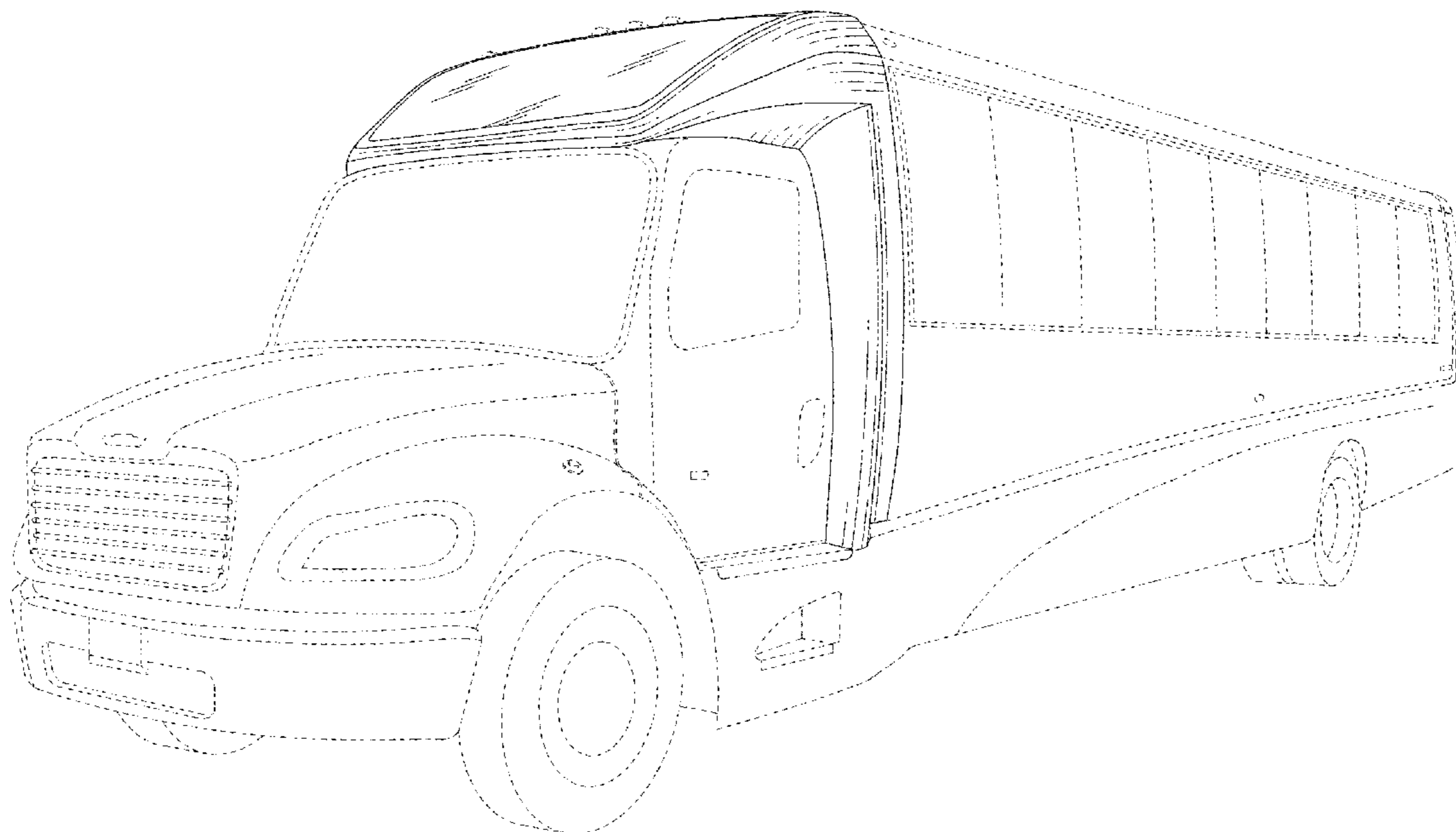

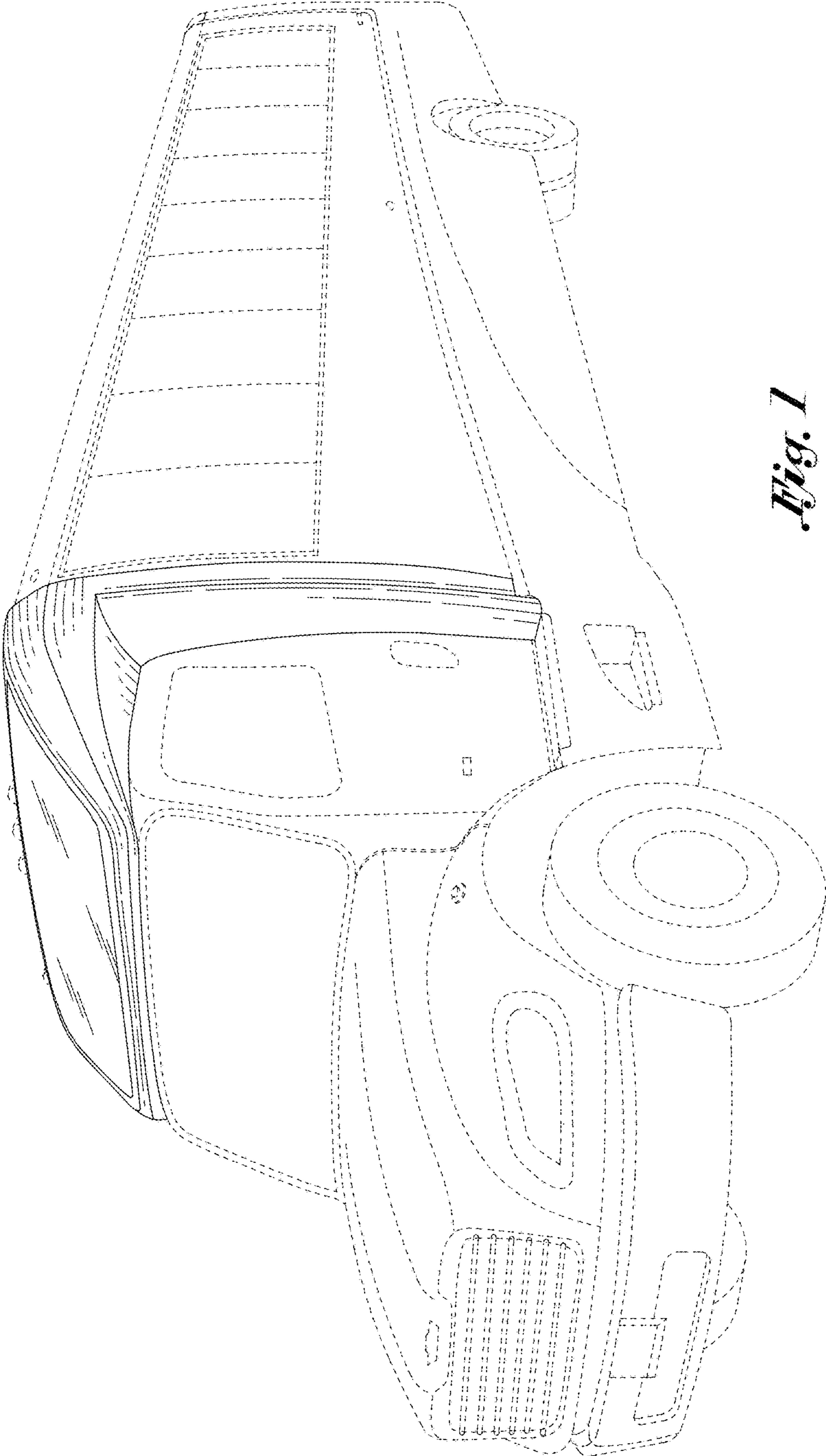

Fig. 1

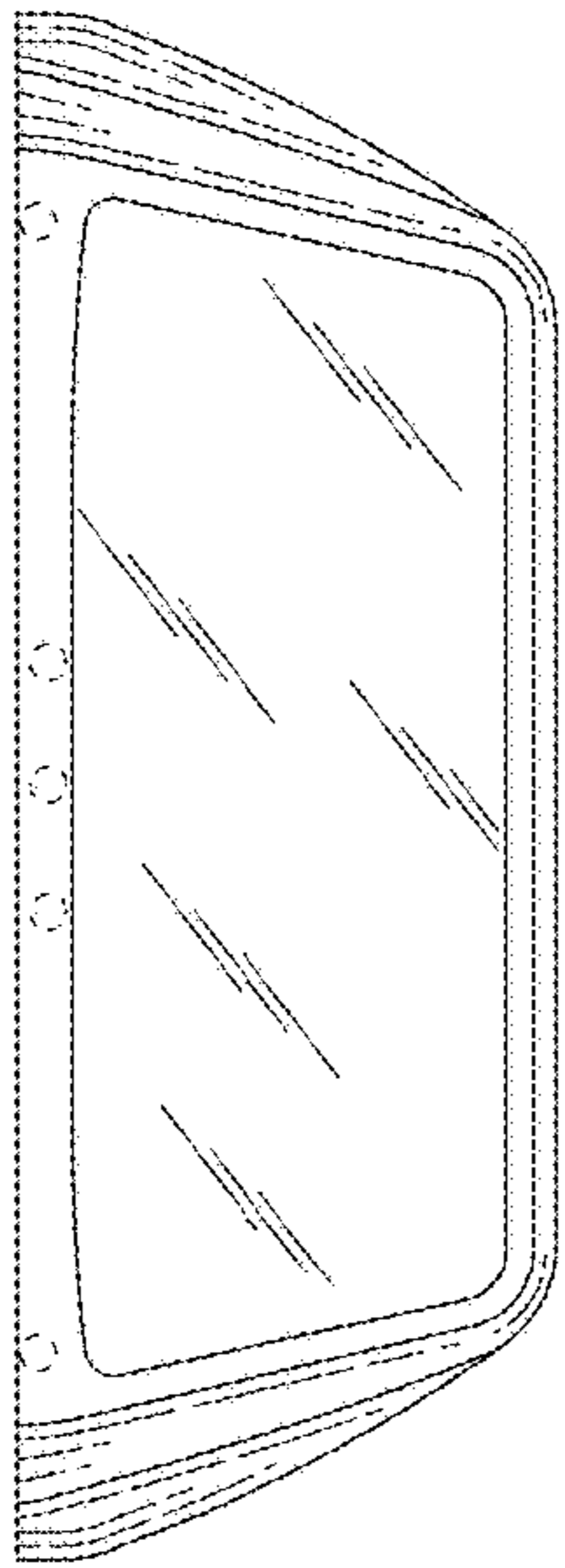

Fig. 1

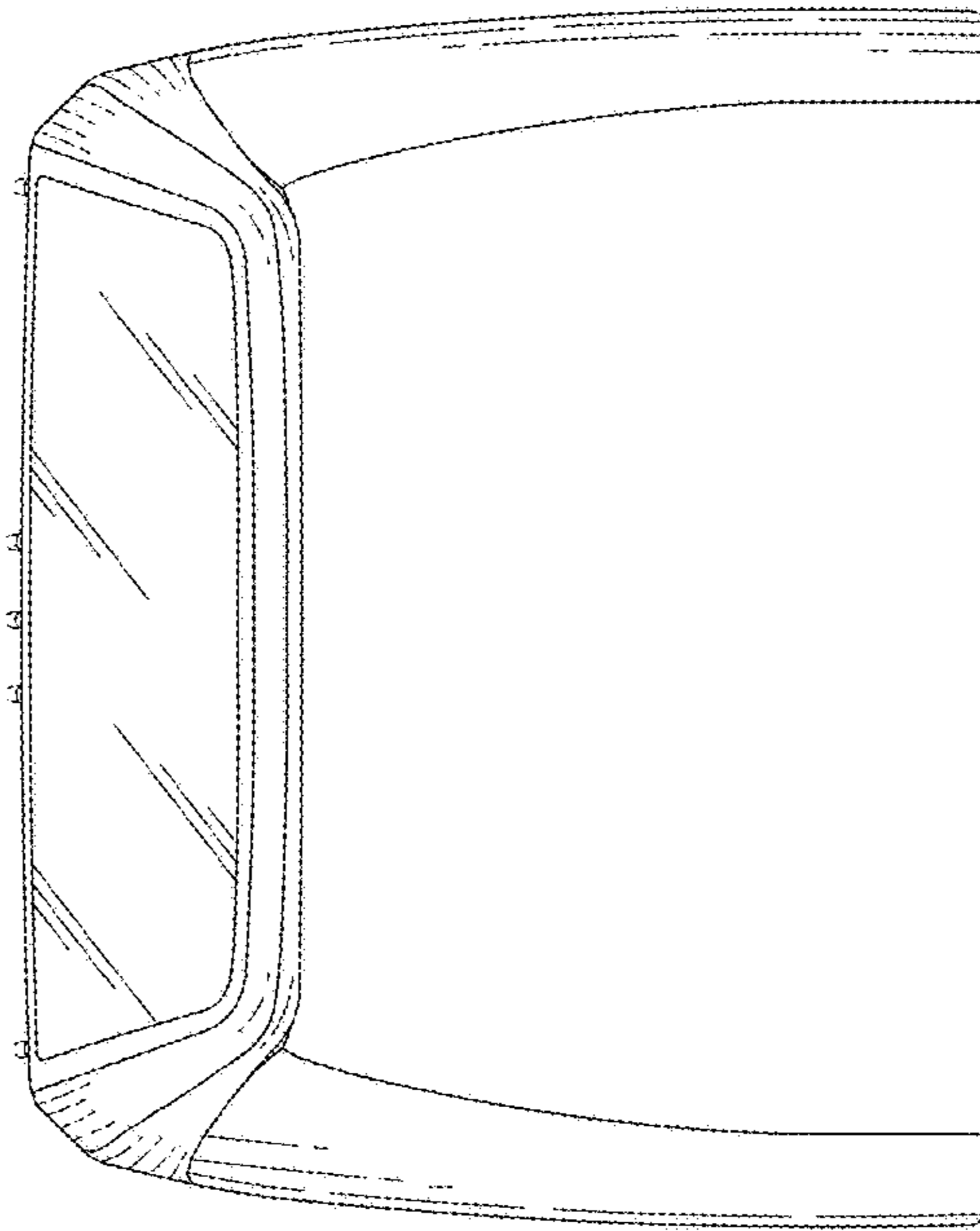

Fig. 2

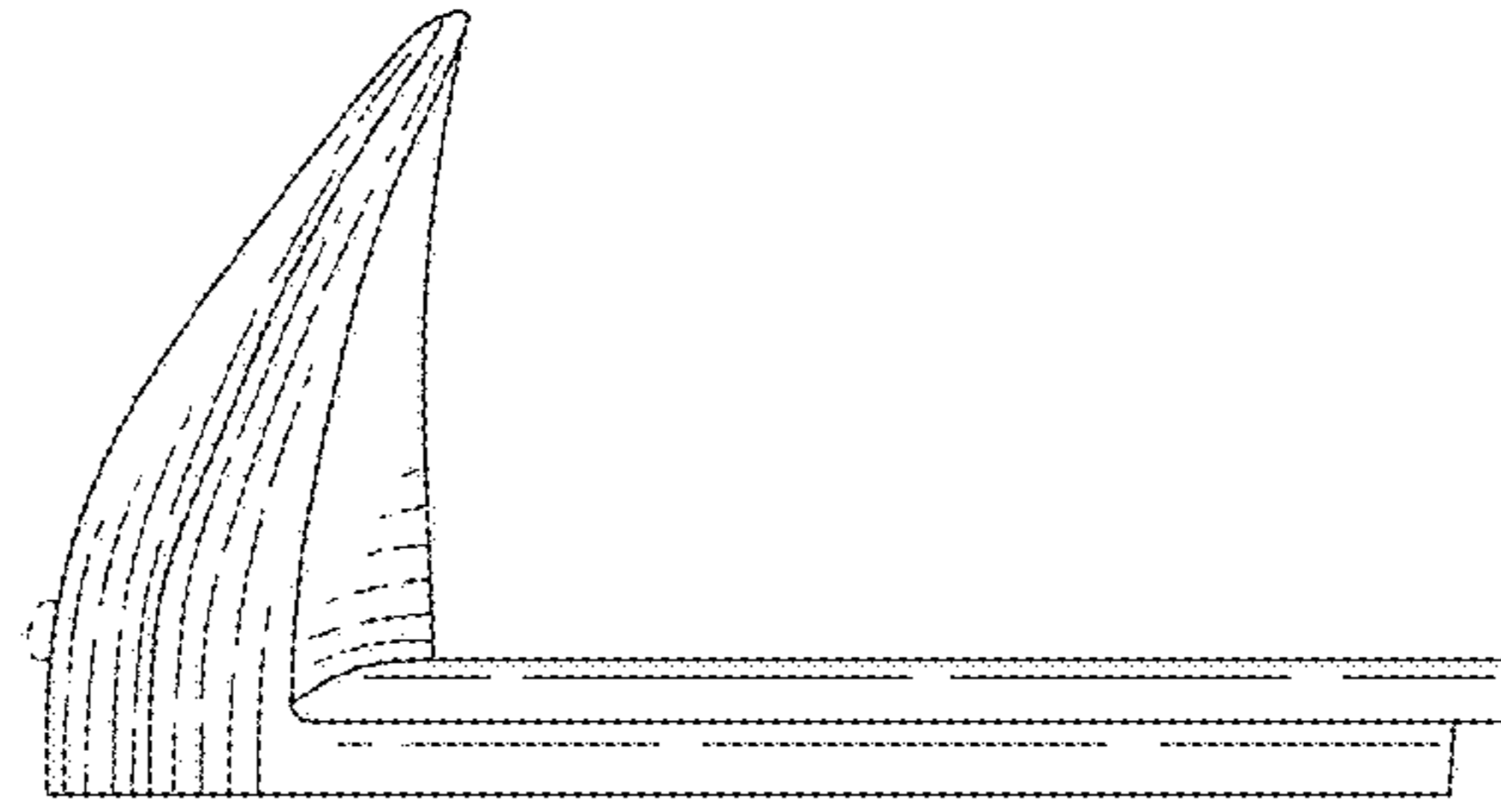

Fig. 3

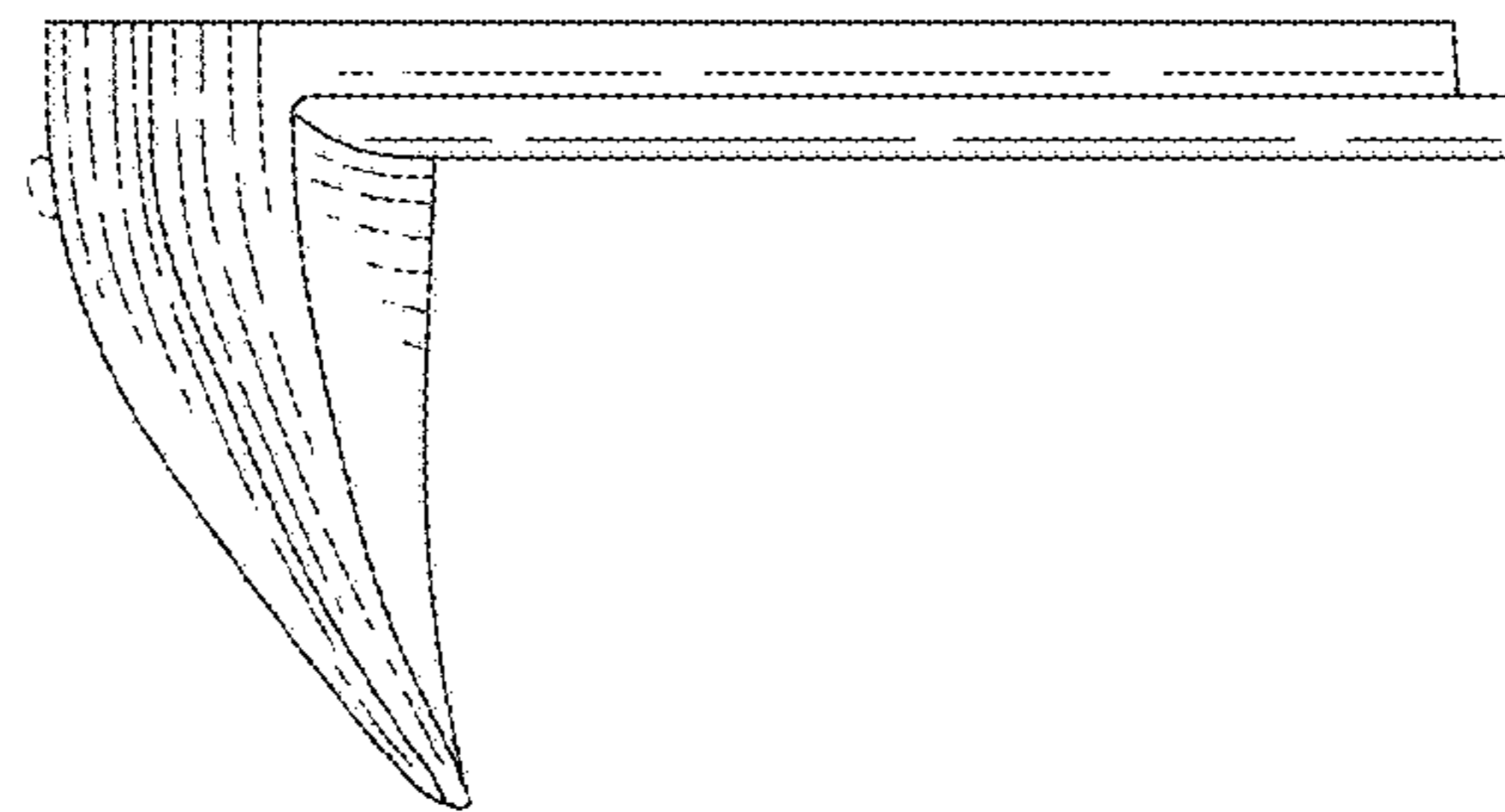

Fig. 4