



US00D774884S

(12) **United States Design Patent** (10) **Patent No.:** **US D774,884 S**
Deshpande et al. (45) **Date of Patent:** **** Dec. 27, 2016**

- (54) **PACKAGE FOR POINT OF SALE** 2,839,185 A * 6/1958 Isaacs B65D 85/677
206/49
- (71) Applicant: **Cequent Consumer Products, Inc.,** 5,919,074 A * 7/1999 Honda A63H 3/50
Solon, OH (US) 206/779
- (72) Inventors: **Dhananjay Deshpande,** Twinsburg, OH D428,738 S * 8/2000 Brozak, Jr. D6/678.3
(US); **Cynthia Eubank,** Barberton, OH 6,170,674 B1 * 1/2001 Caterinacci A47F 7/0042
(US); **Laurie Heiser,** Sagamore Hills, 211/41.1
OH (US); **Matt Romanak,** Garfield D597,766 S * 8/2009 Nealon D6/683
Heights, OH (US) D625,530 S * 10/2010 Robbins, III D6/683
8,522,970 B2 * 9/2013 Hsieh B65D 5/5021
206/320

* cited by examiner

(73) Assignee: **Cequent Consumer Products, Inc.,**
Solon, OH (US)

Primary Examiner — Rhea Shields

(**) Term: **15 Years**

(74) *Attorney, Agent, or Firm* — McDonald Hopkins LLC

(21) Appl. No.: **29/540,915**

(57) **CLAIM**

(22) Filed: **Sep. 29, 2015**

The ornamental design for a package for point of sale, as shown and described.

Related U.S. Application Data

(62) Division of application No. 29/518,546, filed on Feb. 25, 2015, now Pat. No. Des. 742,215, which is a division of application No. 29/464,998, filed on Aug. 22, 2013, now Pat. No. Des. 730,168.

(51) **LOC (10) Cl.** **09-03**

(52) **U.S. Cl.**
USPC **D9/415**

(58) **Field of Classification Search**
USPC D9/415, 722, 456, 457, 749, 418, 423,
D9/424, 428, 431, 499; 229/407, 406;
206/731, 769, 770, 461, 462, 776, 495
CPC A47G 23/025; A47F 7/0042; B65D 5/5021;
B65D 85/677; A63H 3/50; G09F 5/04
See application file for complete search history.

(56) **References Cited**

U.S. PATENT DOCUMENTS

- 42,943 A * 5/1864 Hance A47G 23/025
206/572
- 2,322,057 A * 6/1943 Poutinen G09F 5/04
206/348

DESCRIPTION

FIG. 1 is a perspective view of a package for point of sale showing our new design;
 FIG. 2 is a front view thereof;
 FIG. 3 is a rear view thereof;
 FIG. 4 is a first side view thereof;
 FIG. 5 is a second side view thereof;
 FIG. 6 is a top view thereof;
 FIG. 7 is a bottom view thereof;
 FIG. 8 is a perspective view of a second embodiment of a package for point of sale showing our new design;
 FIG. 9 is a front view thereof;
 FIG. 10 is a rear view thereof;
 FIG. 11 is a first side view thereof;
 FIG. 12 is a second side view thereof;
 FIG. 13 is a top view thereof; and,
 FIG. 14 is a bottom view thereof.

In the drawings, the broken lines are for the purpose of illustrating environment only and form no part of the claimed design.

1 Claim, 10 Drawing Sheets

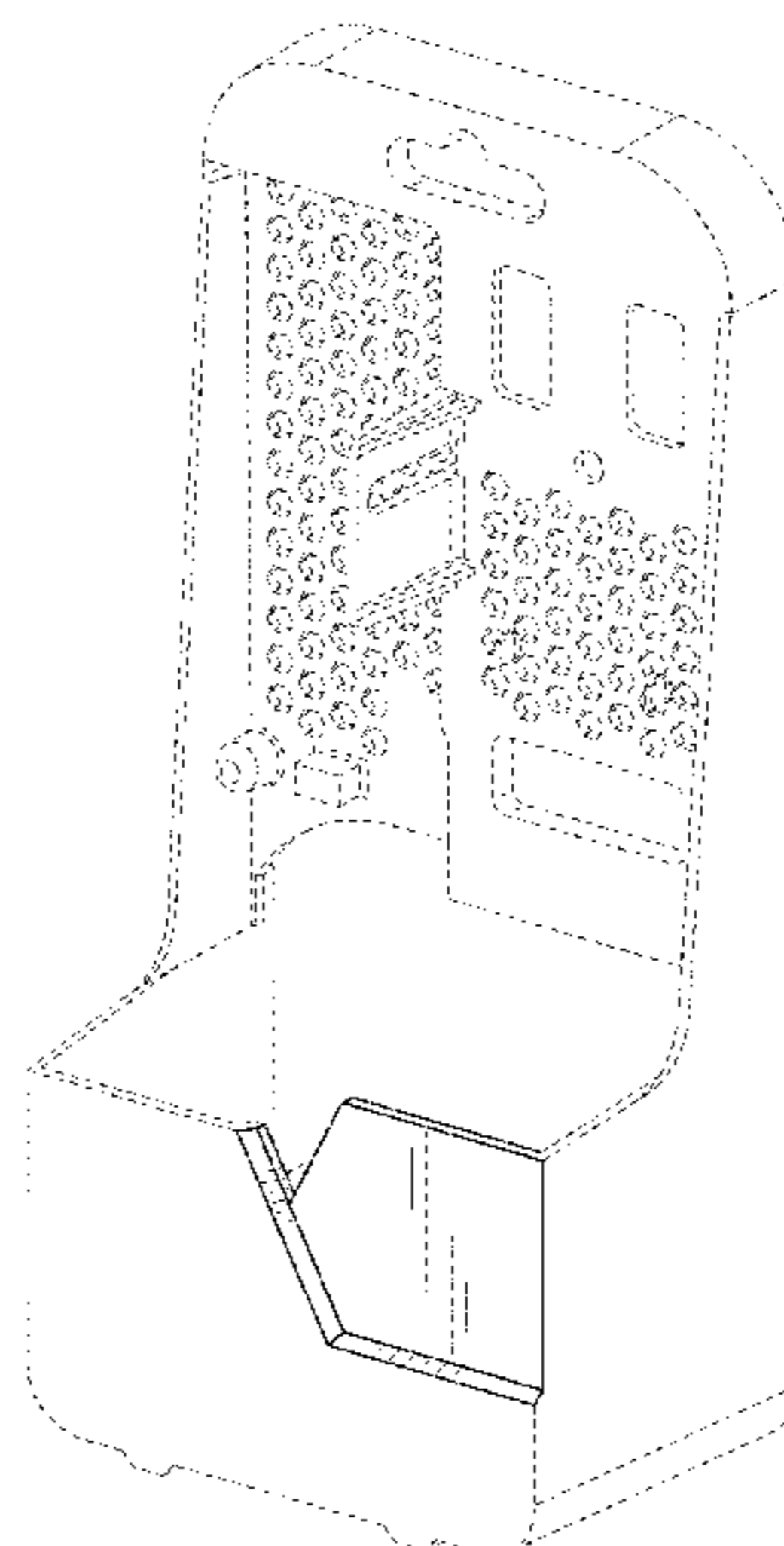

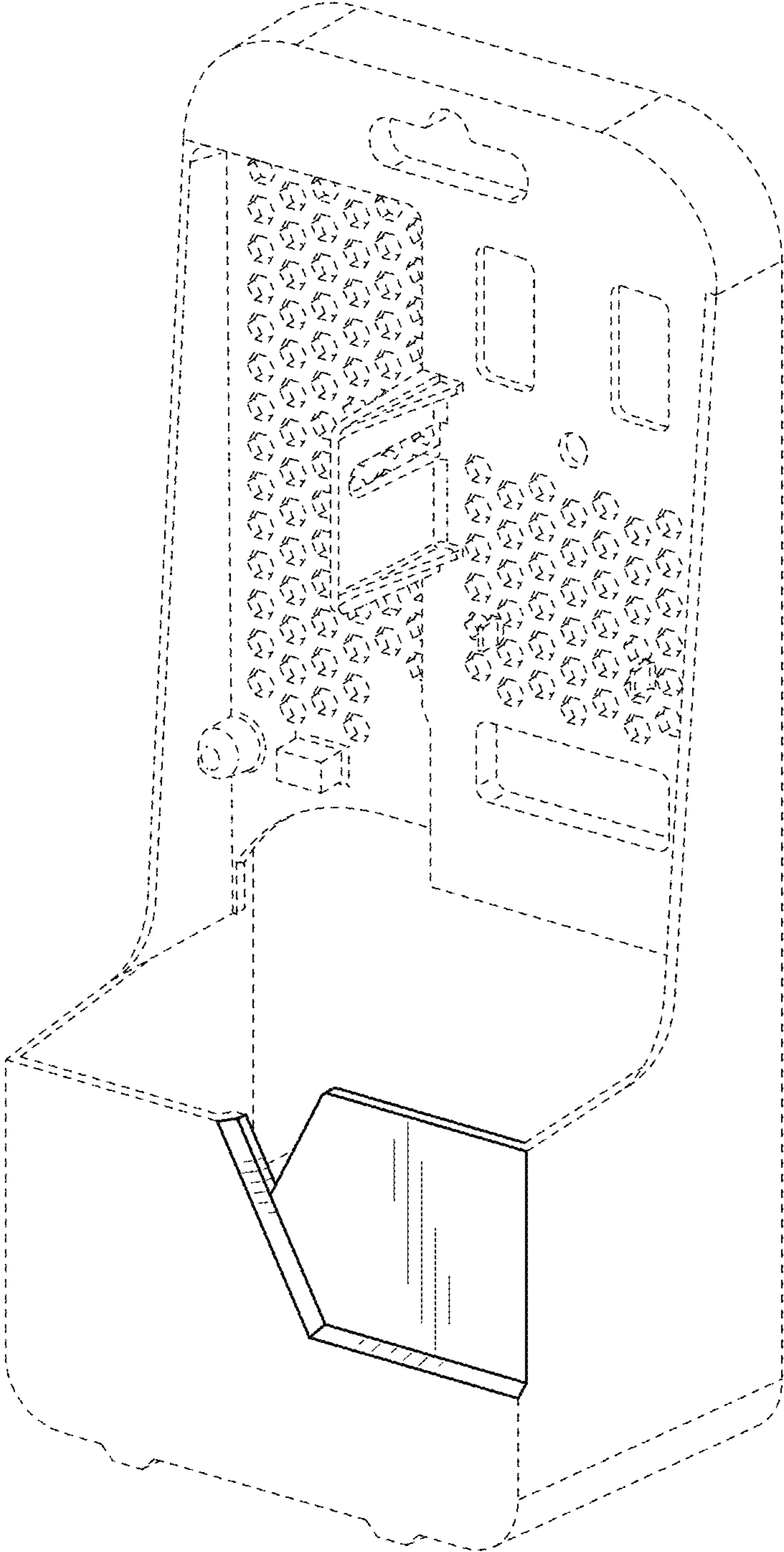

FIG. 1

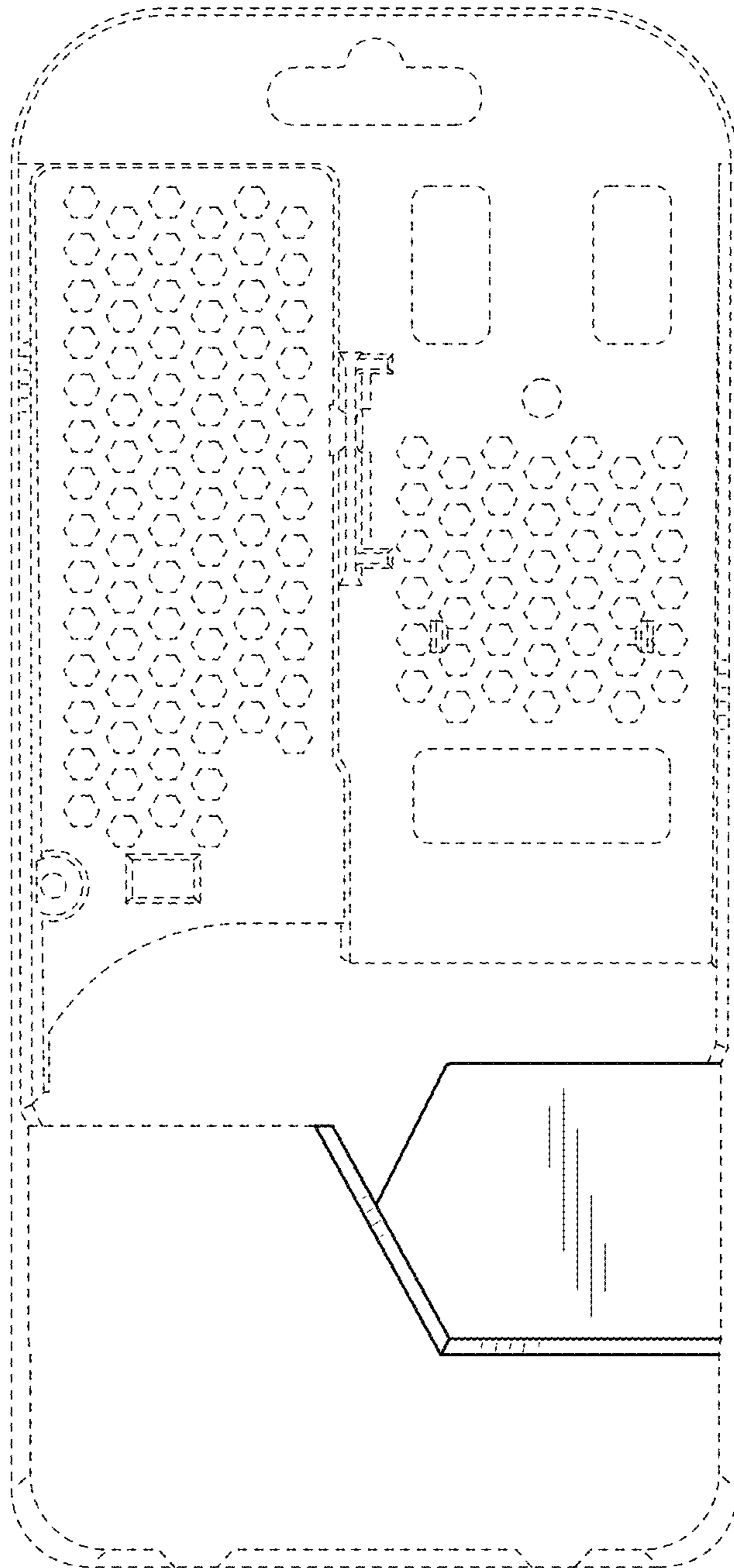

FIG. 2

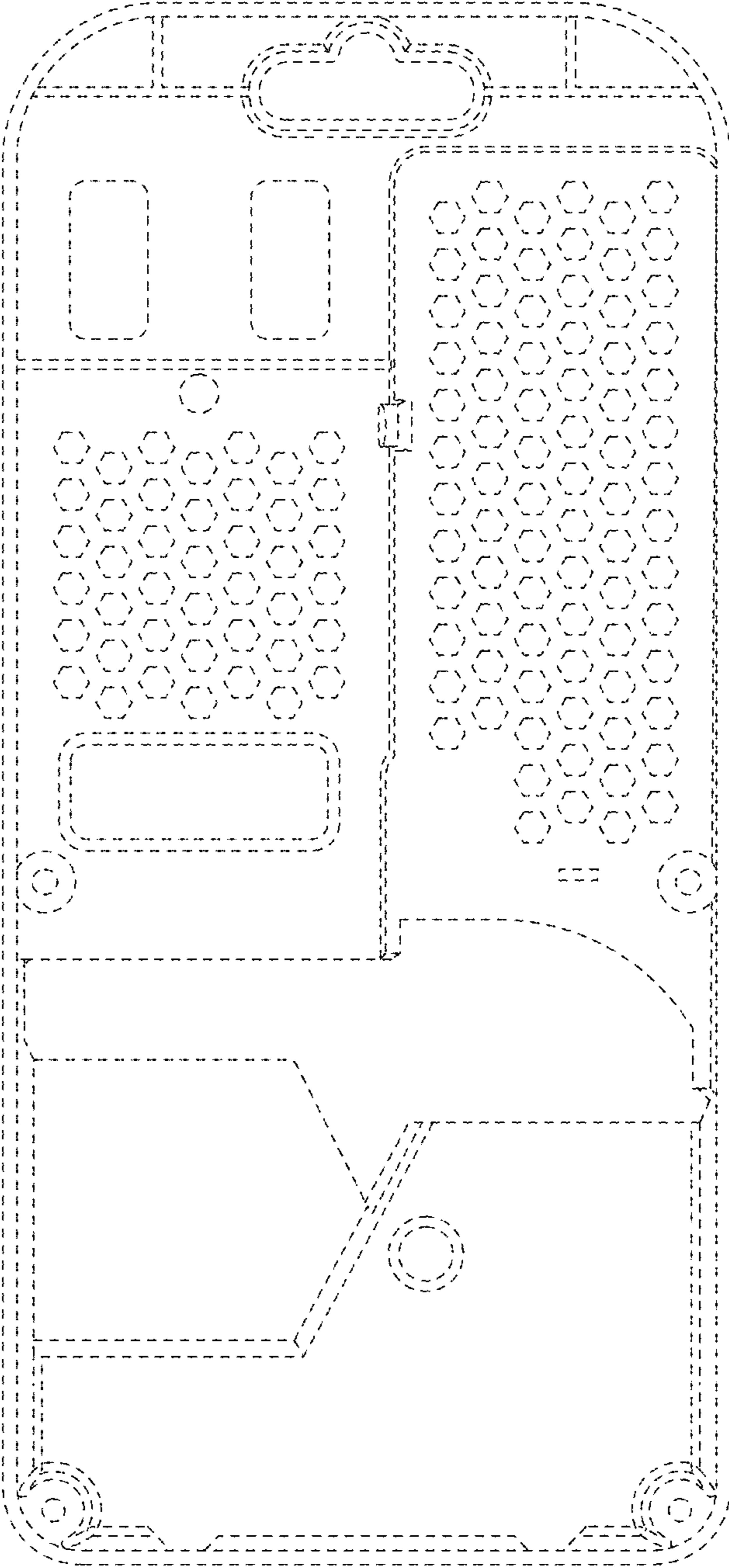

FIG. 3

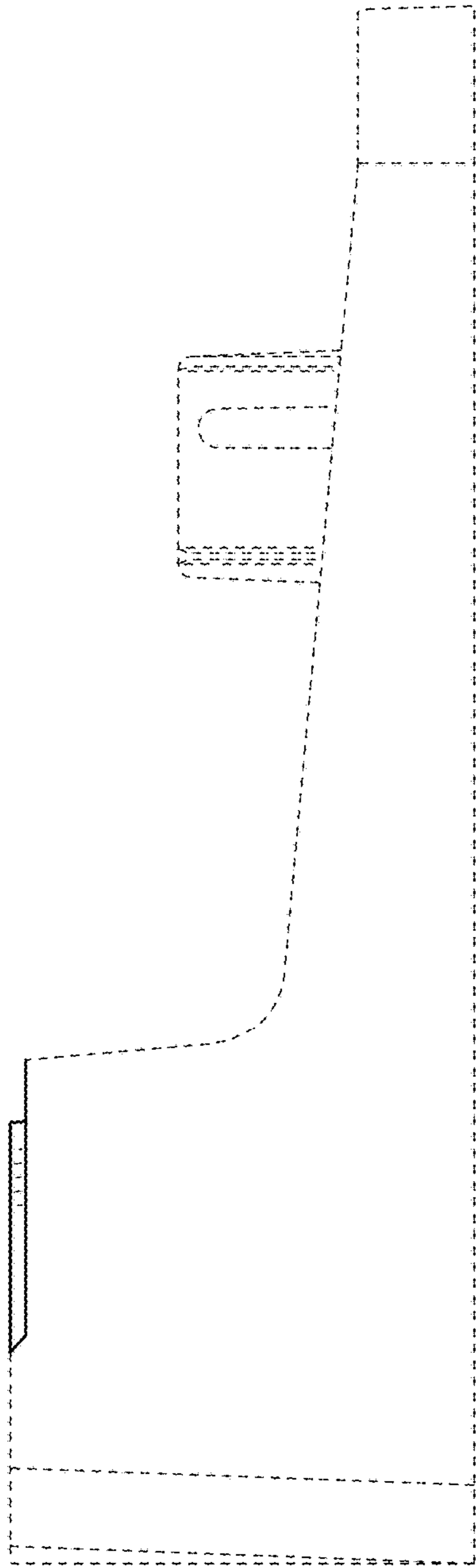

FIG. 4

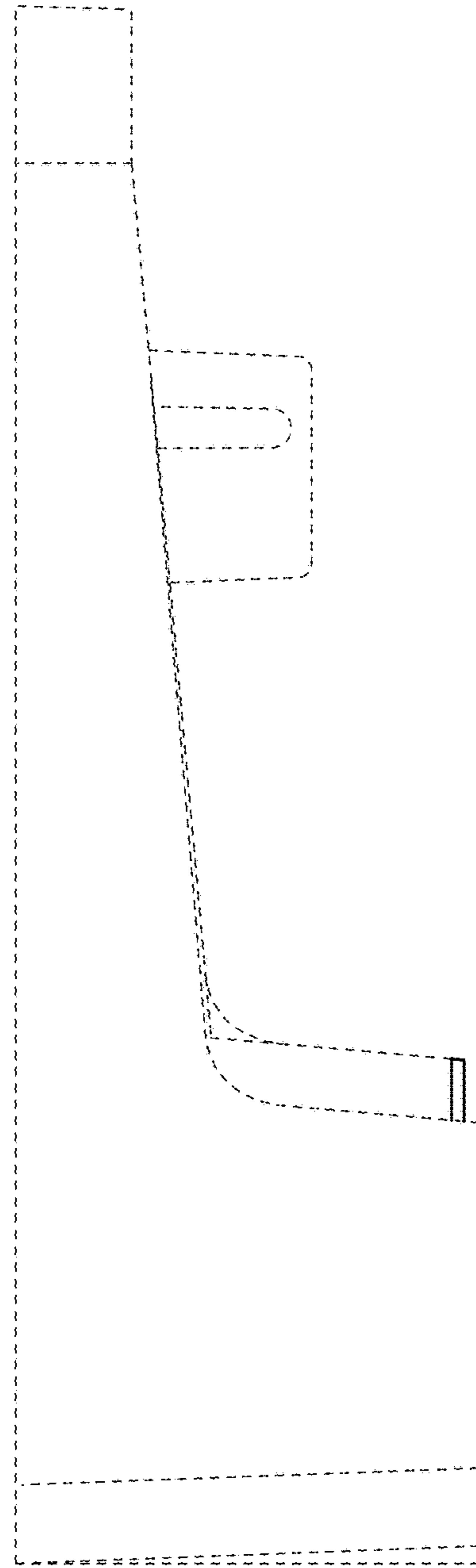

FIG. 5

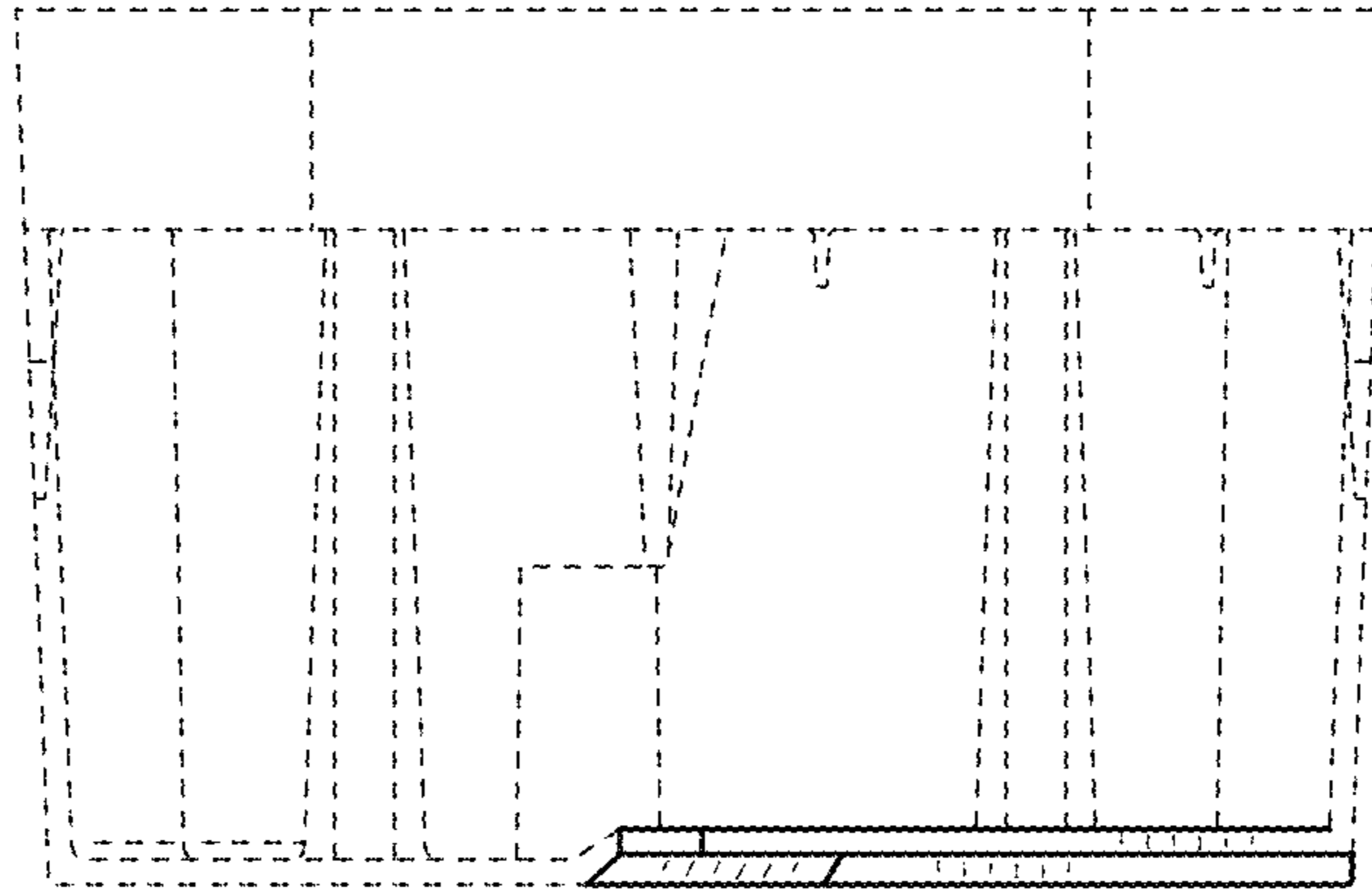

FIG. 6

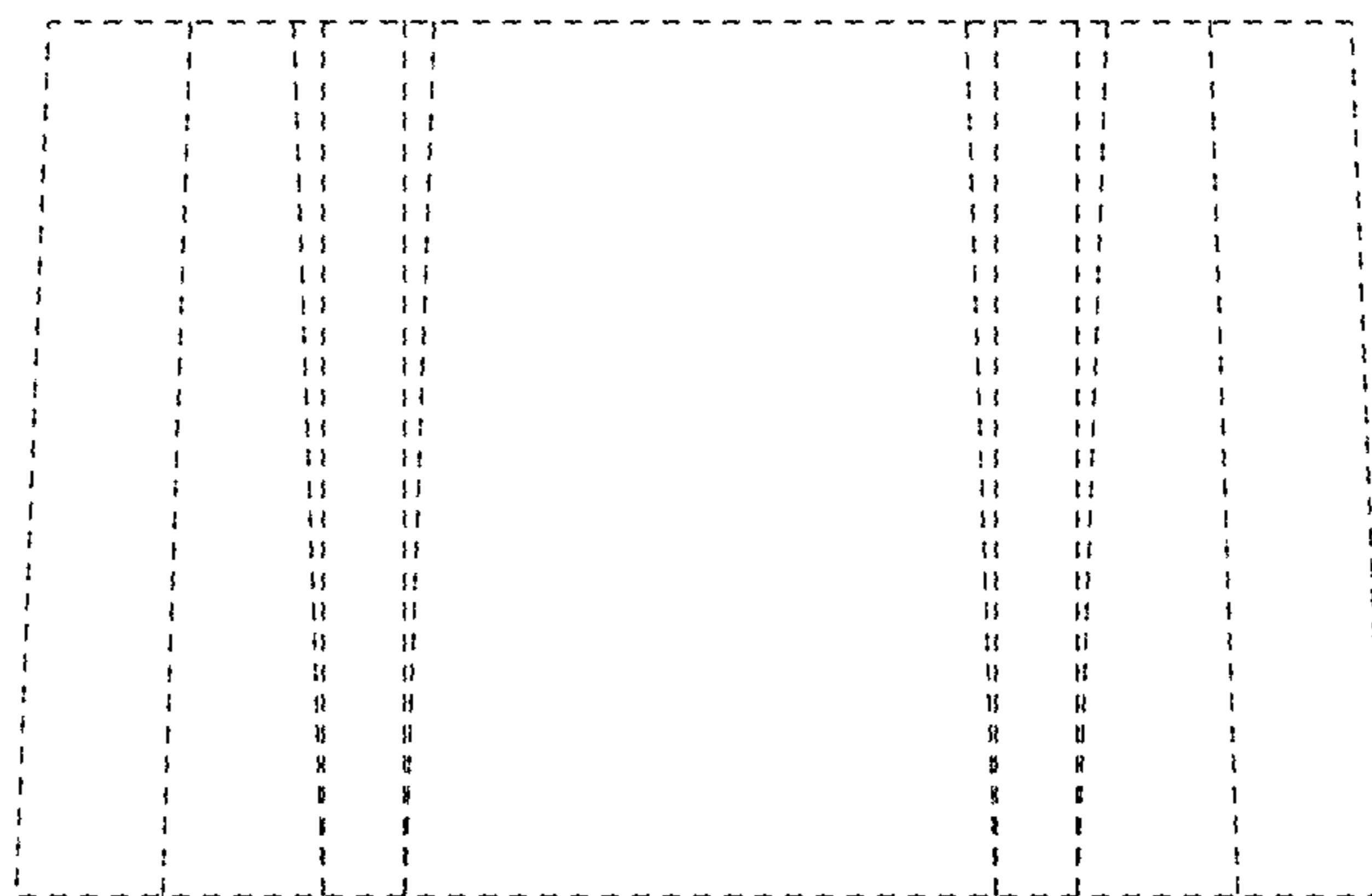

FIG. 7

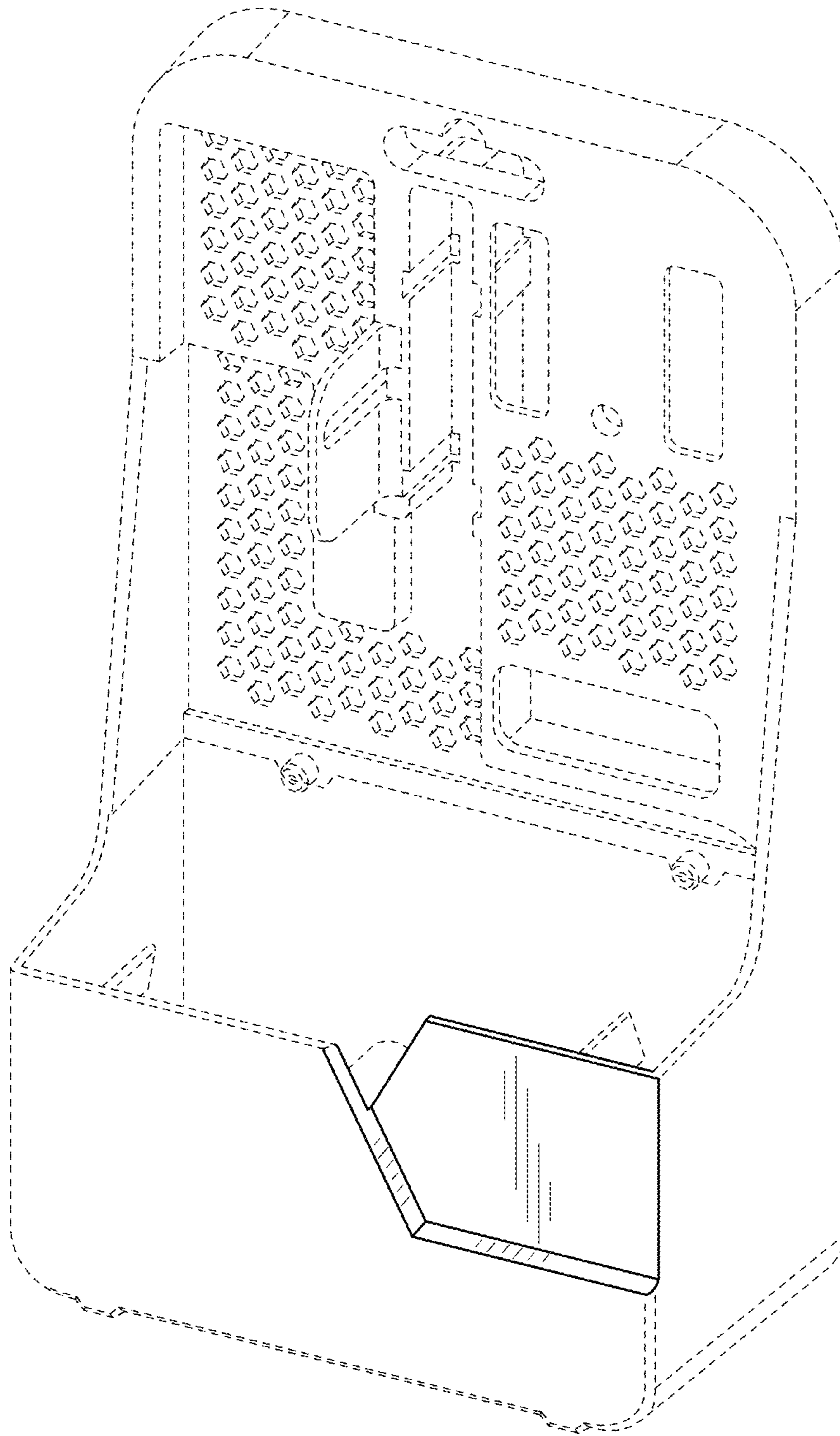

FIG. 8

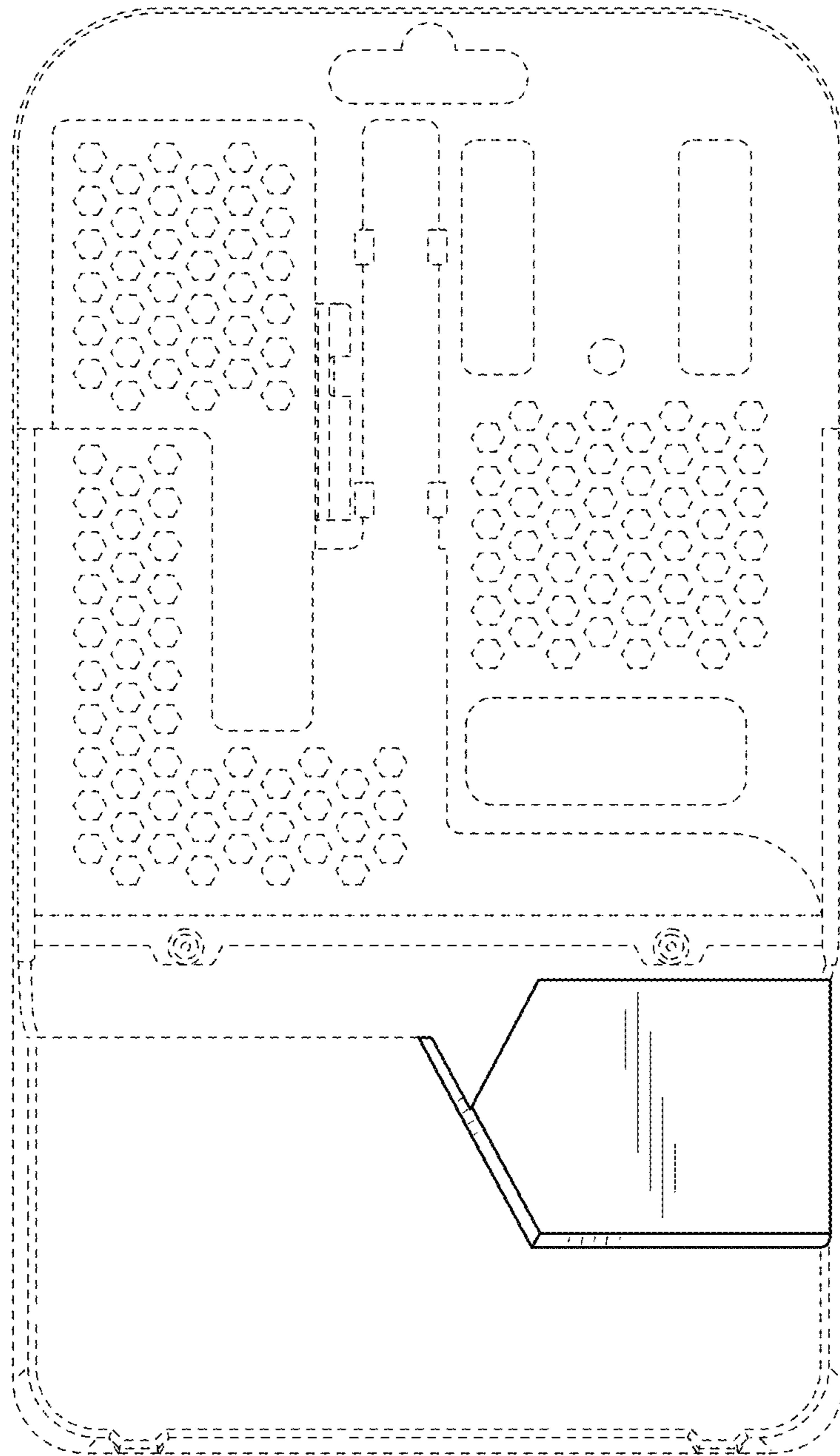

FIG. 9

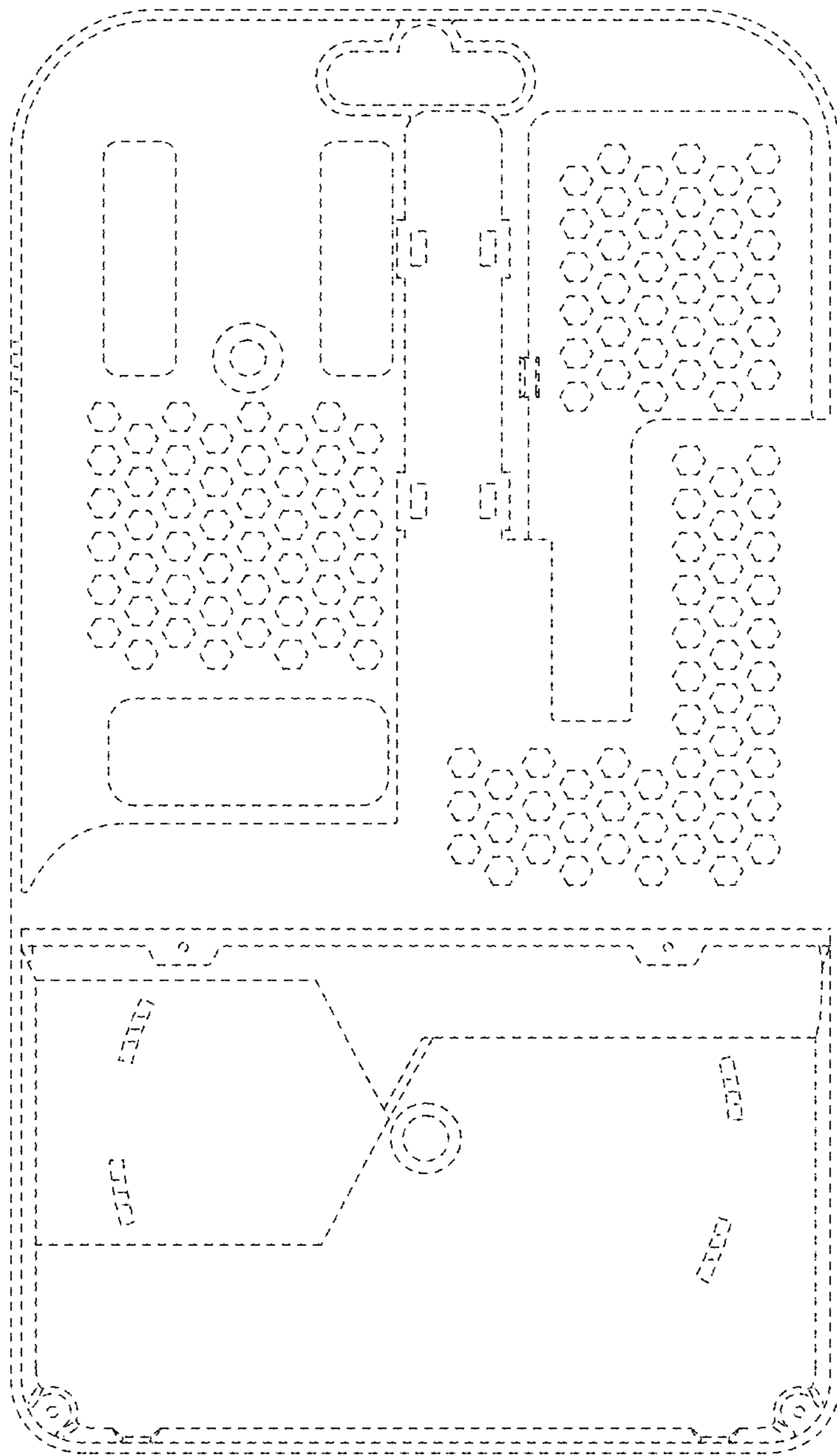

FIG. 10

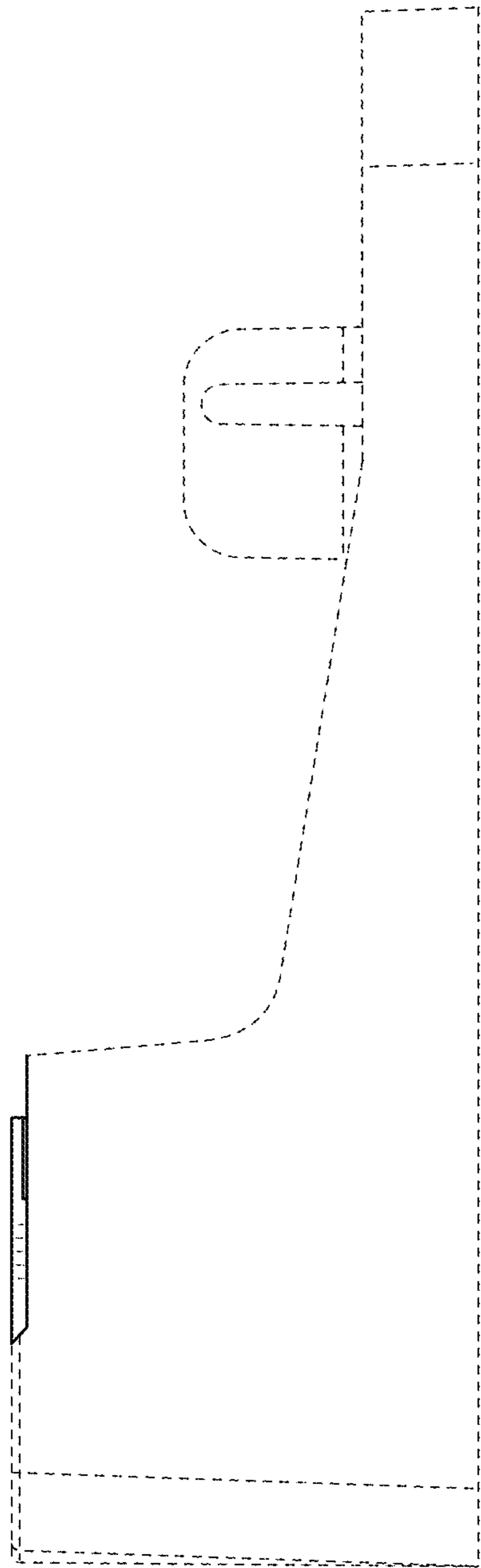

FIG. 11

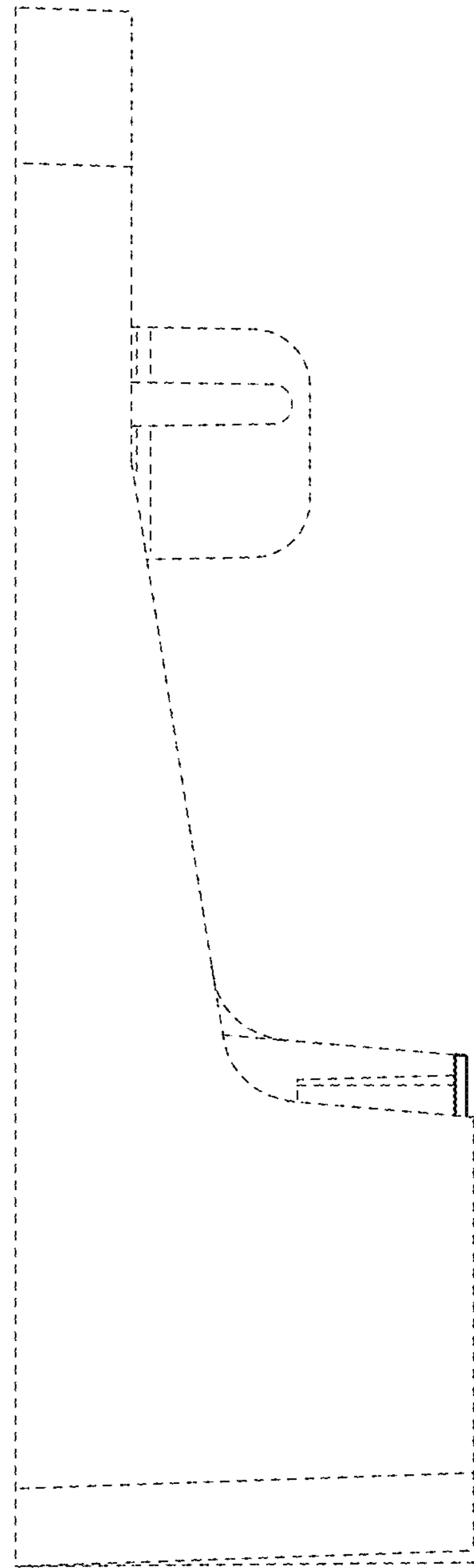

FIG. 12

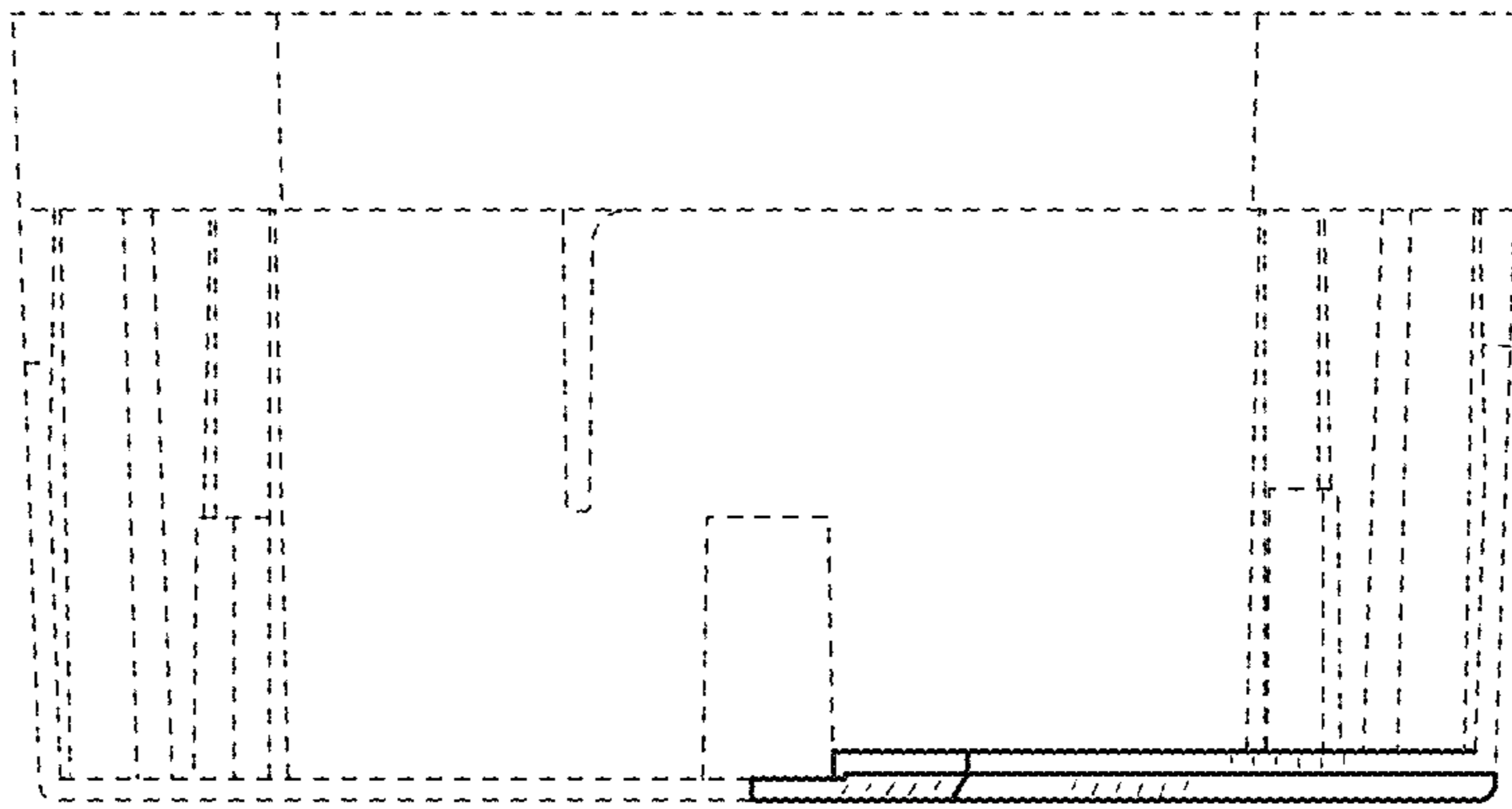

FIG. 13

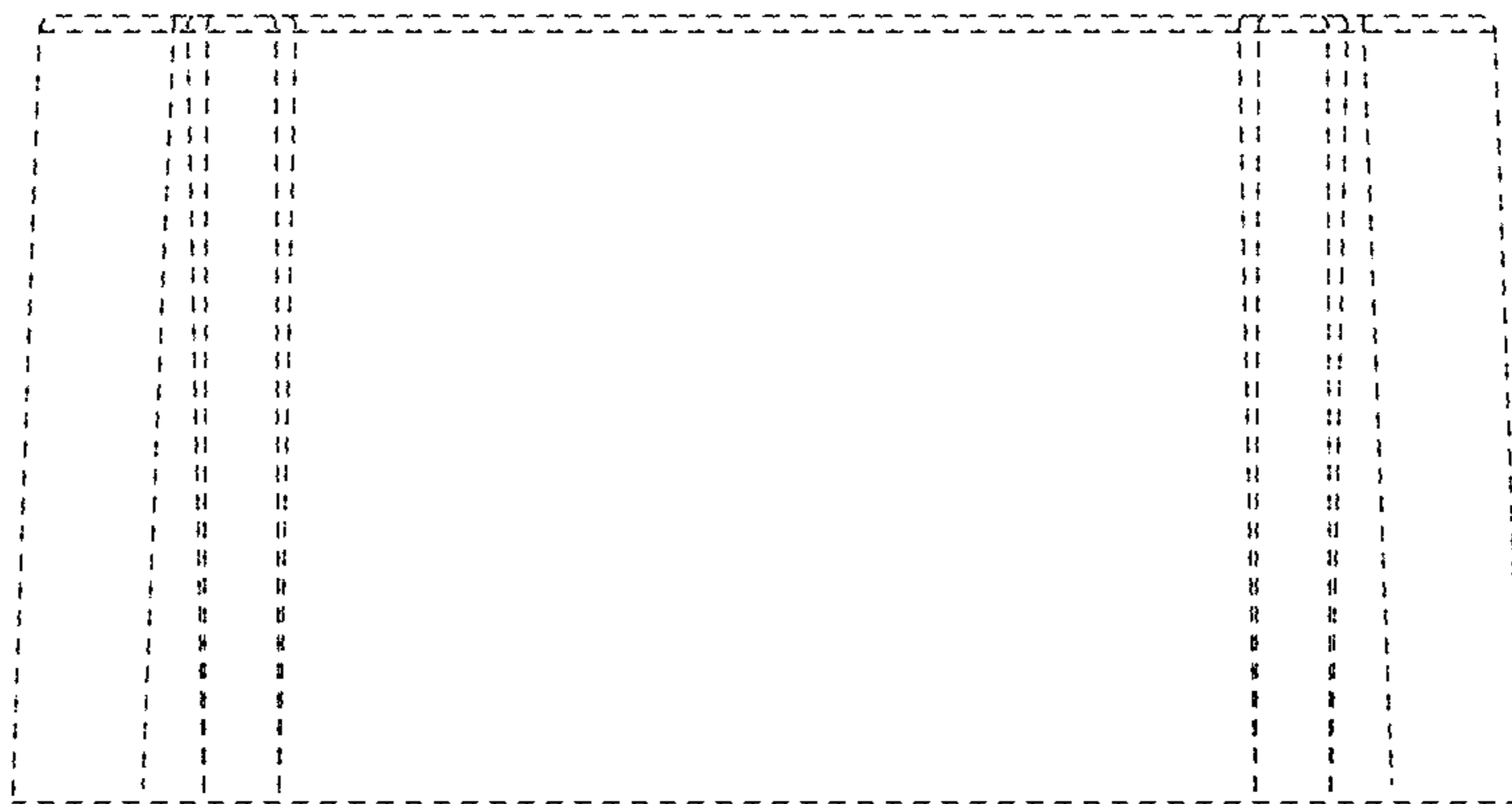

FIG. 14