



US00D774043S

(12) **United States Design Patent** (10) **Patent No.:** **US D774,043 S**
Thompson et al. (45) **Date of Patent:** **** Dec. 13, 2016**

(54) **DISPLAY SCREEN WITH GRAPHICAL USER INTERFACE FOR ABLATION GENERATOR**

FOREIGN PATENT DOCUMENTS

(71) Applicant: **St. Jude Medical, Cardiology Division, Inc.**, St. Paul, MN (US)

WO 97/45157 12/1997
WO 00/66020 11/2000

(Continued)

(72) Inventors: **Sara A. Thompson**, Maple Grove, MN (US); **Mark A. Catron**, Superior, CO (US); **Eric Collins**, Superior, CO (US); **Matija Klemenc**, Louisville, CO (US); **John B. Blix**, Maple Grove, MN (US)

OTHER PUBLICATIONS

Jaff, Michael R. et al, *Kidney Stenting Lowers Blood Pressure in Patients with Severe Hypertension; Catheterization and Cardiovascular Interventions*; Published Online: Jun. 27, 2012 (DOI: 10.1002/ccd.24449); Print Issue Date: Sep. 2012. URL: <http://onlinelibrary.wiley.com/doi/10.1002/ccd.24449/abstract>.

(Continued)

(73) Assignee: **St. Jude Medical, Cardiology Division, Inc.**, St. Paul, MN (US)

Primary Examiner — Eric Goodman

Assistant Examiner — Rachel Voorhies

(**) Term: **14 Years**

(74) *Attorney, Agent, or Firm* — Armstrong Teasdale LLP

(21) Appl. No.: **29/470,643**

(22) Filed: **Oct. 23, 2013**

(51) **LOC (10) Cl.** **14-04**

(52) **U.S. Cl.**
USPC **D14/485**

(58) **Field of Classification Search**
USPC D14/485-495
CPC ... A61B 8/52; A61B 2576/00; A61B 2576/02; A61B 8/461; A61B 8/465; G06F 19/3406; G06F 17/24; G06F 17/30056; G06F 2203/04803-2203/04805; H04N 1/00198; H04N 21/234336

See application file for complete search history.

(57) **CLAIM**

The ornamental design for a display screen with graphical user interface for ablation generator, as shown and described.

DESCRIPTION

The file of this patent contains at least one drawing/photograph executed in color. Copies of this patent with color drawing(s)/photograph(s) will be provided by the Office upon request and payment of the necessary fee.

FIG. 1 is a front view of a display screen with graphical user interface for ablation generator of our new design; and, FIG. 2 is a front view of a second embodiment thereof.

In the drawings, the broken lines are for the purpose of illustrating the display screen and environment and form no part of the claimed design.

(56) **References Cited**

U.S. PATENT DOCUMENTS

3,650,277 A 3/1972 Sjostrand et al.
4,658,819 A 4/1987 Harris et al.
5,035,694 A 7/1991 Kasprzyk et al.
5,255,679 A 10/1993 Imran
5,300,068 A 4/1994 Rosar et al.

(Continued)

1 Claim, 2 Drawing Sheets
(1 of 2 Drawing Sheet(s) Filed in Color)

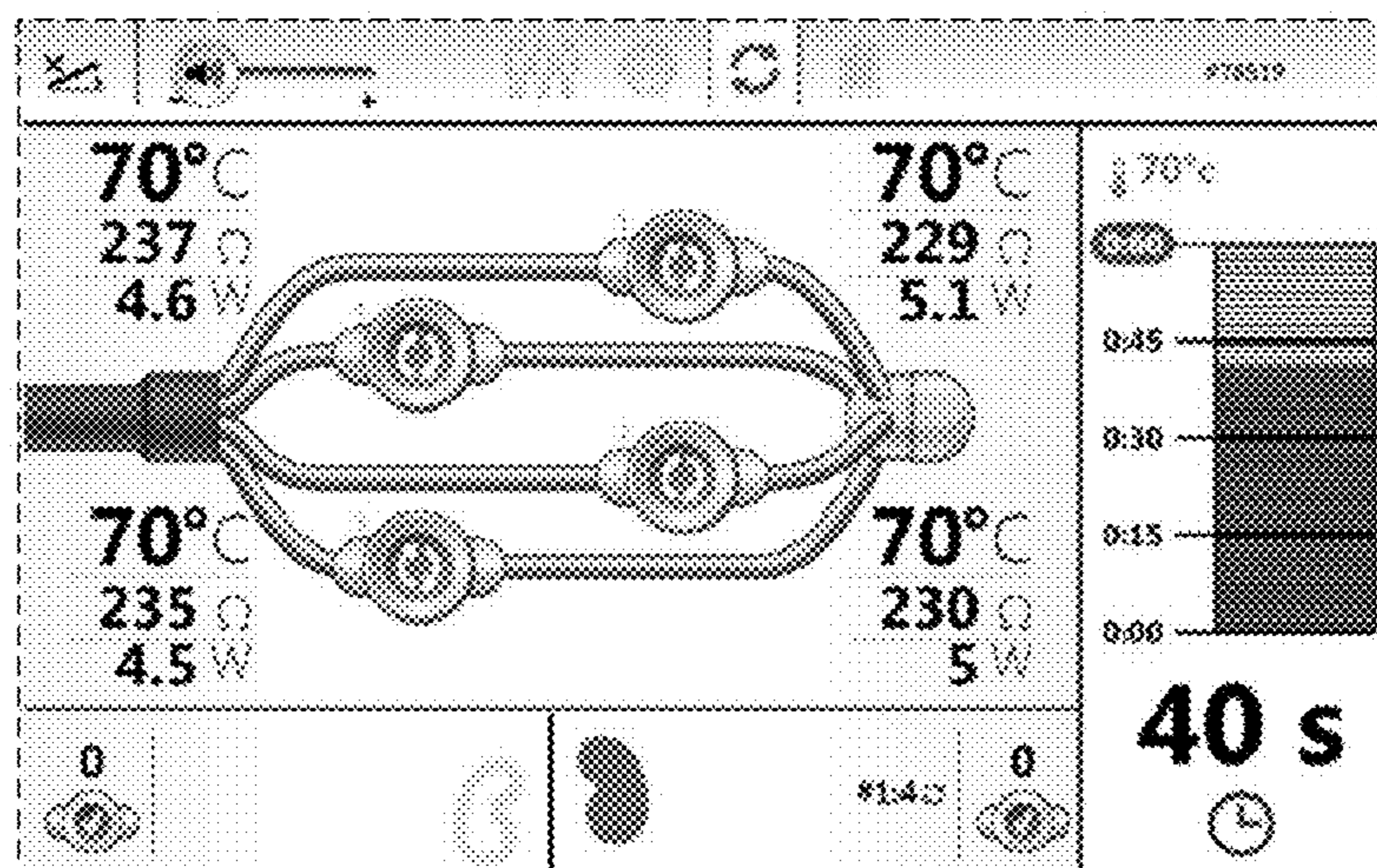

(56)

References Cited

U.S. PATENT DOCUMENTS

5,368,591 A	11/1994	Lennox et al.	D714,336 S *	9/2014	Cojuangco	D14/486
5,387,233 A	2/1995	Alferness et al.	D715,823 S *	10/2014	Molaro	D14/486
5,465,717 A	11/1995	Imran et al.	D715,824 S *	10/2014	Molaro	D14/486
5,531,779 A	7/1996	Dahl et al.	D717,328 S *	11/2014	Lin	D14/486
5,598,848 A	2/1997	Swanson et al.	9,022,948 B2	5/2015	Wang	
5,607,462 A	3/1997	Imran	9,211,096 B2 *	12/2015	Tremper	A61B 5/743
5,628,313 A	5/1997	Webster, Jr.	2002/0068885 A1	6/2002	Harhen et al.	
5,676,662 A	10/1997	Fleischhacker et al.	2002/0120304 A1	8/2002	Mest	
5,707,400 A	1/1998	Terry, Jr. et al.	2003/0050681 A1	3/2003	Pianca et al.	
5,769,077 A	6/1998	Lindegren	2003/0060858 A1	3/2003	Kieval et al.	
5,772,590 A	6/1998	Webster, Jr.	2003/0074039 A1	4/2003	Puskas	
5,893,885 A	4/1999	Webster, Jr.	2003/0114739 A1	6/2003	Fuimaono et al.	
5,897,553 A	4/1999	Mulier et al.	2003/0200120 A1 *	10/2003	Binkert	G06F 19/321 705/3
5,954,649 A	9/1999	Chia et al.	2003/0216792 A1	11/2003	Levin et al.	
5,954,719 A	9/1999	Chen et al.	2003/0233099 A1	12/2003	Danaek et al.	
6,004,269 A	12/1999	Crowley et al.	2004/0215186 A1	10/2004	Cornelius et al.	
6,012,457 A	1/2000	Lesh	2005/0134609 A1 *	6/2005	Yu	G06F 19/3406 345/629
6,016,437 A	1/2000	Tu et al.	2005/0288730 A1	12/2005	Deem et al.	
6,024,740 A	2/2000	Lesh et al.	2006/0089678 A1	4/2006	Shalev	
6,073,048 A	6/2000	Kieval et al.	2007/0135875 A1	6/2007	Demarais et al.	
6,096,037 A	8/2000	Mulier et al.	2007/0138069 A1 *	6/2007	Roncadi	A61M 1/16 210/96.2
6,117,101 A	9/2000	Diederich et al.	2007/0213662 A1 *	9/2007	Kalafut	A61M 5/14546 604/96.01
6,161,543 A	12/2000	Cox et al.	2008/0255478 A1	10/2008	Burdette	
6,178,349 B1	1/2001	Kieval	2009/0076409 A1	3/2009	Wu et al.	
6,200,312 B1	3/2001	Zikorus et al.	2009/0149743 A1 *	6/2009	Barron	A61M 5/007 600/431
6,216,044 B1	4/2001	Kordis	2009/0287271 A1 *	11/2009	Blum	A61N 1/37247 607/45
6,233,491 B1	5/2001	Kordis et al.	2010/0016762 A1	1/2010	Thapliyal et al.	
6,283,951 B1	9/2001	Flaherty et al.	2010/0094209 A1	4/2010	Drasler et al.	
6,287,608 B1	9/2001	Levin et al.	2010/0168737 A1	7/2010	Grunewald	
6,292,695 B1	9/2001	Webster, Jr. et al.	2010/0249773 A1	9/2010	Clark et al.	
6,322,559 B1	11/2001	Daulton et al.	2010/0268307 A1	10/2010	Demarais et al.	
6,460,545 B2	10/2002	Kordis	2010/0286684 A1	11/2010	Hata et al.	
6,522,926 B1	2/2003	Kieval et al.	2011/0004087 A1	1/2011	Fish et al.	
6,613,045 B1	9/2003	Laufer et al.	2011/0087117 A1 *	4/2011	Tremper	A61B 5/02055 600/508
6,616,624 B1	9/2003	Kieval	2011/0118726 A1	5/2011	de la Rama et al.	
6,635,054 B2	10/2003	Fjield et al.	2011/0137298 A1	6/2011	Nguyen et al.	
6,656,174 B1	12/2003	Hegde et al.	2011/0160720 A1	6/2011	Johnson	
6,669,655 B1	12/2003	Acker et al.	2011/0172564 A1 *	7/2011	Drew	A61B 5/061 600/587
6,699,231 B1	3/2004	Sterman et al.	2011/0208048 A1 *	8/2011	Arima	A61B 6/465 600/436
6,748,255 B2	6/2004	Fuimaono et al.	2011/0213231 A1	9/2011	Hall et al.	
6,805,131 B2	10/2004	Kordis	2011/0257641 A1	10/2011	Hastings et al.	
6,845,267 B2	1/2005	Harrison et al.	2011/0264011 A1	10/2011	Wu et al.	
6,954,977 B2	10/2005	Maguire et al.	2011/0264086 A1	10/2011	Ingle	
6,970,730 B2	11/2005	Fuimaono et al.	2012/0143097 A1	6/2012	Pike, Jr.	
7,122,031 B2	10/2006	Edwards et al.	2012/0143298 A1	6/2012	Just et al.	
7,149,574 B2	12/2006	Yun et al.	2012/0296232 A1	11/2012	Ng	
7,155,284 B1	12/2006	Whitehurst et al.	2012/0306881 A1 *	12/2012	Nemoto	A61M 5/14546 345/440
7,162,303 B2	1/2007	Levin et al.	2012/0323233 A1	12/2012	Maguire et al.	
7,245,955 B2	7/2007	Rashidi	2013/0094996 A1 *	4/2013	Janssenswillen ...	G06F 19/3406 422/45
7,291,146 B2	11/2007	Steinke et al.	2013/0116737 A1	5/2013	Edwards et al.	
7,363,076 B2	4/2008	Yun et al.	2013/0131743 A1	5/2013	Yamasaki et al.	
7,419,486 B2	9/2008	Kampa	2013/0144251 A1	6/2013	Sobotka	
7,465,288 B2	12/2008	Dudney et al.	2013/0158363 A1 *	6/2013	Zoghbi	A61B 5/01 600/301
7,468,062 B2	12/2008	Oral et al.	2013/0172715 A1	7/2013	Just et al.	
7,481,803 B2	1/2009	Kesten et al.	2013/0190717 A1 *	7/2013	Dollar	A61M 5/172 604/505
D589,054 S *	3/2009	Koursoumidis	2013/0253348 A1 *	9/2013	Tremper	A61B 5/02055 600/508
D589,969 S *	4/2009	Shibata	2013/0262730 A1 *	10/2013	Al-Ali	A61M 16/0051 710/303
D608,788 S *	1/2010	Meziere	2013/0275145 A1 *	10/2013	Moore	G06F 19/3418 705/2
7,653,438 B2	1/2010	Deem et al.	2014/0067006 A1 *	3/2014	Kaula	A61N 1/37247 607/46
D614,634 S *	4/2010	Nilsen	2014/0093154 A1 *	4/2014	Penenberg	G06F 19/321 382/132
7,717,948 B2	5/2010	Demarais et al.				
7,742,795 B2	6/2010	Stone et al.				
D619,608 S *	7/2010	Meziere				
D619,609 S *	7/2010	Meziere				
7,850,685 B2	12/2010	Kunis et al.				
D635,581 S *	4/2011	Blike				
7,949,407 B2	5/2011	Kaplan et al.				
8,145,316 B2	3/2012	Deem et al.				
8,224,416 B2	7/2012	de La Rama et al.				
D673,967 S *	1/2013	Pearcy				
8,343,213 B2	1/2013	Salahieh et al.				
8,347,891 B2	1/2013	Demarais et al.				
8,442,639 B2	5/2013	Walker et al.				
8,454,594 B2	6/2013	Demarais et al.				
8,545,495 B2	10/2013	Scheib				

(56)

References Cited

U.S. PATENT DOCUMENTS

2014/0282181	A1*	9/2014	Declerck	A61B 5/7445 715/771
2014/0330266	A1*	11/2014	Thompson	A61B 18/1206 606/34
2015/0254413	A1*	9/2015	Soederstroem	G06F 3/04847 715/771
2015/0290407	A1*	10/2015	Bonassa	A61M 16/0066 700/90
2015/0331995	A1*	11/2015	Zhao	G06F 19/321 705/2
2015/0351836	A1*	12/2015	Prutchi	A61B 18/1492 606/41
2016/0000329	A1*	1/2016	Kircher	G01N 21/65 600/431

FOREIGN PATENT DOCUMENTS

WO	01/00273	1/2001
WO	01/22897	4/2001
WO	02/26314	4/2002
WO	03/082080	10/2003
WO	2006/041881	4/2006
WO	2007/149970	12/2007
WO	2008/141150	11/2008
WO	2008/151001	12/2008
WO	2012/064818	5/2012
WO	2012/106492	8/2012

OTHER PUBLICATIONS

Jain, Mudit K. et al, A Three-Dimensional Finite Element Model of Radiofrequency Ablation with Blood Flow and Its Experimental Validation, *Annals of Biomedical Engineering*, vol. 28, pp. 1075-1084, 2000.

Jais, Pierre et al, Efficacy and Safety of Septal and Left-Atrial Linear Ablation for Atrial Fibrillation, *The American Journal of Cardiology*, vol. 84 (9A), Nov. 1999, 139R-146R.

Janssen, Ben J.A. et al, Frequency-Dependent Modulation of Renal Blood Flow by Renal Nerve Activity in Conscious Rabbits, *American Journal of Physiology*, 1997, 273:R597-R608.

Janssen, Ben J.A. et al, Renal Nerves in Hypertension, *Miner Electrolyte Metab* 1989;15:74-82.

Jin, Yu et al, No Support for Renal Denervation in a Meta-Analysis, *JACC* vol. 62, No. 21, 2013 Correspondence Nov. 19-26, 2013:2029-30.

Kaltenbach, Benjamin et al, Renal Artery Stenosis After Renal Sympathetic Denervation, *J Am Coll Cardiol*. Dec. 25, 2012;60(25):2694-5.

Kaltenbach, Benjamin et al, Renal Sympathetic Denervation as Second-Line Therapy in Mild Resistant Hypertension: A Pilot Study, *Catheterization and Cardiovascular Interventions* 81:335-339 (2013).

Kamiya, Atsunori et al, Parallel Resetting of Arterial Baroreflex Control of Renal and Cardiac Sympathetic Nerve Activities During Upright Tilt in Rabbits, *Am J Physiol Heart Circ Physiol* 298: H1966-H1975, 2010.

Kandzari, David E. et al, Catheter-Based Renal Denervation for Resistant Hypertension: Rationale and Design of the Symplicity HTN-3 Trial, *Clin. Cardiol.* 35, 9, 528-535 (2012).

Kapural, Leonardo et al, Radiofrequency Ablation for Chronic Pain Control, *Current Pain and Headache Reports* 2001, 5:517-525.

Kassab, Salah et al, Renal Denervation Attenuates the Sodium Retention and Hypertension Associated with Obesity, *Hypertension* vol. 25, No. 4, Part 2 Apr. 1995.

Katholi, Richard E. et al, Decrease in Peripheral Sympathetic Nervous System Activity following Renal Denervation or Unclipping in the One-Kidney One-Clip Goldblatt Hypertensive Rat, *The Journal of Clinical Investigation*, Jan. 1982;69(1):55-62.

Katholi, Richard E. et al, Role of the Renal Nerves in the Pathogenesis of One-Kidney Renal Hypertension in the Rat, *Hypertension*. 1981;3:404-409.

Katholi, Richard E. et al, The Role of Renal Sympathetic Nerves in Hypertension: Has Percutaneous Renal Denervation Refocused Attention on Their Clinical Significance?; *Progress in Cardiovascular Disease* 52 (2009) 243-248.

Katritsis Demosthenes et al, Recurrence of Left Atrium-Pulmonary Vein Conduction Following Successful Disconnection in Asymptomatic Patients, *Europace* (2004) 6, 425e432.

Killip III, Thomas, Oscillation of Blood Flow and Vascular Resistance During Mayer Waves, *Circulation Research*, vol. XI, Dec. 1962, 987-993.

Kingwell, Bronwyn A. et al, Assessment of Gain of Tachycardia and Bradycardia Responses of Cardiac Baroreflex, *Am J Physiol Heart Circ Physiol* 260:H1254-H1263, 1991.

Kirchheim, H. et al, Sympathetic Modulation of Renal Hemodynamics, Renin Release and Sodium Excretion, *Klin Wochenschr* (1989) 67: 858-864.

Klein, GE et al, Endovascular Treatment of Renal Artery Aneurysms with Conventional Non-Detachable Microcoils and Guglielmi Detachable Coils, *Br J Urol*. Jun. 1997; 79(6):852-860.

Knight, Eric L. et al, Predictors of Decreased Renal Function in Patients with Heart Failure During Angiotensin-Converting Enzyme Inhibitor Therapy: Results from the Studies of Left Ventricular Dysfunction (SOLVD), *American Heart Journal*, vol. 138, No. 5, Part 1, Nov. 1999, 849-855.

Koepke, John P. et al, Functions of the Renal Nerves, *The Physiologist*, vol. 28, No. 1, Feb. 1985, 47-52.

Kompanowska-Jeziarska, Elzbieta et al, Early Effects of Renal Denervation in the Anaesthetised Rat: Natriuresis and Increased Cortical Blood Flow, *Journal of Physiology* (2001), 531.2, pp. 527-534.

Krum, Henry et al, Catheter-Based Renal Sympathetic Denervation for Resistant Hypertension: A Multicentre Safety and Proof-of-Principle Cohort Study, *www.thelancet.com* vol. 373 Apr. 11, 2009 1275-1281.

Krum, Henry et al, Device-Based Antihypertensive Therapy: Therapeutic Modulation of the Autonomic Nervous System, *Circulation*. 2011;123:209-215.

La Grange, Ronald G. et al, Selective Stimulation of Renal Nerves in the Anesthetized Dog: Effect on Renin Release During Controlled Changes in Renal Hemodynamics, *Circulation Research*, *Journal of The American Heart Association*, 1973;33:704-712.

Labeit, Alexander Michael et al, Changes in the Prevalence, Treatment and Control of Hypertension in Germany? A Clinical-Epidemiological Study of 50.000 Primary Care Patients, *PLOS ONE*, Dec. 2012, vol. 7, Issue 12, e52229, 1-11.

Labonte, Sylvain, Numerical Model for Radio-Frequency Ablation of the Endocardium and its Experimental Validation, *IEEE Transactions on Biomedical Engineering*, vol. 41, No. 2. Feb. 1994, 108-115.

Lambert, Gavin W. et al, Health-Related Quality of Life After Renal Denervation in Patients With Treatment-Resistant Hypertension, *Hypertension*. 2012;60:1479-1484.

Lee, Sang Joon et al, Ultrasonic Energy in Endoscopic Surgery, *Yonsei Medical Journal*, vol. 40, No. 6, pp. 545-549, 1999.

Leertouwer, Trude C. et al, In-Vitro Validation, with Histology, of Intravascular Ultrasound in Renal Arteries, *Journal of Hypertension* 1999, vol. 17 No. 2, 271-277.

Leishman, A.W.D., Hypertension—Treated and Untreated, *British Medical Journal*, May 1959, 1361-1368.

Leonard, Bridget L. et al, Differential Regulation of the Oscillations in Sympathetic Nerve Activity and Renal Blood Flow Following Volume Expansion, *Autonomic Neuroscience: Basic and Clinical* 83 (2000) 19-28.

Levin, Stephen, Ardian: Succeeding Where Drugs Fail Treating Hypertension in the Cath Lab, *In Vivo: The Business & Medicine Report*, vol. 27, No. 10, Nov. 2009.

Litynski, Grzegorz S., Kurt Semm and the Fight against Skepticism: Endoscopic Hemostasis, Laparoscopic Appendectomy, and Semm's Impact on the "Laparoscopic Revolution", *JSLs*. Jul.-Sep. 1998; 2(3): 309-313.

(56)

References Cited

OTHER PUBLICATIONS

- Lu, David S.K. et al, Effect of Vessel Size on Creation of Hepatic Radiofrequency Lesions in Pigs: Assessment of the "Heat Sink" Effect, *American Journal of Radiology*, 178, Jan. 2002, 47-51.
- Luscher, Thomas F. et al, Renal Nerve Ablation After Symplicity HTN-3: Confused at the Higher Level?; *European Heart Journal*, doi:10.1093/eurheart.ehu195; May 14, 2014.
- Lustgarten, Daniel L. et al, Cryothermal Ablation: Mechanism of Tissue Injury and Current Experience in the Treatment of Tachyarrhythmias, *Progress in Cardiovascular Diseases*, vol. 41, No. 6 (May/Jun.), 1999: pp. 481-498.
- Mahfoud, Felix et al, Expert Consensus Document from the European Society of Cardiology on Catheter-Based Renal Denervation, *European Heart Journal*, Jul. 2013;34(28):2149-57.
- Mancia, Giuseppe et al, Sympathetic Activation in the Pathogenesis of Hypertension and Progression of Organ Damage, *Hypertension Journal of The American Heart Association*, 1999, 34:724-728.
- McGahan, John P. et al, History of Ablation, Tumor Ablation, 2005, pp. 3-16.
- Medtronic, Inc., J.P. Morgan Healthcare Conference, Corrected Transcript, Jan. 13, 2014, Factset:Callstreet, www.callstreet.com.
- Medtronic, Inc., Medtronic Announces U.S. Renal Denervation Pivotal Trial Fails to Meet Primary Efficacy Endpoint While Meeting Primary Safety Endpoint, www.medtronic.com, Jan. 9, 2014.
- Medtronic, Inc., RDN Therapy with the Symplicity Renal Denervation System, Procedure Fact Sheet, www.medtronic.com, 2011.
- Medtronic, Inc., Renal Denervation (RDN) Novel Catheter—based Treatment for Hypertension, Symplicity RDN System Common Q&A, 2011.
- Medtronic, Inc., Scientific Basis Behind Renal Denervation for the Control of Hypertension, Dec. 2012, http://www.icimeeting.com/2012/images/stories/PDF/1448_Wilcox_I_Mon.pdf.
- Mehdirad, Ali et al, Temperature Controlled RF Ablation in Canine Ventricle and Coronary Sinus using 7 Fr or 5 Fr Ablation Electrodes, *PACE*, vol. 21, Jan. 1998, Part II, 316-321.
- Meredith, I T et al, Exercise Training Lowers Resting Renal But Not Cardiac Sympathetic Activity in Humans; *Hypertension Journal of The American Heart Association*, 1991;18:575-582.
- Michaelis, Lawrence L. et al, Effects of Renal Denervation and Renin Depletion on the Renal Responses to Intravascular Volume Expansion, *Ann Surg*. Mar. 1972; 175(3): 424-430.
- Millard, F.C. et al, Renal Embolization for Ablation of Function in Renal Failure and Hypertension, *Postgraduate Medical Journal* (1989) 65, 729-734.
- Dibona, Gerald F., Renal Innervation and Denervation: Lessons from Renal Transplantation Reconsidered, *Artificial Organs*, vol. 11, No. 6, 1987, 457-462.
- Dibona Gerald., Role of the Renal Nerves in Renal Sodium Retention and Edema Formation, *Trans Am Clin Climatol Assoc*. 1990; 101:38-45.
- Dibona, Gerald F., Sympathetic Nervous System and Hypertension, *Hypertension Journal of The American Heart Association*, 2013; 61: 556-560.
- Dibona Gerald F., Sympathetic Nervous System and the Kidney in Hypertension, *Curr Opin Nephrol Hypertens*. Mar. 2002;11(2):197-200.
- Dibona, Gerald F., The Sympathetic Nervous System and Hypertension, *Hypertension Journal of The American Heart Association*, Vo. 43, Feb. 2004, 147-150.
- Doumas, Michael et al, Interventional Management of Resistant Hypertension, *The Lancet*, vol. 373, Apr. 11, 2009, pp. 1228-1230.
- Dubuc, Marc et al, Feasibility of Cardiac Cryoablation Using a Transvenous Steerable Electrode Catheter, *Journal of Interventional Cardiac Electrophysiology*, 1998, 2: 285-292.
- Elmula, Fadl et al, Renal Sympathetic Denervation in Patients With Treatment-Resistant Hypertension After Witnessed Intake of Medication Before Qualifying Ambulatory Blood Pressure, *Hypertension*. 2013;62:526-532.
- Esler, M. et al, Sympathetic Nerve Activity and Neurotransmitter Release in Humans: Translation from Pathophysiology into Clinical Practice, *Scandinavian Physiological Society*, 2003, 177, 275-284.
- Esler, Murray D. et al, Renal Sympathetic Denervation in Patients with Treatment-Resistant Hypertension (The Symplicity HTN-2 Trial): A Randomised Controlled Trial, *Lancet*, 2010; 376:1903-1909.
- Esler, Murray et al, Assessment of Human Sympathetic Nervous System Activity from Measurements of Norepinephrine Turnover, *Hypertension Journal of The American Heart Association*, vol. 11, No. 1, Jan. 1988, 3-20.
- Evelyn, Kenneth A. et al, Effect of Thoracolumbar Sympathectomy on the Clinical Course of Primary (Essential) Hypertension, *American Journal of Medicine*, Feb. 1960, 188-221.
- Freyberg, R. H. et al, The Effect on the Kidney of Bilateral Splanchnicectomy in Patients with Hypertension, *The Journal of Clinical Investigation*, vol. 16, Issue 1, Jan. 1937, 49-65.
- Gafoor, Sameer et al, Nonresponders to Renal Denervation for Resistant Hypertension, *Endovascular Today*, Oct. 2013, 63-70.
- Garel, L. et al, Fatal Outcome After Ethanol Renal Ablation in Child with End-Stage Kidneys; *AJR* 146:593-594, Mar. 1986.
- Gazdar, A. F. et al, Neural Degeneration and Regeneration in Human Renal Transplants, *The New England Journal of Medicine*, vol. 238, No. 5, Jul. 1970, 222-224.
- Goldberg, Michael R. et al, Reconstructive Vascular Surgery for Renovascular Hypertension, *Can Med Assoc J*. Feb. 2, 1974;110(3):275-80.
- Golwyn, Daniel H. et al, Percutaneous Transcatheter Renal Ablation with Absolute Ethanol for Uncontrolled Hypertension or Nephrotic Syndrome: Results in 11 Patients with End-Stage Renal Disease, *Journal of Vascular and Interventional Radiology*, Jul.-Aug. 1997, vol. 8, No. 4, 527-533.
- Gorisch, Wolfram et al, Heat-Induced Contraction of Blood Vessels, *Lasers in Surgery and Medicine* 2:I-13 (1982).
- Grassi, Guido et al, Baroreflex Control of Sympathetic Nerve Activity in Essential and Secondary Hypertension, *Hypertension Journal of The American Heart Association*, 1998;31:68-72.
- Grassi, Guido et al, Dissociation Between Muscle and Skin Sympathetic Nerve Activity in Essential Hypertension, Obesity, and Congestive Heart Failure, *Hypertension*. 1998;31:64-67.
- Grimson, Keith S. et al, Results of Treatment of Patients with Hypertension by Total Thoracic and Partial to Total Lumbar Sympathectomy, Splanchnicectomy and Celiac Ganglionectomy, *Annals of Surgery*, Jun. 1949, vol. 129, No. 6, 850-871.
- Grimson, Keith S. et al, Total Thoracic and Partial to Total Lumbar Sympathectomy, Splanchnicectomy and Celiac Ganglionectomy for Hypertension, *Annals of Surgery*, Oct. 1953, vol. 138, No. 4, 532-547.
- Grimson Keith S., Total Thoracic and Partial to Total Lumbar Sympathectomy and Celiac Ganglionectomy in the Treatment of Hypertension; *Annals of surgery*, Oct. 194, vol. 114, No. 4, 753-775.
- Guyton, Arthur C., Blood Pressure Control Special Role of the Kidneys and Body Fluids, *Science*, vol. 252, Jun. 1991, 1813-1816.
- Hafkenschiel, Joseph H. et al, Primary Hypertension Survey of the Survival of Patients with Established Diastolic Hypertension After Ten Years of Medical and Surgical Treatment, *The American Journal of Cardiology*, vol. 16, Jul. 1965, 61-66.
- Hafkenschiel, Joseph H. et al, The Surgical Treatment of Hypertension with Particular Reference to Adrenalectomy and Sympathectomy, *Transactions. American College of Cardiology*, vol. 5, Dec. 1955, pp. 107-112.
- Hall J.E. et al, Role of Sympathetic Nervous System and Neuropeptides in Obesity Hypertension, *Brazilian Journal of Medical and Biological Research*, 2000,33:605-618.
- Hall, John E., The Kidney, Hypertension, and Obesity, *Hypertension*. 2003;41:625-633.
- Hall, Wintrop H. et al, Combined Embolization and Percutaneous Radiofrequency Ablation of a Solid Renal Tumor, *American Journal of Roentgenology*, 174, Jun. 2000, 1592-1594.
- Hamm, Christian et al, *Confluence*, Issue eight, Apr. 2014.
- Han, Young-Min et al, Renal Artery Embolization with Diluted Hot Contrast Medium: An Experimental Study, *Journal of Vascular and Interventional Radiology*, Jul. 2001;12(7):862-868.

(56)

References Cited

OTHER PUBLICATIONS

- Hansen, Jesper Melchoir et al, The Transplanted Human Kidney Does Not Achieve Functional Reinnervation, *Clinical Science*, (1994) 87, 13-20.
- Heuer, George J., The Surgical Treatment of Essential Hypertension, *Annals of Surgery*, Oct. 1936, vol. 104, No. 3, 771-786.
- Hintona, J. William, End Results of Thoracolumbar Sympathectomy for Advanced Essential Hypertension, *The Bulletin*, Apr. 1948, 239-252.
- Holmer, Stephan et al, Role of Renal Nerves for the Expression of Renin in Adult Rat Kidney, *The American Journal of Physiology*, May 1994;266(5 Pt 2):F738-F745.
- Hoobler, S.W. et al, The Effects of Splanchnicectomy on the Blood Pressure in Hypertension, *Circulation Journal of The American Heart Association*, vol. IV, Aug. 1951, 173-183.
- Hoppe, Uta C. et al, Minimally Invasive System for Baroreflex Activation Therapy Chronically Lowers Blood Pressure with Pacer-maker-like Safety Profile: Results from the Barostim Neo Ttrial, *J Am Soc Hypertens*. Jul.-Aug. 2012;6(4):270-6.
- Howard, James P. et al, Size of Blood Pressure Reduction from Renal Denervation: Insights from Meta-Analysis of Antihypertensive Drug Trials of 4121 Patients with Focus on Trial Design: The Converge Report, *Heart* 2013;0:1-9.
- Howard, James P. et al, Unintentional Overestimation of an Expected Antihypertensive Effect in Drug and Device Trials: Mechanisms and Solutions, *International Journal of Cardiology*, vol. 172, Issue 1, Mar. 1, 2014, pp. 29-35.
- Howell, Marcus H. et al, Tandem Stenting of Crossed Renal Arteries with Ostial Stenosis, *Tex Heart Inst J*. 2000;27(2): 166-169.
- Hoye, Neil A. et al, Endovascular Renal Denervation: A Novel Sympatholytic with Relevance to Chronic Kidney Disease, *Clinical Kidney Journal Advance Access*, (2013) 0:1-8.
- Huang, Shoeni K. Stephen et al, Radiofrequency Catheter Ablation of Cardiac Arrhythmias, *Basic Concepts and Clinical Applications*, Wiley-Blackwell, Jun. 2000, 1-12.
- Huang, Wann-Chu, Renal Denervation Prevents and Reverses Hyperinsulinemia-Induced Hypertension in Rats, *Hypertension Journal of The American Heart Association*, 1998;32:249-254.
- Humphreys, Michael H., Renal Nerves and CKD: Is Renal Denervation the Answer?, *Journal of The American Society of Nephrology*, 2012, 23: 1-3.
- International Search Report and Written Opinion for Application No. PCT/US2010/054637 mailed Jan. 3, 2011.
- International Search Report and Written Opinion for Application No. PCT/US2010/054684 mailed Jan. 10, 2011.
- Irigoyen, M.C.C. et al, Baroreflex Control of Sympathetic Activity in Experimental Hypertension, *Brazilian Journal of Medical and Biological Research*, (1998) 31: 1213-1220.
- Izzo, Jr, Joseph L. et al, The Sympathetic Nervous System and Baroreflexes in Hypertension and Hypotension, *Current Hypertension Reports* 1999, 3:254-263.
- Jackman, Warren M. et al, Catheter Ablation of Arrhythmias, Proposed Anatomy and Catheter Ablation of Epicardial Posteroseptal and Left Posterior Accessory AV Pathways (Chapter 16), 2002, Futura Publishing Company, Inc., 321-343.
- Abboud, Francois M., The Sympathetic System in Hypertension, State-of-the-Art Review, *Hypertension Journal of the American Heart Association*, Hypertension 4 (suppl II): II-208-II-225, 1982.
- Allen, Edgar V., Sympathectomy for Essential Hypertension, *Circulation Journal of the American Heart Association*, vol. VI, Jul. 1952, 131-140.
- Anderson, Erling A. et al, Elevated Sympathetic Nerve Activity in Borderline Hypertensive Humans, Evidence From Direct Intraneural Recordings, *Hypertension Journal of the American Heart Association*, vol. 14, No. 2, Aug. 1989, 177-183.
- Ardian, Inc., Ardian(R) Receives 2010 EuroPCR Innovation Award and Demonstrates Further Durability of Renal Denervation Treatment for Hypertension, *PR Newswire*, Jun. 3, 2010.
- Arentz, Thomas et al, Feasibility and Safety of Pulmonary Vein Isolation Using a New Mapping and Navigation System in Patients with Refractory Atrial Fibrillation, *Circulation Journal of the American Heart Association*, Nov. 18, 2003, 2484-2490.
- Badoer, Emilio et al, Cardiac Afferents Play the Dominant Role in Renal Nerve Inhibition Elicited by Volume Expansion in the Rabbit, *American Journal of Physiology*, 1998, R383-R388.
- Bakris, George L. et al, Baroreflex Activation Therapy Provides Durable Benefit in Patients with Resistant Hypertension: Results of Long-Term Follow-up in the Rheos Pivotal Trial, *J Am Soc Hypertens*. Mar.-Apr. 2012;6(2):152-8.
- Bao, Gang et al, Blood Pressure Response to Chronic Episodic Hypoxia: Role of the Sympathetic Nervous System, *American Journal of Physiology*, 1997, 95-101.
- Barajas, Luciano et al, Anatomy of the Renal Innervation: Intrarenal Aspects and Ganglia of Origin, *Canadian Journal of Physiology and Pharmacology*, vol. 70, No. 5, May 1992, 735-749.
- Barajas, Luciano et al, Monoaminergic Innervation of the Rat Kidney: A Quantitative Study, *American Journal of Physiology*, vol. 259, No. 3, Sep. 1990, F503-F511.
- Bardram, Linda et al, Late Results After Surgical Treatment of Renovascular Hypertension, A Follow-up Study of 122 Patients 2-18 Years After Surgery, *Annals of Surgery*, vol. 201, No. 2, Feb. 1985, 219-224.
- Bello-Reuss, Elsa et al, Effect of Renal Sympathetic Nerve Stimulation on Proximal Water and Sodium Reabsorption, *The Journal of Clinical Investigation*, vol. 57, Apr. 1976, 1104-1107.
- Bello-Reuss, Elsa et al, Effects of Acute Unilateral Renal Denervation in the Rat, *The Journal of Clinical Investigation*, vol. 56, Jul. 1975, 208-217.
- Benito, Fernando et al, Radiofrequency Catheter Ablation of Accessory Pathways in Infants, *Heart*, 1997, 78, 160-162.
- Bernardi, Luciano et al, Influence of Type of Surgery on the Occurrence of Parasympathetic Reinnervation After Cardiac Transplantation, *Circulation Journal of the American Heart Association*, Apr. 14, 1998;97(14):1368-74.
- Bertog, Stefan C. et al, Renal Denervation for Hypertension, *JACC: Cardiovascular Interventions*, vol. 5, No. 3, Mar. 2012, 249-258.
- Bertram, Harald et al, Coronary Artery Stenosis After Radiofrequency Catheter Ablation of Accessory Atrioventricular Pathways in Children with Ebstein's Malformation, *Circulation Journal of the American Heart Association*, 2001, 538-543.
- Blankestijn, Peter J. et al, Renal Denervation: Potential Impact on Hypertension in Kidney Disease?, *Nephrol Dial Transplant* (2011) 0: 1-3.
- Blankestijn, Peter J. et al, Sympathetic Overactivity in Renal Failure Controlled by ACE Inhibition: Clinical Significance, *Nephrol Dial Transplant*, 2000, 15, 755-758.
- Blum, Ulrich et al, Treatment of Ostial Renal-Artery Stenoses with Vascular Endoprostheses After Unsuccessful Balloon Angioplasty, *The New England Journal of Medicine*, vol. 336, No. 7, Feb. 1997, 459-465.
- Brinkmann, Julia et al, Catheter-Based Renal Nerve Ablation and Centrally Generated Sympathetic Activity in Difficult-to-Control Hypertensive Patients Prospective Case Series, *Hypertension*. 2012;60:1485-1490.
- Brookes, Linda et al, Renal Denervation: Is Reality Meeting Expectations?, An Interview with Michel Azizi, MD, PhD, *Medscape*, Jan. 7, 2013.
- Bunte, Matthew C. et al, Endovascular Treatment of Resistant and Uncontrolled Hypertension, *JACC: Cardiovascular Interventions*, vol. 6, No. 1, 2013, 1-9.
- Calleary, Hickey D. et al, Pre-Transplant Bilateral Native Nephrectomy for Medically Refractory Hypertension, *The Irish Medical Journal*, Jul.-Aug. 2001;94(7):214-6.
- Callens, David J. et al, Narrowing of the Superior Vena Cava-Right Atrium Junction During Radiofrequency Catheter Ablation for Inappropriate Sinus Tachycardia: Analysis with Intracardiac Echocardiography, *Journal of the American College of Cardiology*, vol. 33, No. 6, 1999, 1667-1670.
- Campese, V.M., Is Hypertension in Chronic Renal Failure Neurogenic in Nature?, *Nephrol Dial Transplant*, 1994, 9: 741-742.
- Campese, Vito M. et al, Neurogenic Factors in Renal Hypertension, *Current Hypertension Reports*, 2002 4: 256-260.

(56)

References Cited

OTHER PUBLICATIONS

- Campese, Vito M. et al, Renal Afferent Denervation Prevents Hypertension in Rats With Chronic Renal Failure, *Hypertension*, 1995, 25, 878-882.
- Campese, Vito M. et al, Renal Afferent Denervation Prevents the Progression of Renal Disease in the Renal Ablation Model of Chronic Renal Failure in Rat, *American Journal of Kidney Disease*, vol. 26, No. 5, Nov. 1995, 861-865.
- Campese, Vito M., Interventional Hypertension: A New Hope or a New Hype? The Need to Redefine Resistant Hypertension, *J Hypertens*. Nov. 2013;31(11):2118-21.
- Canadian Agency for Drugs and Technologies in Health, Catheter-Based Renal Denervation for Treatment-Resistant Hypertension; Issues in Emerging Health Technologies, Issue 121, Mar. 2013.
- Carlstedt, Thomas et al, Regrowth of Lesioned Dorsal Root Nerve Fibers into the Spinal Cord of Neonatal Rats, *Neuroscience Letters* Feb. 10, 1987;74(1):14-8.
- Chabanier, H. et al, On the Decapsulation and Neurectomy of the Kidney in Permanent Hypertensive States, *The Medical Press*, Feb. 22, 1936, No. 16, 307-310.
- Cicccone, C D et al, Effects of Acute Renal Denervation on Kidney Function in Deoxycorticosterone Acetate-Hypertensive Swine, *Hypertension Journal of the American Heart Association*, Oct. 1986, vol. 8, No. 10, 925-931.
- Ciriello, John et al, Renal Afferents and Hypertension, *Current Hypertension Reports* 2002, 4:136-142.
- Converse, Richard L. et al, Sympathetic Overactivity in Patients with Chronic Renal Failure, *The New England Journal of Medicine*, vol. 327, No. 27, 1992, 1912-1918.
- Crile, George, The Clinical Results of Celiac Ganglionectomy in the Treatment of Essential Hypertension, *Annals of Surgery*, Jun 1938; 107(6): 909-916.
- Cruickshank, J.M., Beta-Blockers Continue to Surprise Us, *European Heart Journal* (2000) 21, 354-364.
- Curtis, John J. et al, Surgical Therapy for Persistent Hypertension After Renal Transplantation, *Transplantation*, vol. 31, No. 2, 1981, 125-128.
- Dailey, U.G., Surgical Treatment of Hypertension: A Review-Part II, *Journal of the National Medical Association*, May 1948, vol. 40, No. 3., 113-116.
- Dailey, U.G., Surgical Treatment of Hypertension: A Review-Part III, *Journal of the National Medical Association*, Jul. 1948, vol. 40, No. 4, 160-162.
- Dailey, U.G., The Surgical Treatment of Hypertension: A Review, *Journal of the National Medical Association*, Mar. 1948, vol. 40, No. 2, 76-79.
- Davis, Mark I. et al, Effectiveness of Renal Denervation Therapy for Resistant Hypertension A Systematic Review and Meta-Analysis, *Journal of the American College of Cardiology*, vol. 62, No. 3, 2013, 231-241.
- De Wardener, H.E., The Hypothalamus and Hypertension, *Physiological Reviews*, vol. 81, No. 4, Oct. 2001.
- Dequattro V. et al. The Sympathetic Nervous System: The Muse of Primary Hypertension, *Journal of Human Hypertension*, 2002, 16 (Supp 1) S64-S69.
- Dibona, Gerald F. et al, Neural Control of Renal Function, *Physiological Reviews*, vol. 77, No. 1, Jan. 1997, 75-197.
- Dibona, Gerald F. et al, Translational Medicine: The Antihypertensive Effect of Renal Denervation, *American Journal of Physiology*, 2010, 298, R245-R253.
- Dibona, Gerald F., Neural Control of Renal Function: Cardiovascular Implications, *Hypertension Journal of The American Heart Association*, vol. 13, No. 6, Part 1, Jun. 1989, 539-548.
- Dibona, Gerald F., Neural Control of the Kidney: Functionally Specific Renal Sympathetic Nerve Fibers, *American Journal of Physiology*, 2000, 279, R1517-R1524.
- Dibona, Gerald F., Neural Control of the Kidney: Past, Present, and Future, *Hypertension Journal of The American Heart Association*, vol. 41, Mar. 2003, Part II, 621-624.
- Moak, Jeffrey P. et al, Case Report: Pulmonary Vein Stenosis Following RF Ablation of Paroxysmal Atrial Fibrillation: Successful Treatment with Balloon Dilation, *Journal of Interventional Cardiac Electrophysiology*, Dec. 4, 2000, 4:621-631.
- Mogil, Robert A. et al, Renal Innervation and Renin Activity in Salt Metabolism and Hypertension, *American Journal of Physiology*, vol. 216, No. 4, Apr. 1969, 693-697.
- Morita, Hironobu et al, Neural Control of Urinary Sodium Excretion During Hypertonic NaCl Load in Conscious Rabbits: Role of Renal and Hepatic Nerves and Baroreceptors, *Journal of the Autonomic Nervous System*, 34 (1991) 157-170.
- Morrissey, D.M. et al, Sympathectomy in the Treatment of Hypertension, *The Lancet*, Feb. 1953, 403-408.
- Mortara, Andrea et al, Nonselective Beta-Adrenergic Blocking Agent, Carvedilol, Improves Arterial Baroreflex Gain and Heart Rate Variability in Patients With Stable Chronic Heart Failure, *Journal of the American College of Cardiology*, vol. 36, No. 5, 2000, 1612-1618.
- Moss, Jonathan, *Interventional Radiology and Renal Denervation, Interventions*, vol. 13, Issue 3, 2013.
- Naghavi, Morteza et al, Thermography Basket Catheter: In Vivo Measurement of the Temperature of Atherosclerotic Plaques for Detection of Vulnerable Plaques, *Catheterization and Cardiovascular Interventions* 59:52-59 (2003).
- Naidoo, N. et al, Thoracic Splanchnic Nerves: Implications for Splanchnic Denervation, *Journal of Anatomy*, Nov. 2001;199(Pt 5):585-590.
- Nakagawa, A. et al, Selective Ablation of Porcine and Rabbit Liver Tissue Using Radiofrequency: Preclinical Study, *European Surgical Research*, 1999;31:371-379.
- Nakagawa, Hiroshi et al, Inverse Relationship Between Electrode Size and Lesion Size During Radiofrequency Ablation With Active Electrode Cooling, *Circulation*. Aug. 4, 1998;98(5):458-465.
- Nanni, Gregg S. et al, Control of Hypertension by Ethanol Renal Ablation, *Radiology* 148: 51-54, Jul. 1983.
- Ndegwa, S., Catheter-Based Renal Denervation for Treatment-Resistant Hypertension [Issues in emerging health technologies issue 121]. Ottawa: Canadian Agency for Drugs and Technologies in Health; 2013.
- Neutel, Joel M., Hypertension and Its Management: A Problem in Need of New Treatment Strategies, *Journal of Renin-Angiotensin-Aldosterone System* 2000 1: S10-S13.
- Newcombe, C.P. et al, Sympathectomy for Hypertension, *British Medical Journal*, Jan. 1959, 142-144.
- Ng, Fu Siong et al, Catheter Ablation of Atrial Fibrillation, *Clinical Cardiology*, 25, 384-394 (2002).
- Norman, Roger A. et al, Role of the Renal Nerves in One-Kidney, One Clip Hypertension in Rats, *Hypertension Journal of The American Heart Association*, 1984;6:622-626.
- Nozawa, Takashi et al, Effects of Long-Term Renal Sympathetic Denervation on Heart Failure After Myocardial Infarction in Rats, *Heart Vessels* (2002) 16:51-56.
- O'Connor, Brian K. et al, Radiofrequency Ablation of a Posteroseptal Accessory Pathway Via the Middle Cardiac Vein in a Six-Year-Old Child, *PACE*, vol. 20, Oct. 1997, Part 1, 2504-2507.
- O'Hagen, Kathleen P. et al, Renal Denervation Decreases Blood Pressure in DOCA-Treated Miniature Swine With Established Hypertension, *American Journal of Hypertension*, 1990; 3:62-64.
- Oliveira, Vera L.L. et al, Renal Denervation Normalizes Pressure and Baroreceptor Reflex in High Renin Hypertension in Conscious Rats, *Hypertension* vol. 19, No. 2 Feb. 1992, Supplement II, II-17-II-21.
- Omran, Heyder et al, Echocardiographic Imaging of Coronary Sinus Diverticula and Middle Cardiac Veins in Patients with Preexcitation Syndrome: Impact—on Radiofrequency Catheter Ablation of Posteroseptal Accessory Pathways, *PACE*, vol. 18, Jun. 1995, 1236-1243.
- Oparil, Suzanne et al, Renal Nerve Ablation: Emerging Role in Therapeutics; *Blood Pressure*, Oct. 2011, vol. 20, No. 5, pp. 253-255.
- Oral, Hakan et al, Pulmonary Vein Isolation for Paroxysmal and Persistent Atrial Fibrillation, *Circulation Journal of The American Heart Association*, 2002;105:1077-1081.

(56)

References Cited

OTHER PUBLICATIONS

- Osborn, Jeffrey L. et al, Long-Term Increases in Renal Sympathetic Nerve Activity and Hypertension, *Clinical and Experimental Pharmacology and Physiology* (1997) 24,72-76.
- Osborn, John W., The Sympathetic Nervous System and Long-Term Regulation of Arterial Pressure: What Are the Critical Questions?, *Clinical and Experimental Pharmacology and Physiology* (1997) 24, 68-71.
- Ou, Baiqing et al, Baroreflex Sensitivity Predicts the Induction of Ventricular Arrhythmias by Cesium Chloride in Rabbits, *Japanese Circulation Journal*, 1999; 63: 783-788.
- Oz, Mehmet, Pressure Relief, *TIME Magazine*, Monday, Jan. 9, 2012.
- Page, Irvine H. et al, Mechanisms, Diagnosis and Treatment of Hypertension of Renal Vascular Origin, *Annals of Internal Medicine*, Aug. 1959, vol. 51, No. 2, 196-211.
- Page, Irvine H. et al, Mechanisms, Diagnosis and Treatment of Hypertension of Renal Vascular Origin; *Annals of Internal Medicine*, Aug. 1959;51:196-211.
- Page, Irvine H. et al, The Effect of Renal Denervation on the Level of Arterial Blood Pressure and Renal Function in Essential Hypertension, *Journal of Clinical Investigation*, 1935;14(1):27-30.
- Page, Irvine H. et al, The Effects of Renal Denervation on Patients Suffering from Nephritis, *J Clin Invest.* 1935;14(4):443-458.
- Page, Irvine H., The Effect of Renal Efficiency of Lowering Arterial Blood Pressure in Cases of Essential Hypertension and Nephritis, *Journal of Clinical Investigation*, Nov. 1934; 13(6): 909-915.
- Page, Max, Section of Surgery, Discussion on the Surgical Treatment of Hypertension, *Proceedings of the Royal Discussion of Medicine*, vol. XLI, Feb. 1948, 359-372.
- Papademetriou, Vasilios, Hypertension and the Simplicity Renal Denervation System, *Scientific Background*, www.medtronic.com, 2011.
- Pappone, Carlo et al, Circumferential Radiofrequency Ablation of Pulmonary Vein Ostia: A New Anatomic Approach for Curing Atrial Fibrillation, *Circulation*, *Journal of The American Heart Association*, 2000;102:2619-2628.
- Parati, Gianfranco et al, The Human Sympathetic Nervous System: Its Relevance in Hypertension and Heart Failure, *European Heart Journal* (2012) 33, 1058-1066.
- Parmar, Arundhati, Analyst: Medtronic Will Likely Acquire Another Hypertension Therapy Firm, *Medcity News*, Apr. 27, 2012; 3:06 p.m.; medcitynews.com.
- Pavlovich Christian P. et al, Percutaneous Radio Requency Ablation of Small Renal Tumors: Initial Results; *The Journal of Urology*, vol. 167, Jan. 10-15, 2002.
- Pearce, John A. et al, Blood Vessel Architectural Features and Their Effect on Thermal Phenomena, *Critical Reviews*, vol. CR75, Bellingham, WA: SPIE Optical Engineering Press; 2000, p. 231-277.
- Peet, Max Minor, Hypertension and Its Surgical Treatment by Bilateral Supradiaphragmatic Splanchnicectomy, *American Journal of Surgery*, vol. 75, Issue 1, Jan. 1948, 48-68.
- Perry, C. Bruce, Malignant Hypertension Cured by Unilateral Nephrectomy, *British Heart Journal*, Jul. 1945; 7(3):139-142.
- Persu Alexandre et al, Renal Denervation: Ultima Ratio or Standard in Treatment-Resistant Hypertension, *Hypertension Journal of The American Heart Association*, Sep. 2012;60(3):596-606.
- Peterson, Helen Hogh et al, Lesion Dimensions During Temperature-Controlled Radiofrequency Catheter Ablation of Left Ventricular Porcine Myocardium Impact of Ablation Site, Electrode Size, and Convective Cooling, *Circulation Journal of The American Heart Association*, 1999;99:319-325.
- Plouin, Pierre-Francois et al, Blood Pressure Outcome of Angioplasty in Atherosclerotic Renal Artery Stenosis A Randomized Trial, *Hypertension Journal of The American Heart Association*, 1998;31:823-829.
- Poutasse, Eugene F., Surgical Treatment of Renal Hypertension, *American Journal of Surgery*, vol. 107, Jan. 1964, 97-103.
- Pugsley, M.K. et al, The Vascular System An Overview of Structure and Function, *Journal of Pharmacological and Toxicological Methods* 44 (2000) 333-340.
- Putney, John Paul, Are Secondary Considerations Still "Secondary"? An Examination of Objective Indicia of Nonobviousness Five Years After KSR, *Intellectual Property Brief*, vol. 4, Issue 2, article 5, 2012, 45-59.
- Ramsay, Lawrence E. et al, Blood Pressure Response to Percutaneous Transluminal Angioplasty for Renovascular Hypertension: An Overview of Published Series; *British Medical Journal* Mar. 3, 1990; 300(6724): 569-572.
- Rippy, Marian K. et al, Catheter-Based Renal Sympathetic Denervation: Chronic Preclinical Evidence for Renal Artery Safety, *Clin Res Cardiol* (2011) 100:1095-1101.
- Ritz, Eberhard, New Approaches to Pathogenesis and Management of Hypertension, *Clin J Am Soc Nephrol* 4: 1886-1891, 2009.
- Zazgornik, Jan et al, Bilateral Nephrectomy: The Best, but Often Overlooked, Treatment for Refractory Hypertension in Hemodialysis Patients, *AJH* 1998; 11:1364-1370.
- Robbins, Ivan M. et al, Pulmonary Vein Stenosis After Catheter Ablation of Atrial Fibrillation, *Circulation Journal of The American Heart Association*, 1998;98:1769-1775.
- Rocha-Singh, Krishna J., Catheter-Based Sympathetic Renal Denervation A Novel Strategy for the Treatment of Resistant Hypertension, *Endovascular Today*, Aug. 2009, 52-56.
- Rocha-Singh, Krishna J., Renal Artery Denervation: A Brave New Frontier, *Endovascular Today*, Feb. 2012, 45-53.
- Sanderson, John E. et al, Effect of B-Blockade on Baroreceptor and Autonomic Function in Heart Failure, *Clinical Science* (1999) 96, 137-146.
- Santos, Mario et al, Renal Sympathetic Denervation in Resistant Hypertension, *World J Cardiol* Apr. 26, 2013; 5(4):94-101.
- Savard, Sebastien et al, Eligibility for Renal Denervation in Patients With Resistant Hypertension When Enthusiasm Meets Reality in Real-Life Patients, *J Am Coll Cardiol*. 2012;60(23):2422-2424.
- Schauerte, Patrick et al, Catheter Ablation of Cardiac Autonomic Nerves for Prevention of Vagal Atrial Fibrillation, *Circulation Journal of The American Heart Association*, 2000, 102:2774-2780.
- Schlaich, Markus P. et al, International Expert Consensus Statement: Percutaneous Transluminal Renal Denervation for the Treatment of Resistant Hypertension, *Journal of the American College of Cardiology* vol. 62, Issue 22, Dec. 3, 2013, pp. 2031-2045.
- Schlaich, Markus P. et al, Renal Denervation as a Therapeutic Approach for Hypertension Novel Implications for an Old Concept, *Hypertension Journal of The American Heart Association*, 2009;54:1195-1201.
- Schlaich, Markus P. et al, Renal Sympathetic-Nerve Ablation for Uncontrolled Hypertension, *The New England Journal of Medicine*, 2009; 361:932-934.
- Schmieder, Roland E. et al, ESH Position Paper: Renal Denervation—An Interventional Therapy of Resistant Hypertension, *Journal of Hypertension*, 2012, 30:837-841.
- Schmieder, Roland E. et al, Updated EHS Position Paper on Interventional Therapy of Resistant Hypertension, *EuroIntervention* 2013; 9:R58-R66.
- Sellers, Alfred M. et al, Adrenalectomy and Sympathectomy for Hypertension Ten Year Survival, *Archives of Surgery*, vol. 89, Nov. 1964, 880-886.
- Sen, S.K., Some Observations on Decapsulation and Denervation of the Kidney, *The British Journal of Urology*, vol. 8, Issue 4, Dec. 1936, 319-328.
- Shiraki, Iwao William, Correction of Renal Hypertension by Ligation of Stenotic Segmental Renal Artery, *Urology*, vol. IX, No. 3, Mar. 1977, 296-298.
- Shonai, Takaharu et al, Renal Artery Aneurysm: Evaluation with Color Doppler Ultrasonography Before and After Percutaneous Transarterial Embolization, *J Ultrasound Med* 19:277-280, 2000.
- Silver, Donald et al, Renovascular Hypertension From Renal Artery Compression by Congenital Bands, *Annals of Surgery*, Feb. 1976, 161-166.
- Smith, Gardner W. et al, Surgical Results and the Diagnostic Evaluation of Renovascular Hypertension, *Annals of Surgery*, May 1968, 669-680.

(56)

References Cited

OTHER PUBLICATIONS

- Smith, Harold P. et al, Radiofrequency Neurolysis in a Clinical Model Neuropathological Correlation, *J Neurosurg* 55:246-253, 1981.
- Smithwick, R.H., An Evaluation of the Surgical Treatment of Hypertension, *The Bulletin*, Nov. 1949; 25(11):698-716.
- Smithwick, Reginald H. et al, Splanchnicectomy for Essential Hypertension, *The Journal of the American Medical Association*, vol. 152, No. 16, Aug. 1953, 1501-1504.
- Solis-Herruzo, J.A. et al, Effects of Lumbar Sympathetic Block on Kidney Function in Cirrhotic Patients with Hepatorenal Syndrome, *Journal of Hepatology*, 1987; 5: 167-173.
- Sowers, James R. et al, Diabetes, Hypertension, and Cardiovascular Disease: An Update, *Hypertension Journal of The American Heart Association*, 2001;37:1053-1059.
- Stanley, James C., Surgical Treatment of Renovascular Hypertension, *The American Journal of Surgery*, vol. 174, Aug. 1997, 102-110.
- Stella, Andrea et al, Effects of Reversible Renal Denervation on Haemodynamic and Excretory Functions of the Ipsilateral and Contralateral Kidney in the Cat, *Journal of Hypertension* 1986, 4: 181-188.
- Stuart, Candace, *Newest Frontier in Cardiac Care: Kidneys*; Cardiovascular Business, Dec. 13, 2012.
- Stuart, Mary, *Masterminds of Ardian: An Interview With Inventors Mark Gelfand and Howard Levin*, *Windhover Information*, Start-Up Jan. 1, 2011.
- Sun, Yingxian et al, Risk of Coronary Stenosis with Venous Ablation for Epicardial Accessory Pathways, *PACE*, Apr. 2001, Part II, vol. 24, 605.
- Swartz, John F. et al, Radiofrequency Endocardial Catheter Ablation of Accessory Atrioventricular Pathway Atrial Insertion Sites, *Circulation Journal of The American Heart Association*, 1993;87:487-499.
- Teigen, Corey L. et al, Segmental Renal Artery Embolization for Treatment of Pediatric Renovascular Hypertension, *Journal of Vascular and Interventional Radiology*, 1992; 3:111-117.
- Teixeira, Maria Do Carmo et al, 1992; Role of the Peripheral Renin Profile in Predicting Blood Pressure Control After Bilateral Nephrectomy in Renal-Transplanted Patients, *Nephrol Dial Transplant* (1998) 13: 2092-2097.
- Teo, W S et al, Radiofrequency Catheter Ablation of Accessory Pathways: The Initial Experience in Singapore, *Singapore Medical Journal*, 1994; vol. 35:36-40.
- Thiebot, J. et al, Bilateral Nephrectomy by Embolization of the Renal Arteries: A Report on Five Cases (author's transl), *Sem Hop.* Apr. 8-15, 1980;56(13-14):670-5.
- Thomas, George et al, Renal Denervation to Treat Resistant Hypertension: Guarded Optimism, *Cleveland Clinic Journal of Medicine*, vol. 79, No. 7, Jul. 2012, 501-510.
- Thomas, Natalie A., Secondary Consideration in Nonobviousness Analysis: The Use of Objective Indicia Following *KSR V. Teleflex*, *NYU Law Review*, vol. 86, No. 6, Dec. 2011, 2070-2112.
- Ting, Chih-Tai et al, Arterial Hemodynamics in Human Hypertension Effects of Angiotensin Converting Enzyme Inhibition, *Hypertension Journal of The American Heart Association*, 1993;22:839-846.
- Uchida, Fumiya et al, Effect of Radiofrequency Catheter Ablation on Parasympathetic Denervation: A Comparison of Three Different Ablation Sites, *PACE*, vol. 21, Nov. 1998, Part II, 2517-2521.
- Valente, John F. et al, Laparoscopic Renal Denervation for Intractable ADPKD-Related Pain, *Nephrol Dial Transplant* (2001) 16:160.
- Villarreal, Daniel et al, Effects of Renal Denervation on Postprandial Sodium Excretion in Experimental Heart Failure, *American Journal of Physiology*, May 1994;266(5 Pt 2):R1599-R1604.
- Vonend, Oliver et al, Secondary Rise in Blood Pressure After Renal Denervation, *The Lancet*, vol. 380, Issue 9843, p. 778, Aug. 25, 2012.
- Vujaskovic, Z. et al, Effects of Intraoperative Hyperthermia on Canine Sciatic Nerve: Histopathologic and Morphometric Studies, *Int. J. Hyperthermia*, 1994, vol. 10, No. 6, 845-855.
- Webb, R.L. et al, Functional Identification of the Central Projections of Afferent Renal Nerves, *Clin. and Exper.-Theory and Practice*, Ag(SUPPL.I), 47-57 (1987).
- Weinstock, Marta et al, Renal Denervation Prevents Sodium Retention and Hypertension in Salt-Sensitive Rabbits with Genetic Baroreflex Impairment, *Clinical Science* (1996) 90, 287-293.
- Wilcox, Josiah N., *Scientific Basis Behind Renal Denervation for the Control of Hypertension*, Medtronic, Inc., Dec. 2012, 38 pages.
- Winternitz, Sherry R. et al, Role of the Renal Sympathetic Nerves in the Development and Maintenance of Hypertension in the Spontaneously Hypertensive Rat, *Journal of Clinical Investigation*, vol. 66 Nov. 1980, 971-978.
- Wolf-Maier, Katharina et al, Hypertension Treatment and Control in Five European Countries, Canada, and the United States, *Hypertension*. 2004;43:10-17.
- Worthley, Stephen G. et al, Renal Denervation: How Do You Measure Success?, presentation 28 pages; Jul. 30, 2013.
- Wyss, J.M. et al, Sensory Denervation of the Kidney Attenuates Renovascular Hypertension in the Rat, *Am J Physiol Heart Circ Physiol* 250:H82-H86, 1986.
- Yamada, Yutaka et al, Age-Related Changes in Muscle Sympathetic Nerve Activity in Essential Hypertension, *Hypertension Journal of The American Heart Association*, 1989;13:870-877.
- Young, Robert R. et al, Reversible Block of Nerve Conduction by Ultrasound Ultrasonic Blocking of Nerve Fibers, *Arch Neurol.* 1961;4(1):83-89.

* cited by examiner

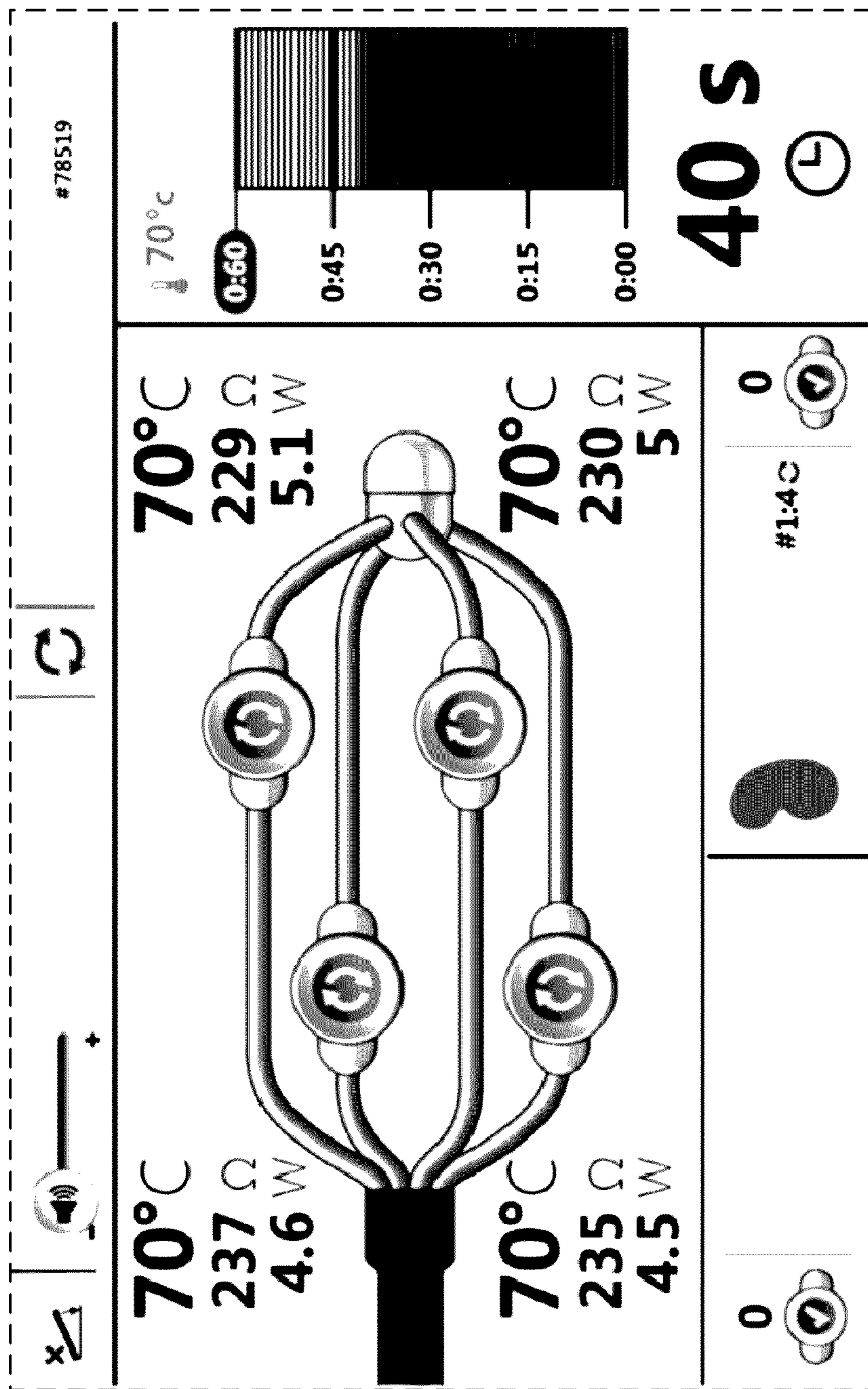

FIG. 1

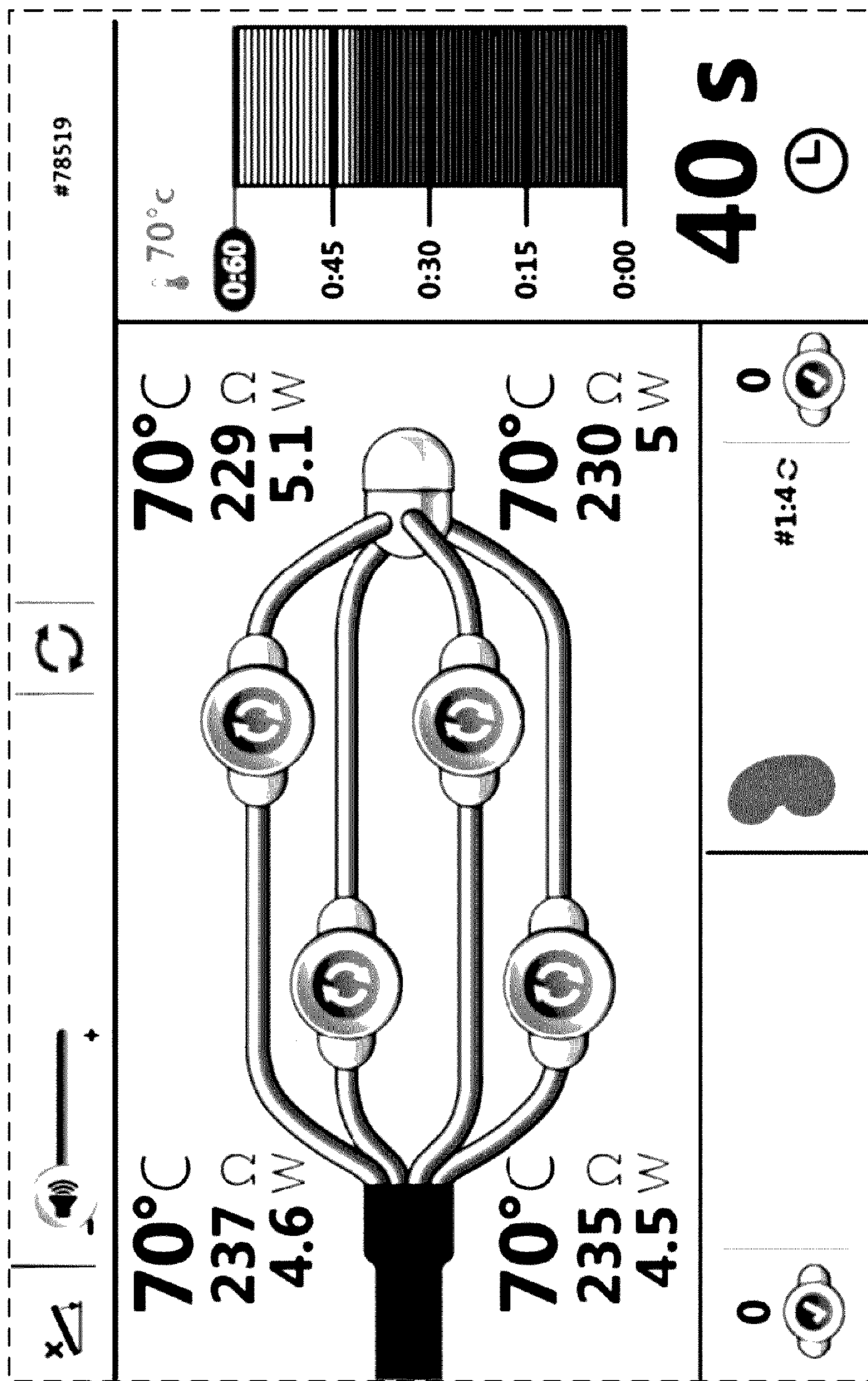

FIG. 2