



US00D773376S

(12) **United States Design Patent** (10) **Patent No.:** **US D773,376 S**
Kasparian et al. (45) **Date of Patent:** **** *Dec. 6, 2016**

(54) **COCKPIT ARMREST**
(71) Applicant: **Gulfstream Aerospace Corporation**,
Savannah, GA (US)
(72) Inventors: **Aram Kasparian**, Savannah, GA (US);
Andrew Fulford, Northville, MI (US);
Mathieu Roy, Savannah, GA (US)
(73) Assignee: **Gulfstream Aerospace Corporation**,
Savannah, GA (US)

D506,336 S * 6/2005 Bock D6/366
D508,052 S 8/2005 Kit et al.
D535,840 S * 1/2007 Smith D6/366
D562,738 S * 2/2008 Young D12/126
D594,680 S * 6/2009 Gilbert D6/716.2
D606,345 S * 12/2009 Tsai D6/366
D707,479 S * 6/2014 Egger D6/716.2
D723,559 S * 3/2015 Hein D14/413
D725,581 S * 3/2015 Ringer D12/415
D730,946 S * 6/2015 White D15/28
2010/0078525 A1 * 4/2010 Kummle B64C 13/04
244/236
2014/0175220 A1 6/2014 Durand et al.
2014/0175222 A1 6/2014 Zaneboni et al.

(*) Notice: This patent is subject to a terminal disclaimer.

(**) Term: **14 Years**

(21) Appl. No.: **29/506,168**

(22) Filed: **Oct. 14, 2014**

(51) **LOC (10) Cl.** **12-07**

(52) **U.S. Cl.**
USPC **D12/345**; D12/421

(58) **Field of Classification Search**
USPC D6/336, 384, 653, 654, 665, 657, 663,
D6/672, 573, 716.2; D7/602, 603, 614;
D12/319, 323, 325, 336, 345, 192, 423,
D12/415, 416, 179, 180, 182, 419, 421;
D21/436, 447, 448, 449, 453; D13/184
CPC B64C 13/04; B64D 11/0007; B64D
11/0015; B64D 11/003; B64D 11/04;
B64D 2011/0046; B64D 11/0629; B64B
1/10; A47C 7/54

See application file for complete search history.

(56) **References Cited**

U.S. PATENT DOCUMENTS

D277,916 S * 3/1985 Aronowitz D6/716.2
D305,048 S 12/1989 Moomaw
D317,950 S 7/1991 Tse
D442,790 S * 5/2001 Simons, Jr. D6/366
D444,149 S 6/2001 Miller et al.
D502,910 S * 3/2005 Klopp, III D12/421

OTHER PUBLICATIONS

USPTO, Notice of Allowance and Fee(s) Due in Design U.S. Appl. No. 29/506,129 mailed Jul. 1, 2015.

* cited by examiner

Primary Examiner — Robert M Spear
Assistant Examiner — Marissa J Cash
(74) *Attorney, Agent, or Firm* — Lorenz & Kopf, LLP
(LKGGlobal)

(57) **CLAIM**
The ornamental design for a cockpit armrest, as shown and described.

DESCRIPTION

FIG. 1 is a front perspective view of a cockpit armrest showing our new design;
FIG. 2 is a front view thereof;
FIG. 3 is a back view thereof;
FIG. 4 is a first side view thereof;
FIG. 5 is a second side view thereof;
FIG. 6 is a top view thereof;
FIG. 7 is a bottom view thereof; and,
FIG. 8 is a front perspective view thereof in a cockpit side ledge.
The broken lines illustrate structure and environment that form no part of the claimed design.

1 Claim, 7 Drawing Sheets

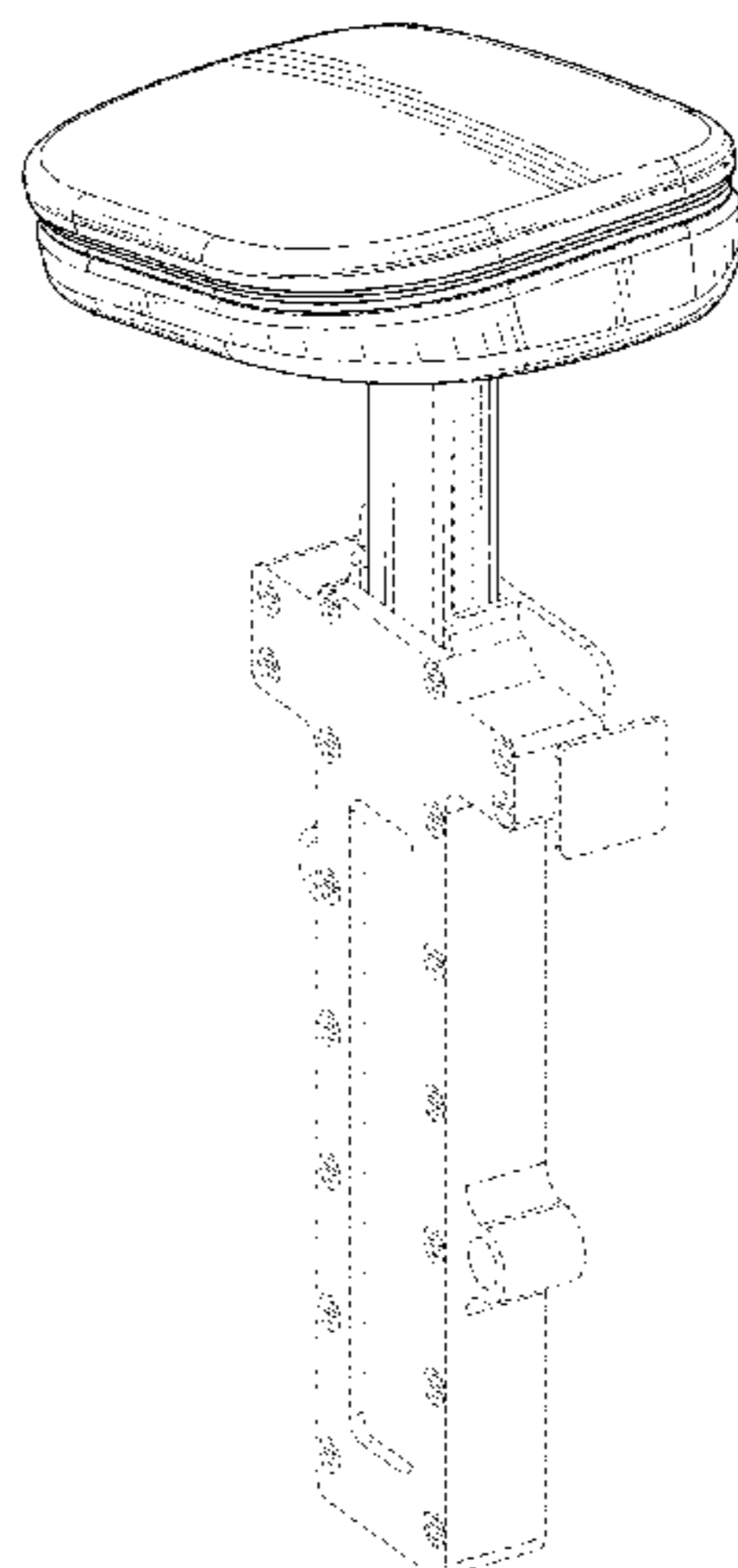

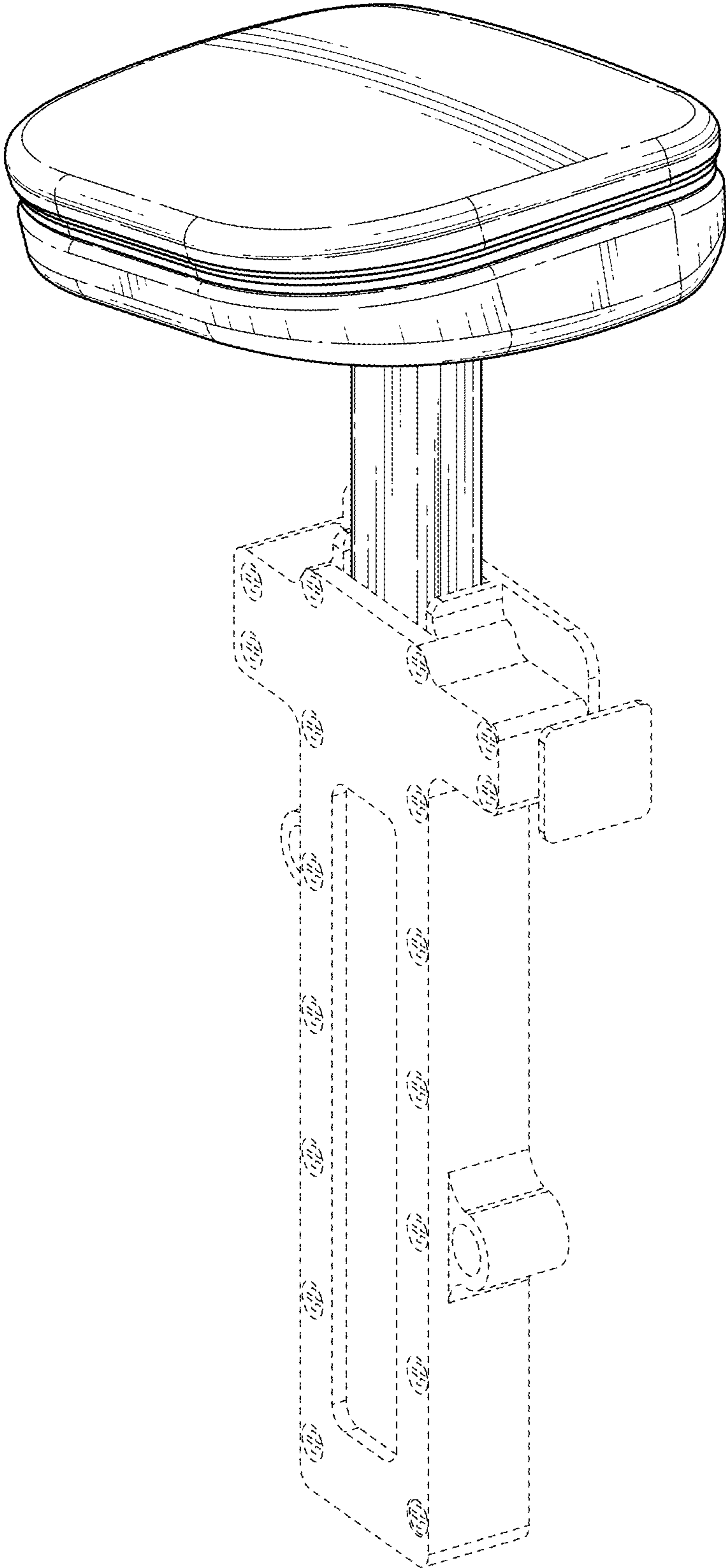

FIG. 1

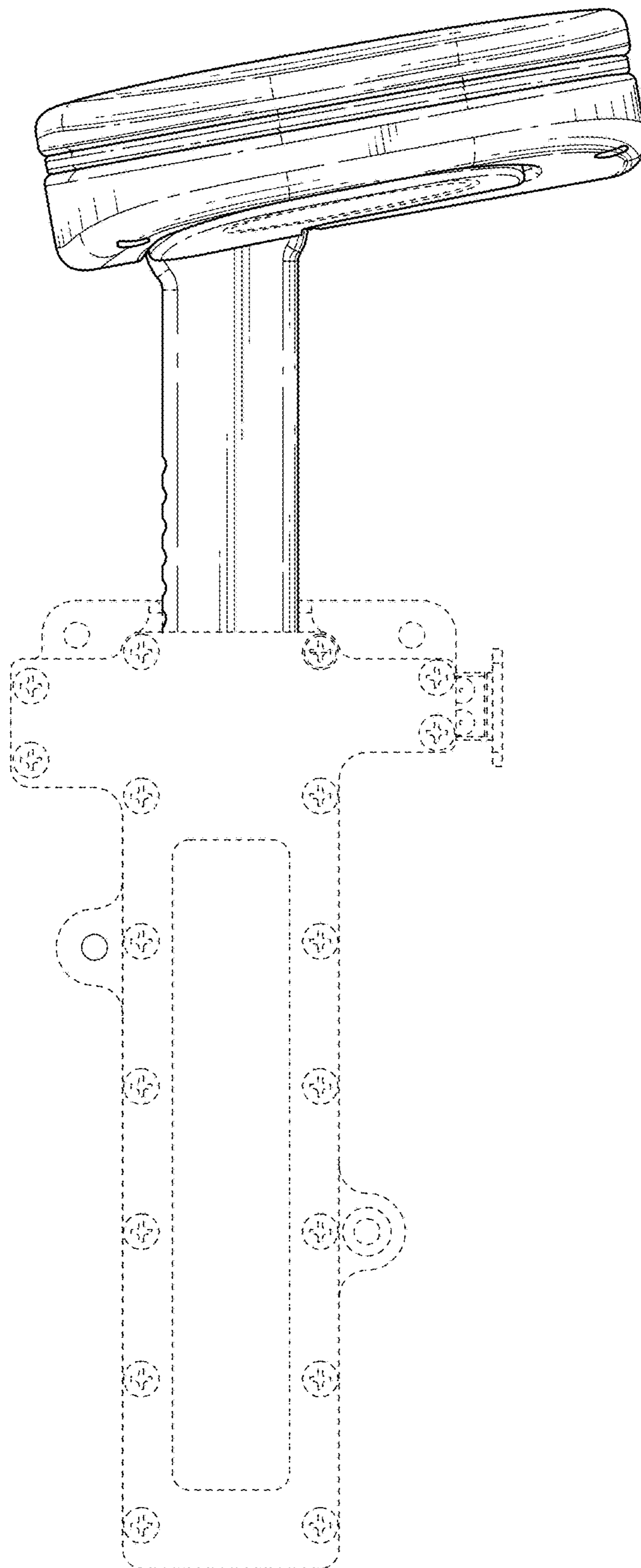

FIG. 2

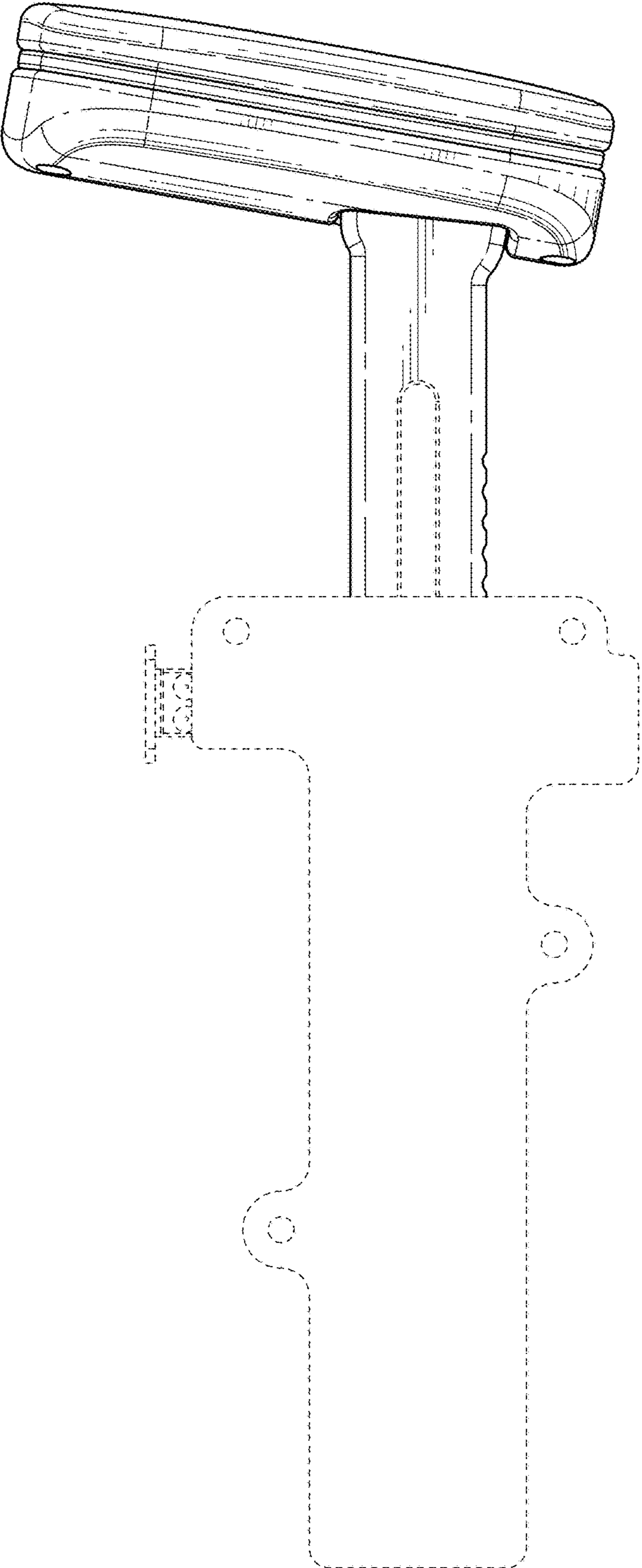

FIG. 3

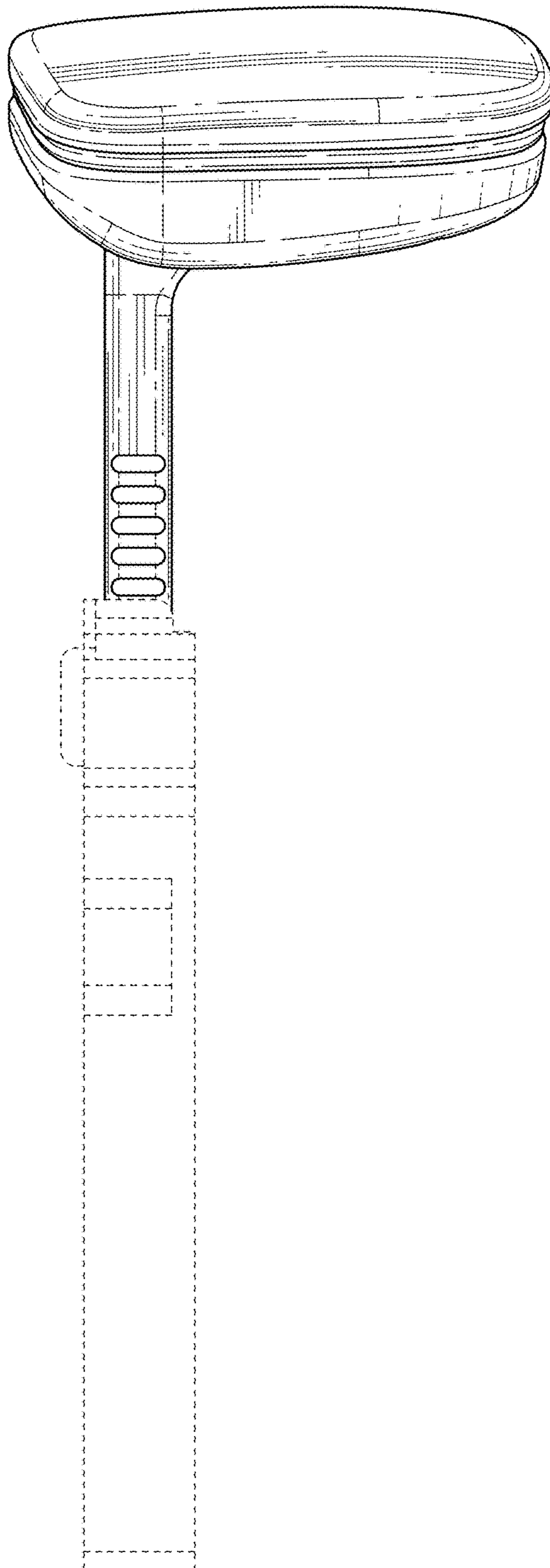

FIG. 4

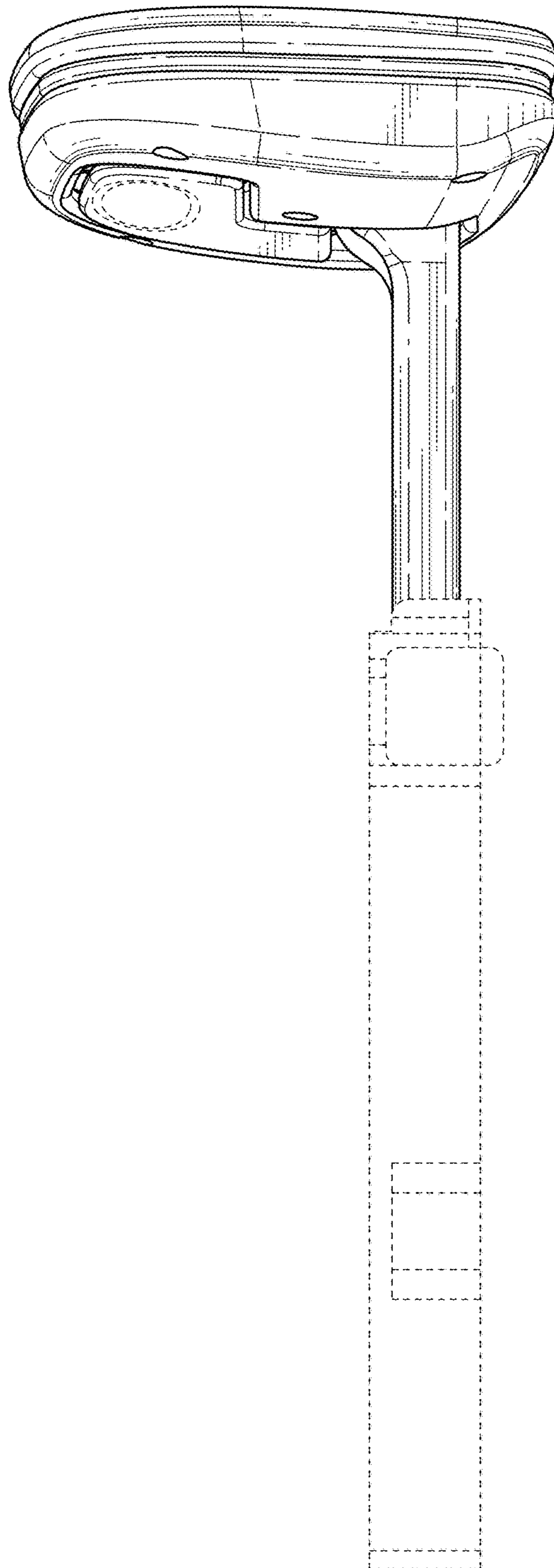

FIG. 5

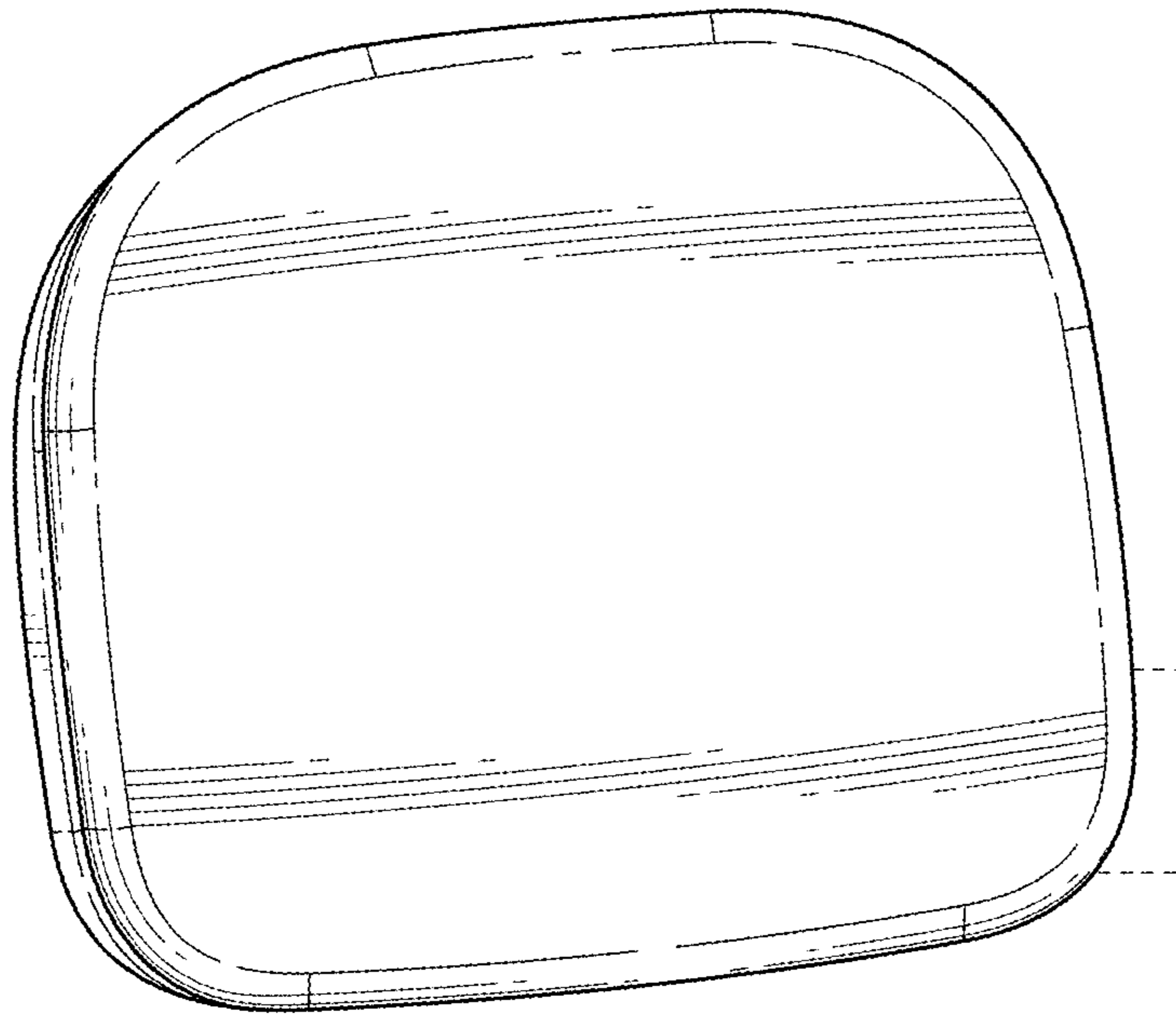

FIG. 6

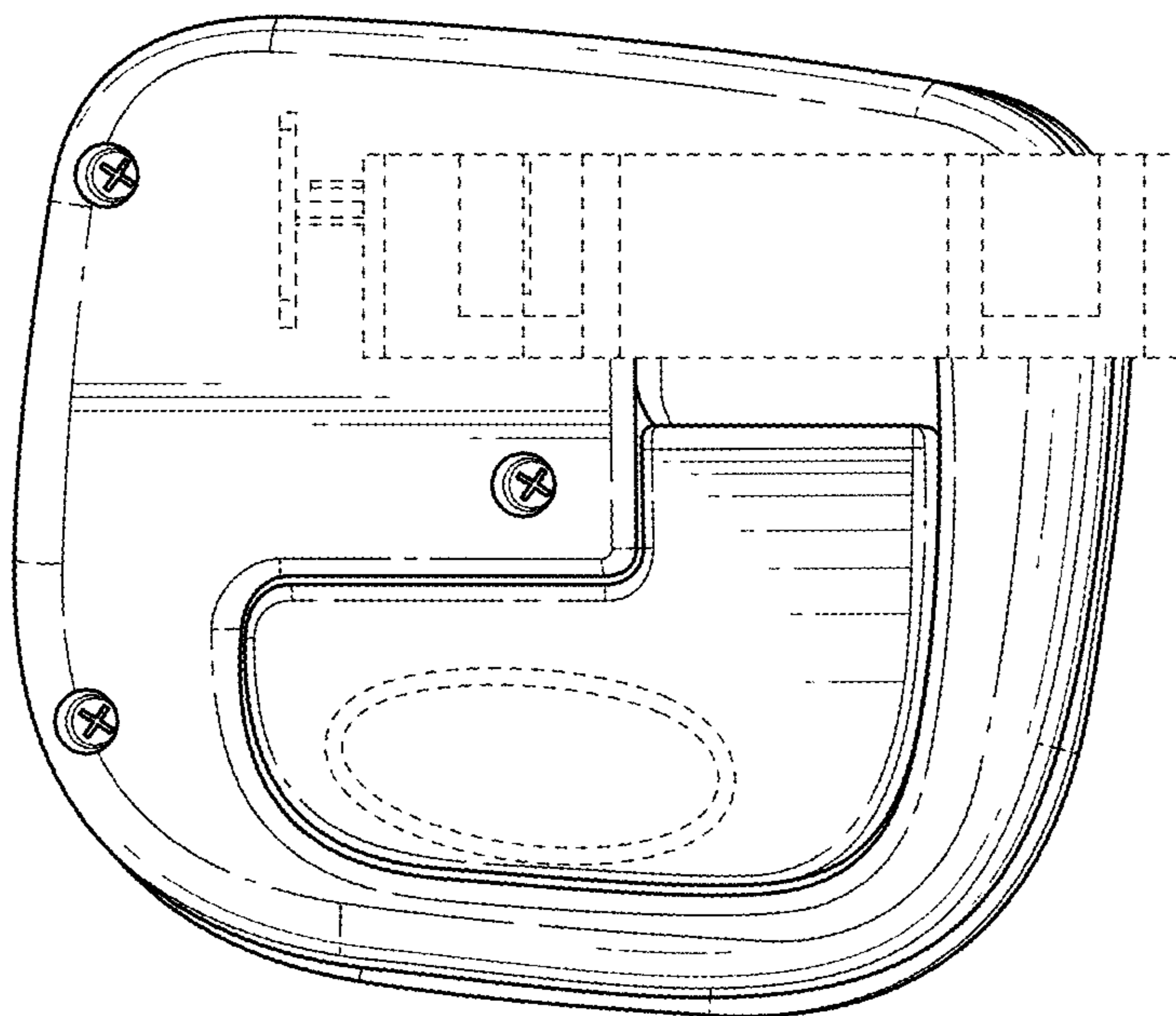

FIG. 7

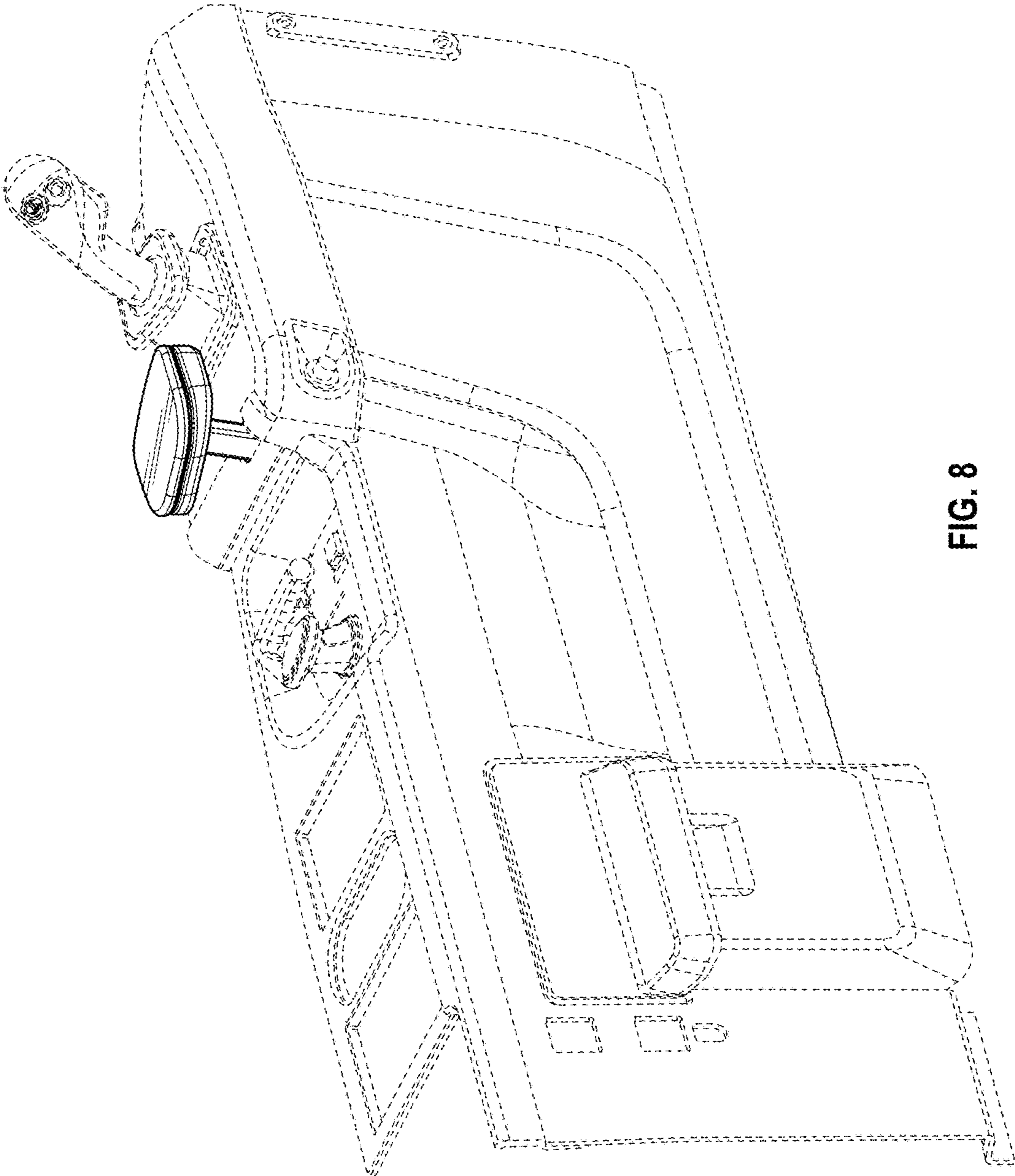

FIG. 8