



US00D773360S

(12) **United States Design Patent** (10) **Patent No.:** **US D773,360 S**  
**Heilaneh et al.** (45) **Date of Patent:** **\*\* Dec. 6, 2016**

- (54) **CENTER PANEL OF ROOF FAIRING**
- (71) Applicants: **Louis D. Heilaneh**, Lewisville, TX  
(US); **Hanson Morris**, Fort Worth, TX  
(US); **Bradley D. Powell**, Corinth, TX  
(US)
- (72) Inventors: **Louis D. Heilaneh**, Lewisville, TX  
(US); **Hanson Morris**, Fort Worth, TX  
(US); **Bradley D. Powell**, Corinth, TX  
(US)

- D312,805 S 12/1990 Marlowe et al.
- D313,966 S 1/1991 Marlowe et al.
- D314,163 S 1/1991 Harris et al.
- 4,991,906 A 2/1991 Fingerle
- D319,036 S 8/1991 Fingerle
- D319,807 S 9/1991 Simons et al.
- D320,582 S 10/1991 Fingerle
- D320,583 S 10/1991 Simons et al.
- 5,054,799 A 10/1991 Fingerle
- D329,214 S 9/1992 Marlowe et al.

(Continued)

- (73) Assignee: **PACCAR Inc**, Bellevue, WA (US)
- (\*\*) Term: **15 Years**

OTHER PUBLICATIONS

“Class Pays,” Peterbilt Motors Company, Denton, Texas, Sep. 1997, 10-page brochure.

(Continued)

- (21) Appl. No.: **29/530,908**
- (22) Filed: **Jun. 22, 2015**
- (51) **LOC (10) Cl.** ..... **12-08**
- (52) **U.S. Cl.**  
USPC ..... **D12/181**
- (58) **Field of Classification Search**  
USPC ..... D12/181, 191, 196, 400, 190, 88  
CPC ..... B60R 13/04; B60R 13/02  
See application file for complete search history.

Primary Examiner — Katrina A Betton

(74) Attorney, Agent, or Firm — Christensen O’Connor Johnson Kindness PLLC

(57) **CLAIM**

The ornamental design for a center panel of roof fairing, as shown.

(56) **References Cited**

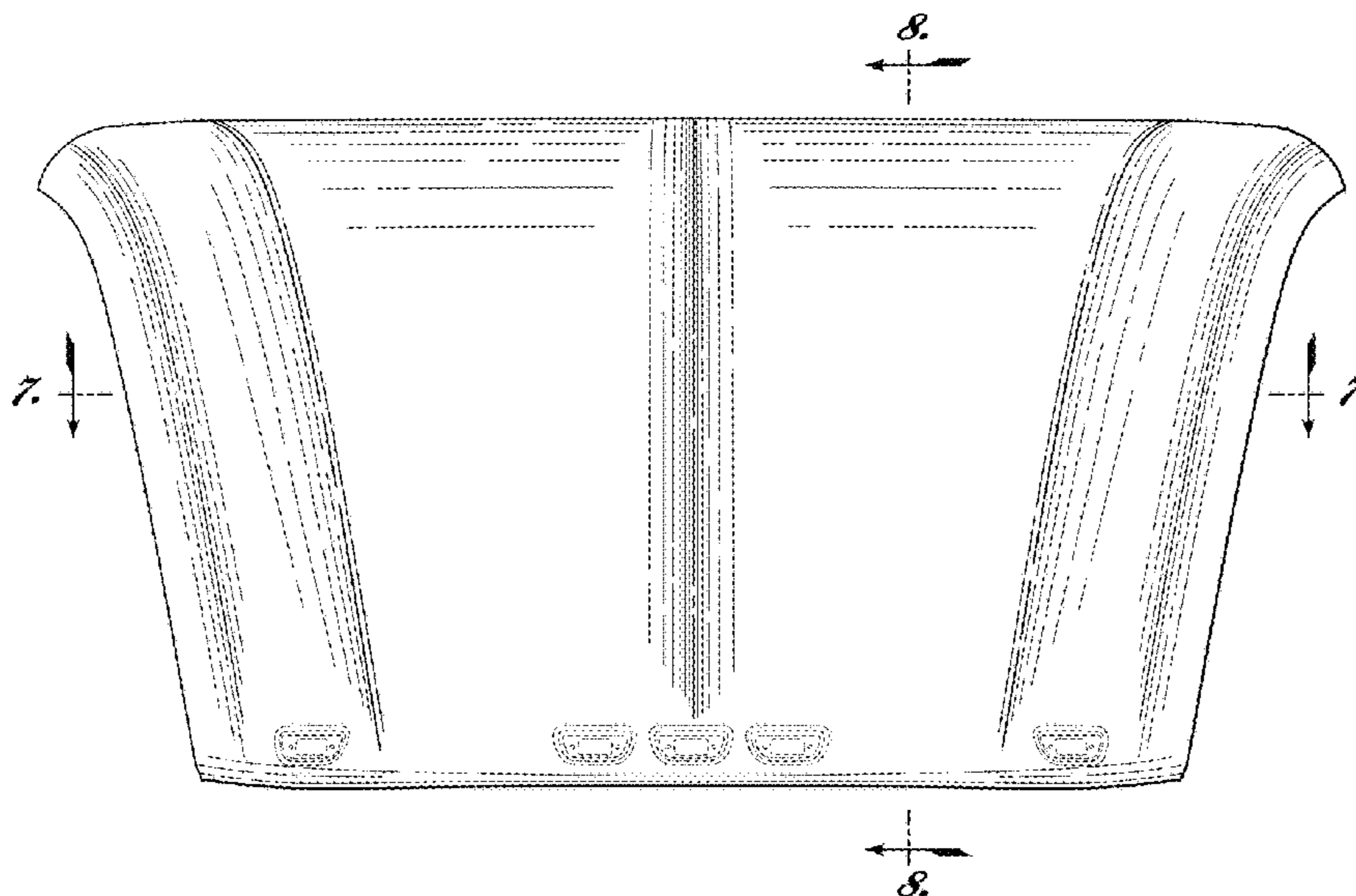
U.S. PATENT DOCUMENTS

**DESCRIPTION**

- D265,983 S 8/1982 Sullivan et al.
- D268,021 S 2/1983 Wiley, Jr. et al.
- 4,401,338 A 8/1983 Caldwell
- 4,408,792 A 10/1983 Sullivan
- D271,191 S 11/1983 Amprim et al.
- D289,891 S 5/1987 Bielby
- D290,455 S 6/1987 Konen et al.
- D307,731 S 5/1990 Kerney et al.
- D308,032 S 5/1990 Kerney et al.
- 4,925,235 A 5/1990 Fingerle
- D311,506 S 10/1990 Marlowe et al.

FIG. 1 depicts a perspective view of the center panel of roof fairing according to our new design; FIG. 2 depicts a front view thereof; FIG. 3 depicts a top view thereof; FIG. 4 depicts a left side view thereof; FIG. 5 depicts a right side view thereof; FIG. 6 depicts a rear view thereof; FIG. 7 depicts a horizontal cross-sectional view thereof; and, FIG. 8 depicts a vertical cross-sectional view thereof. The broken lines show portions of the fender skirt which form no part of the claimed design.

**1 Claim, 8 Drawing Sheets**



(56)

References Cited

U.S. PATENT DOCUMENTS

D335,855	S	5/1993	Callaway et al.	
5,249,937	A	10/1993	Aubert	
D341,563	S	11/1993	Niemi	
D343,819	S	2/1994	Meryman et al.	
D356,770	S	3/1995	Almen	
D374,418	S	10/1996	Griffin	
D375,925	S	11/1996	Griffin	
D381,949	S	8/1997	Barrett, Jr. et al.	
D384,914	S	10/1997	Bingaman	
D385,223	S	10/1997	Marlowe et al.	
D391,524	S	3/1998	Anderson et al.	
D395,269	S	6/1998	McCauley, Jr.	
D395,848	S	7/1998	Meryman et al.	
D399,465	S	10/1998	Saleen	
D399,791	S	10/1998	Hellhake et al.	
D399,792	S	10/1998	Hellhake et al.	
D400,158	S	10/1998	Meryman et al.	
D403,999	S	1/1999	Lund	
D411,140	S	6/1999	Meryman et al.	
D422,957	S	4/2000	Damon et al.	
D423,990	S	5/2000	Meryman et al.	
D424,011	S	5/2000	Morris	
D424,489	S	5/2000	Damon et al.	
D424,999	S	5/2000	Carlson et al.	
D431,511	S	10/2000	Damon et al.	
D433,365	S	11/2000	Beigel	
D433,967	S	11/2000	Delashaw et al.	
D433,981	S	11/2000	Davis et al.	
D434,347	S	11/2000	Damon et al.	
D434,348	S	11/2000	Delashaw et al.	
D435,237	S	12/2000	Damon et al.	
D436,894	S	1/2001	Barracough et al.	
D437,258	S	2/2001	Meryman et al.	
D460,023	S	7/2002	Beigel	
D465,749	S	11/2002	Beigel	
D475,657	S	6/2003	Wong et al.	
D476,929	S	7/2003	Dozier et al.	
D496,620	S	9/2004	Perfetti et al.	
D499,679	S	12/2004	Perfetti et al.	
6,986,544	B2	1/2006	Wood	
D519,891	S	5/2006	Lai	
D522,426	S	6/2006	Beigel et al.	
D522,945	S	6/2006	Beigel et al.	
D531,946	S	11/2006	Angelo et al.	
D531,948	S	11/2006	Angelo et al.	
D532,731	S	11/2006	Angelo et al.	
D535,597	S *	1/2007	Herpel .....	D12/181
D558,643	S	1/2008	Beigel et al.	
D567,156	S	4/2008	Hutchins	
D589,420	S *	3/2009	Raghavendran .....	D12/181
D595,628	S *	7/2009	Boyd .....	D12/181
D597,908	S	8/2009	Raghavendran et al.	
D603,315	S	11/2009	Gamou	
D607,359	S	1/2010	Mammoto et al.	
D613,224	S	4/2010	Beigel et al.	
D633,015	S *	2/2011	Peltola .....	D12/181
D643,353	S *	8/2011	Balicki .....	D12/181
D666,541	S	9/2012	Stimel, Jr.	
D686,123	S *	7/2013	Peltola .....	D12/181
D687,359	S *	8/2013	Peltola .....	D12/181
D699,648	S	2/2014	Sancer et al.	
D707,608	S	6/2014	Smith	
D709,007	S	7/2014	Henry et al.	
D709,008	S	7/2014	Brzustowicz et al.	
D709,009	S	7/2014	Brzustowicz et al.	
D710,773	S *	8/2014	Ito .....	D12/181

OTHER PUBLICATIONS

“Class Pays,” Peterbilt Motors Company, Denton, Texas, Nov. 1998, 10-page brochure.  
 “Class Pays, Truck Models,” Peterbilt Motors Company, Denton, Texas, Mar. 2005, 24-page brochure.

“Kenworth Truck Models,” Kenworth Truck Company, Kirkland, Washington, 2010, 16-page brochure.  
 “Model 377A/E,” Peterbilt Motors Company, Denton, Texas, Jan. 1995, 6-page brochure.  
 “Model 377A/E,” Peterbilt Motors Company, Denton, Texas, Aug. 1997, 2-page brochure.  
 “Model 385,” Peterbilt Motors Company, Denton, Texas, Oct. 1996, 5-page brochure.  
 “Model 387,” Peterbilt Motors Company, Denton, Texas, Oct. 2002, 2-page brochure.  
 “T600,” Kenworth Truck Company, Kirkland, Washington, 2002, 28-page brochure.  
 “T600,” Kenworth Truck Company, Kirkland, Washington, 2005, 24-page brochure.  
 “T660,” Kenworth Truck Company, Kirkland, Washington, 2007, 36-page brochure.  
 “T660,” Kenworth Truck Company, Kirkland, Washington, 2009, 36-page brochure.  
 “T700,” Kenworth Truck Company, Kirkland, Washington, 2010, 6-page brochure.  
 “T2000,” Kenworth Truck Company, Kirkland, Washington, 1999, 20-page brochure.  
 “T2000,” Kenworth Truck Company, Kirkland, Washington, 2002, 20-page brochure.  
 “T2000,” Kenworth Truck Company, Kirkland, Washington, 2005, 20-page brochure.  
 “AeroCab,” Kenworth Truck Company, Kirkland, Washington, as early as 1995, 3-page brochure.  
 “T600,” Kenworth Truck Company, Kirkland, Washington, 1996, 7-page brochure.  
 “Unibilt™ Cab Sleeper System,” Peterbilt Motors Company, Denton Texas, Aug. 1994, 6-page brochure.  
 “W900,” Kenworth Truck Company, Kirkland, Washington, 1996, 7-page brochure.  
 “Model 378,” Peterbilt Motors Company, Denton, Texas, Mar. 1998, 3-page brochure.  
 “T800,” Kenworth Truck Company, Kirkland, Washington, 2002, 32-page brochure.  
 “W900,” Kenworth Truck Company, Kirkland, Washington, 2002, 32-page brochure.  
 “T800,” Kenworth Truck Company, Kirkland, Washington, 2003, 32-page brochure.  
 “W900,” Kenworth Truck Company, Kirkland, Washington, 2005, 28-page brochure.  
 “T800,” Kenworth Truck Company, Kirkland, Washington, 2009, 28-page brochure.  
 “W900,” Kenworth Truck Company, Kirkland, Washington, 2009, 28-page brochure.  
 “AG130 Front Air Suspension,” Kenworth Truck Company, Kirkland, Washington, 2008, 2-page brochure.  
 “C500B,” Kenworth Truck Company, Kirkland, Washington, as early as 1990, 4-page brochure.  
 “Class Pays, Construction Trucks,” Peterbilt Motors Company, Denton, Texas, Nov. 2003, 16-page brochure.  
 “Interiors,” Kenworth Truck Company, Kirkland, Washington, 2005, 16-page brochure.  
 “K100E,” Kenworth Truck Company, Kirkland, Washington, 1984, 8-page brochure.  
 “PACCAR Engines, 2010 Medium Duty Engines,” PACCAR Inc, Bellevue, Washington, 2010, 6-page brochure.  
 “PACCAR MX,” Paccar Inc, Bellevue, Washington, 2010, 4-page brochure.  
 “Studio Sleeper,” Kenworth Truck Company, Kirkland, Washington, 1993, 5-page brochure.  
 “T170 Class 5,” Kenworth Truck Company, Kirkland, Washington, 2008, 4-page brochure.  
 “T270 Class 6 and T370 Class 7,” Kenworth Truck Company, Kirkland, Washington, 2008, 6-page brochure.  
 “T270 Class 6 and T370 Class 7,” Kenworth Truck Company, Kirkland, Washington, 2009, 6-page brochure.  
 “T270 Class 6 and T370 Class 7 Hybrid,” Kenworth Truck Company, Kirkland, Washington, 2009, 6-page brochure.  
 “T300,” Kenworth Truck Company, Kirkland, Washington, 1994, 4-page brochure.

(56)

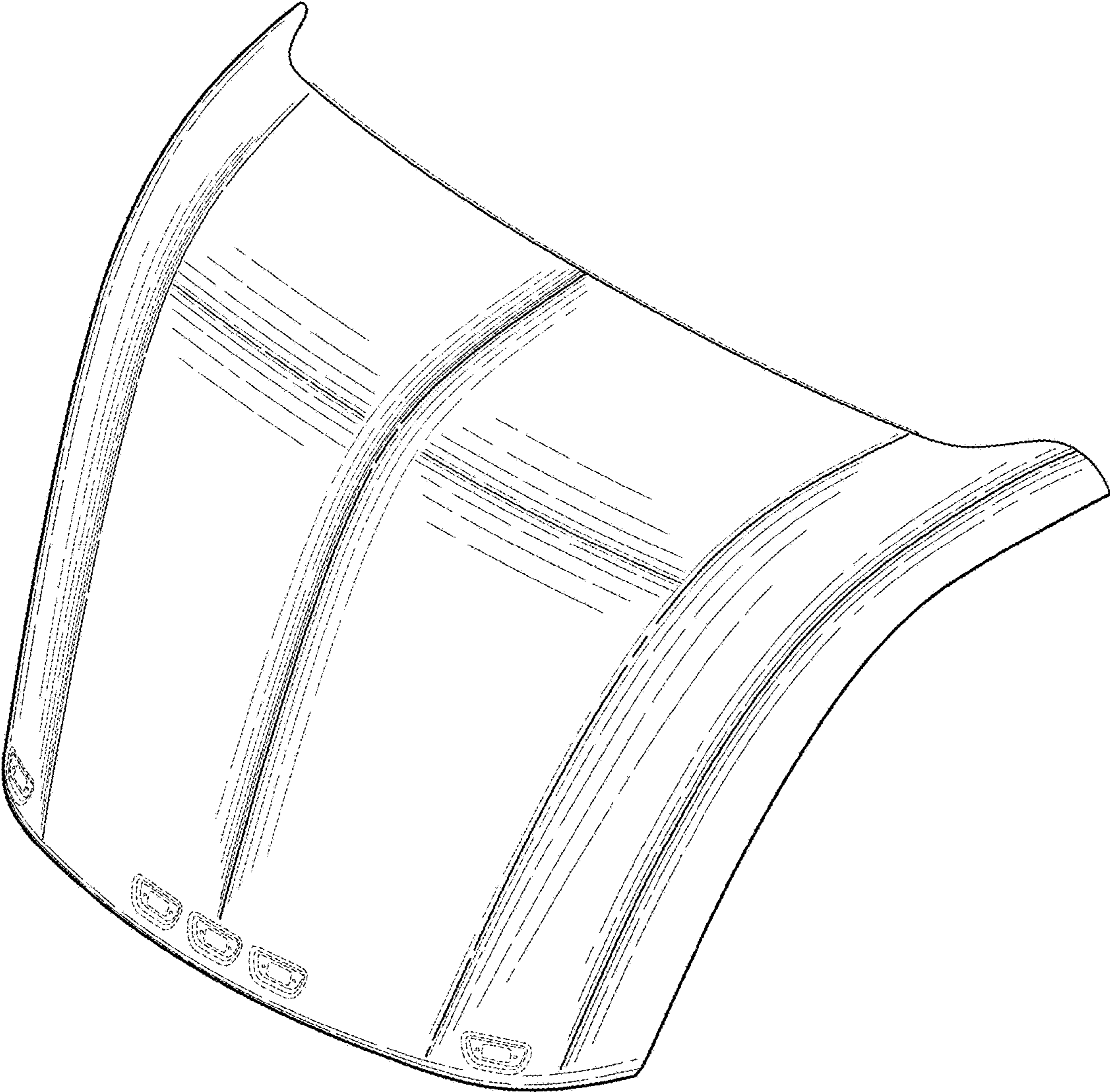
**References Cited**

OTHER PUBLICATIONS

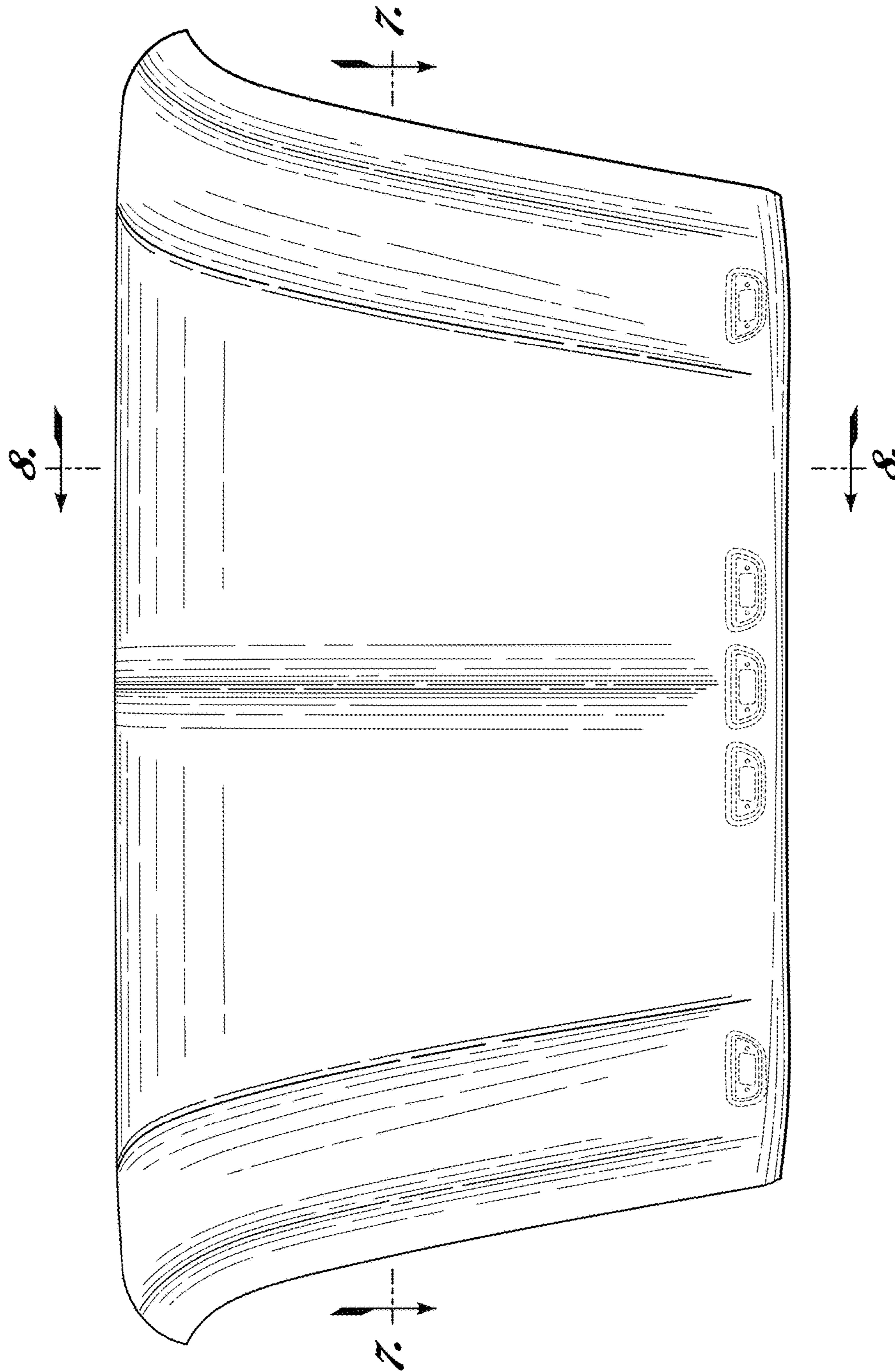
“T300,” Kenworth Truck Company, Kirkland, Washington, 2001, 16-page brochure.  
“T300,” Kenworth Truck Company, Kirkland, Washington, 2005, 16-page brochure.  
“T400B and T450B,” Kenworth Truck Company, Kirkland, Washington, 1992, 10-page brochure.  
“T440,” Kenworth Truck Company, Kirkland, Washington, 2010, 2-page brochure.  
“T440,” Kenworth Truck Company, Kirkland, Washington, 2010, 6-page brochure.  
“T470,” Kenworth Truck Company, Kirkland, Washington, 2010, 6-page brochure.  
“T470H,” Kenworth Truck Company, Kirkland, Washington, 2009, 2-page brochure.  
“T600, Ten Years of Innovation,” Kenworth Truck Company, Kirkland, Washington, 1995, 6-page brochure.  
“T800,” Kenworth Truck Company, Kirkland, Washington, 2005, 28-page brochure.  
“T800B,” Kenworth Truck Company, Kirkland, Washington, 1993, 8-page brochure.  
“The World’s Best,” Kenworth Truck Company, Kirkland, Washington, 1992, 12-page brochure.  
“Kenworth T2000 Daycab,” Kenworth Truck Company, Kirkland, Washington, 1997, 2 pages.

“Kenworth T2000 Daycab Roof,” Kenworth Truck Company, Kirkland, Washington, 1997, 2 pages.  
“Kenworth T2000 Standard Cab with sleeper and one-piece fairing,” Kenworth Truck Company, Kirkland, Washington, 1997, 2 pages.  
Kenworth T800 Daycab with 3-piece roof fairing, at least as early as 2005, 1 page.  
Volvo Daycab, roof fairings comprised of multi-piece assembly, at least as early as 2005, 1 page.  
Foreground: International Daycab, multi-piece fairing assembly, at least as early as 2005; Background: Volvo Daycab, single-piece fairing, at least as early as 2005, 1 page.  
Left: Volvo Daycab, adjustable roof fairing, at least as early as 2005; Right: Freightliner Daycab, one-piece fairing, at least as early as 2005, 1 page.  
Mack Daycab, single-piece fairing, at least as early as 2005, 1 page.  
Ford Daycab, two-piece fairing assembly, at least as early as 2005, 1 page.  
Top: Mack Daycab, single-piece fairing, at least as early as 2005; Bottom: Volvo Daycab, multi-piece fairing assembly, at least as early as 2005, 1 page.  
International Daycab, one-piece fairing, at least as early as 2005, 1 page.  
Freightliner Daycab, multi-piece fairing assembly, at least as early as 2005, 1 page.

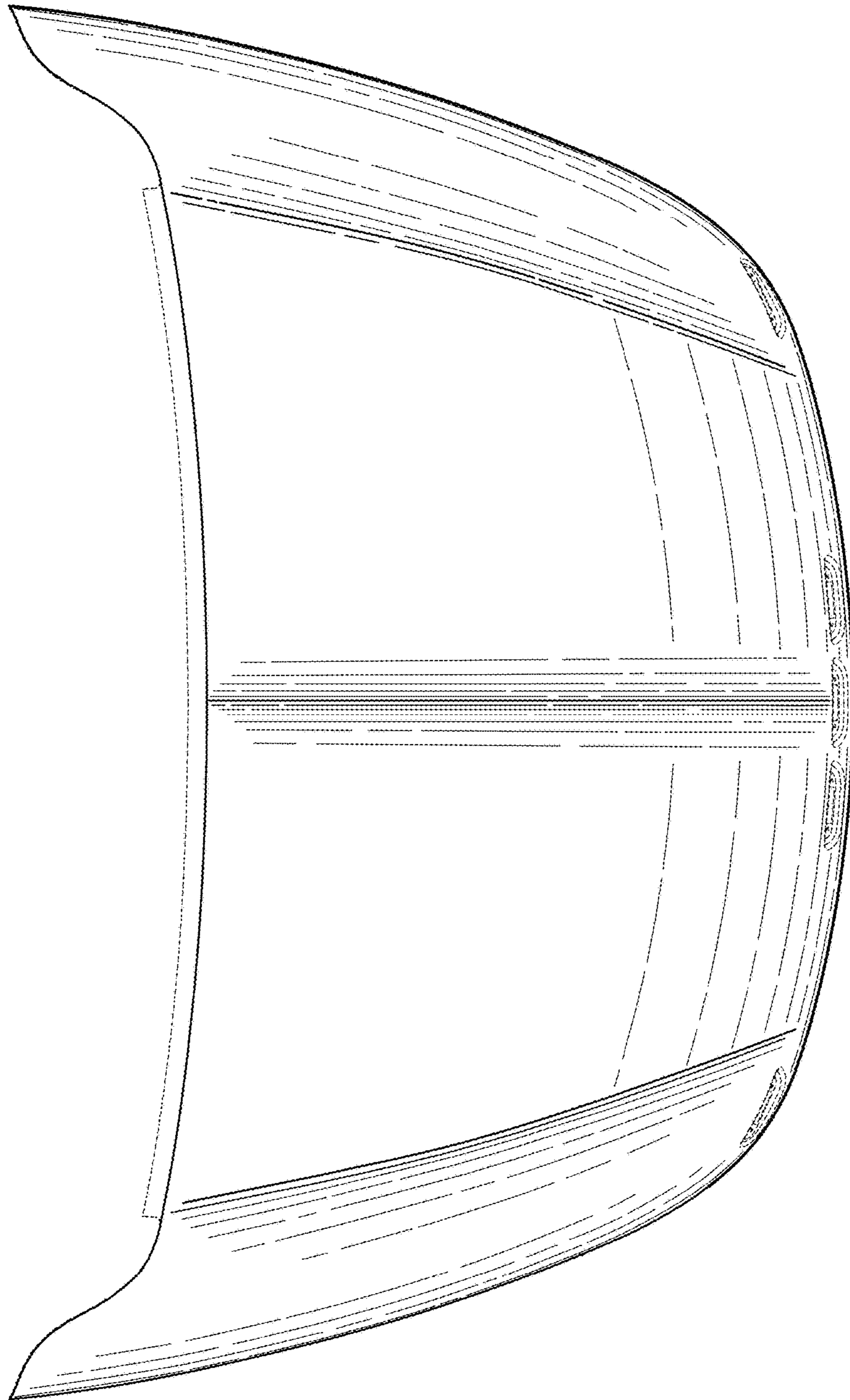
\* cited by examiner



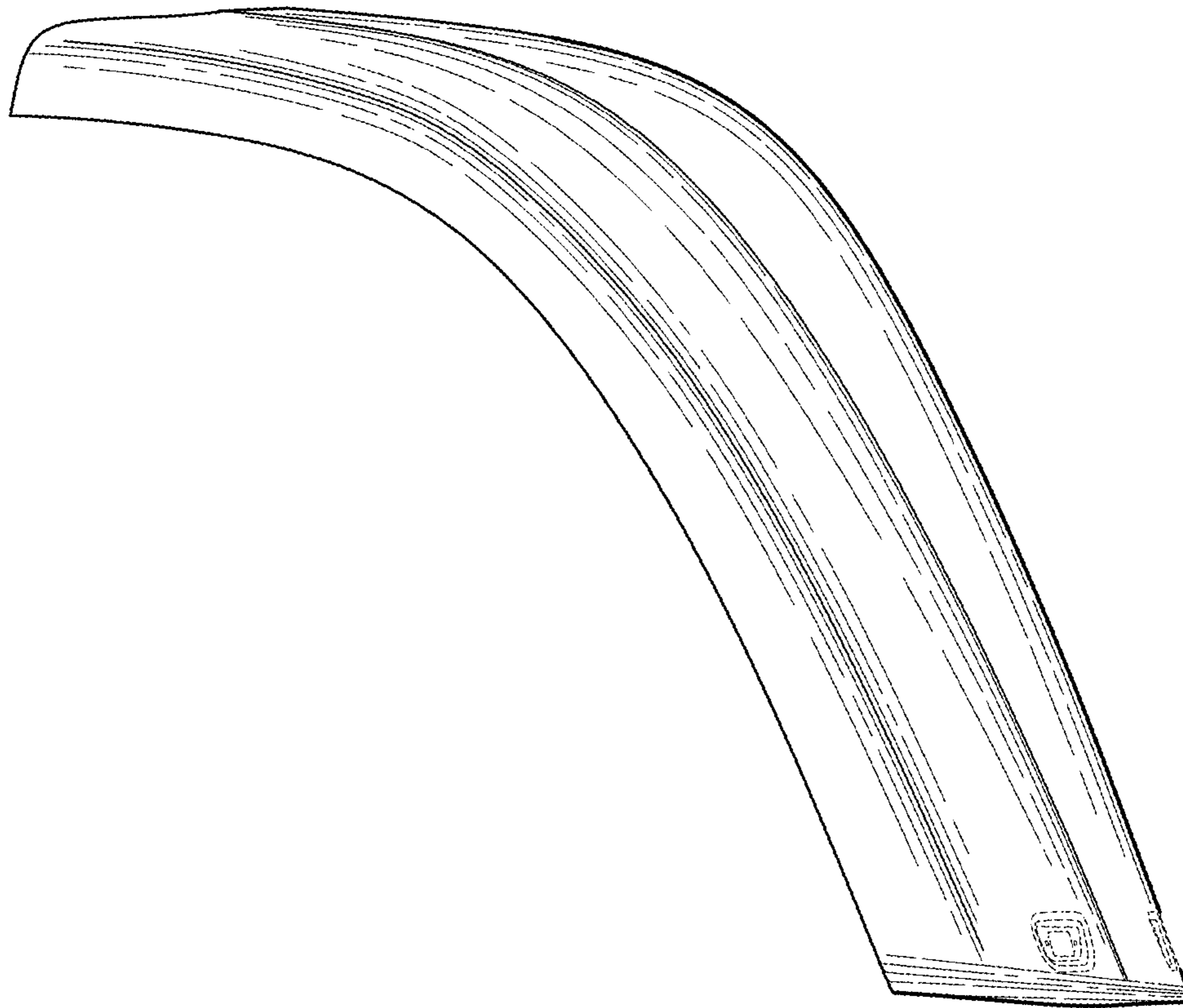
*Fig. 1.*



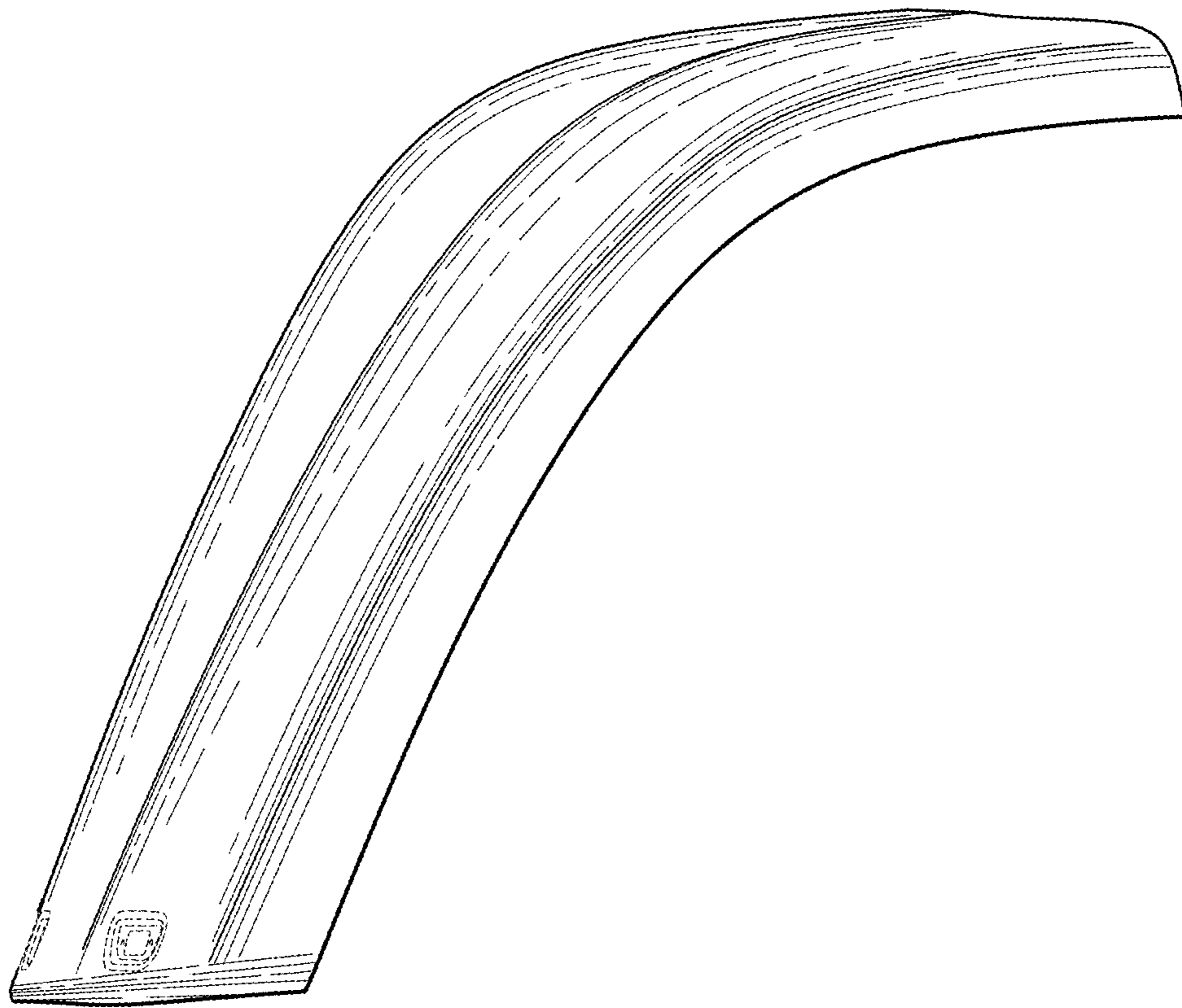
*Fig. 2.*



*Fig. 3.*

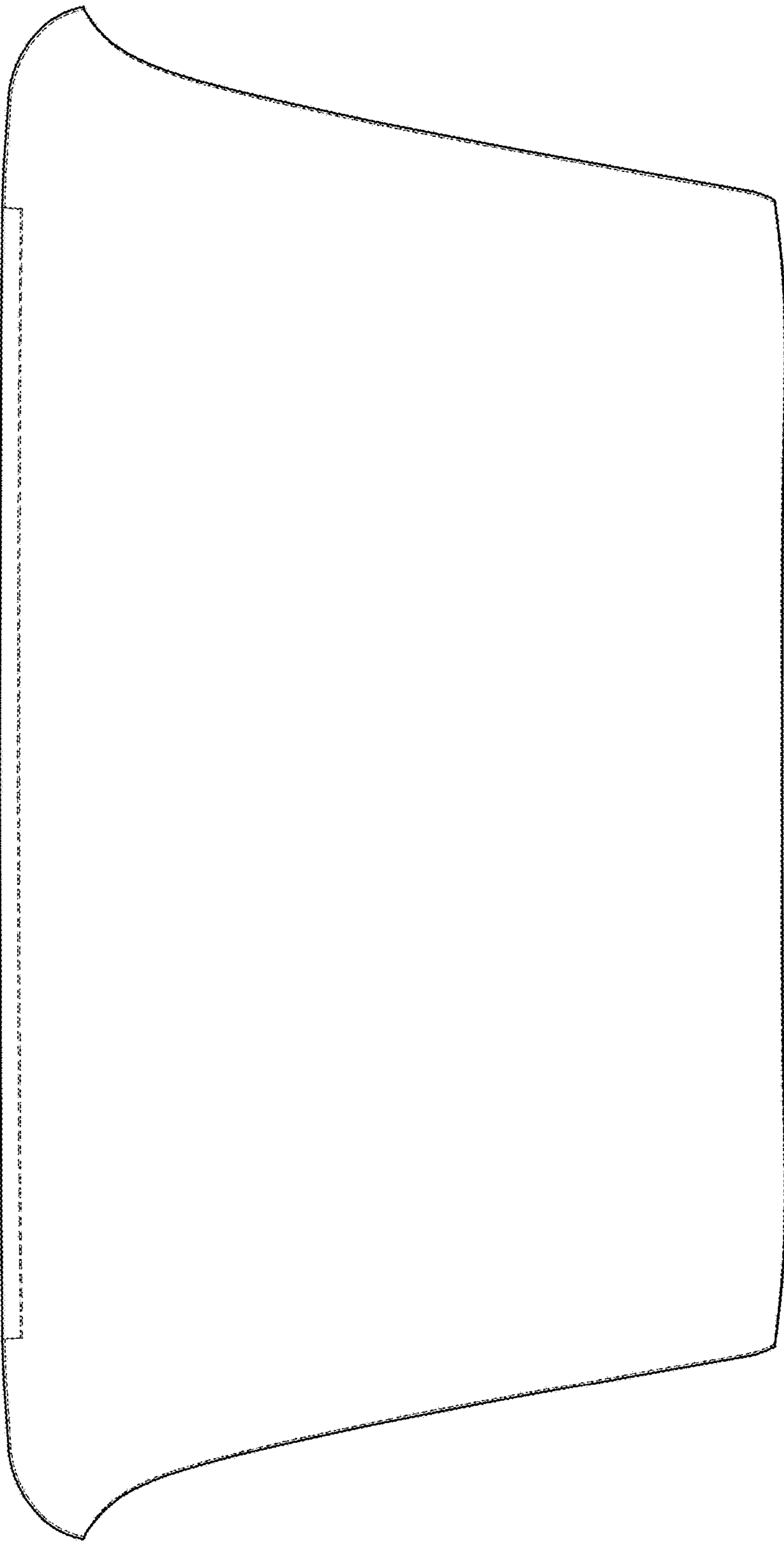


*Fig. 4.*

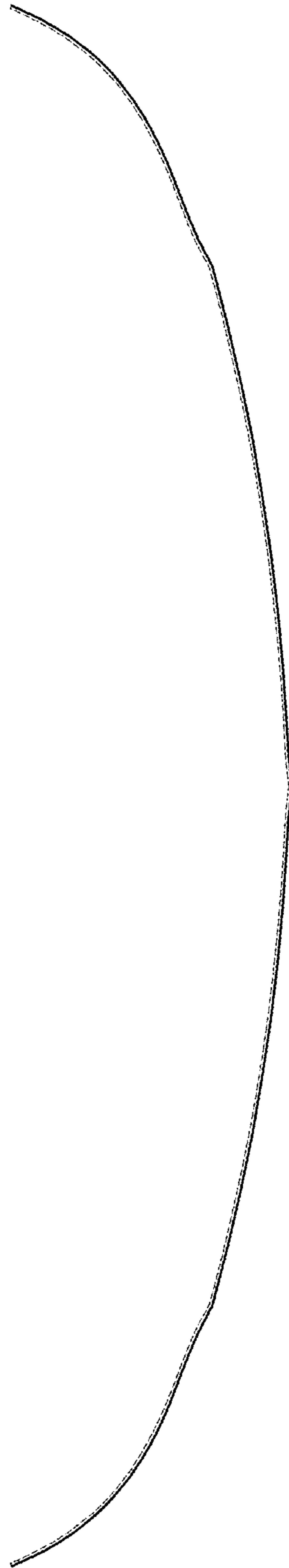


*Fig. 5.*





*Fig. 6.*



*Fig. 7.*

