



US00D772964S

(12) **United States Design Patent** (10) **Patent No.:** **US D772,964 S**
Ban (45) **Date of Patent:** **** Nov. 29, 2016**

(54) **ROLLER BEARING**
(71) Applicant: **THK CO., LTD.**, Tokyo (JP)
(72) Inventor: **Toshikazu Ban**, Tokyo (JP)
(73) Assignee: **THK CO., LTD.**, Tokyo (JP)
(**) Term: **14 Years**
(21) Appl. No.: **29/496,701**
(22) Filed: **Jul. 16, 2014**
(30) **Foreign Application Priority Data**

Jan. 17, 2014 (JP) 2014-000868
Jan. 17, 2014 (JP) 2014-000869
Jan. 17, 2014 (JP) 2014-000870
Jan. 17, 2014 (JP) 2014-000871

(51) **LOC (10) Cl.** **15-09**
(52) **U.S. Cl.**
USPC **D15/143**
(58) **Field of Classification Search**
USPC D15/143, 199
See application file for complete search history.

(56) **References Cited**

U.S. PATENT DOCUMENTS

3,256,585 A * 6/1966 Ripple F16C 19/364
269/305
4,772,139 A * 9/1988 Bretton F16C 27/04
384/535

(Continued)

FOREIGN PATENT DOCUMENTS

CN 302222133 S 12/2012
CN 302333628 S 2/2013
CN 302341601 S 3/2013

OTHER PUBLICATIONS

Taiwanese Office Action dated Feb. 24, 2015, issued in corresponding TW Patent Application No. 103304200 with English translation (5 pages).

(Continued)

Primary Examiner — Patricia Palasik
(74) *Attorney, Agent, or Firm* — Westerman, Hattori,
Daniels & Adrian, LLP

(57) **CLAIM**
The ornamental design for a roller bearing, as shown and described.

DESCRIPTION

FIG. 1 is a perspective view of a first embodiment of a roller bearing according to my design.
FIG. 2 is a front elevation view thereof. A rear elevation view, a left side elevation view and a right side elevation view are identical to the front elevation view.
FIG. 3 is a top plan view thereof.
FIG. 4 is a bottom plan view thereof.
FIG. 5 is a cross-sectional view taken along the line 5-5 in FIG. 2.
FIG. 6 is an enlarged cross-sectional view taken along the line 6-6 in FIG. 3.
FIG. 7 is an enlarged view of the portion 7 in FIG. 6.
FIG. 8 is a referential view showing the rollers.
FIG. 9 is a perspective view of a second embodiment of a roller bearing.
FIG. 10 is a front elevation view thereof. A rear elevation view, a left side elevation view and a right side elevation view are identical to the front elevation view.
FIG. 11 is a top plan view thereof.
FIG. 12 is a bottom plan view thereof.
FIG. 13 is a cross-sectional view taken along the line 13-13 in FIG. 10.
FIG. 14 is an enlarged cross-sectional view taken along the line 14-14 in FIG. 11.
FIG. 15 is an enlarged view of the portion 15 in FIG. 14.
FIG. 16 is a referential view showing the rollers.
FIG. 17 is a perspective view of a third embodiment of a roller bearing.
FIG. 18 is a front elevation view thereof. A rear elevation view, a left side elevation view and a right side elevation view are identical to the front elevation view.
FIG. 19 is a top plan view thereof.
FIG. 20 is a bottom plan view thereof.
FIG. 21 is a cross-sectional view taken along the line 21-21 in FIG. 18.
FIG. 22 is an enlarged cross-sectional view taken along the line 22-22 in FIG. 19.
FIG. 23 is an enlarged view of the portion 23 in FIG. 22; and, FIG. 24 is a referential view showing the rollers.
The portions of the roller bearing shown in broken lines are for the purpose of showing environmental structure only and form no part of the claimed design. The dash-dot-dash lines are boundary lines and form no part of the claimed design.

1 Claim, 24 Drawing Sheets

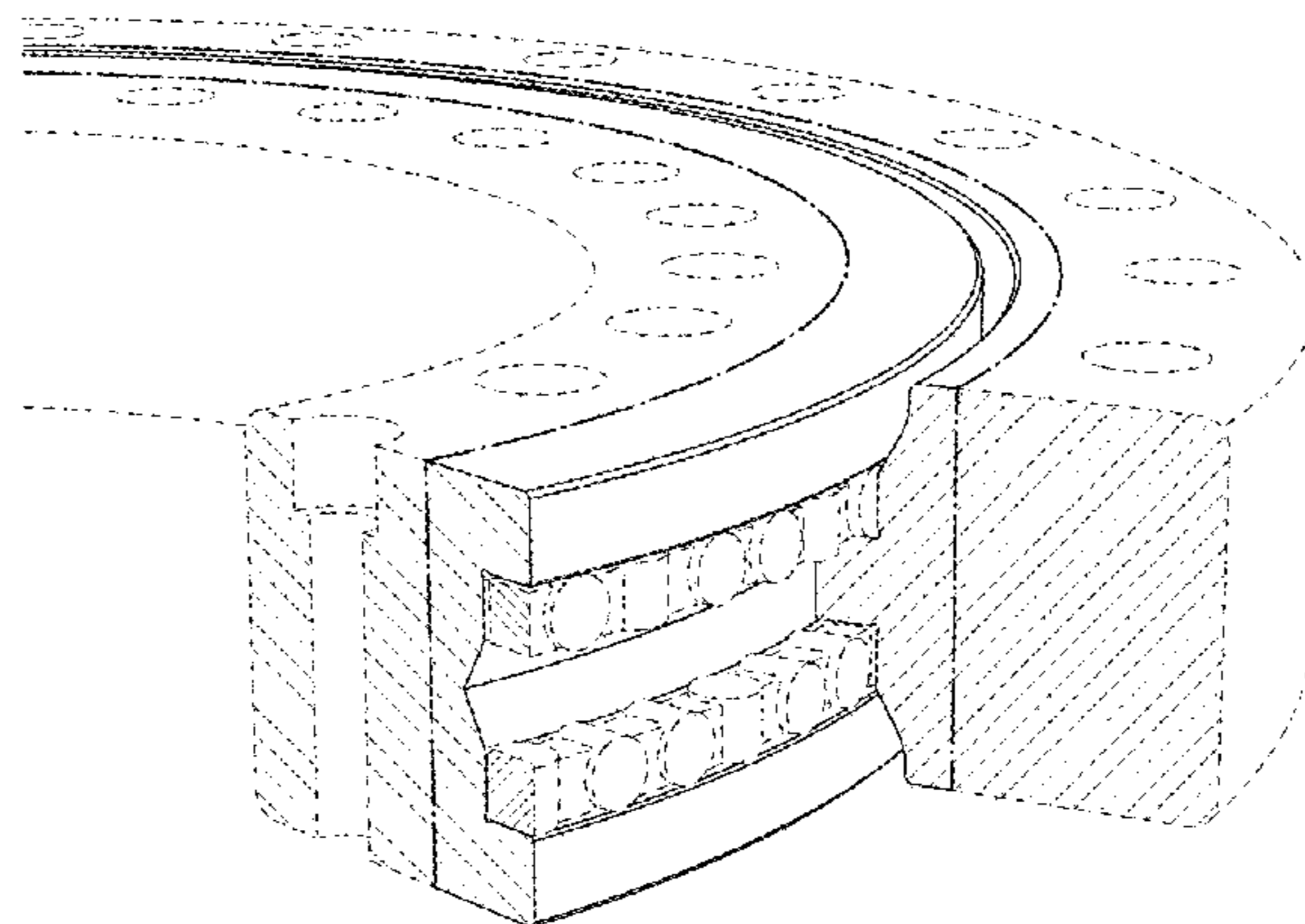

(56)

References Cited

U.S. PATENT DOCUMENTS

4,905,366 A * 3/1990 Warner F16J 15/348
29/404
5,255,985 A * 10/1993 Alling F16C 33/546
384/470
5,626,426 A * 5/1997 Honda F16C 23/086
384/568
6,102,580 A * 8/2000 Alling F16C 19/30
384/470
D444,802 S * 7/2001 Dyson D15/143
6,513,987 B2 * 2/2003 Takahashi F16C 33/4682
384/574
6,883,968 B2 * 4/2005 Fugel F16C 33/546
384/577
7,220,060 B2 * 5/2007 Kono F16C 33/46
384/572
7,722,257 B2 * 5/2010 Tabata F16C 19/364
384/571
8,303,191 B2 * 11/2012 Albrecht F16C 19/30
384/572
8,480,307 B2 * 7/2013 Hofmann F16C 19/26
384/568
8,596,873 B2 * 12/2013 Hofmann F16C 19/26
384/491
8,814,437 B2 * 8/2014 Braun B29C 67/0051
29/898.067
D713,434 S * 9/2014 Nishikawa D15/143

8,876,400 B2 * 11/2014 Kanou F16C 19/30
384/620
8,894,294 B2 * 11/2014 Durney F16C 33/6629
384/578
8,985,860 B2 * 3/2015 Honjo F16C 33/4682
384/526
9,033,585 B2 * 5/2015 Hewitt F16C 33/467
384/572
9,039,288 B2 * 5/2015 Takeuchi F16C 33/4635
384/572
2010/0303397 A1 * 12/2010 Draser F16C 19/466
384/572
2010/0322549 A1 * 12/2010 Brown F16C 33/546
384/572

OTHER PUBLICATIONS

Taiwanese Office Action dated Feb. 24, 2015, issued in corresponding TW Patent Application No. 103304200D01 with English translation (5 pages).
Taiwanese Office Action dated Feb. 24, 2015, issued in corresponding TW Patent Application No. 103304200D02 with English translation (5 pages).
Taiwanese Office Action dated Feb. 17, 2015, issued in corresponding TW Patent Application No. 103304200D03 with English translation (5 pages).

* cited by examiner

FIG. 1

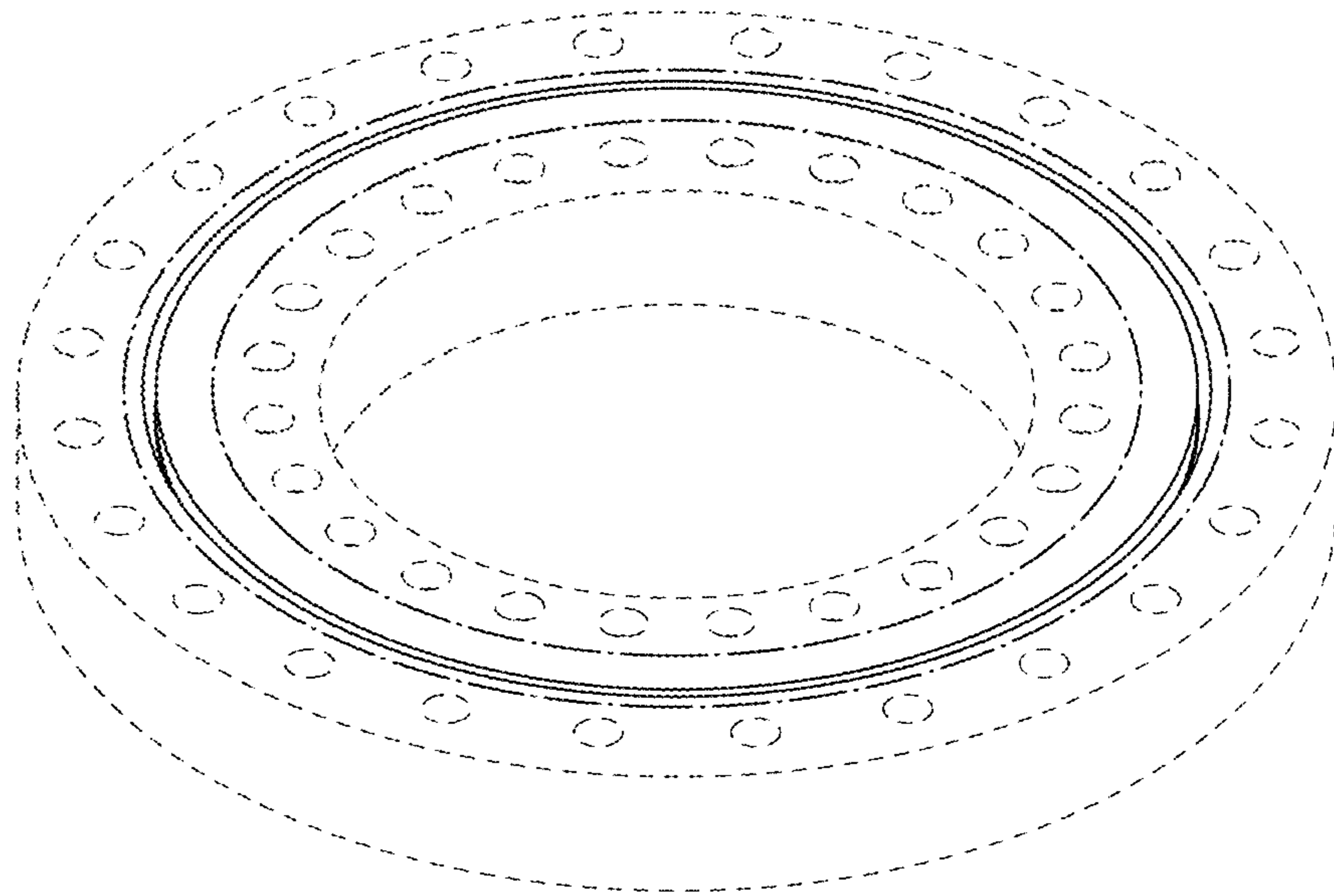

FIG. 2

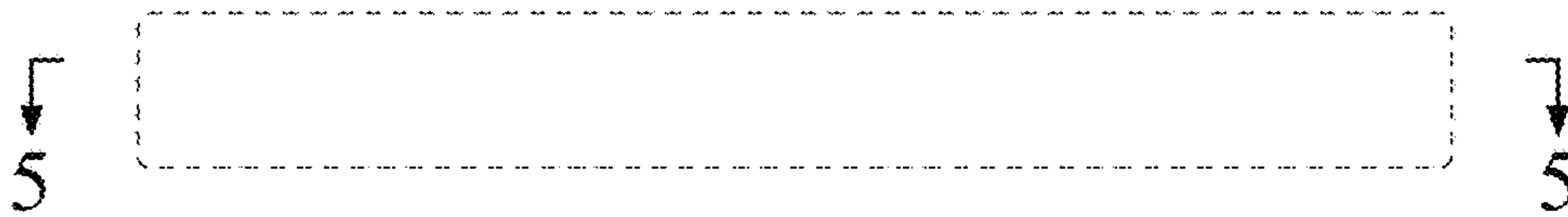

FIG. 3

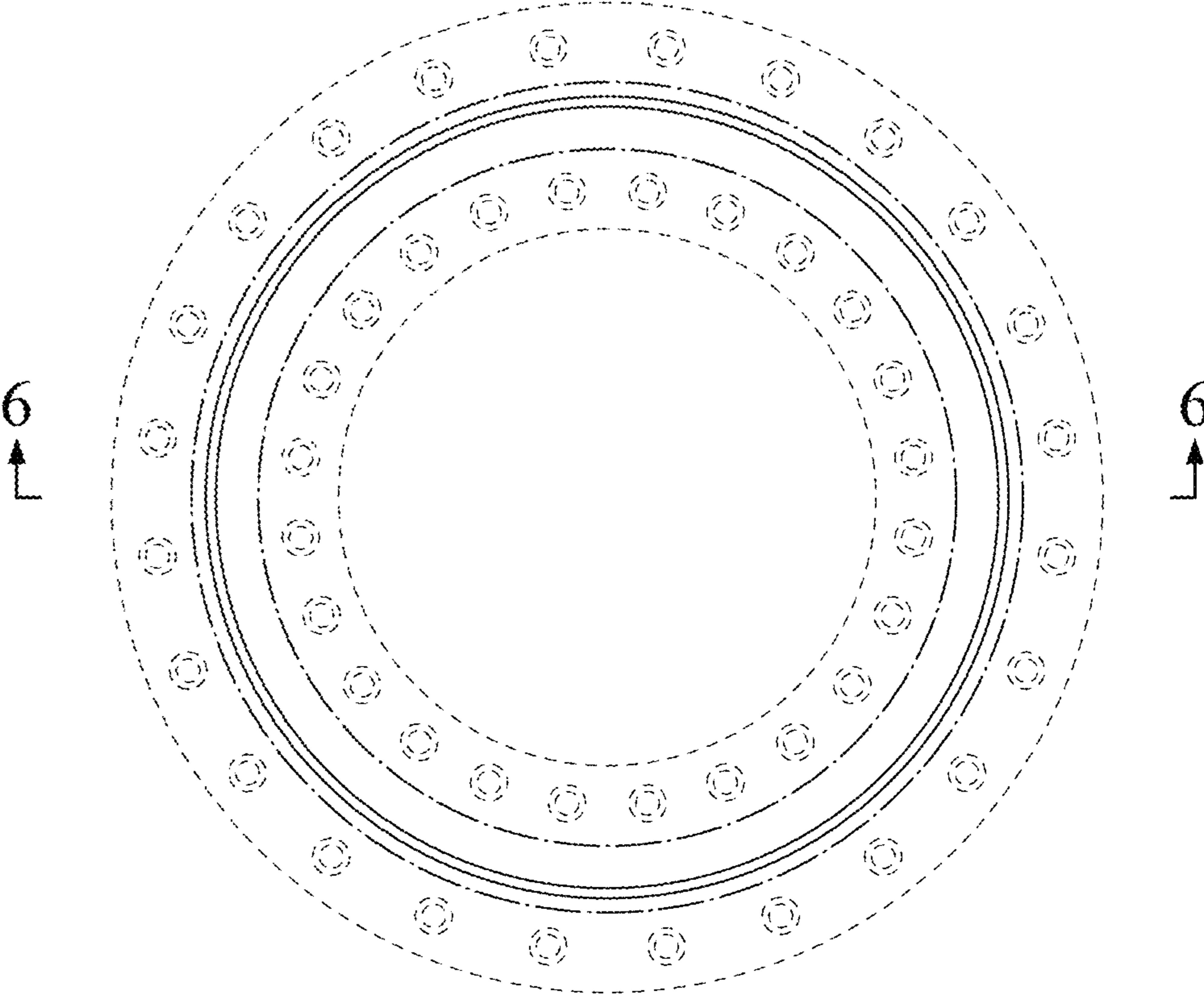

FIG. 4

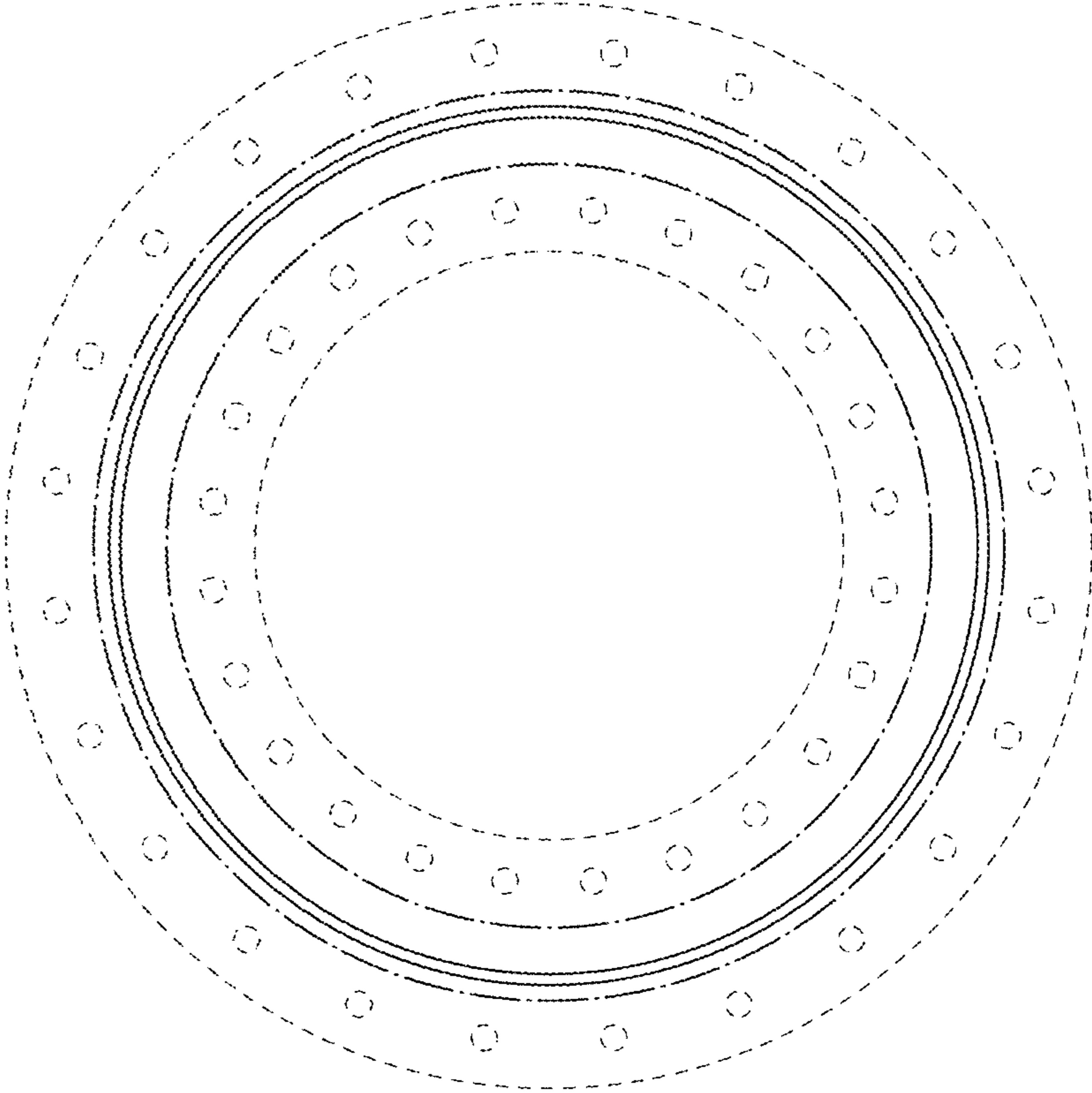

FIG. 5

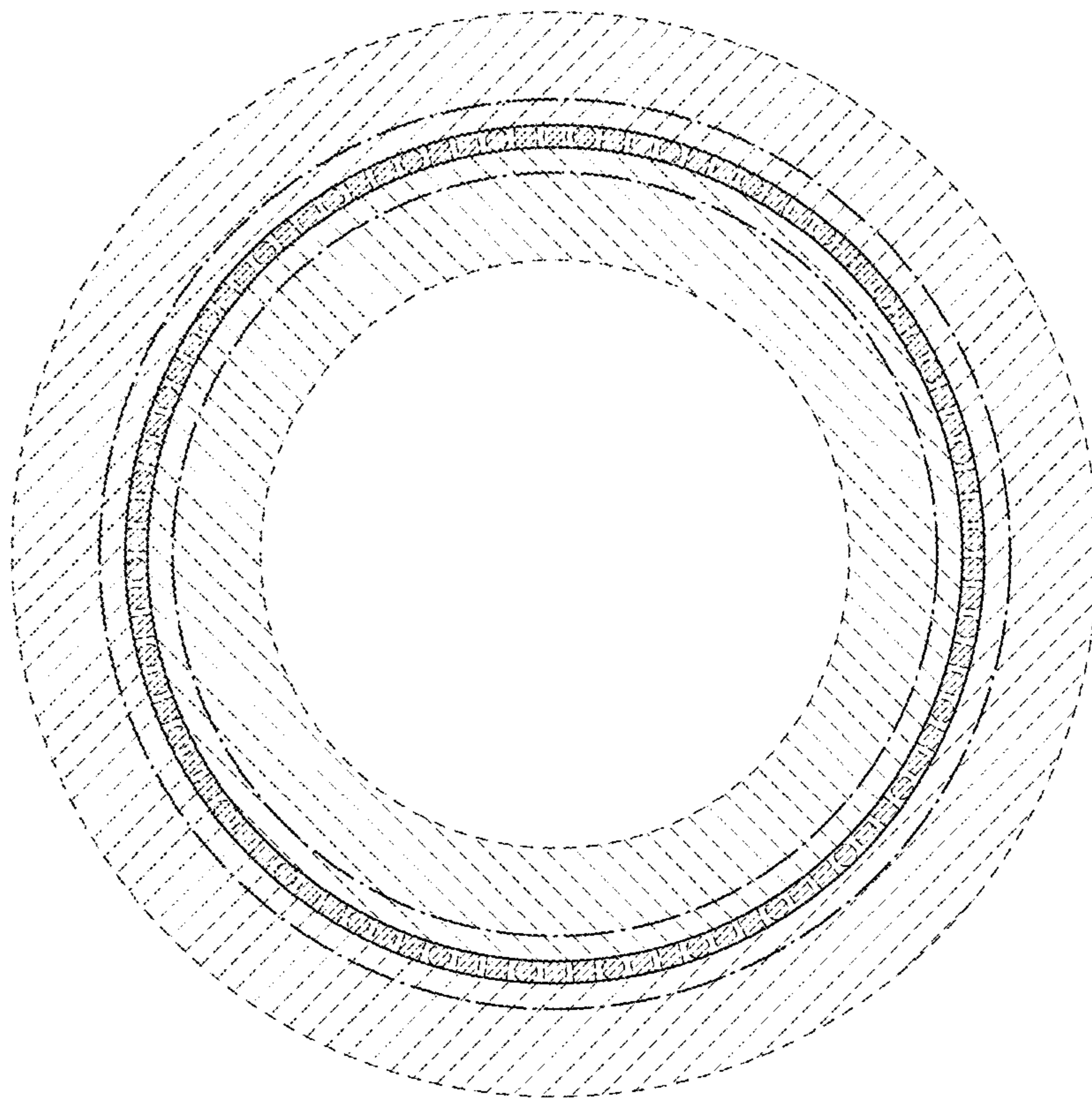

FIG. 6



FIG. 7

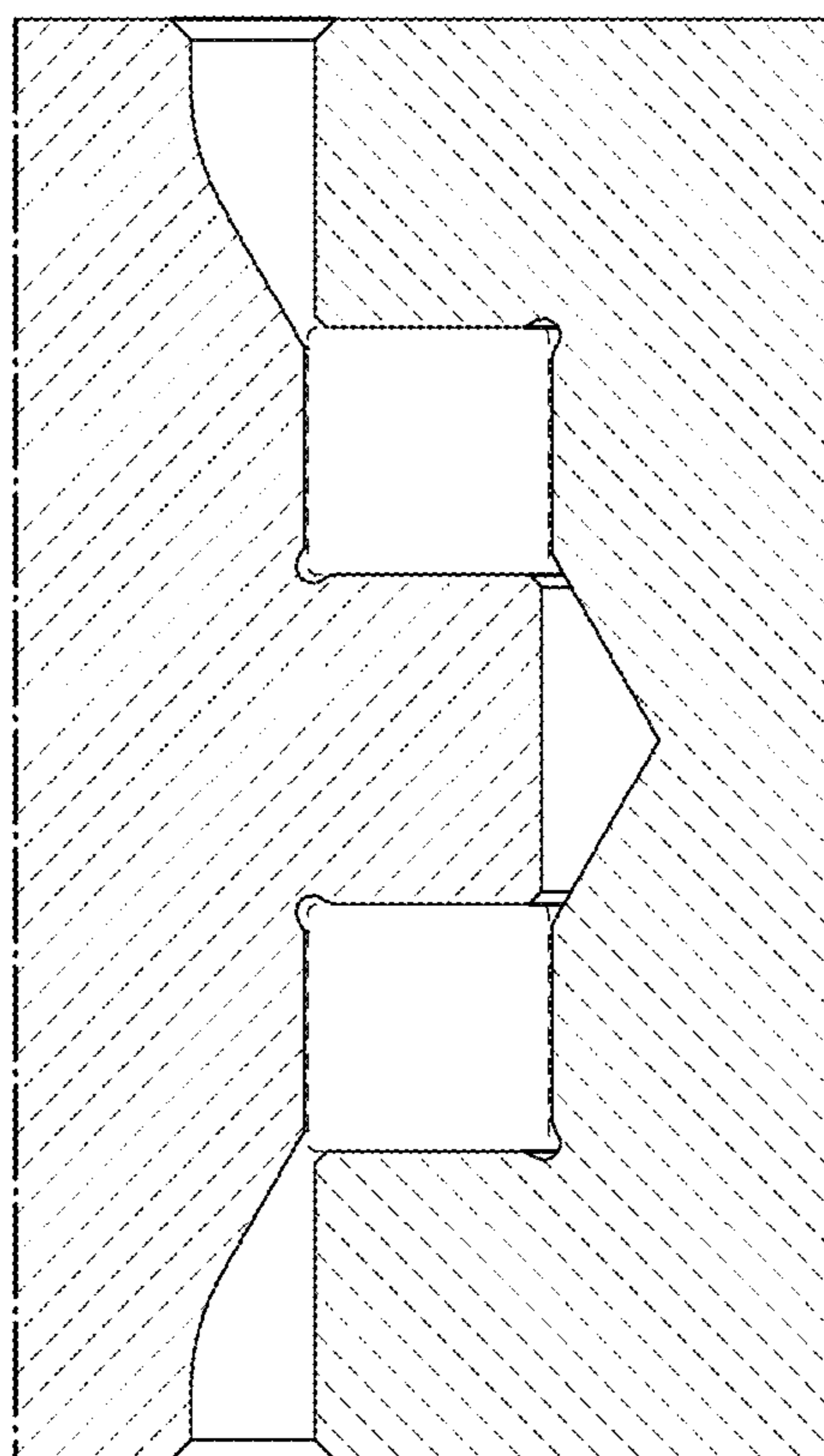

FIG. 8

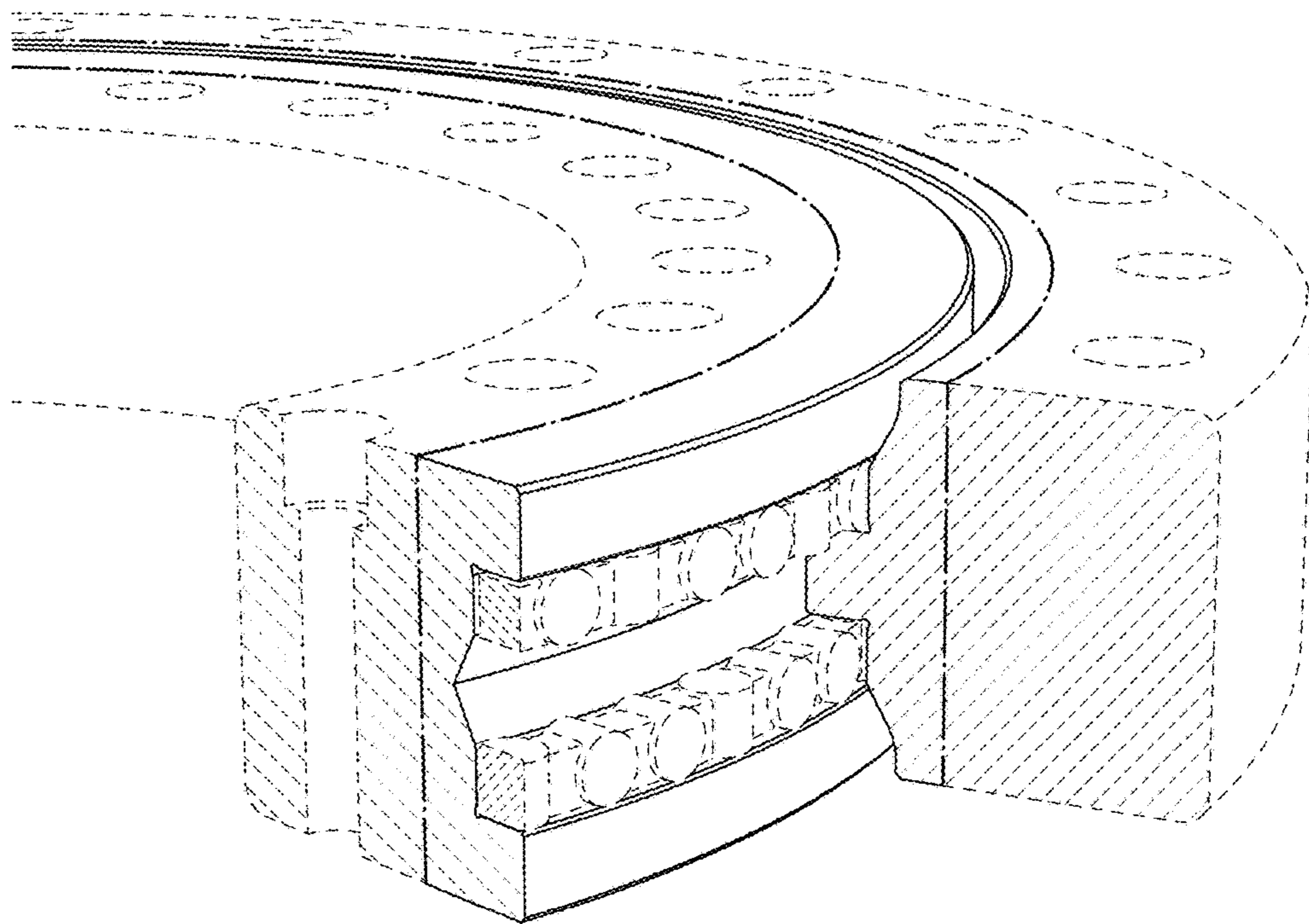

FIG. 9

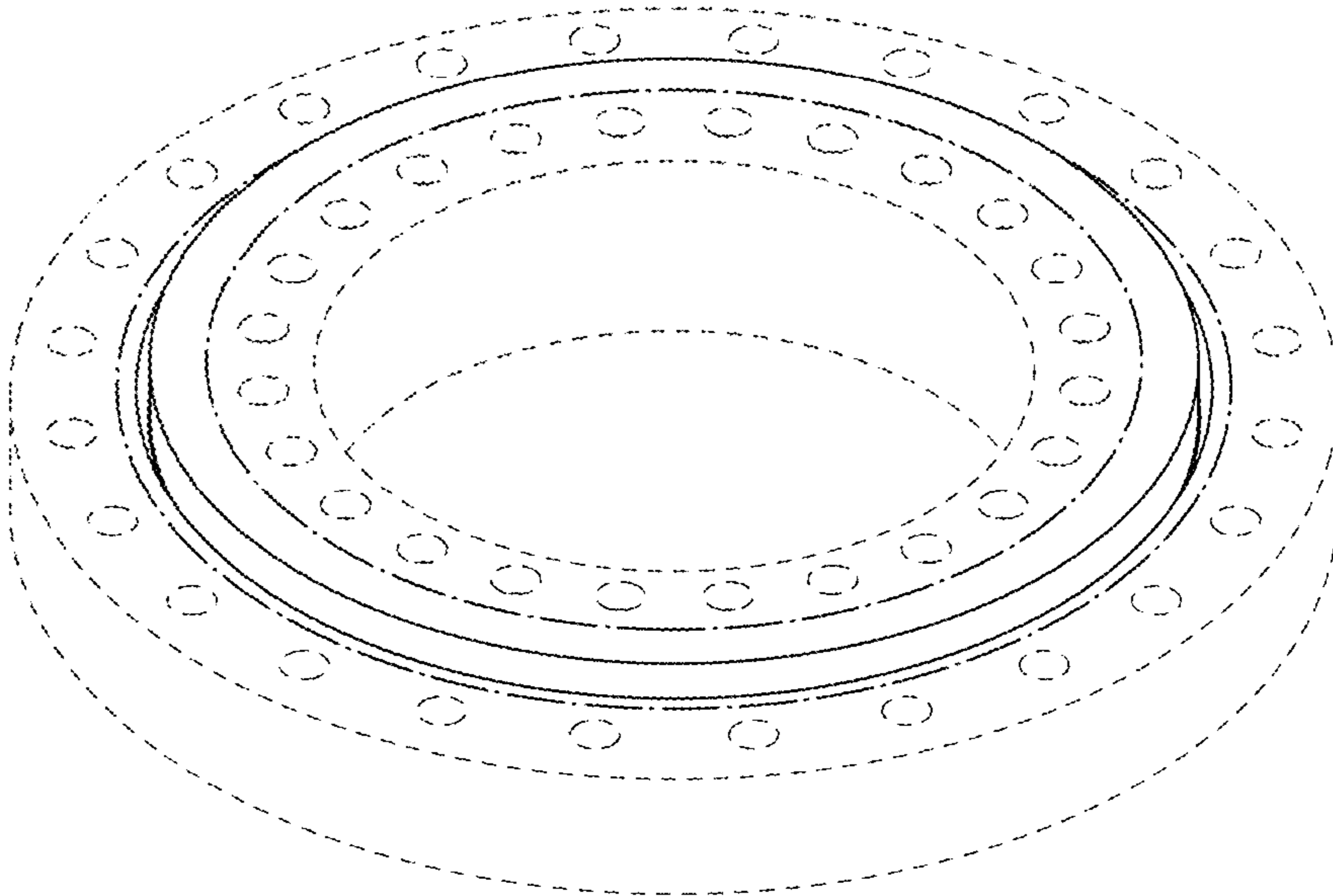

FIG. 10

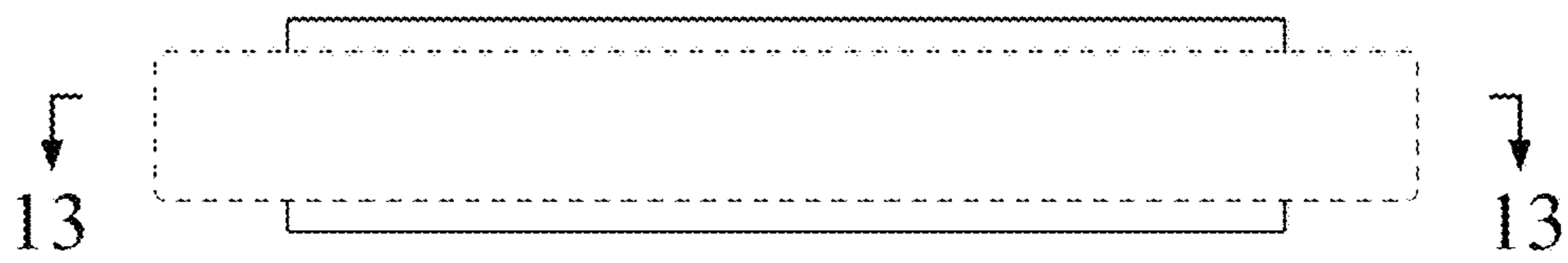

FIG. 11

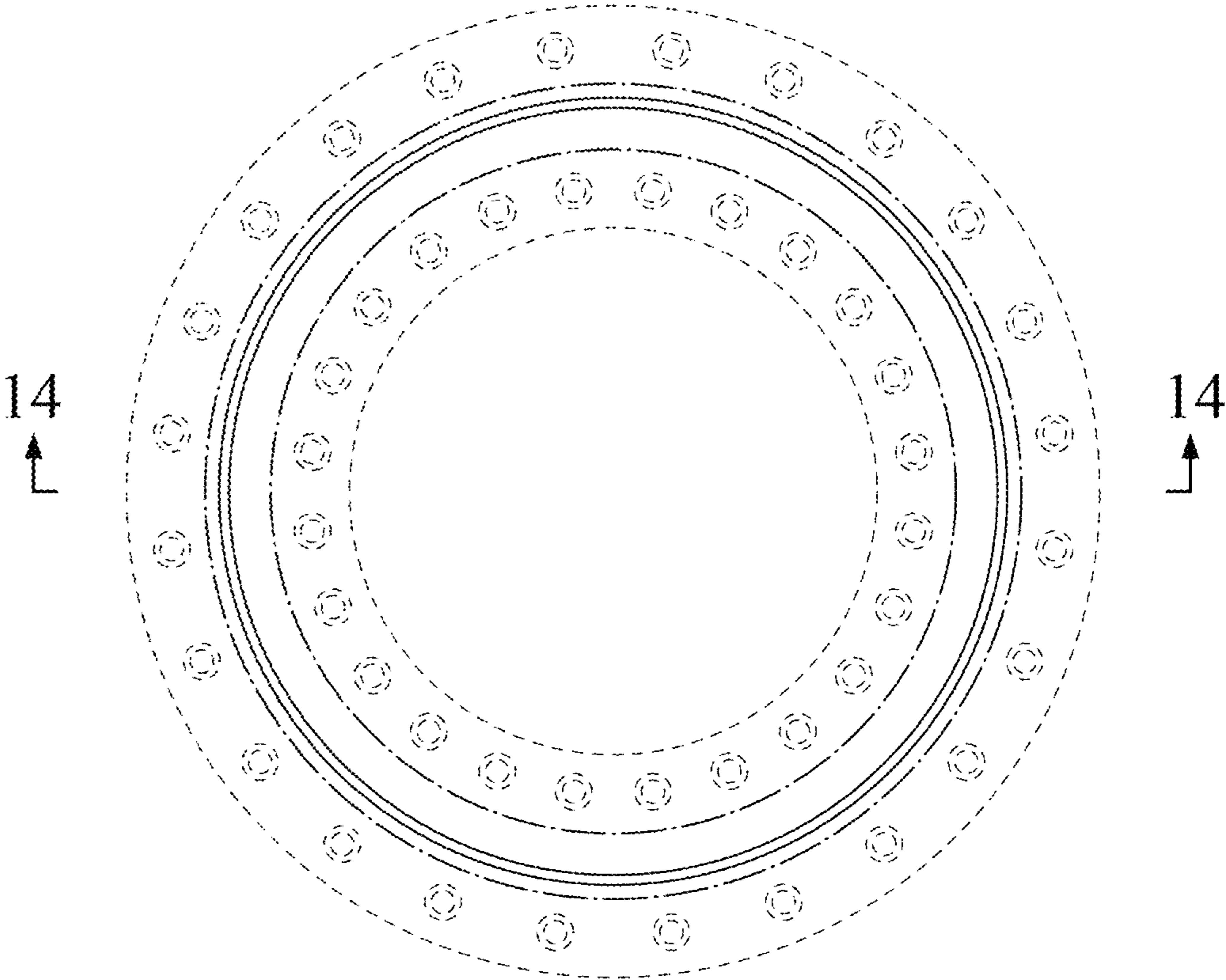

FIG. 12

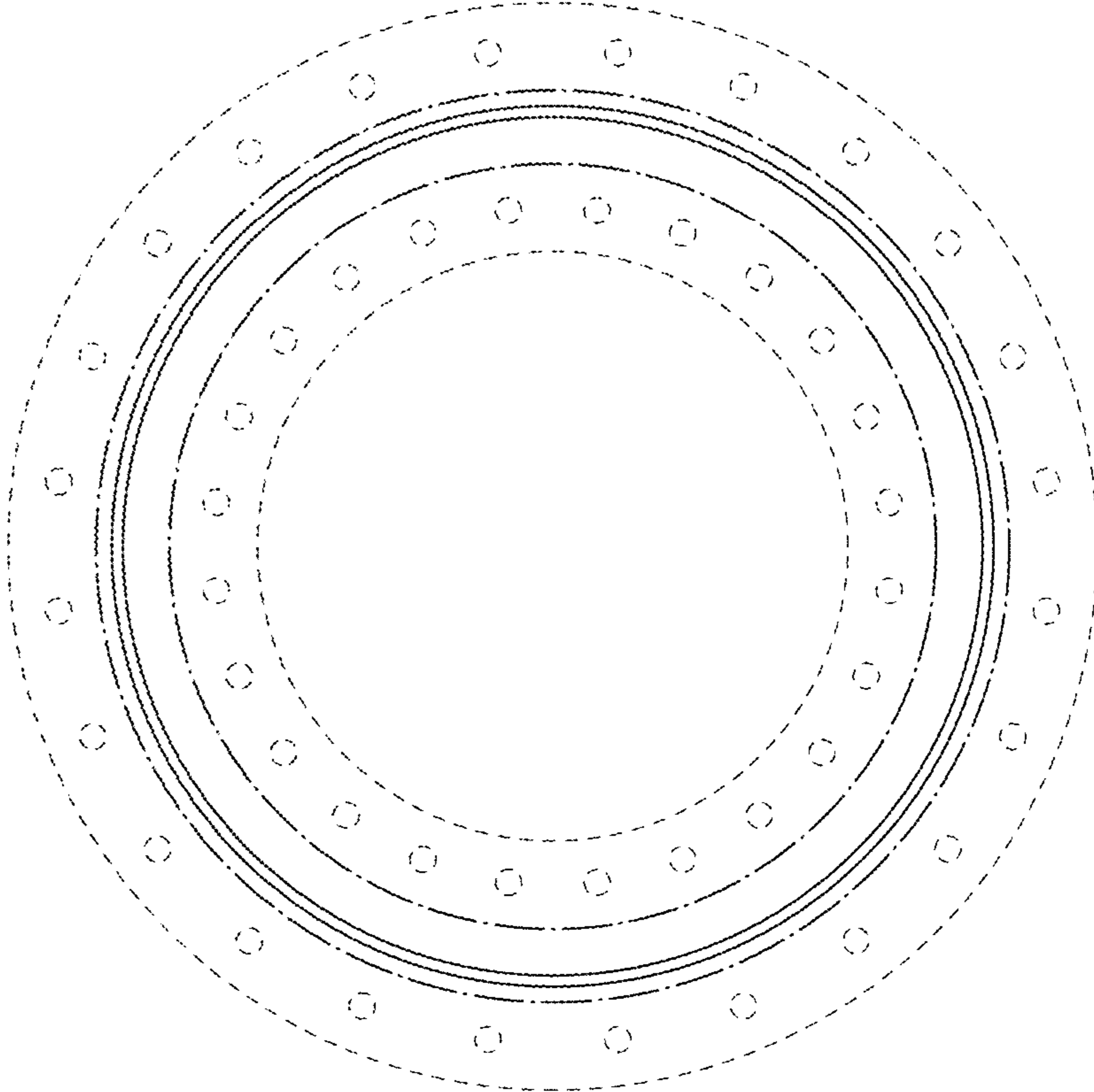

FIG. 13

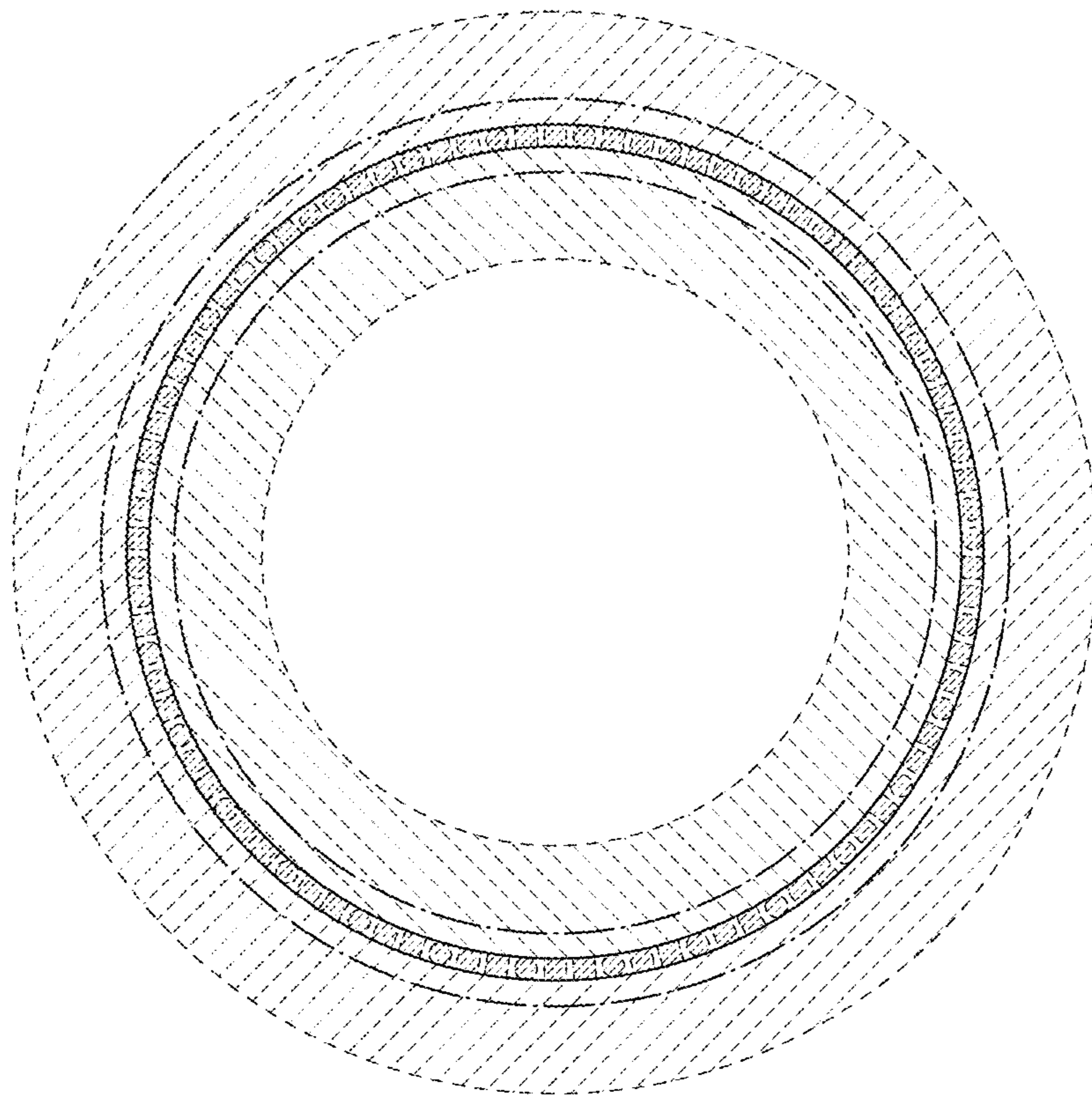

FIG. 14



FIG. 15

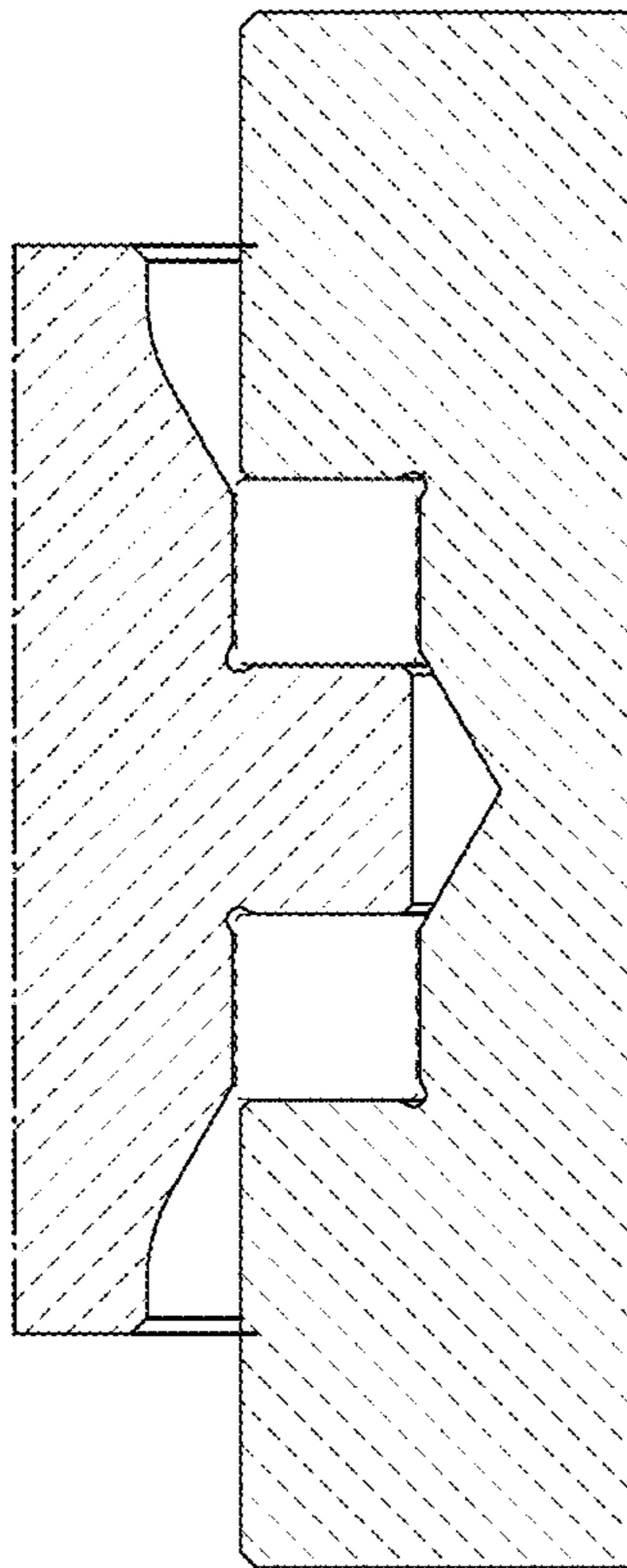

FIG. 16

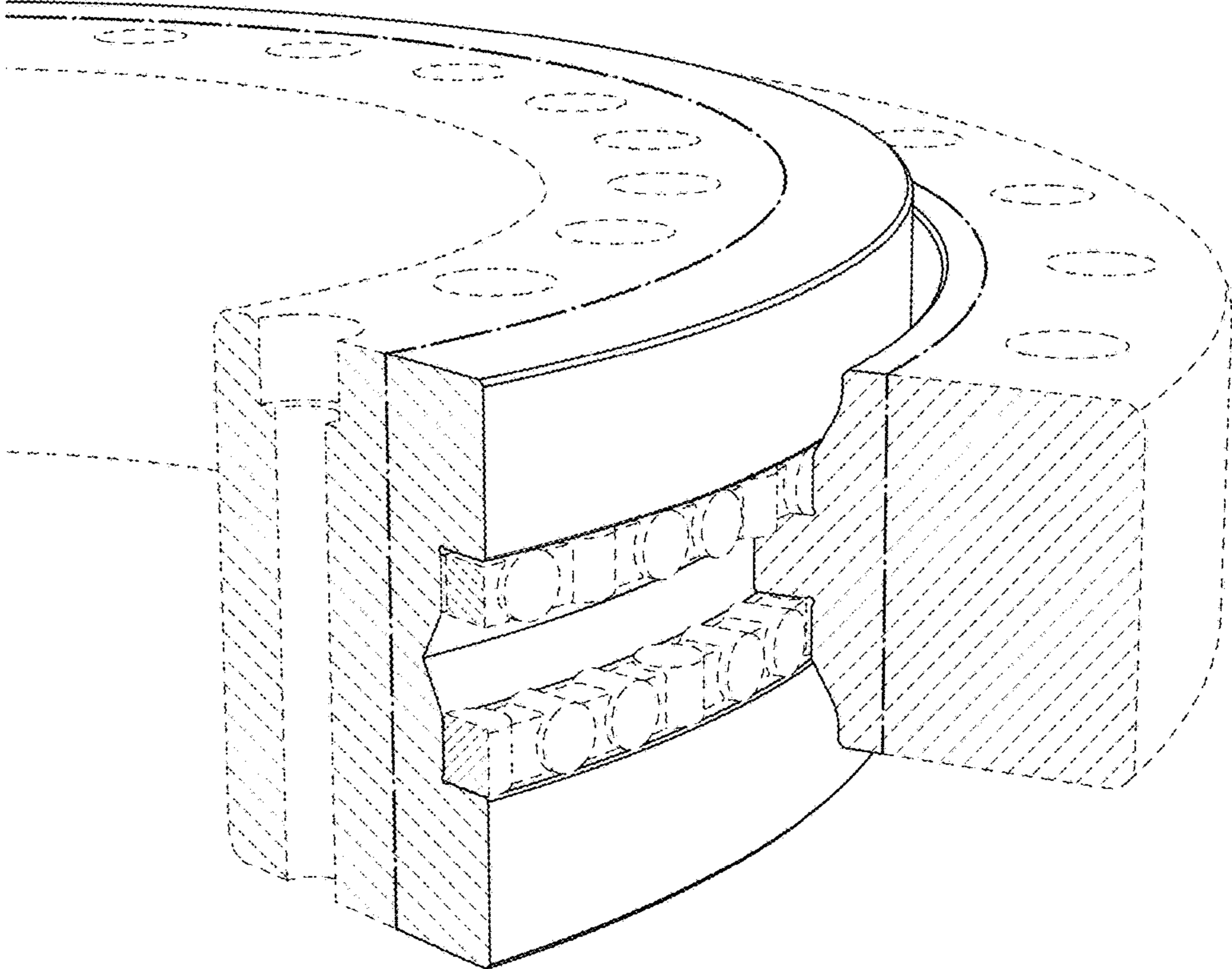

FIG. 17

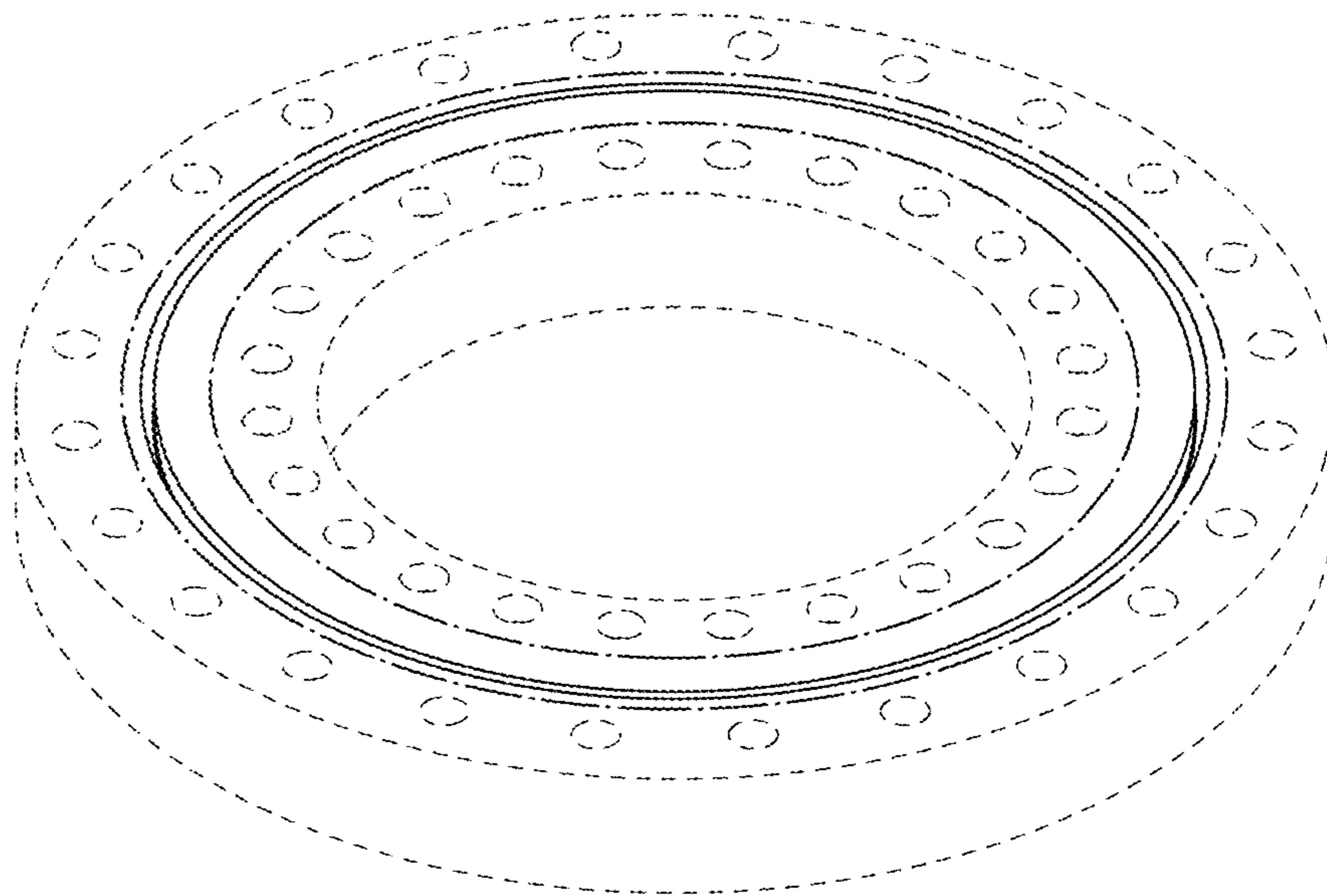

FIG. 18

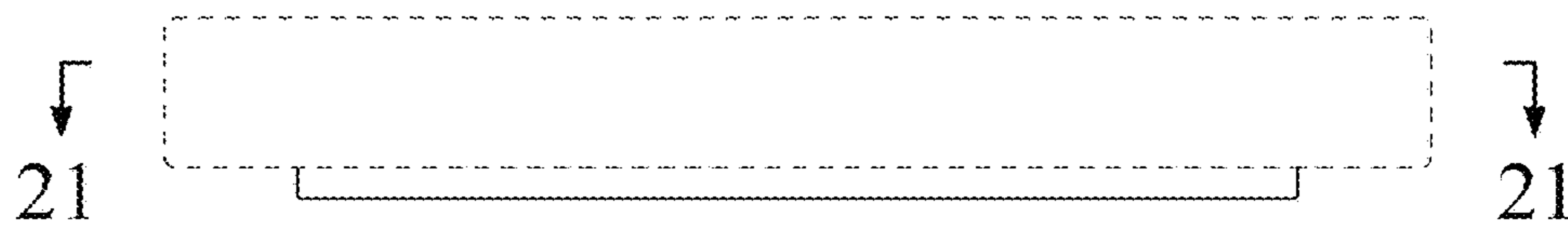

FIG. 19

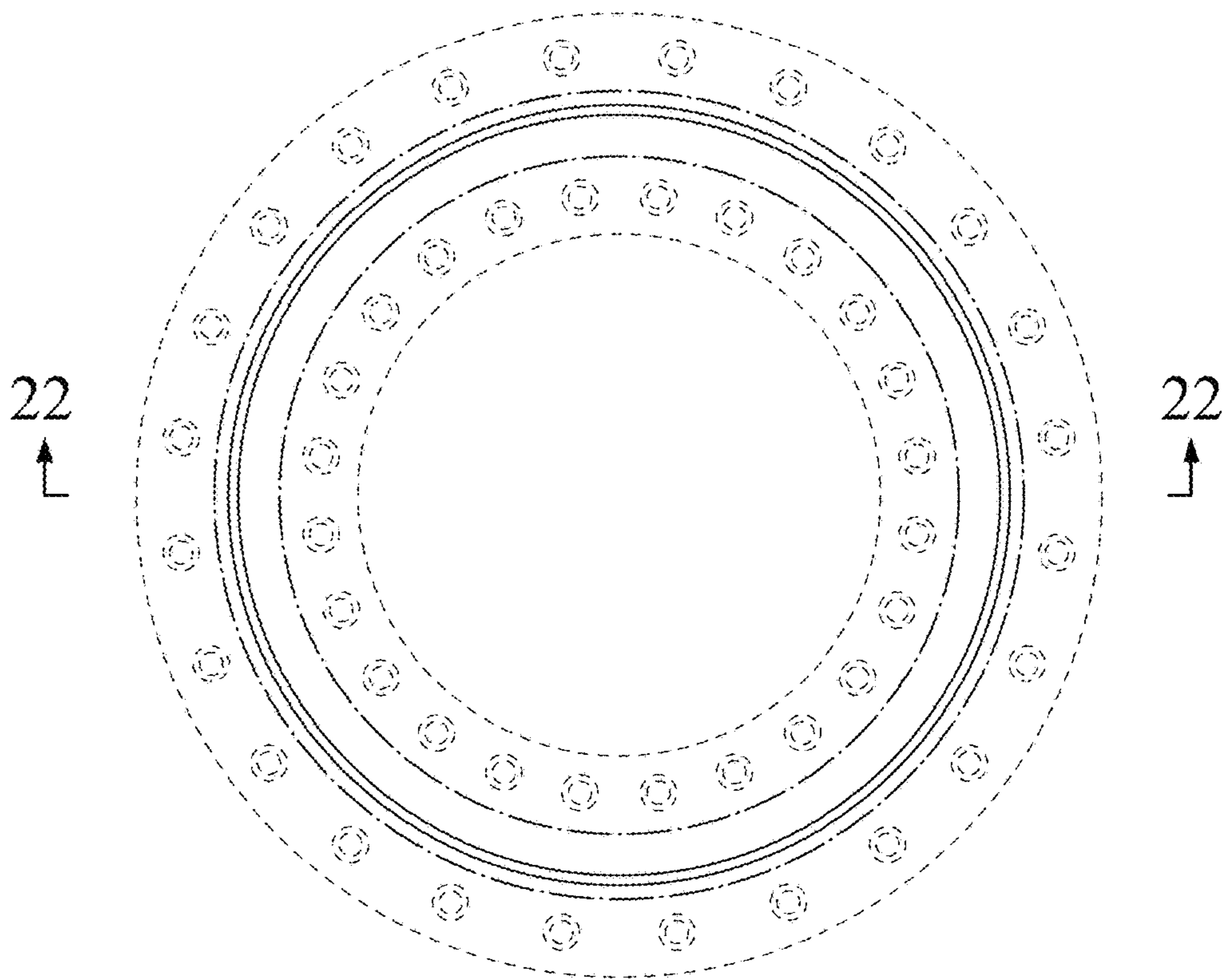

FIG. 20

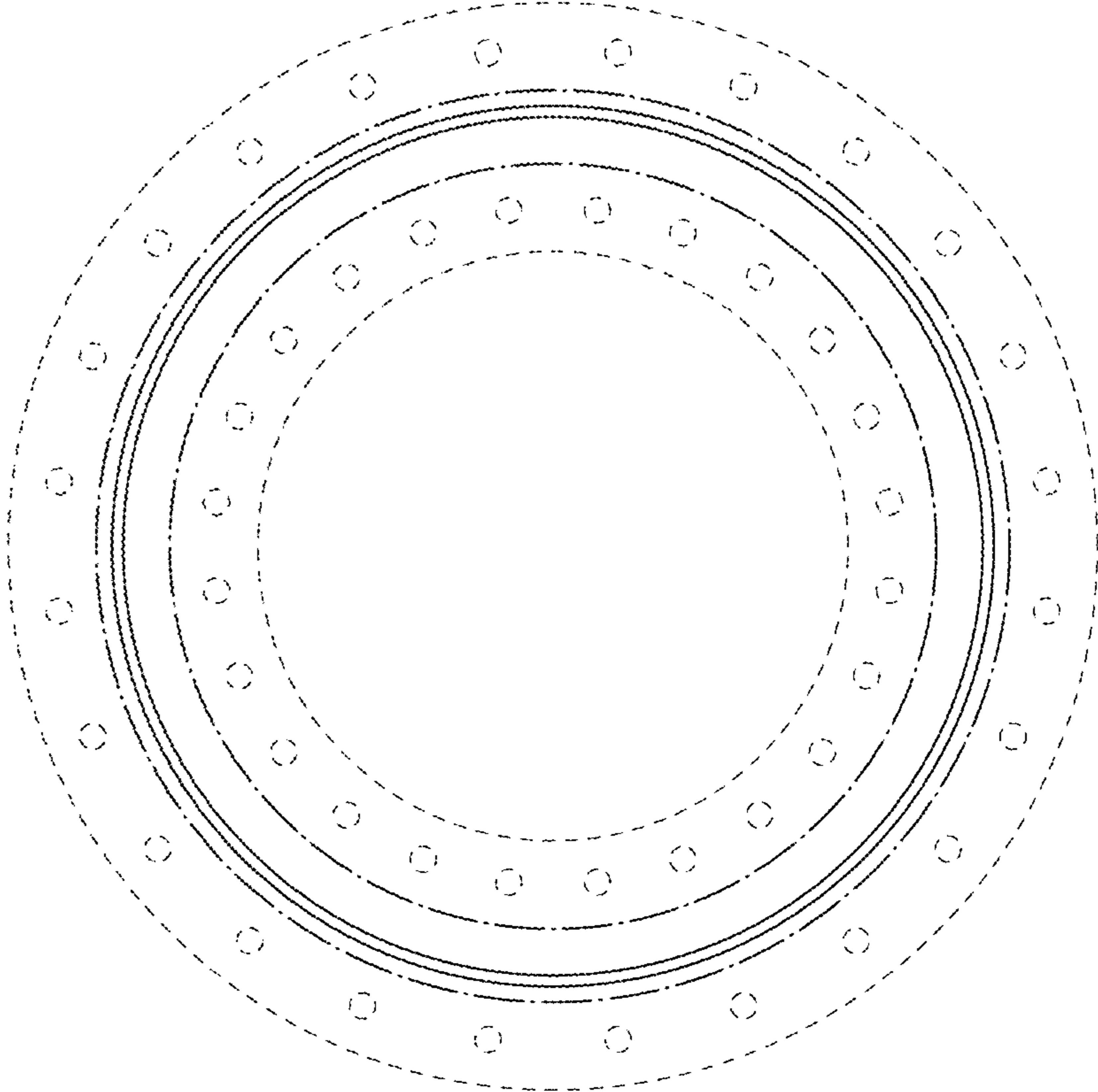

FIG. 21

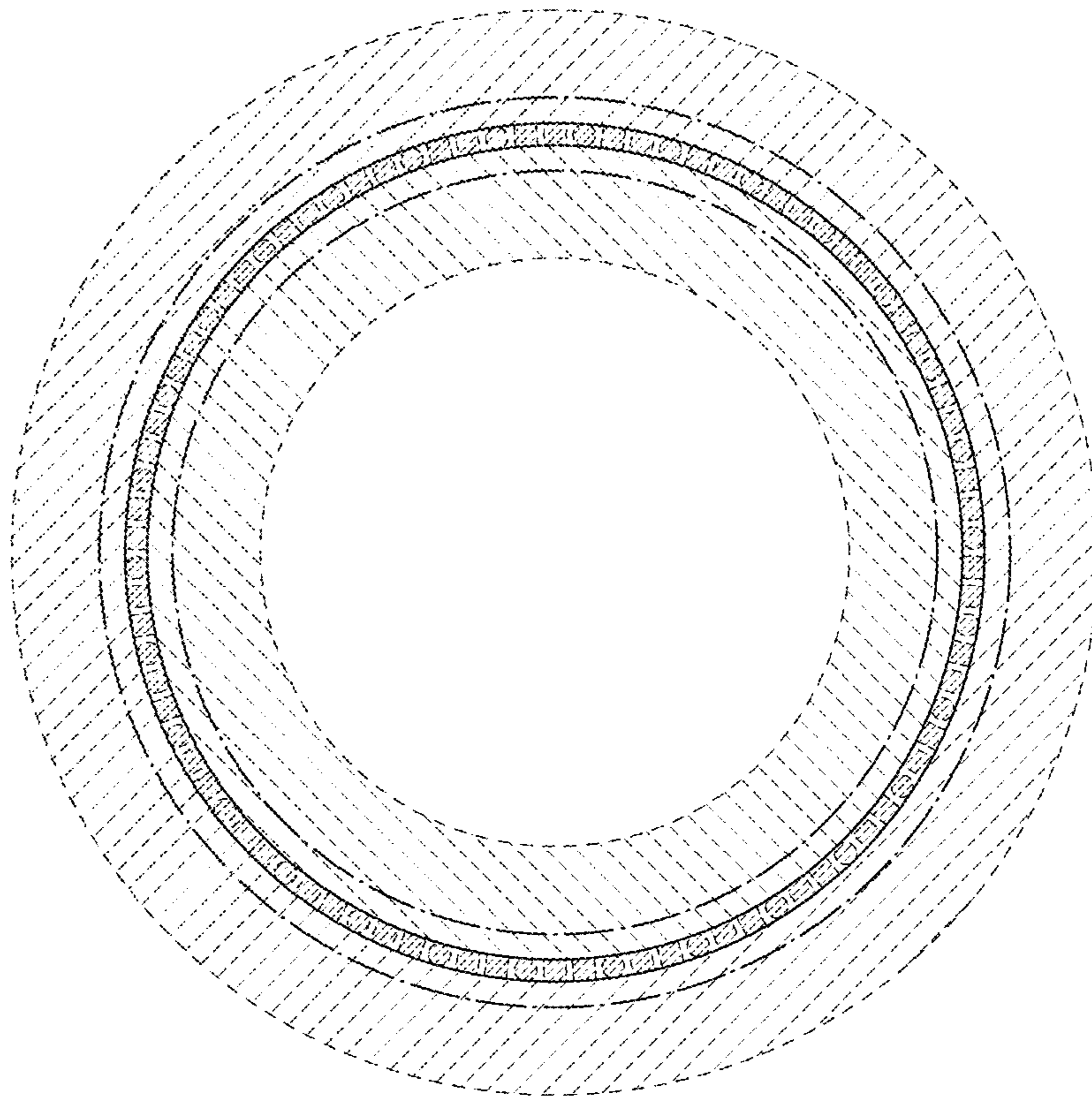

FIG. 22



FIG. 23

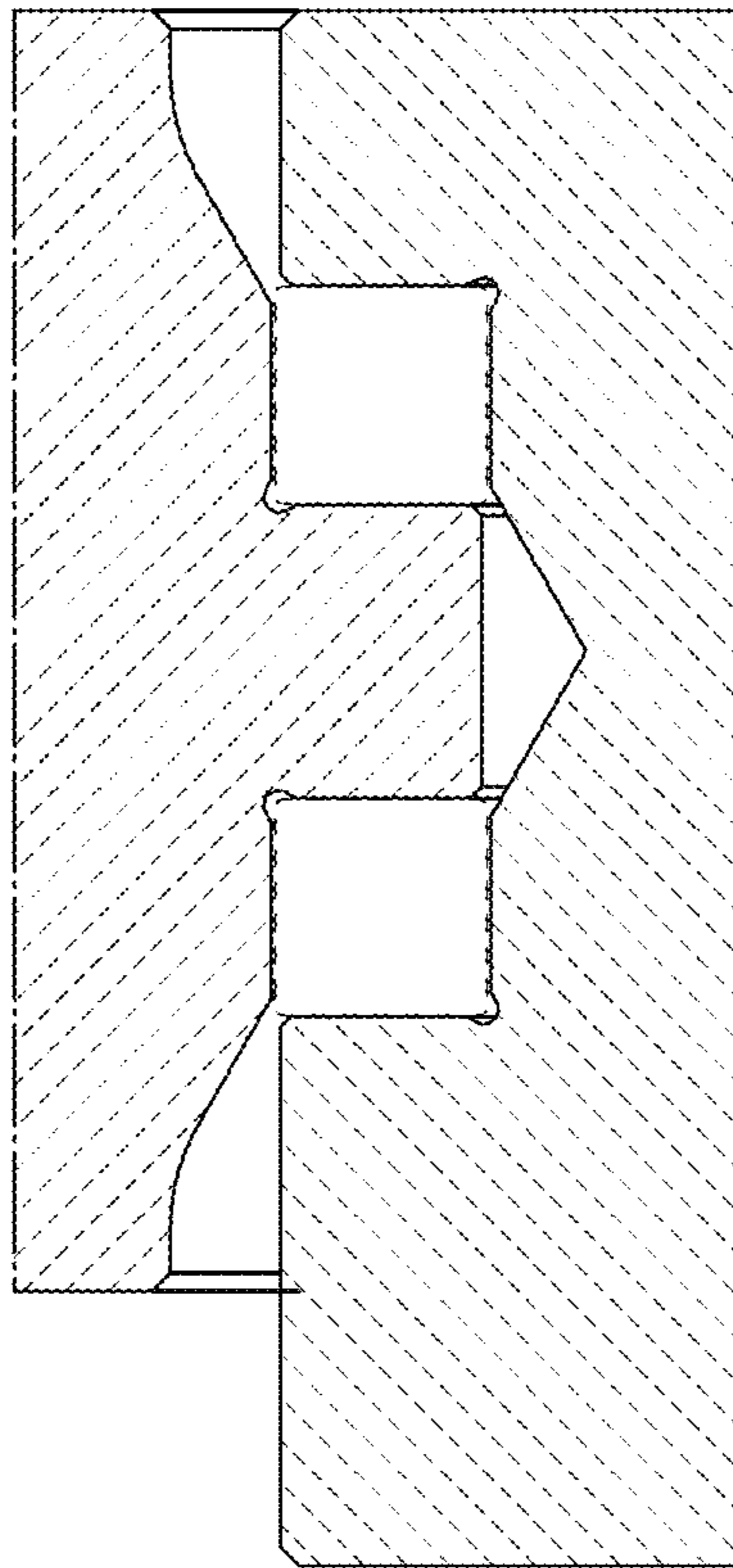

FIG. 24

