



US00D772775S

(12) **United States Design Patent**
Bird et al.

(10) **Patent No.:** **US D772,775 S**

(45) **Date of Patent:** **** Nov. 29, 2016**

(54) **WHEEL CHOCK HAVING A ROLLER ASSIST**

(71) Applicants: **Steve K. Bird**, St. Louis, MO (US);
Robert Bales, St. Louis, MO (US)

(72) Inventors: **Steve K. Bird**, St. Louis, MO (US);
Robert Bales, St. Louis, MO (US)

(**) Term: **15 Years**

(21) Appl. No.: **29/539,104**

(22) Filed: **Sep. 10, 2015**

(51) **LOC (10) Cl.** **12-06**

(52) **U.S. Cl.**
USPC **D12/223**

(58) **Field of Classification Search**
USPC D12/223, 400, 174, 179, 180, 217, 106;
D8/71
CPC B60T 3/00; B65G 69/005; B65G 69/00;
B65G 69/003

See application file for complete search history.

(56) **References Cited**

U.S. PATENT DOCUMENTS

- 1,617,369 A * 2/1927 Blakely B60P 3/077
188/32
- 2,189,323 A * 2/1940 Noonan B60T 3/00
188/32
- 3,065,827 A * 11/1962 Timbers B60T 3/00
188/32
- 3,305,049 A * 2/1967 Willey B60T 3/00
188/32
- D316,243 S * 4/1991 Henry D12/217

- 5,689,981 A * 11/1997 DeLuca B60R 25/09
188/32
- D409,133 S * 5/1999 Henry D12/217
- 6,336,527 B1 * 1/2002 Metz B60T 3/00
188/32
- 6,390,245 B1 * 5/2002 Metz B60T 3/00
188/32
- D552,527 S * 10/2007 Wolfram D12/217
- D609,158 S 2/2010 Bird
- 2008/0277211 A1 * 11/2008 Wolfram B60T 3/00
188/32
- 2011/0100765 A1 * 5/2011 Bird B60T 3/00
188/32

* cited by examiner

Primary Examiner — Sandra Snapp

Assistant Examiner — Ieisha Price

(74) *Attorney, Agent, or Firm* — Kevin L. Klug

(57) **CLAIM**

The ornamental design for a wheel chock having a roller assist, as shown.

DESCRIPTION

FIG. 1 is a front left perspective view of a wheel chock having a roller assist;
 FIG. 2 is a front right perspective view thereof;
 FIG. 3 is a front left bottom perspective view thereof;
 FIG. 4 is a rear right bottom perspective view thereof;
 FIG. 5 is a front elevation view thereof;
 FIG. 6 is a left elevation view thereof;
 FIG. 7 is a right elevation view thereof;
 FIG. 8 is a bottom plan view thereof;
 FIG. 9 is a top plan view thereof; and,
 FIG. 10 is a rear elevation view thereof.

1 Claim, 10 Drawing Sheets

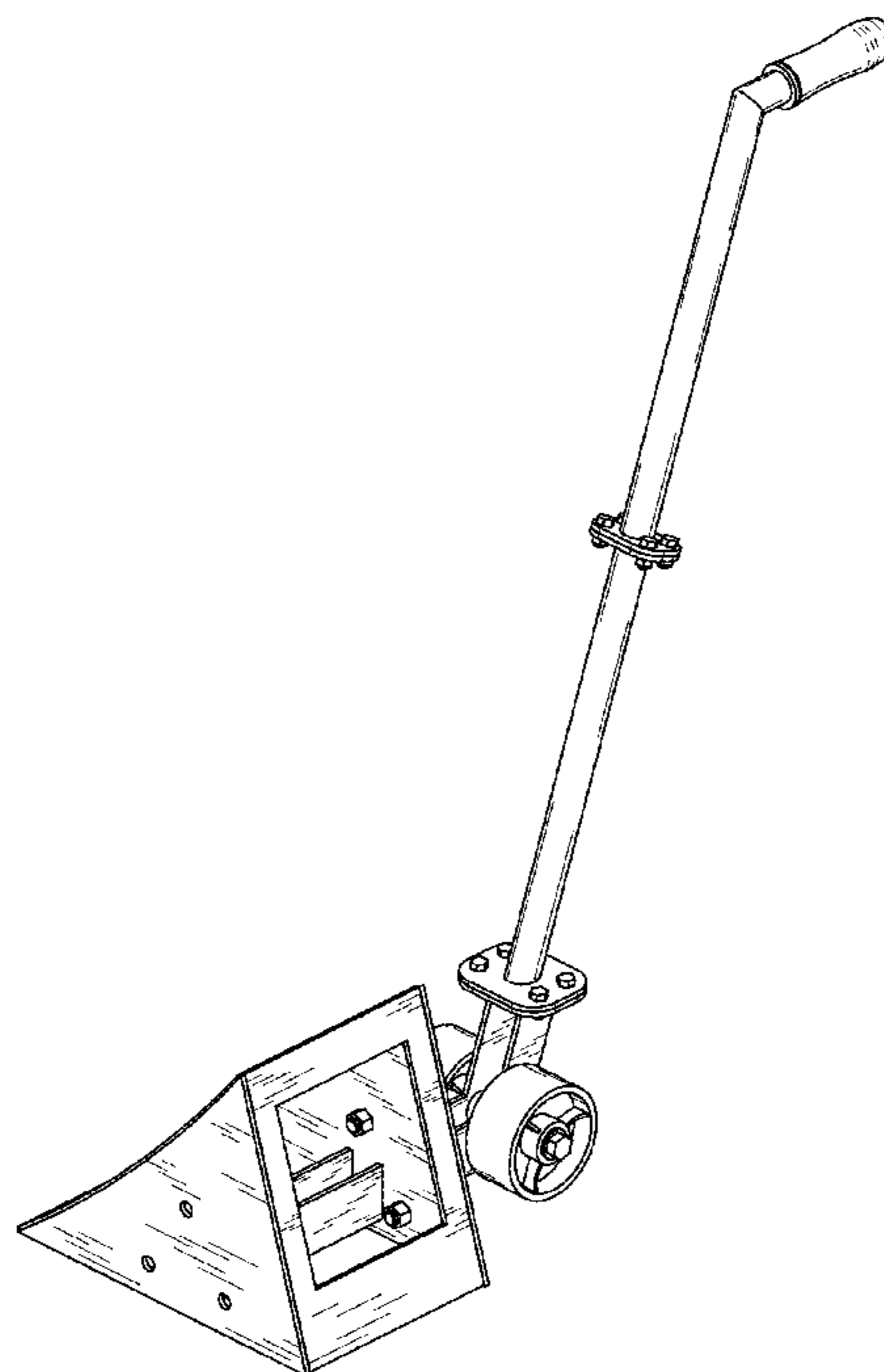

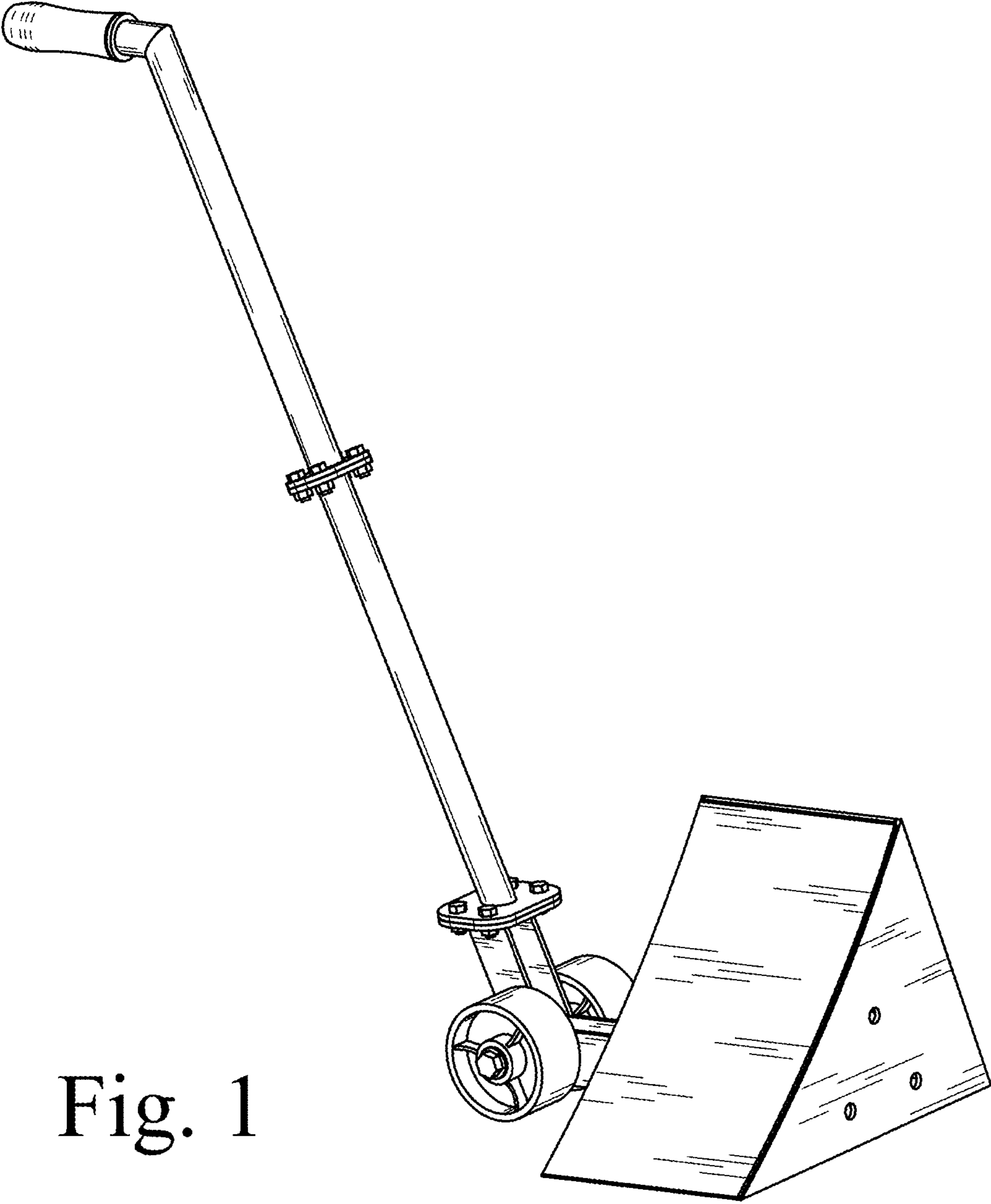

Fig. 1

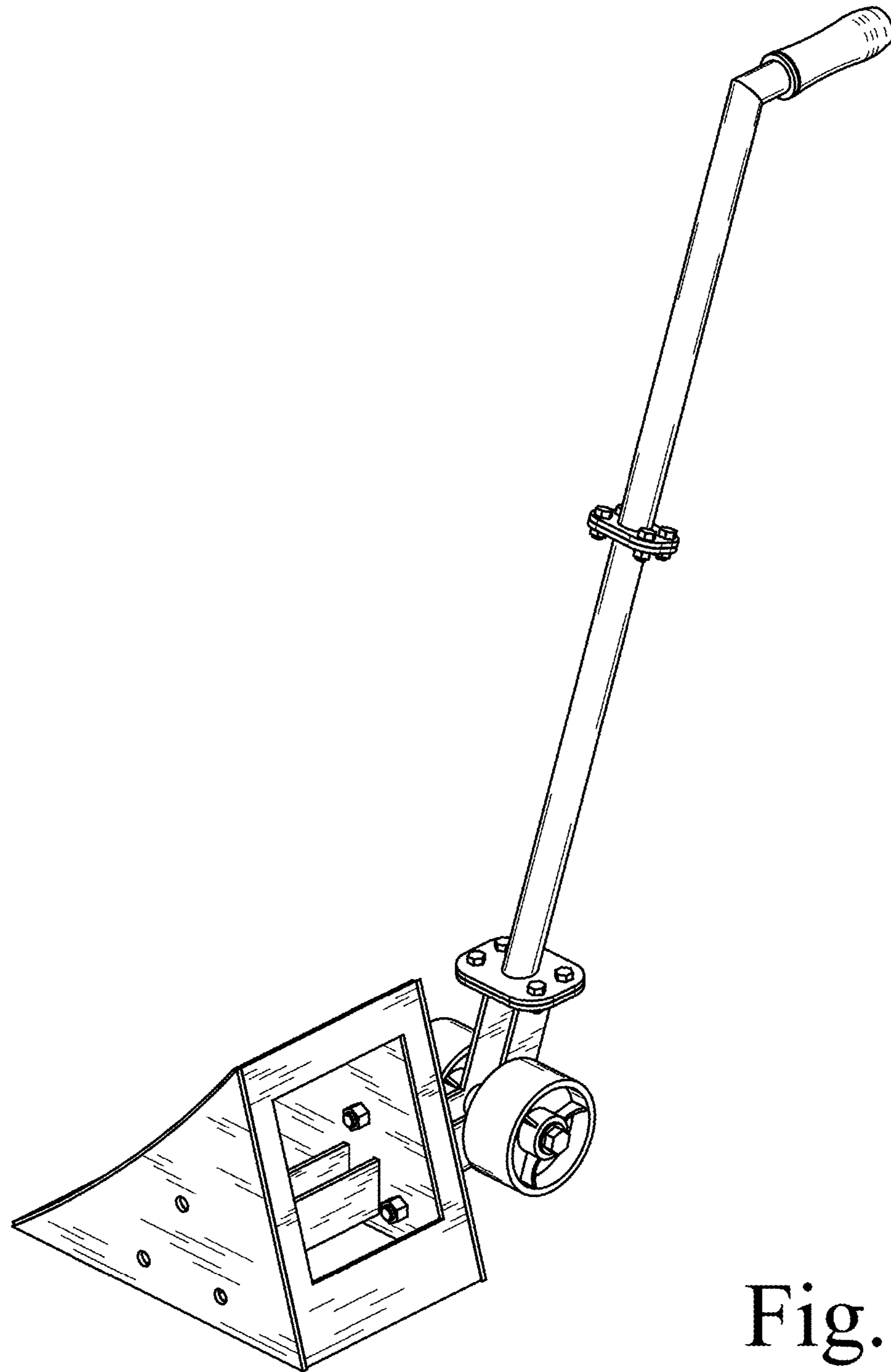

Fig. 2

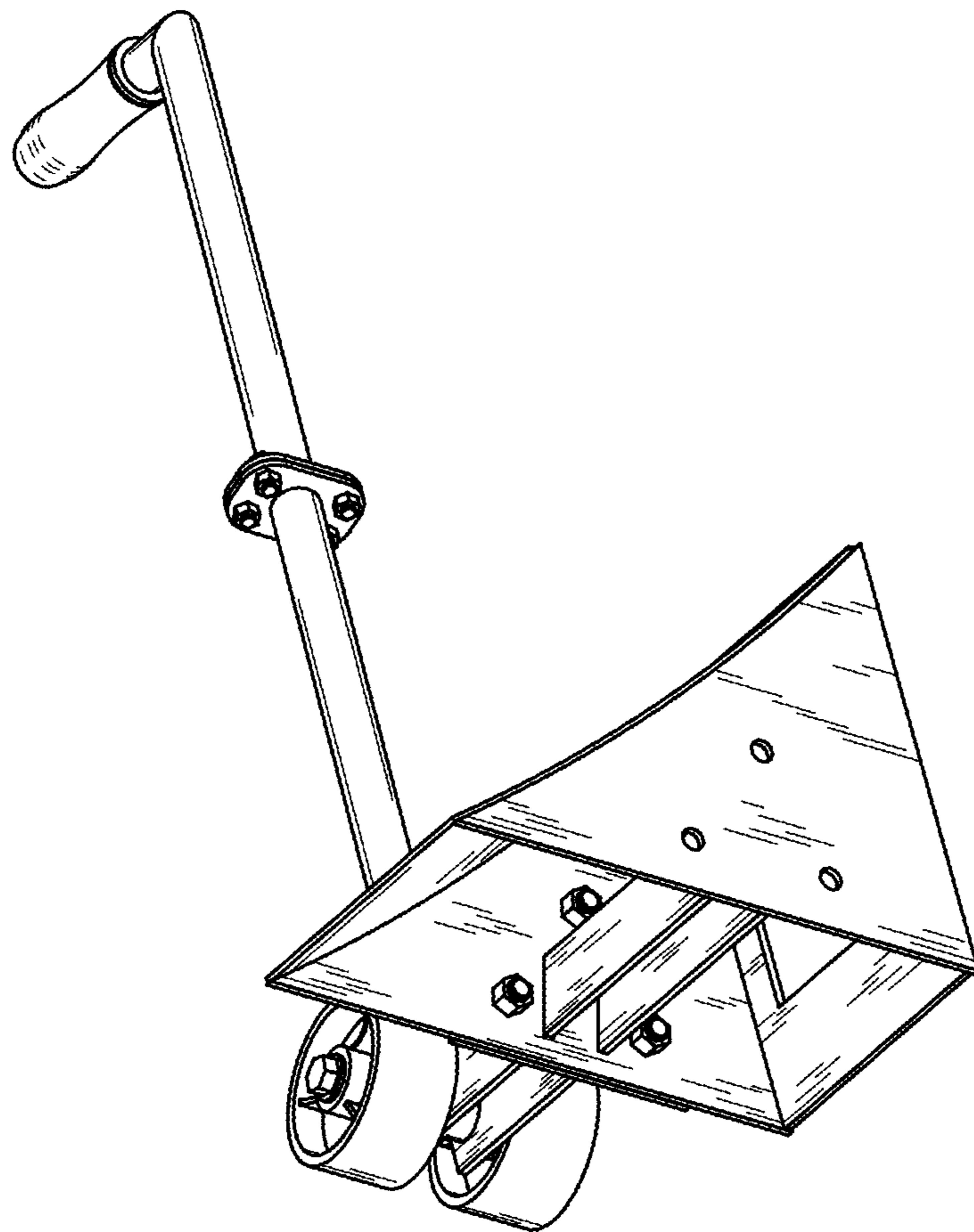

Fig. 3

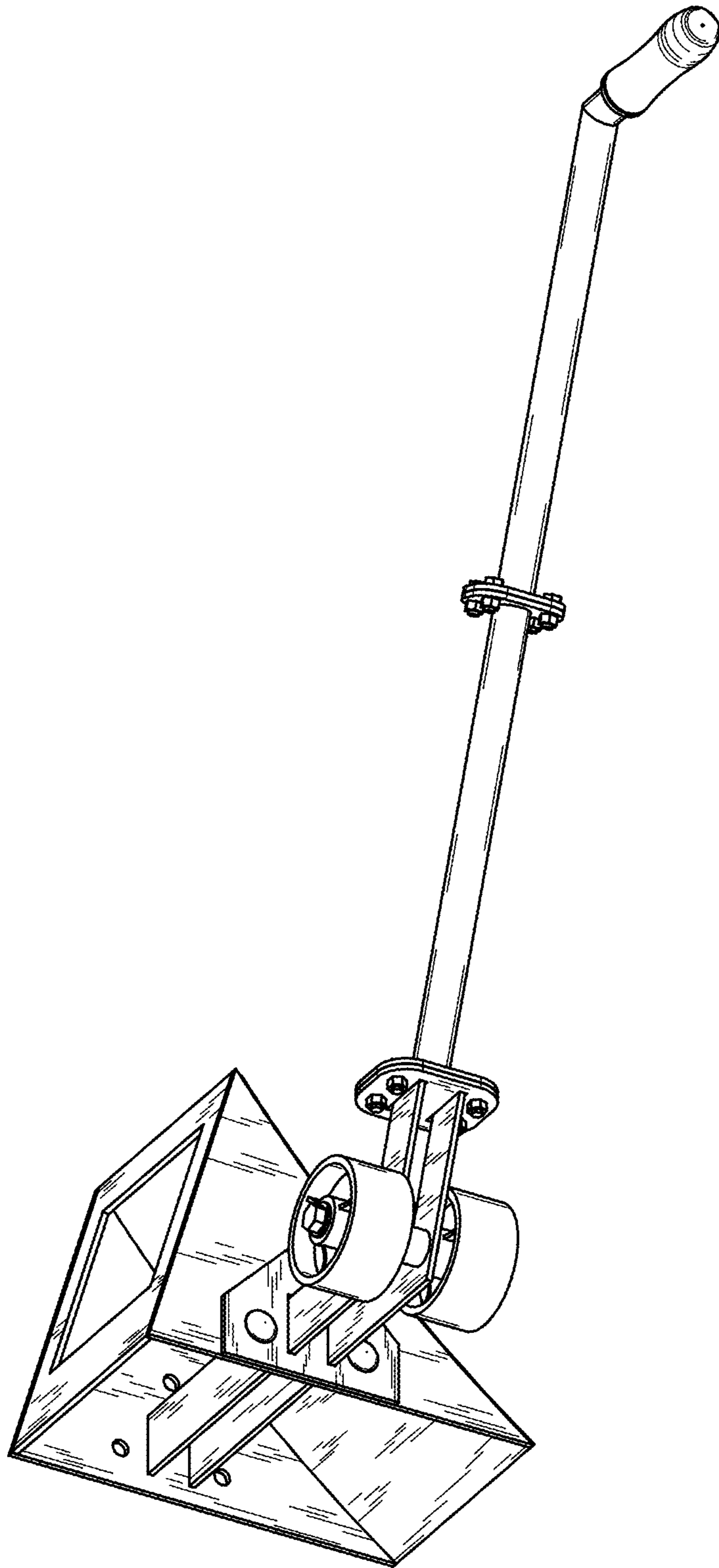

Fig. 4

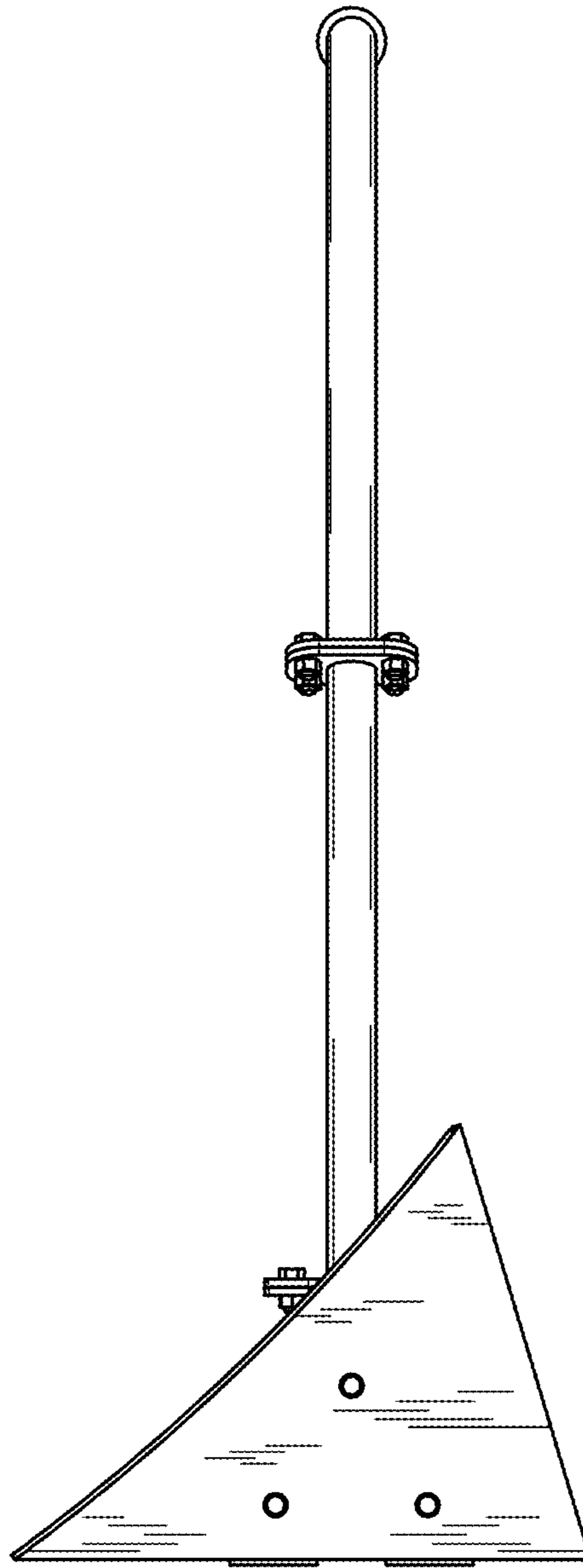

Fig. 5

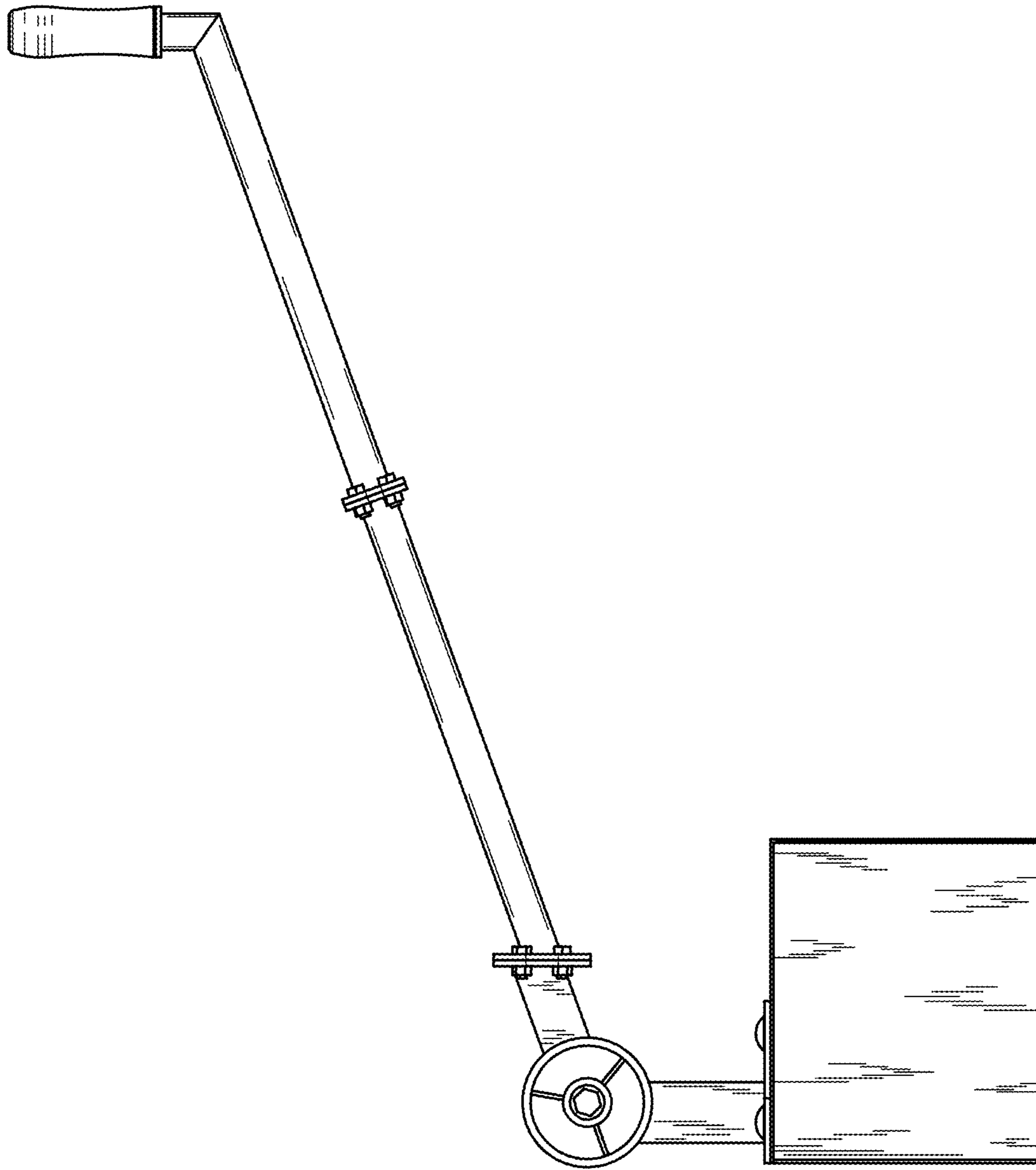

Fig. 6

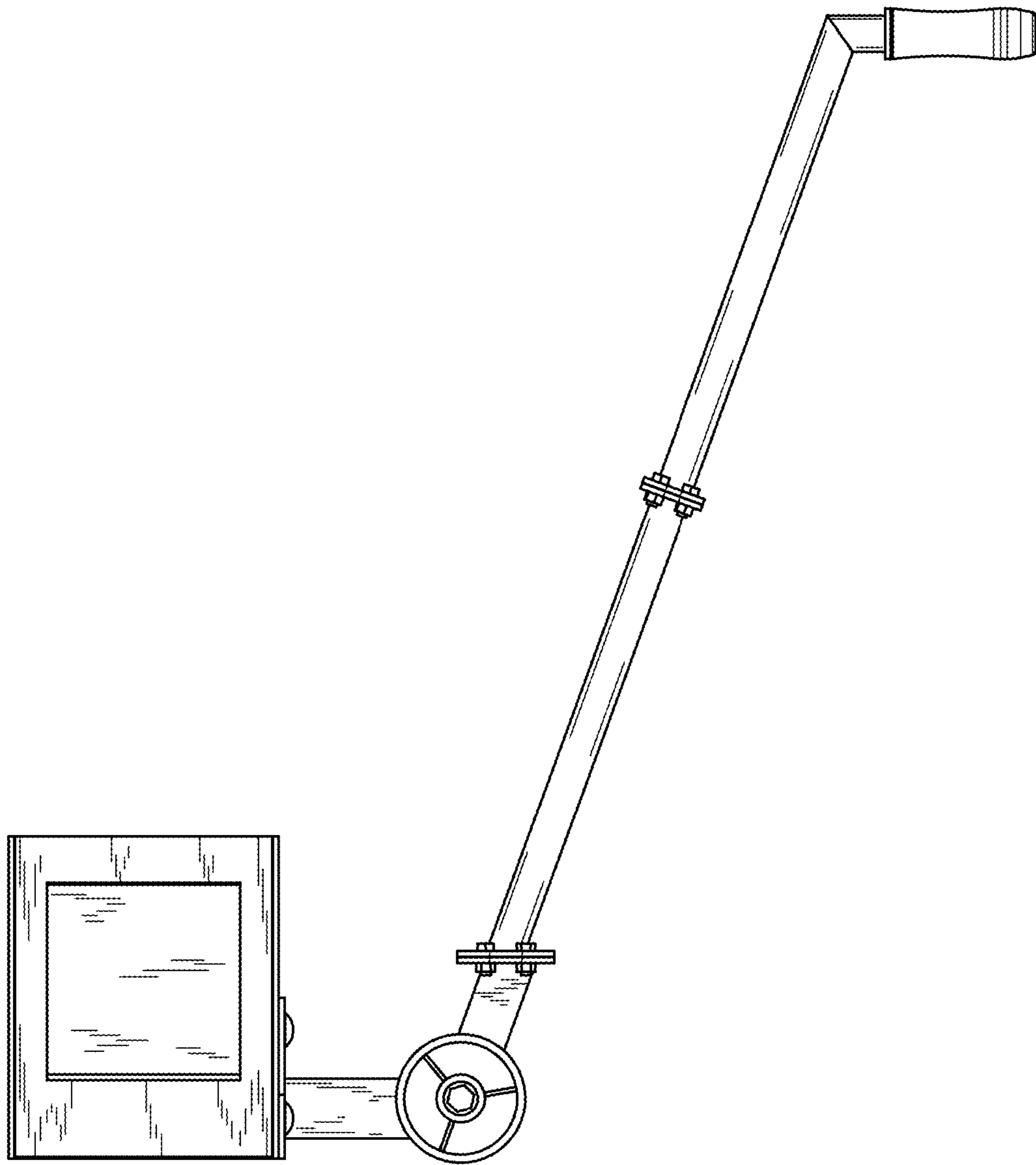

Fig. 7

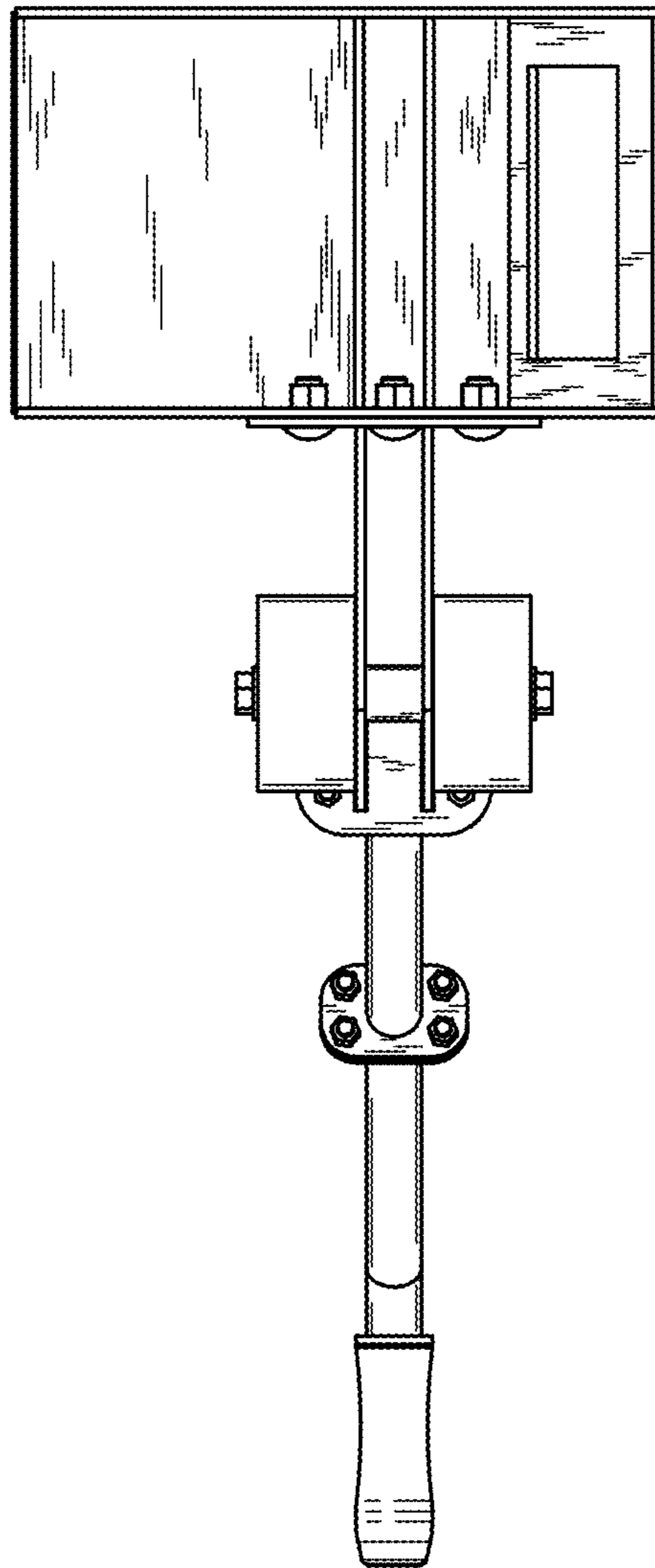

Fig. 8

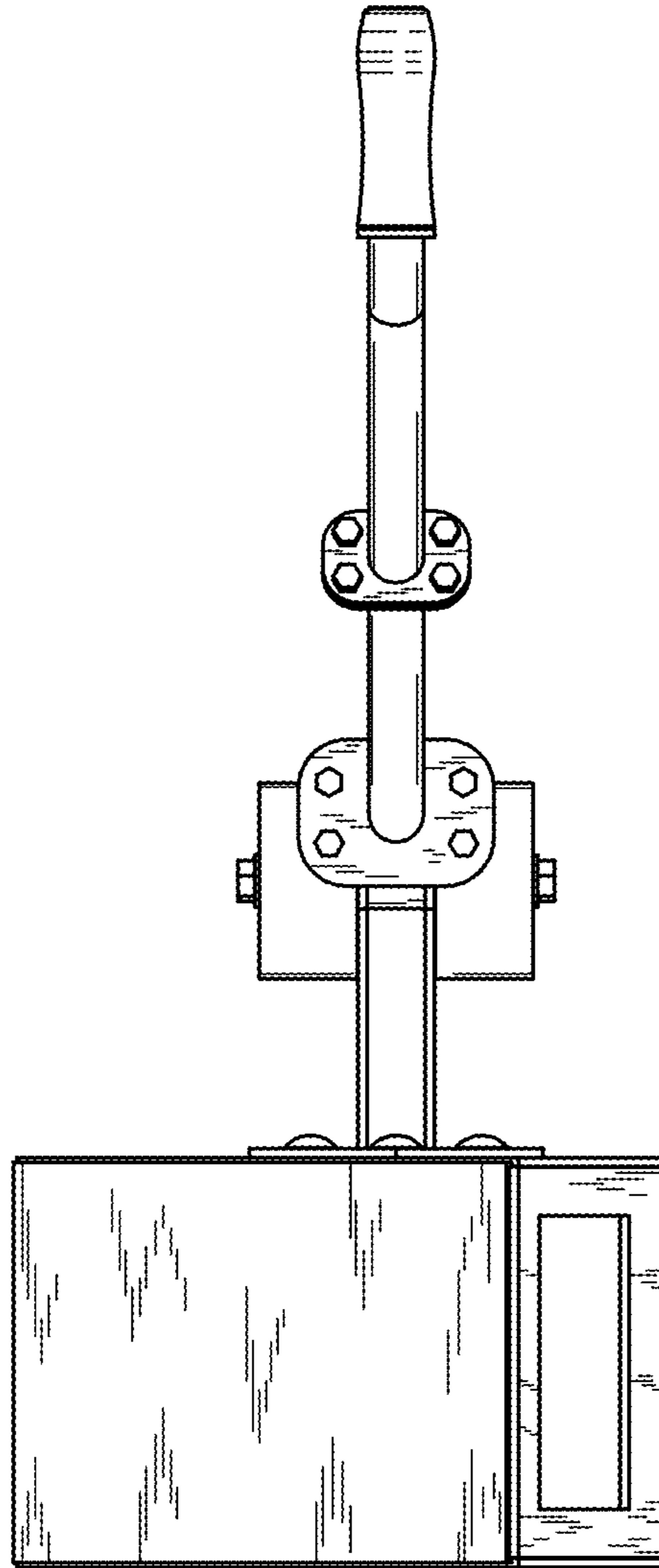

Fig. 9

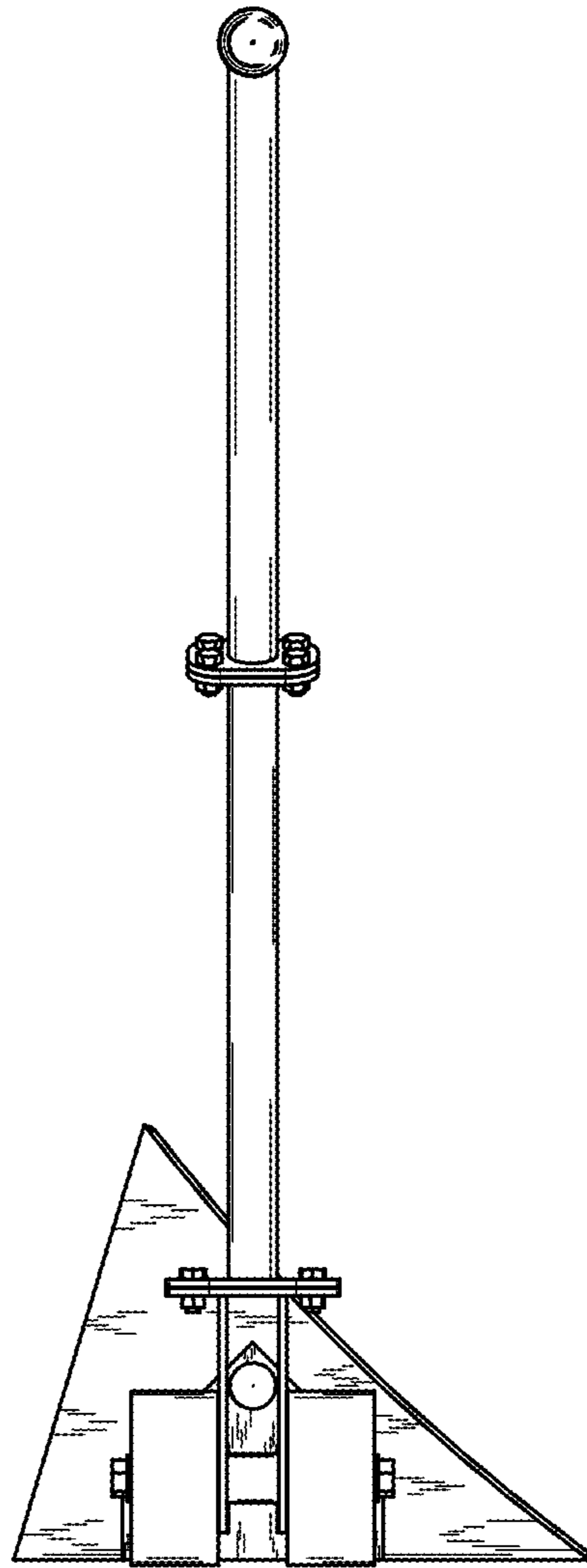

Fig. 10